



LANGDREHTECHNIK

TECHNOLOGY FOR SWISS
TYPE MACHINES

2024/2025



ERLEBEN SIE HORN
EXPLORE HORN

Der neue Katalog Langdrehtechnik von HORN – Abgestimmt auf Ihre Bedürfnisse

In diesem Katalog finden Sie eine Auswahl an HORN-Produkten, die speziell für den Einsatz auf Langdrehmaschinen abgestimmt sind.

Zu den folgenden Themen haben wir die passenden Werkzeuge für Ihren Anwendungsfall zusammengestellt:

- Innenbearbeitung
- Ein- und Abstechen
- Außenbearbeitung
- Gewindedrehen
- Gewindewirbeln
- Lineareinheiten

Bei der Wahl der individuellen Schnittparameter unterstützen Sie unsere Tabellen mit praxiserprobten Erfahrungswerten. Nutzen Sie das Fachwissen unserer Innen- und Außendienstmitarbeiter. Denn wir kennen den Markt und haben für Ihre Aufgaben und Herausforderungen die passenden Lösungen.



Markus Horn
Geschäftsführer
Paul Horn GmbH



Matthias Rommel
Geschäftsführer
Paul Horn GmbH

The new catalogue Technology for Swiss Type Machines from HORN - Designed for your application

In this catalogue you will find a selection of HORN products which are specially designed for use on Swiss Type Machines.

For the following issues we have selected the right tools for your application:

- Internal Machining
- Grooving and Parting Off
- External Machining
- Threading
- Thread Whirling
- Linear Units

To assist you when choosing cutting parameters, our tables provide proven empirical values. Take advantage of the expertise of our office staff and sales engineers, because we know the market well and have the right solutions for your applications and challenges.



Markus Horn
CEO
Paul Horn GmbH



Matthias Rommel
CEO
Paul Horn GmbH

Inhaltsverzeichnis / Index

A	System Supermini	A
B	System Supermini Hochhart Schneidstoffe System Supermini Ultra-Hard Cutting Materials	B
C	System Mini	C
D	System Mini Hochharte Schneidstoffe System Mini Ultra-Hard Cutting Materials	D
E	Technische Hinweise Supermini / Mini Technical Instructions	E
F	System 100/101	F
G	System 224	G
H	System 262	H
I	System 264	I
J	System 274	J
K	System 312	K
L	System S32T	L
M	System S34T	M



- N Technische Hinweise Stechdrehen**
Technical Instructions Grooving
- O Gewindedrehen**
Threading
- P Graf Schnellwechselsystem**
Graf Quick Change System
- Q W+F Lineareinheit für Langdreher**
W+F Linear Unit for Swiss Type Machines
- R Gewindewirbeln**
Thread Whirling
- S Zubehör**
Additional Equipment

N



O

P

Q

R

S



System	105	109	106	107	108	111	114
Innenbearbeitung / Internal Grooving							
Bohrungs-Ø Bore Ø	0,2-6,8	≥ 6,0	≥ 6,0	≥ 7,0	≥ 8,0	≥ 10,0	≥ 13,8 (≥ 16,5)
Stechbreite Width of groove	0,5-2,0	1,0-2,0	0,7-1,5	1,0-2,0	0,7-2,0	0,7-3,0	0,7-3,0
Stechtiefe Depth of groove	2,5	2,5	0,8	2,0	1,0	2,3	4,0 (6,5)
Einstechen und Ausdrehen Grooving and Boring	•	•	•	•	•	•	•
Gewindedrehen Threading	•			•	•	•	•
Fasen Chamfering	•	•	•	•	•	•	•
Axialeinstechen Facegrooving	•	•					•
Feinstbearbeitung Ultrafine machining							
Außenbearbeitung / External Grooving							
Stechbreite Width of groove							
Stechtiefe Depth of groove							
Einstechen Grooving							
Längsdrehen Turning							
Abstechen Parting off							
0 Gewinde Thread							
für kurvengesteuerte Maschine for cam-controlled machines							
µ-Finish							
Kapitel Chapter	A	A	B	B	B	B	B

System	100/ 101	224	262	264	274	312	32T	34T
Innenbearbeitung / Internal Grooving								
Bohrungs-Ø Bore Ø								
Stechbreite Width of groove								
Stechtiefe Depth of groove								
Einstechen und Ausdrehen Grooving and Boring								
Gewindedrehen Threading								
Fasen Chamfering								
Axialeinstechen Facegrooving								
Feinstbearbeitung Ultrafine machining								
Außenbearbeitung / External Grooving								
Stechbreite Width of groove	2,0-3,0/ 1,2-1,6	1,2-1,6	0,5-2,0	1,5-3,0	0,5-7	0,5-6,3	2,0-3,0	1,03-5,0
Stechtiefe Depth of groove	≤ 21 / ≤ 13	≤ 13	≤ 5	≤ 16	≤ 6	≤ 8	≤ 3,5	≤ 6,5
Einstechen Grooving	• / •	•	•	•	•	•	•	•
Längsdrehen Turning	• / -		•	•	•	•	•	•
Abstechen Parting off	• / •	•	•	•	•	•	•	•
0 Gewinde Thread				•	•		•	
für kurvengesteuerte Maschine for cam-controlled machines			•					
µ-Finish					•			
Kapitel Chapter	F	G	H	I	J	K	L	M

Übersicht Anwendungen Drehen

Overview Application Turning

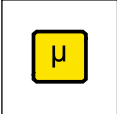
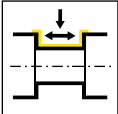
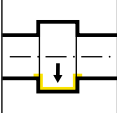
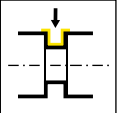
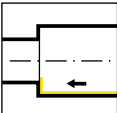
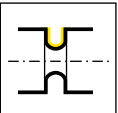
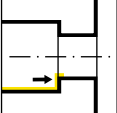

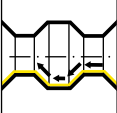
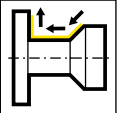
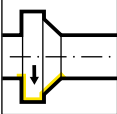
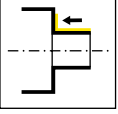
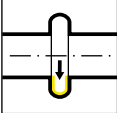
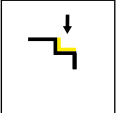
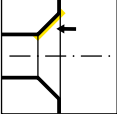
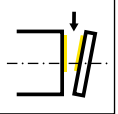
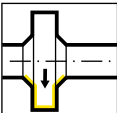
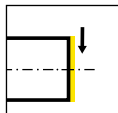
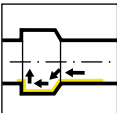
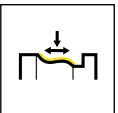
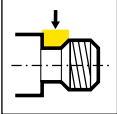
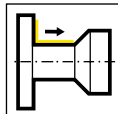
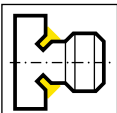
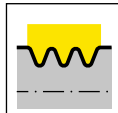





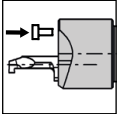
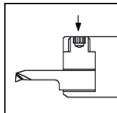
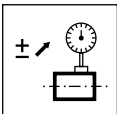

	µ Finish		Einstechen Längsdrehen Grooving and side turning
	Einstechen innen Internal grooving		Einstechen außen Grooving external
	Bohrung Ausdrehen innen Internal boring		Einstechen Vollradius außen External grooving full radius
	Rückwärtsdrehen innen Internal back turning		Einstechen mit NAKF External grooving with NAKF
	Ausdrehen und Fasen innen Internal profiling and chamfering		Kopierdrehen außen External profiling
	Vorstechen und Fasen innen Internal pre-grooving and chamfering		Längsdrehen außen External side turning
	Einstechen Vollradius innen Internal grooving full radius		Teilschnitt Partial cut
	Fasen innen Internal chamfering		Abstechen Parting off
	Einstechen mit Fase innen Internal grooving with chamfer		Plandrehen Face turning
	Bohrung Kontur Ausdrehen Boring and profiling		Kopierdrehen Profiling
	Gewindefreistich Corner thread relief		Rückwärtsdrehen außen External back turning
	Eckenfreistich außen External corner relief		Poly-V-Riemennut Poly-V-belt grooves

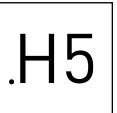
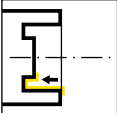
Übersicht Anwendungen Drehen

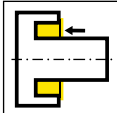
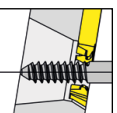
Overview Application Turning

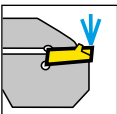

	Feinstbearbeitung Ultrafine machining		Stirnspannelement Face clamping
	Feindrehen Fine turning		Abhebeelement Lift element
	Geometrieformen Kind of geometry		Einrichten Setup
	Seegerringnuten Circlip grooves		Spanleitstufe neutral 0° Spanwinkel Chipbreaker neutral 0° Chip angle
	Axialstechen Face grooving		Spanleitstufe positiv neutral 5° Spanwinkel Chipbreaker positive-neutral 5° Chip angle
	Axialstechen vor der Mitte innen Internal face grooving in front of center		HORN 3-D Geometrie Bohrungsbearbeitung HORN 3D Chip breaker Machining of bores
	Axialstechen mit Bund Face grooving with collar		Gewindewirbeln Thread whirling
	Innenkühlung Internal coolant		
	Zielgerichtete Kühlung Targeted coolant		
	Kühlung durch die Schneidplatte Coolant through insert		
	Werkstoffgruppen Diamant Material group Diamond		

Übersicht Anwendungen Gewinde

Overview Application Thread



Gewinde Teilprofil
Partial profile thread



Gewinde Vollprofil
Full profile thread

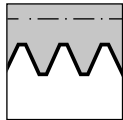

Gewinde außen
External thread

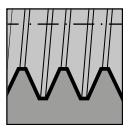

Gewinde innen
Internal thread



Whitworth-Rohrgewinde BSW/BSF
Whitworth pipe thread BSW/BSF



Unified-Gewinde
Unified thread

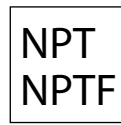

NPT
NPTF
NPT-Rohrgewinde
National pipe thread



PG
Panzerrohrgehwinde
Steel conduit thread

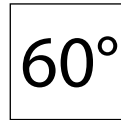

60°
Metrisches ISO-Gewinde
Metric ISO thread

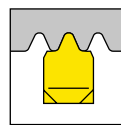

Whitworth-Rohrgewinde
Whitworth pipe thread

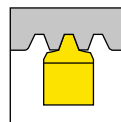

Trapezgewinde
Trapezoidal thread



.GM
Geometrie GM - Gewindedrehen
Geometry GM - Threading

Keine Unterlegplatte erforderlich. Sämtliche HORN-Gewindeprofile sind mit einem **KEGELMANTEL-FREISCHLIFF** versehen.

No shims necessary. All HORN thread profiles are manufactured with full ground radial clearance.

- Alle Abmessungen sind in mm angegeben, sofern nicht anders vermerkt.
All dimensions in mm, unless otherwise noted
- Weitere Abmessungen und Ausführungen sind auf Anfrage erhältlich.
Further dimensions and versions are available on request.
- Das Anzugsmoment der Schrauben finden Sie im Kapitel "Technische Hinweise".
For torque specification of the screw, please see "Technical Instructions".
- Lieferzeiten / delivery times
 - ▲ ab Lager / on stock
 - △ 4 Wochen / 4 weeks
- Einsatz für Werkstoffgruppen / Use for material groups
 - empfohlen / recommended
 - bedingt einsetzbar / alternative recommended
 - nicht geeignet / not suitable

Die HORN-Trennstellencodierung - wofür wird sie benötigt?

Die Trennstellencodierung stellt sicher, dass Sie immer die zueinander passenden Werkzeuge finden und wird bei Werkzeughaltern und bei Schneidplatten ausgewiesen. Wenn die Codes übereinstimmen, kann die Schneidplatte im entsprechenden Werkzeughalter verwendet werden.

Das gilt auch für unser modulares Haltersystem, hier gibt die Trennstellencodierung die Schnittstelle zwischen Grundhalter und Kassette an.

The HORN connection interface code - what is it needed for?

The connection interface code ensures that you will always find the appropriate tools and is shown on toolholders and inserts. If the codes match, the insert can be used in the corresponding toolholder.

This also applies to our modular holder system, where the connection code indicates the interface between the holder and the cassette.

HORN-Trennstellencodes und mögliche Kombinationen:

HORN connection interface codes and possible combinations:

HIS = Plattensitzgröße / Insert seat

HWS = Trennstelle Werkstückseitig / Interface workpiece side

HMS = Trennstelle Maschinenseitig / Interface machine side

HIS	↔	HWS
HMS	↔	HWS

Beispiel Schneidplatte

Example insert

Bestellnummer Part number	w	r	h_1	HIS		MG12	H54	T125	TN35
S223.0200.32	2	0,2	3,65	22301		▲	▲	▲	▲

Beispiel Klemmhalter

Example toolholder

Bestellnummer Part number	h	b	l_1	l_2	h_1	b_1	f_1	f	t_{max}	D_{max}	HWS
RH223.1010.01	10	10	80	20	12	12	9,2	$f_{1+w/2}$	8	25	12301 • 22301



Supermini



**Klemmhalter und
Schneidplatten**

**Toolholder and
Inserts**

Geometrien und
Vorschübe
Geometries and feed rates

Seite/Page
19

Klemmhalter
Toolholder
B105/BU105/H105/
HC105/962/963/AIH/
HF.N/VDI/B105C/
B105TS/WFB.105/
B109

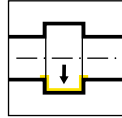

Seite/Page
20-22, 30-36,
39-46, 70-77,
79, 145-146,
155-156

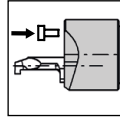

Seite/Page
24-27

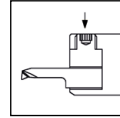

Seite/Page
29

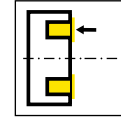

Seite/Page
150, 172

Übersicht Elemente
Overview Elements

Seite/Page
23, 28

Grundhalter Graf
Basic toolholder Graf
IR105/G

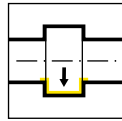

Seite/Page
37

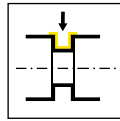

Seite/Page
57

Einbauhalter Graf
Cartridge Graf
IR105

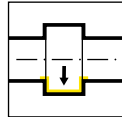

Seite/Page
38

Grundhalter
Basic toolholder
HC105/L760/BGT

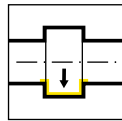

Seite/Page
47, 50-51, 53-54

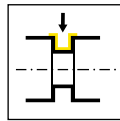

Seite/Page
48

Kassette
Cassette
KC760

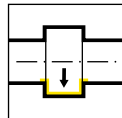

Seite/Page
49

Einstellbare Halter
Adjustable holder
BKT/N

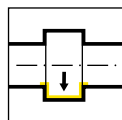

Seite/Page
52, 55-56, 60-66

Zwischenstück Graf
Adaptor Graf
Z/N



Seite/Page
58-59

Ersatzteile und Zubehör
Spare Parts and Additional
Equipment

Seite/Page
67

Technische Hinweise
Technical Instructions

Seite/Page
68

Höheneinstell-
vorrichtung
Device for height adjusting
HVR.40

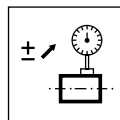

Seite/Page
69

Bohrstangen-Aufnahme
Adaptor for boring bars
001C

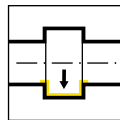

Seite/Page
78

Schneidplatte
Insert
105/A105/109/A109

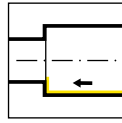

Seite/Page
80, 82, 84, 86-87,
89, 91, 98-101,
109-110, 144,
147, 157-158



Seite/Page
81, 83, 85, 88,
90, 102-104

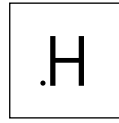

Seite/Page
92-93



Seite/Page
94-97, 159-160

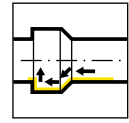

Seite/Page
105-108

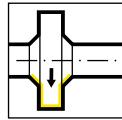

Seite/Page
111, 161

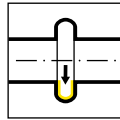

Seite/Page
112-114, 166

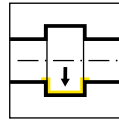

Seite/Page
115-123,
162-165

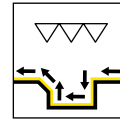

Seite/Page
124

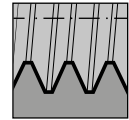

Seite/Page
125-134,
168-169

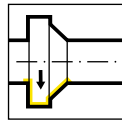

Seite/Page
135

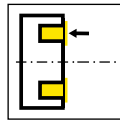

Seite/Page
136-141,
151-152, 173

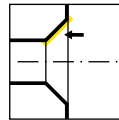

Seite/Page
142

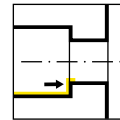

Seite/Page
143, 167

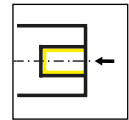

Seite/Page
153-154

Platte
Insert
105/109

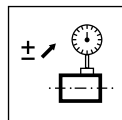

Seite/Page
148-149,
170-171

Geometrien und Vorschübe - Supermini

Geometries and feed rates - Supermini



A

Geometrie Geometry	Werkstoff Material	Vorschubbereich f [mm/U] Feed rate f [mm/rev]	Bearbeitung Machining						
	<table border="1"> <tr> <td>P</td> <td>M</td> <td>K</td> </tr> <tr> <td>N</td> <td>S</td> <td>H</td> </tr> </table>	P	M	K	N	S	H	<p>← $f = 0,04-0,06$</p> <p>$a_p = 0,15-0,5$ mm</p>	
P	M	K							
N	S	H							
	<table border="1"> <tr> <td>P</td> <td>M</td> <td>K</td> </tr> <tr> <td>N</td> <td>S</td> <td>H</td> </tr> </table>	P	M	K	N	S	H	<p>← $f = 0,05-0,1$</p> <p>$a_p = 0,15-0,5$ mm</p>	
P	M	K							
N	S	H							
	<table border="1"> <tr> <td>P</td> <td>M</td> <td>K</td> </tr> <tr> <td>N</td> <td>S</td> <td>H</td> </tr> </table>	P	M	K	N	S	H	<p>↓ $f = 0,01-0,04$</p> <p>↔ $a_p = 0,03-0,05$ mm</p>	
P	M	K							
N	S	H							
	<table border="1"> <tr> <td>P</td> <td>M</td> <td>K</td> </tr> <tr> <td>N</td> <td>S</td> <td>H</td> </tr> </table>	P	M	K	N	S	H	<p>← $f = 0,005-0,015$</p> <p>$a_p = 0,01-0,05$ mm</p>	
P	M	K							
N	S	H							
	<table border="1"> <tr> <td>P</td> <td>M</td> <td>K</td> </tr> <tr> <td>N</td> <td>S</td> <td>H</td> </tr> </table>	P	M	K	N	S	H	<p>← $f = 0,003-0,04$</p> <p>$a_p = 0,005-0,1$ mm</p>	
P	M	K							
N	S	H							

Vorschubbereich f [mm/U]

Feed rate f [mm/rev]

$f = 0,01-0,03$



Einstechen
Grooving

$f = 0,02-0,05$
 $a_p = 0,15-0,5$ mm

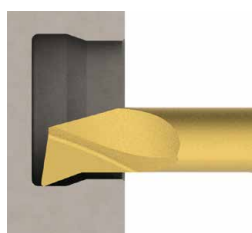

Längsdrehen
Side Turning

$f = 0,02-0,05$



Axialeinstechen
Face Grooving



Abbildung = rechtsschneidend
Picture = right hand cutting version

Bestellnummer Part number	d	l ₁	h	l ₄	HWS
B105.0010.01	10	75	9	50	105123 • 105124 • 105125
B105.0012.01	12	75	11	50	105123 • 105124 • 105125
B105.0016.01	16	75	14	50	105123 • 105124 • 105125
B105.0020.01	20	90	18	55	105123 • 105124 • 105125
B105.0022.01	22	90	20	55	105123 • 105124 • 105125
B105.0025.01	25	100	23	55	105123 • 105124 • 105125
B105.0028.01	28	120	26	72	105123 • 105124 • 105125

Ersatzteile

Spare Parts

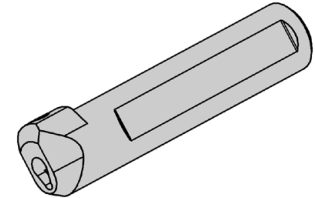
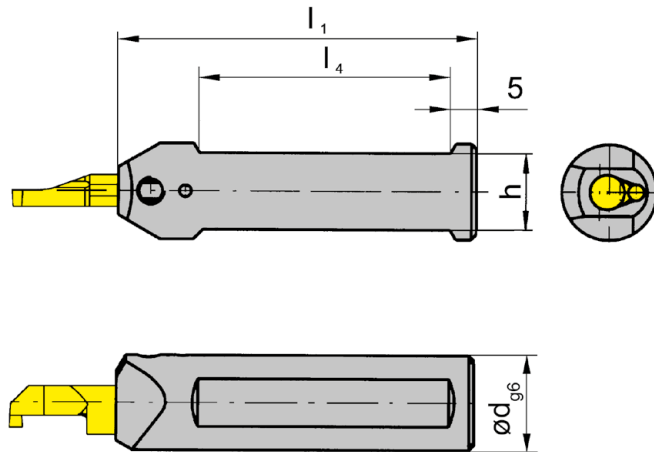
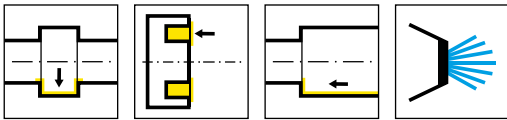
Klemmhalter Toolholder	Spannschraube Clamping Screw	TORX PLUS®-Schlüssel TORX PLUS® Wrench
B105...	6.075T15P	T15PQ



Abbildung = rechtsschneidend
Picture = right hand cutting version

Bestellnummer Part number	d	l ₁	l ₃	HWS
B105.0010.01A	10	75	57	105123 • 105124 • 105125
B105.0012.01A	12	75	63	105123 • 105124 • 105125
B105.0016.01A	16	75	63	105123 • 105124 • 105125

Ersatzteile
Spare Parts

Klemmhalter Toolholder	Spannschraube Clamping Screw	TORX PLUS®-Schlüssel TORX PLUS® Wrench
B105...	6.075T15P	T15PQ

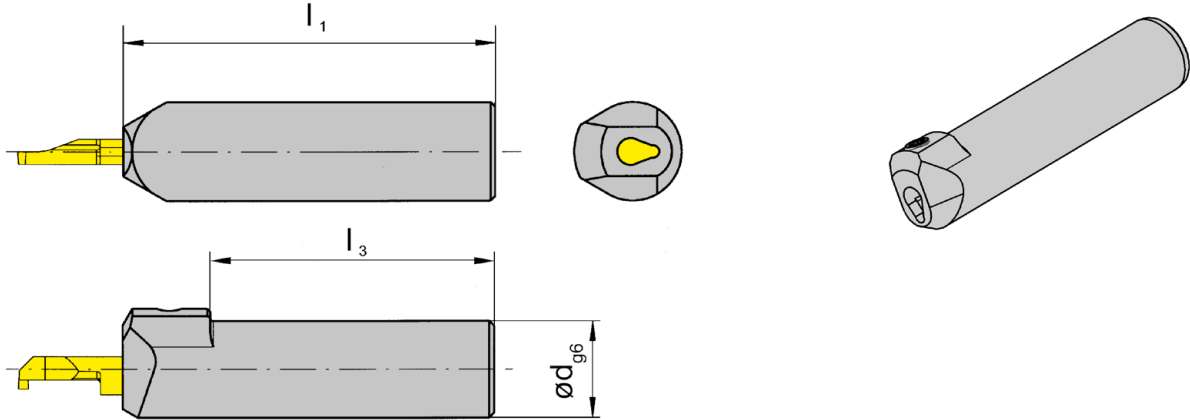
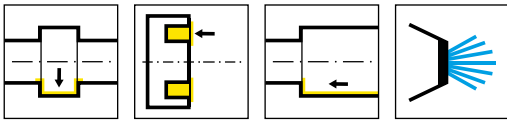

Abbildung = rechtsschneidend
Picture = right hand cutting version

Bestellnummer Part number	d	l ₁	h	l ₄	l ₅	HWS
BU105.0750.5.01	3/4"	90	17,04	70	5	105123 • 105124 • 105125
BU105.0750.5.3.01	3/4"	152,5	17,05	70	5	105123 • 105124 • 105125
BU105.1000.5.01	1"	90	23,4	65	5	105123 • 105124 • 105125
BU105.1000.5.3.01	1"	152,5	23,4	70	5	105123 • 105124 • 105125

Abmessungen in inch und mm
Dimensions in inch and mm

Kühlmittelanschluss M12x1,5 für Traub Maschinen
Der Kühlmittelanschluss gehört nicht zum Lieferumfang.
Adapter of cooling M12x1,5 for Traub machines
Coolant supply is not included.

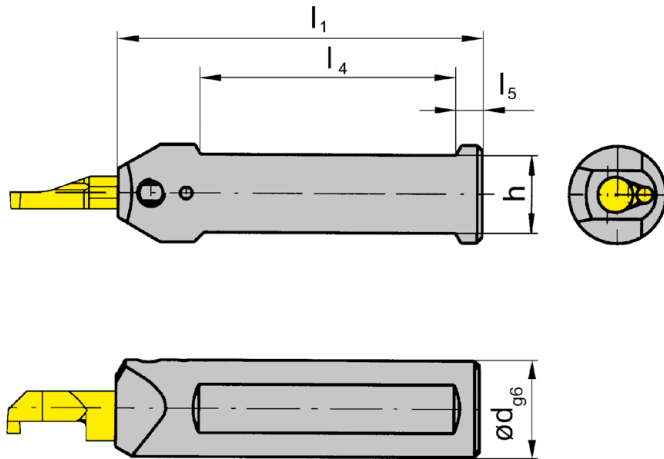
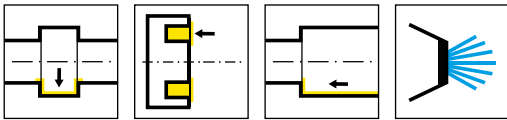
Ersatzteile

Spare Parts

Klemmhalter Toolholder	Spannschraube Clamping Screw	TORX PLUS®-Schlüssel TORX PLUS® Wrench
BU105...	6.075T15P	T15PQ

Übersicht Stirnspannelement

Overview Face clamping element



Größe 3 (HWS = 105123)
Size 3

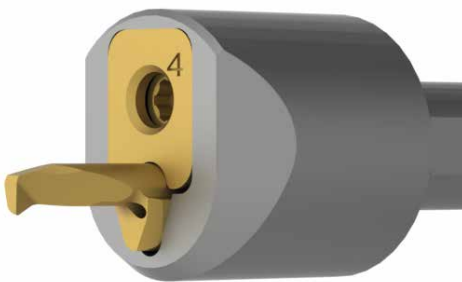
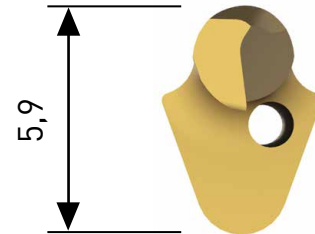

Größe 4 (HWS = 105124)
Size 4

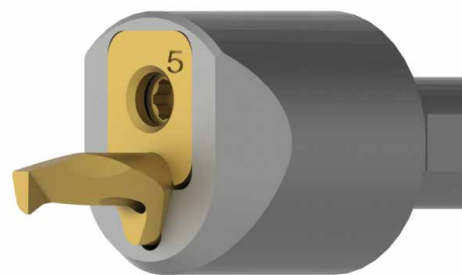
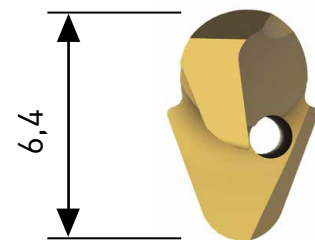

Größe 5 (HWS = 105125)
Size 5

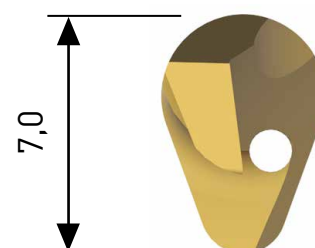



Abbildung = rechtsschneidend
Picture = right hand cutting version

Bestellnummer Part number	d	l ₁	h	l ₄	f ₁	d ₁	b	HWS
B105.0010.S.03	10	80	9	50	4,3	20	5,9	105123
B105.0012.S.03	12	80	11	50	4,3	20	5,9	105123
B105.0016.S.03	16	80	14	50	4,3	20	5,9	105123
B105.0020.S.03	20	90	18	55	4,3	20	5,9	105123
B105.0022.S.03	22	90	20	55	4,3	22	5,9	105123
B105.0025.S.03	25	100	23	55	4,3	25	5,9	105123
B105.0028.S.03	28	120	26	55	4,3	28	5,9	105123
B105.0010.S.04	10	80	9	50	4,9	20	6,4	105124
B105.0012.S.04	12	80	11	50	4,9	20	6,4	105124
B105.0016.S.04	16	80	14	50	4,9	20	6,4	105124
B105.0020.S.04	20	90	18	55	4,9	20	6,4	105124
B105.0022.S.04	22	90	20	55	4,9	22	6,4	105124
B105.0025.S.04	25	100	23	55	4,9	25	6,4	105124
B105.0028.S.04	28	120	26	55	4,9	28	6,4	105124
B105.0010.S.05	10	80	9	50	6,3	20	7	105125
B105.0012.S.05	12	80	11	50	6,3	20	7	105125
B105.0016.S.05	16	80	14	50	6,3	20	7	105125
B105.0020.S.05	20	90	18	55	6,3	20	7	105125
B105.0022.S.05	22	90	20	55	6,3	22	7	105125
B105.0025.S.05	25	100	23	55	6,3	25	7	105125
B105.0028.S.05	28	120	26	55	6,3	28	7	105125

Ersatzteile

Spare Parts

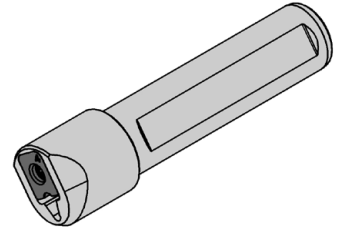
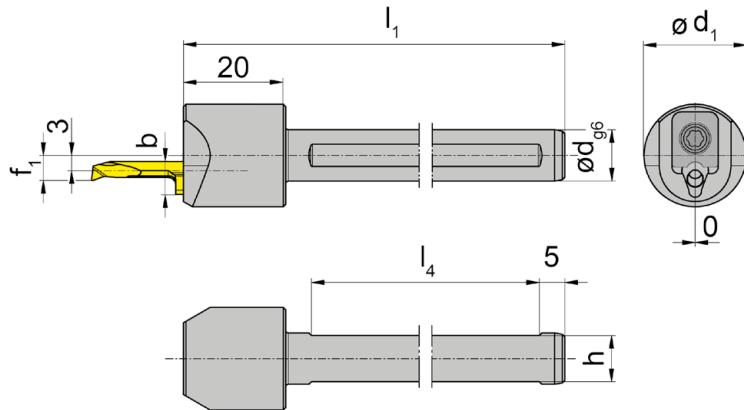
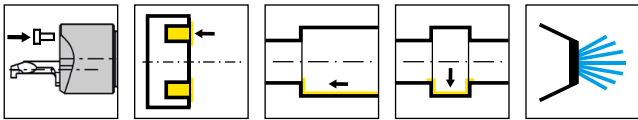
Klemmhalter Toolholder	Spannelement Clamping element	TORX PLUS®-Schlüssel TORX PLUS® Wrench
B105.0...03	010.0105.03	T15PL
B105.0...04	010.0105.04	T15PL
B105.0...05	010.0105.05	T15PL



Abbildung = rechtsschneidend
Picture = right hand cutting version

Bestellnummer Part number	d	l ₁	h	l ₄	f ₁	d ₁	b	HWS
BU105.0500.S.03	1/2"	80	10,7	50	4,3	20	5,9	105123
BU105.0625.S.03	5/8"	80	13,87	50	4,3	20	5,9	105123
BU105.0750.S.03	3/4"	90	17,05	55	4,3	19,05	5,9	105123
BU105.1000.S.03	1"	90	23,4	55	4,3	25,4	5,9	105123
BU105.0500.S.04	1/2"	80	10,7	50	4,9	20	6,4	105124
BU105.0625.S.04	5/8"	80	13,87	50	4,9	20	6,4	105124
BU105.0750.S.04	3/4"	90	17,05	55	4,9	19,05	6,4	105124
BU105.1000.S.04	1"	90	23,4	55	4,9	25,4	6,4	105124
BU105.0500.S.05	1/2"	80	10,7	50	6,3	20	7	105125
BU105.0625.S.05	5/8"	80	13,87	50	6,3	20	7	105125
BU105.0750.S.05	3/4"	90	17,05	55	6,3	19,05	7	105125
BU105.1000.S.05	1"	90	23,4	55	6,3	25,4	7	105125

Abmessungen in inch und mm
Dimensions in inch and mm

Ersatzteile

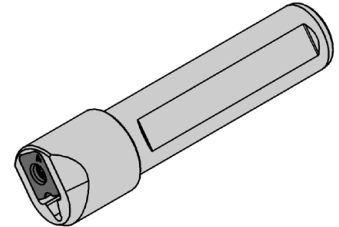
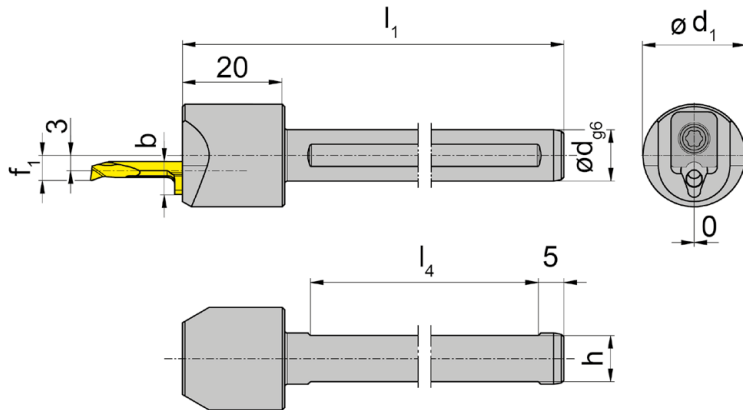
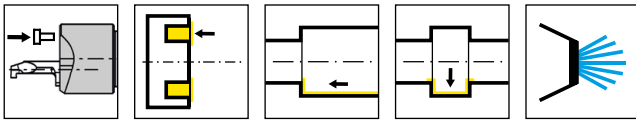
Spare Parts

Klemmhalter Toolholder	Spannelement Clamping element	TORX PLUS®-Schlüssel TORX PLUS® Wrench
BU105.0...03	010.0105.03	T15PL
BU105.0...04	010.0105.04	T15PL
BU105.0...05	010.0105.05	T15PL

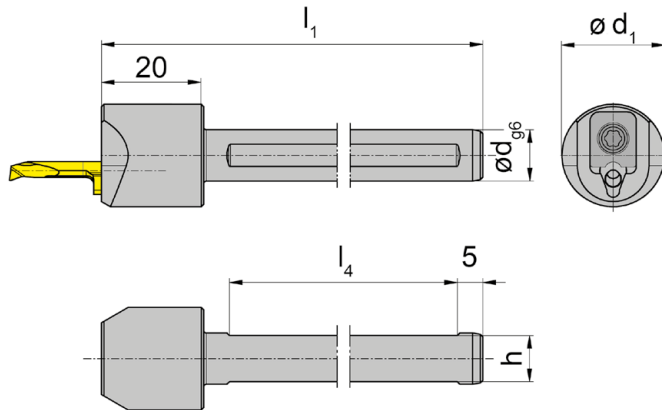
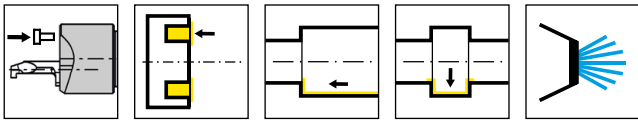

Bestellnummer Part number	d	h	l ₁	l ₄	d ₁	HWS
B105.0010.S.SET	10	9	80	50	20	105123 • 105124 • 105125
B105.0012.S.SET	12	11	80	50	20	105123 • 105124 • 105125
B105.0016.S.SET	16	14	80	50	20	105123 • 105124 • 105125
B105.0020.S.SET	20	18	90	55	20	105123 • 105124 • 105125
B105.0022.S.SET	22	20	90	55	22	105123 • 105124 • 105125
B105.0025.S.SET	25	23	100	55	25	105123 • 105124 • 105125
B105.0028.S.SET	28	26	120	55	28	105123 • 105124 • 105125

Hinweis:

Ein Klemmhalter-Set beinhaltet je 3 Spannelemente

Note:

One toolholder set includes 3 clamping elements each

Ersatzteile

Spare Parts

Klemmhalter Toolholder	Spannelement Clamping element	TORX PLUS®-Schlüssel TORX PLUS® Wrench
B105...	010.0105.03 010.0150.04 010.0150.05	T15PW

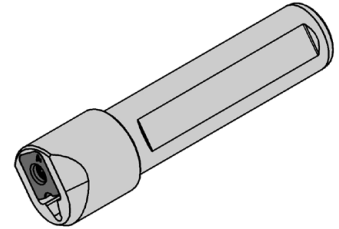
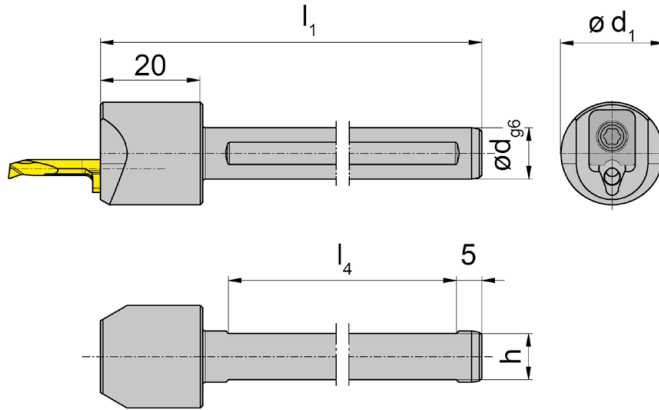
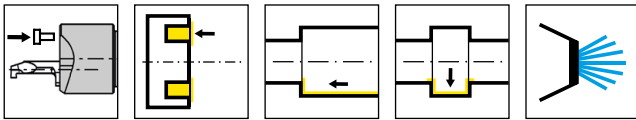

Bestellnummer Part number	d	h	l ₁	l ₄	d ₁	HWS
BU105.0500.S.SET	.500"	10,7	80	50	20	105123 • 105124 • 105125
BU105.0625.S.SET	.625"	13,875	80	50	20	105123 • 105124 • 105125
BU105.0750.S.SET	.750"	17,05	90	55	.750"	105123 • 105124 • 105125
BU105.1000.S.SET	1"	23,4	90	55	1"	105123 • 105124 • 105125

Abmessungen in inch und mm
Dimensions in inch and mm

Hinweis:

Ein Klemmhalter-Set beinhaltet je 3 Spannelemente

Note:

One toolholder set includes 3 clamping elements each

Ersatzteile

Spare Parts

Klemmhalter Toolholder	Spannelement Clamping element	TORX PLUS®-Schlüssel TORX PLUS® Wrench
BU105...	010.0105.03 010.0150.04 010.0150.05	T15PW



Größe 3 (HWS = 105123)
Size 3

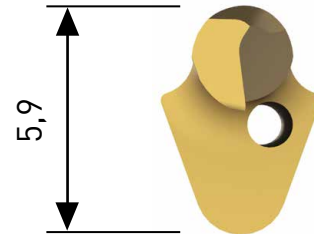

Größe 4 (HWS = 105124)
Size 4

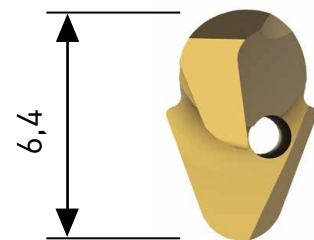

Größe 5 (HWS = 105125)
Size 5

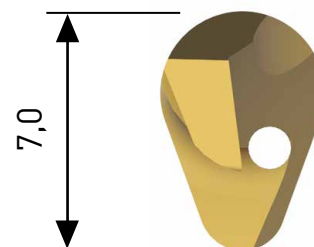

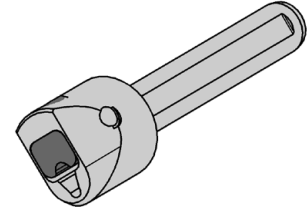
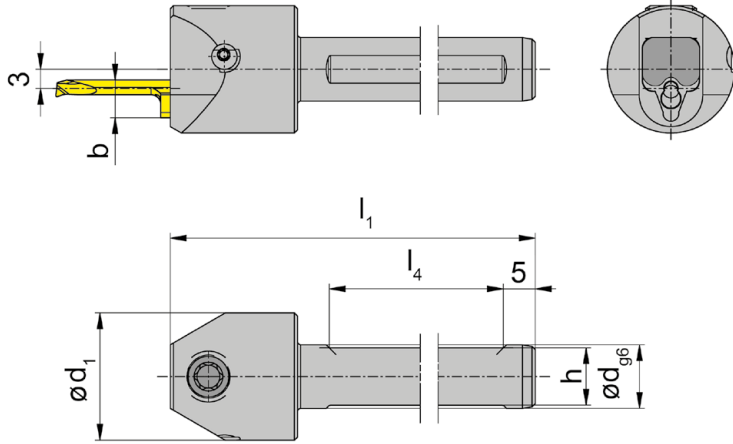
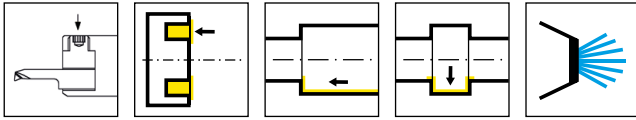

Bestellnummer Part number	d	l ₁	h	l ₄	d ₁	b	HWS
B105.0010.A.03	10	80	9	50	20	5,9	105123
B105.0012.A.03	12	80	11	50	20	5,9	105123
B105.0016.A.03	16	80	14	50	20	5,9	105123
B105.0020.A.03	20	90	18	55	20	5,9	105123
B105.0025.A.03	25	100	23	55	25	5,9	105123
B105.0010.A.04	10	80	9	50	20	6,4	105124
B105.0012.A.04	12	80	11	50	20	6,4	105124
B105.0016.A.04	16	80	14	50	20	6,4	105124
B105.0020.A.04	20	90	18	55	20	6,4	105124
B105.0025.A.04	25	100	23	55	25	6,4	105124
B105.0010.A.05	10	80	9	50	20	7	105125
B105.0012.A.05	12	80	11	50	20	7	105125
B105.0016.A.05	16	80	14	50	20	7	105125
B105.0020.A.05	20	90	18	55	20	7	105125
B105.0025.A.05	25	100	23	55	25	7	105125

b = Schneidplattenhöhe
b = Height of insert

Ersatzteile

Spare Parts

Klemmhalter Toolholder	Spannelement Clamping element	TORX PLUS®-Schlüssel TORX PLUS® Wrench
B105.0...03	010.0003.0668	T25PQ
B105.0...04	010.0004.0667	T25PQ
B105.0...05	010.0005.0663	T25PQ



Abbildung = rechtsschneidend
Picture = right hand cutting version

Bestellnummer Part number	d	l ₁	h	l ₄	l ₅	HWS
B105.0022.1.2.01	22	120	20	72	5	105123 • 105124 • 105125

Ersatzteile

Spare Parts

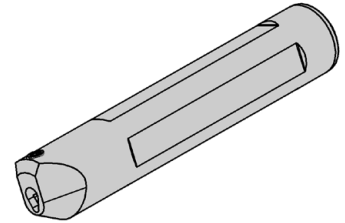
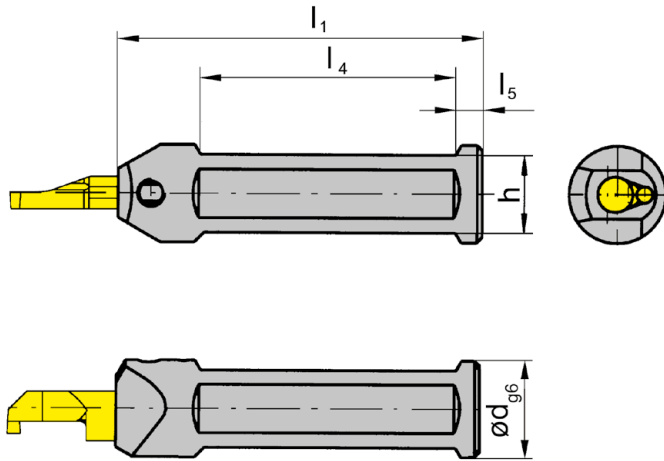
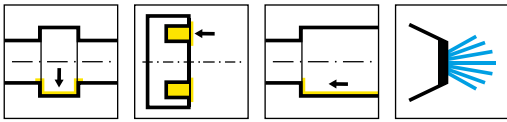
Klemmhalter Toolholder	Spannschraube Clamping Screw	TORX PLUS®-Schlüssel TORX PLUS® Wrench
B105.0022.1.2.01	6.075T15P	T15PQ



Abbildung = rechtsschneidend
Picture = right hand cutting version

Bestellnummer Part number	d	l ₁	h	l ₄	HWS
B105.0012.K.01	12	75	11	50	105123 • 105124 • 105125
B105.0016.K.01	16	75	14	50	105123 • 105124 • 105125
B105.0020.K.01	20	90	18	50	105123 • 105124 • 105125
B105.0022.K.01	22	90	20	55	105123 • 105124 • 105125
B105.0025.K.01	25	100	23	55	105123 • 105124 • 105125
B105.0012.M8.K.01	12	75	11	50	105123 • 105124 • 105125
B105.0016.M8.K.01	16	75	14	50	105123 • 105124 • 105125
B105.0020.M8.K.01	20	90	18	55	105123 • 105124 • 105125

mit zusätzlichen Spülbohrungen
with additional through coolant bores

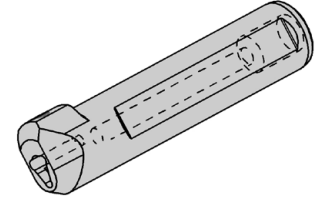
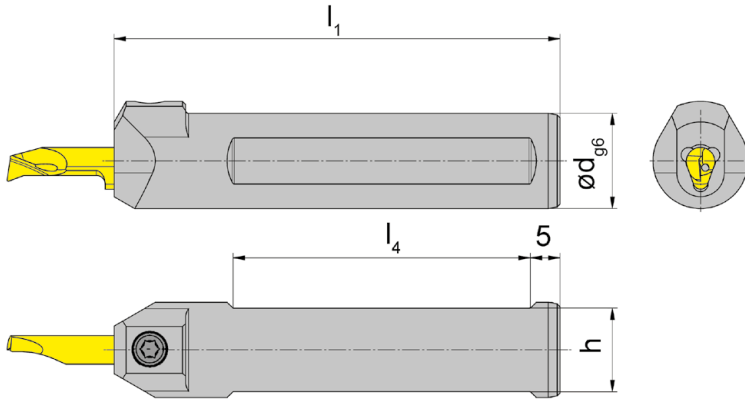
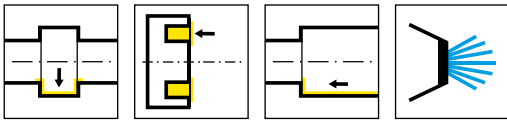
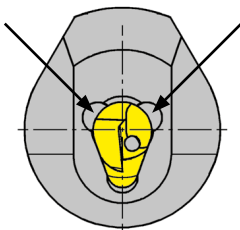

Ersatzteile
Spare Parts

Klemmhalter Toolholder	Spannschraube Clamping Screw	TORX PLUS®-Schlüssel TORX PLUS® Wrench
B105...	6.075T15P	T15PQ



Abbildung = rechtsschneidend
Picture = right hand cutting version

Bestellnummer Part number	d	l ₁	h	l ₄	HWS
B105.0012.M8.01	12	75	11	50	105123 • 105124 • 105125
B105.0016.M8.01	16	75	14	50	105123 • 105124 • 105125
B105.0020.M8.01	20	90	18	55	105123 • 105124 • 105125
B105.0025.M8.01	25	100	23	55	105123 • 105124 • 105125

Ersatzteile

Spare Parts

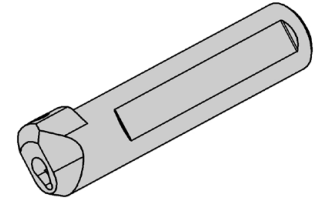
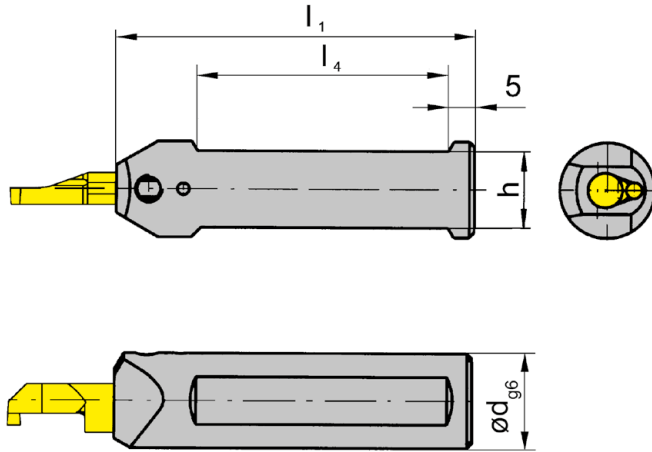
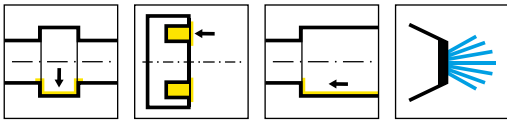
Klemmhalter Toolholder	Spannschraube Clamping Screw	TORX PLUS®-Schlüssel TORX PLUS® Wrench
B105...	6.075T15P	T15PQ



Abbildung = rechtsschneidend
Picture = right hand cutting version

Bestellnummer Part number	d	l ₁	h	b	HWS
B105.0020.1.03	20	80	18	18	105123 • 105124 • 105125 • 105225

Ersatzteile
Spare Parts

Klemmhalter Toolholder	Spannschraube Clamping Screw	TORX PLUS®-Schlüssel TORX PLUS® Wrench
B105.0020.1.03	6.075T15P	T15PQ

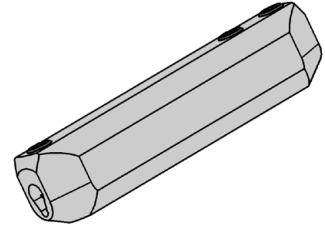
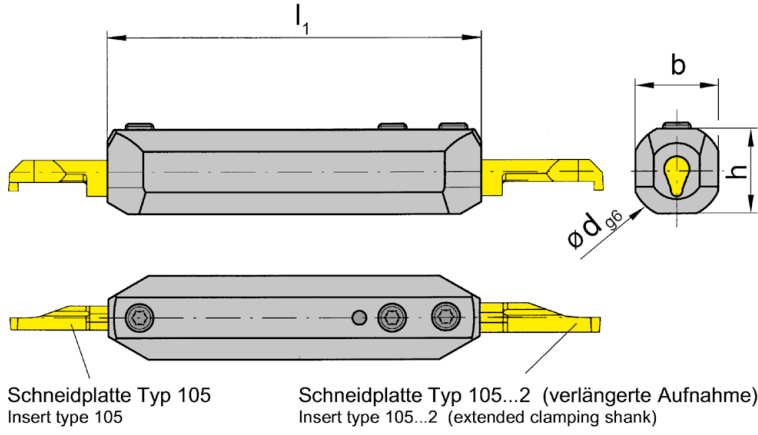
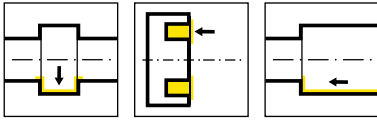

Abbildung = rechtsschneidend
Picture = right hand cutting version

Bestellnummer Part number	d	l ₁	h	b	HWS
B105.0022.2.1.01	22	80	20	20	105123 • 105124 • 105125
B105.0022.2.2.01	22	120	20	20	105123 • 105124 • 105125

Ersatzteile

Spare Parts

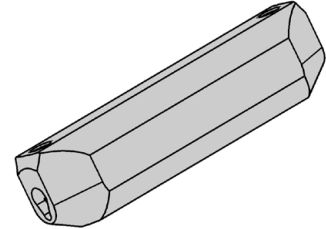
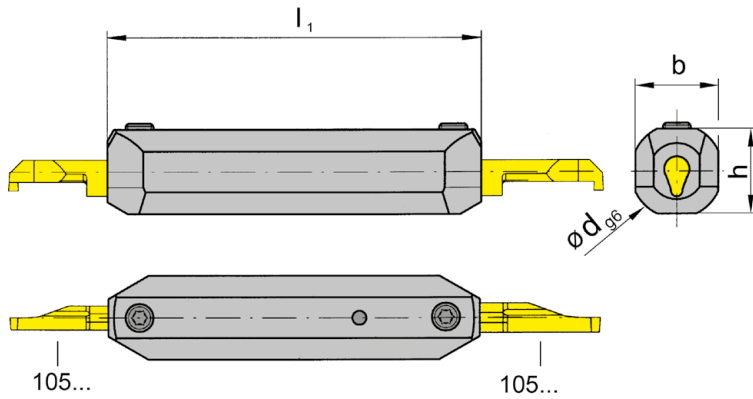
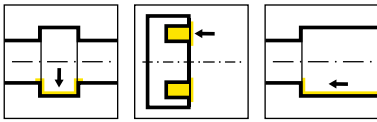
Klemmhalter Toolholder	Spannschraube Clamping Screw	TORX PLUS®-Schlüssel TORX PLUS® Wrench
B105...	6.075T15P	T15PQ



Abbildung = rechtsschneidend
Picture = right hand cutting version

Bestellnummer Part number	d	l ₁	h	l ₂	HWS
B105.0020.1.09	20	80	18	60	105123 • 105124 • 105125 • 109140

Ersatzteile
Spare Parts

Klemmhalter Toolholder	Spannschraube Clamping Screw	TORX PLUS®-Schlüssel TORX PLUS® Wrench
B105.0020.1.09	6.075T15P	T15PQ

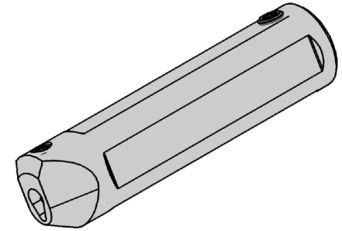
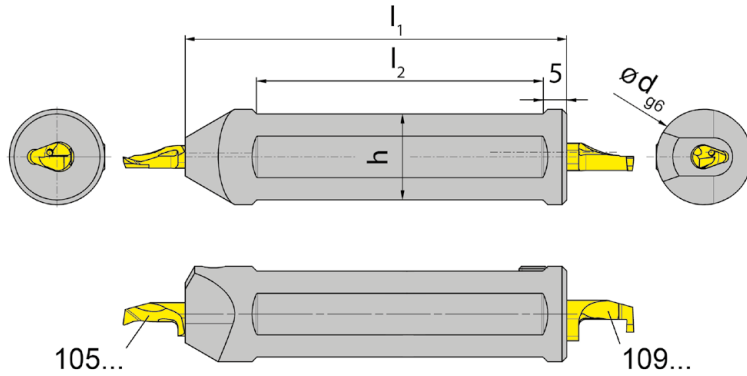
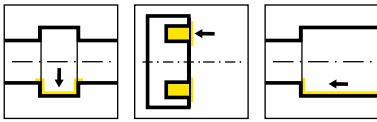

Abbildung = rechtsschneidend
Picture = right hand cutting version

Bestellnummer Part number	d	l ₁	h	l ₄	HWS
B105.0020.1.10	20	80	18	60	105123 • 105124 • 105125 • 110260

Ersatzteile

Spare Parts

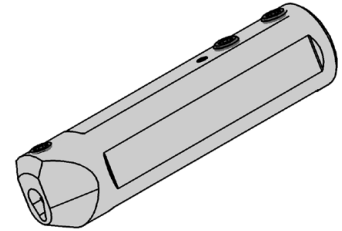
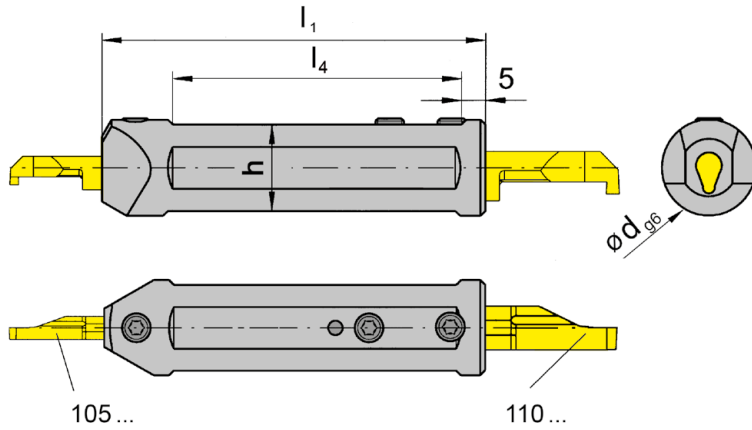
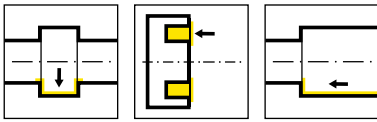
Klemmhalter Toolholder	Spannschraube Clamping Screw	TORX PLUS®-Schlüssel TORX PLUS® Wrench
B105.0020.1.10	6.075T15P	T15PQ



Abbildung = rechtsschneidend
Picture = right hand cutting version

Bestellnummer Part number	d	l ₁	Maschinentyp Machine type	HWS
IR.105.34.100.IK	3/4"	100	Citizen	105123 • 105124 • 105125
IR.105.34.40.IK	3/4"	40	Citizen	105123 • 105124 • 105125
IR.105.34.50.IK	3/4"	50	Citizen	105123 • 105124 • 105125
IR.105.34.70.IK	3/4"	70	Citizen	105123 • 105124 • 105125
IR.105.10.100.IK	1"	100	Citizen	105123 • 105124 • 105125
IR.105.10.60.IK	1"	60	Citizen	105123 • 105124 • 105125
IR.105.20.30.IK	20	30	Citizen	105123 • 105124 • 105125
IR.105.20.50.IK	20	50	Citizen	105123 • 105124 • 105125
IR.105.16.100.IK	16	100	Star	105123 • 105124 • 105125
IR.105.16.30.IK	16	30	Star	105123 • 105124 • 105125
IR.105.16.50.IK	16	50	Star	105123 • 105124 • 105125
IR.105.16.70.IK	16	70	Star	105123 • 105124 • 105125
IR.105.20.100.IK	20	100	Star	105123 • 105124 • 105125
IR.105.22.100.IK	22	100	Star	105123 • 105124 • 105125
IR.105.22.120.3.IK	22	120	Star	105123 • 105124 • 105125
IR.105.22.120.IK	22	120	Star	105123 • 105124 • 105125
IR.105.22.150.IK	22	150	Star	105123 • 105124 • 105125
IR.105.22.38.IK	22	38	Star	105123 • 105124 • 105125
IR.105.22.50.IK	22	50	Star	105123 • 105124 • 105125
IR.105.22.70.IK	22	70	Star	105123 • 105124 • 105125
IR.105.20.170.IK	20	170	Tornos	105123 • 105124 • 105125
IR.105.20.185.IK	20	185	Tornos	105123 • 105124 • 105125
IR.105.25.100.IK	25	100	Tornos	105123 • 105124 • 105125
IR.105.25.150.IK	25	150	Tornos	105123 • 105124 • 105125
IR.105.28.80.IK	28	80	Tornos	105123 • 105124 • 105125

Abmessungen in inch und mm
Dimensions in inch and mm

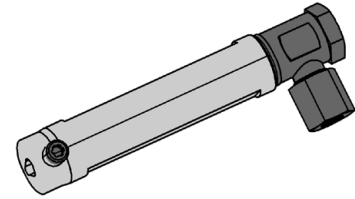
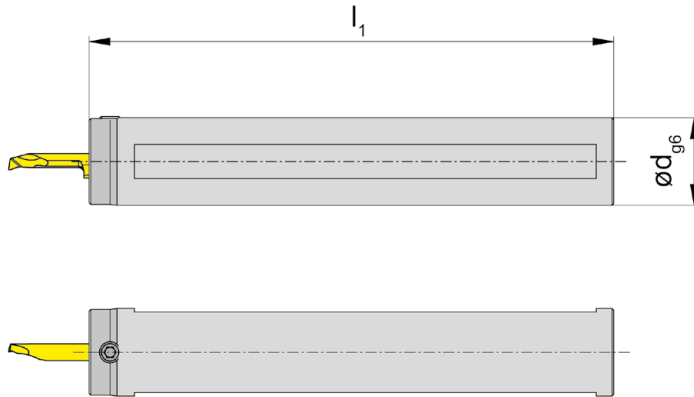
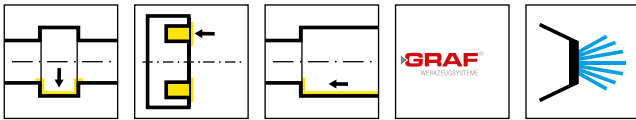

Abbildung = rechtsschneidend
Picture = right hand cutting version

Bestellnummer Part number	d_1	l_1	l_2	HWS
IR.105.1640.IKV	16	40	25	105123 • 105124 • 105125
IR.105.3440.IKV	3/4"	40	25	105123 • 105124 • 105125
IR.105.2040.IKV	20	40	25	105123 • 105124 • 105125
IR.105.2240.IKV	22	40	25	105123 • 105124 • 105125
IR.105.2560.IKV	25	60	25	105123 • 105124 • 105125
IR.105.1060.IKV	1"	60	25	105123 • 105124 • 105125

Abmessungen in inch und mm
Dimensions in inch and mm

Ersatzteile

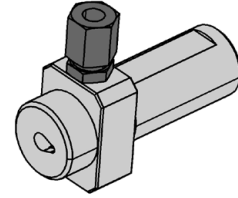
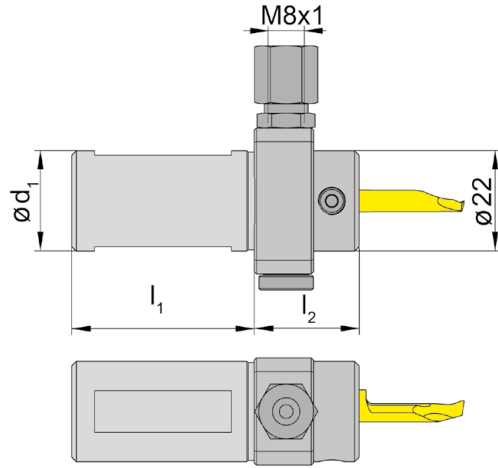
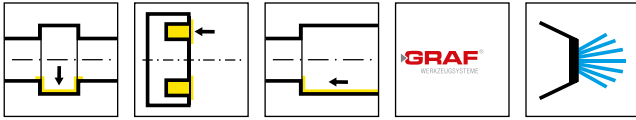
Spare Parts

Einbauhalter Graf Cartridge Graf	Spannschraube Clamping Screw	Kühlmittelanschluss Coolant supply	TORX PLUS®-Schlüssel TORX PLUS® Wrench
IR...	6.075T15P	004.00.19	T15PQ



Abbildung = rechtsschneidend
Picture = right hand cutting version

Bestellnummer Part number	d	l ₁	HWS
B105.0020.2.01	20	150	105123 • 105124 • 105125
B105.0025.2.01	25	150	105123 • 105124 • 105125

Stelling ist nicht im Lieferumfang enthalten - bitte separat bestellen!
Adjusting ring is not combined with the toolholder - separate order required!

Stelling Adjusting ring	d	Maschinentyp Type of machine
020.0020.1665	20	Tornos
020.0025.2234	25	Tornos

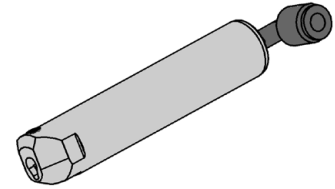
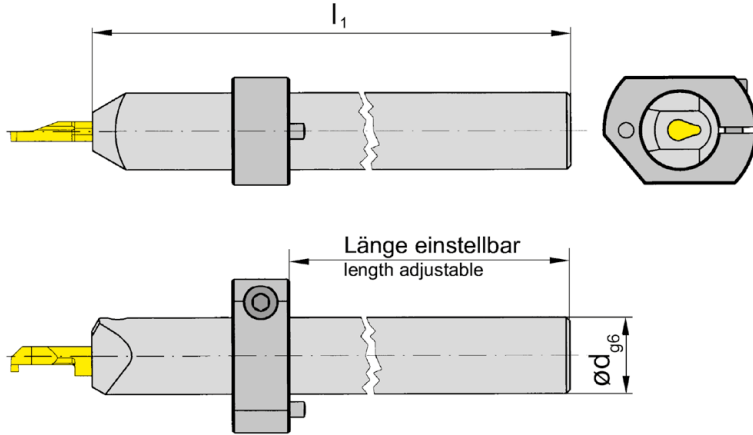
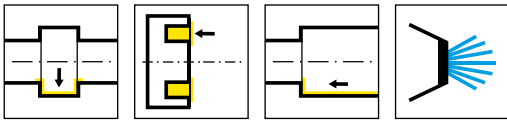
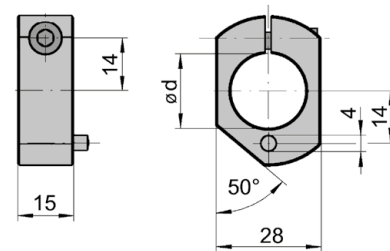

Ersatzteile
Spare Parts

Klemmhalter Toolholder	Spannschraube Clamping Screw	TORX PLUS®-Schlüssel TORX PLUS® Wrench
B105...	6.075T15P	T15PQ



Abbildung = rechtsschneidend
Picture = right hand cutting version

Bestellnummer Part number	d	l_1	h	l_4	f	d_2	SW	b	HWS
B105.0010.9.01	10	100	9	50	1,6	11	10	5,9	105123
B105.0012.11.01	12	100	11	50	1,2	16	13	7	105125
B105.0016.11.01	16	100	15	50	1,2	16	13	7	105125

b = Schneidplattenhöhe
b = Height of insert

Ersatzteile

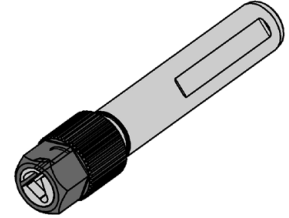
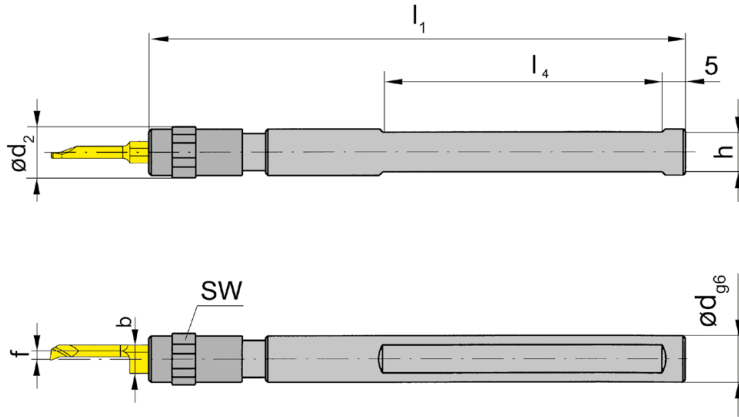
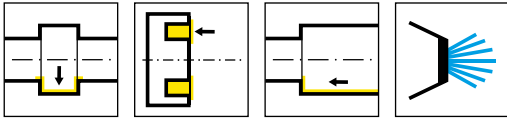
Spare Parts

Klemmhalter Toolholder	Spannmutter Clamping nut
B105.0010.9.01	020.0010.1719
B105.00...	020.0016.1999

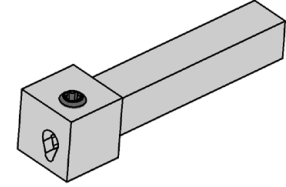
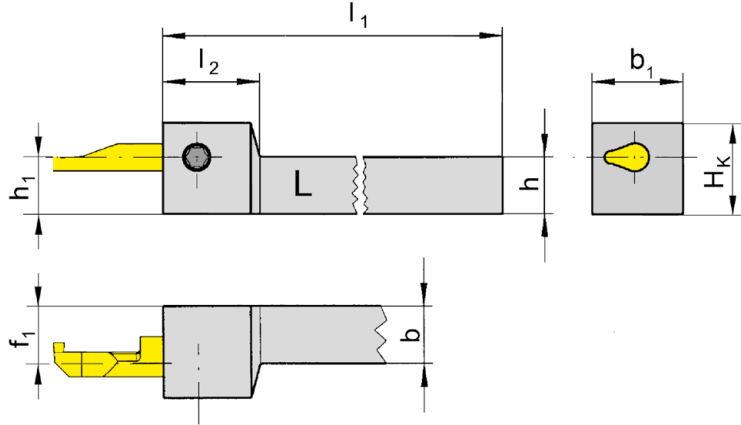
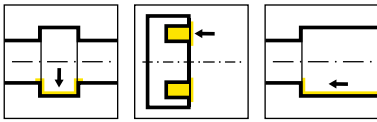

L = links wie gezeichnet
L = left hand version shown

R = rechts spiegelbildlich
R = right hand version

Bestellnummer Part number	h	b	l ₁	h ₁	b ₁	f ₁	H _k	l ₂	HWS
RH105.0808.01	8	8	90	8	16	7,5	14	17	105123 • 105124 • 105125
RH105.1010.01	10	10	90	10	16	7,5	16	17	105123 • 105124 • 105125
RH105.1212.01	12	12	90	12	16	7,5	18	17	105123 • 105124 • 105125
RH105.1616.01	16	16	110	16	16	7,5	22	17	105123 • 105124 • 105125
LH105.0808.01	8	8	90	8	16	7,5	14	17	105123 • 105124 • 105125
LH105.1010.01	10	10	90	10	16	7,5	16	17	105123 • 105124 • 105125
LH105.1212.01	12	12	90	12	16	7,5	18	17	105123 • 105124 • 105125
LH105.1616.01	16	16	110	16	16	7,5	22	17	105123 • 105124 • 105125

Ersatzteile
Spare Parts

Klemmhalter Toolholder	Spannschraube Clamping Screw	TORX PLUS®-Schlüssel TORX PLUS® Wrench
R/LH105...	6.075T15P	T15PQ

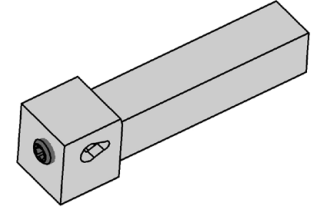
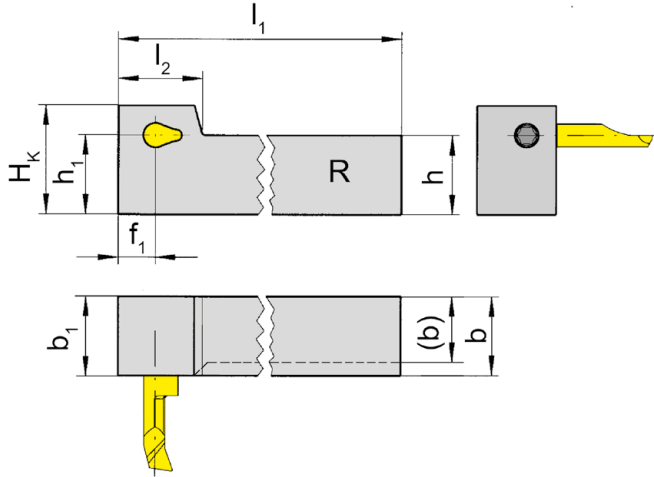
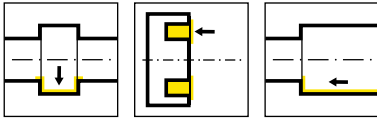

R = rechts wie gezeichnet
R = right hand version shown

L = links spiegelbildlich
L = left hand version

Bestellnummer Part number	h	b	l ₁	l ₂	h ₁	b ₁	f ₁	H _k	HWS
RHC105.1212.01	12	12	90	17	12	16	7,5	18	105123 • 105124 • 105125
RHC105.1616.01	16	16	130	17	16	16	7,5	22	105123 • 105124 • 105125
LHC105.1212.01	12	12	90	17	12	16	7,5	18	105123 • 105124 • 105125
LHC105.1616.01	16	16	130	17	16	16	7,5	22	105123 • 105124 • 105125

Ersatzteile

Spare Parts

Klemmhalter Toolholder	Spannschraube Clamping Screw	TORX PLUS®-Schlüssel TORX PLUS® Wrench
R/LHC105...	6.075T15P	T15PQ

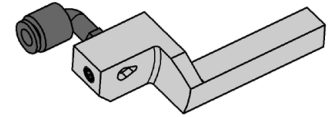
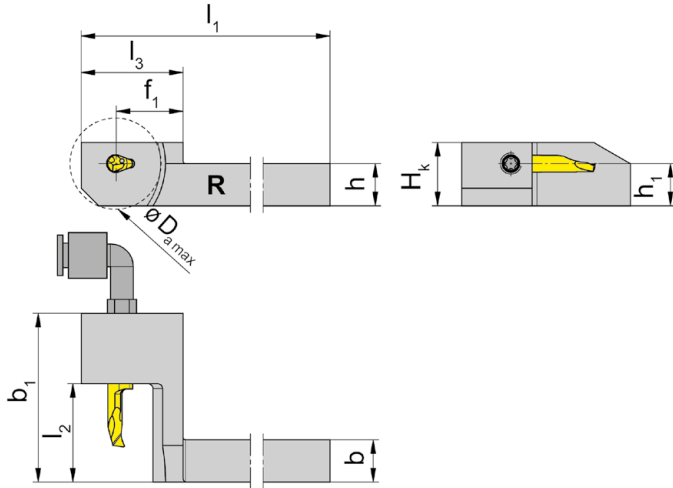
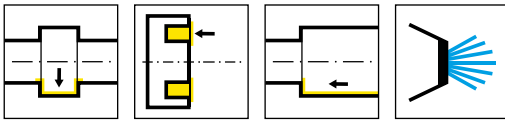

R = rechts wie gezeichnet
R = right hand version shown

L = links spiegelbildlich
L = left hand version

Bestellnummer Part number	h	b	l ₁	l ₃	h ₁	b ₁	f ₁	D _{a max}	H _K	l ₂	HWS
RHC105.0808.21	8	8	99	29	8	32	19	26	13	18	105123 • 105124 • 105125
RHC105.1010.11	10	10	99	29	10	22,7	19	26	16	8	105123 • 105124 • 105125
RHC105.1010.21	10	10	99	29	10	38	19	26	16	18	105123 • 105124 • 105125
RHC105.1010.41	10	10	99	29	10	48	19	26	16	28	105123 • 105124 • 105125
RHC105.1212.21	12	12	99	29	12	38	19	26	18	18	105123 • 105124 • 105125
RHC105.1212.41	12	12	99	29	12	48	19	26	18	28	105123 • 105124 • 105125
RHC105.1616.21	16	16	104	34	16	38	24	36	22	18	105123 • 105124 • 105125
RHC105.1616.41	16	16	104	34	16	48	24	36	22	28	105123 • 105124 • 105125
LHC105.0808.21	8	8	99	29	8	32	19	26	13	18	105123 • 105124 • 105125
LHC105.1212.21	12	12	99	29	12	38	19	26	18	18	105123 • 105124 • 105125
LHC105.1616.21	16	16	104	34	16	38	24	36	22	18	105123 • 105124 • 105125

Kühlmittelzufuhr über Winkelverschraubung
Coolant supply through cranked fitting

R/LHC105.08.../.1010.11 ohne Innenkühlung
R/LHC105.08.../.1010.11 without trough coolant

Ersatzteile
Spare Parts

Klemmhalter Toolholder	Spannschraube Clamping Screw	TORX PLUS®-Schlüssel TORX PLUS® Wrench
R/LHC105...	6.075T15P	T15PQ

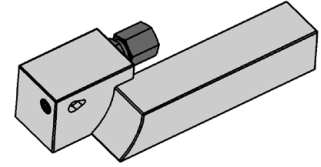
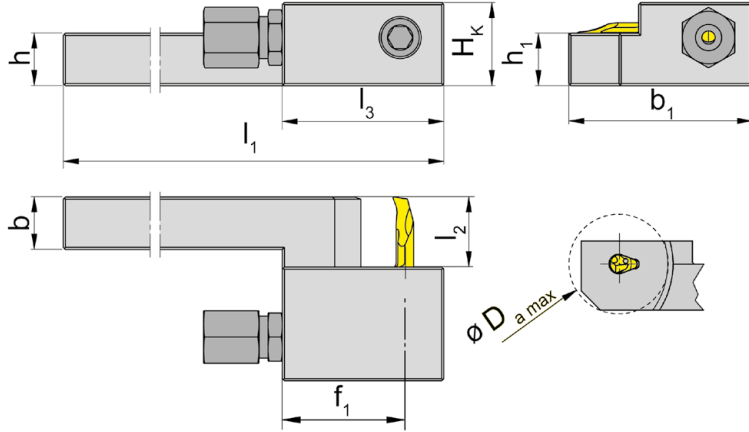
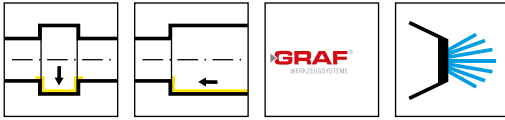

R = rechts wie gezeichnet
R = right hand version shown

L = links spiegelbildlich
L = left hand version

Bestellnummer Part number	h	b	f ₁	l ₁	l ₃	h ₁	H _k	b ₁	l ₂	D _{a max}	HWS
962.08.01.R.IK	8	8	27	130	37	8	15	42	18	30	105123 • 105124 • 105125
962.08.02.L.IK	8	8	27	130	37	8	15	42	18	30	105123 • 105124 • 105125
962.10.01.R.IK	10	10	27	130	37	10	17	42	18	30	105123 • 105124 • 105125
962.10.02.L.IK	10	10	27	130	37	10	17	42	18	30	105123 • 105124 • 105125
962.10.03.R.IK	10	10	27	130	37	10	17	57	33	30	105123 • 105124 • 105125
962.10.04.L.IK	10	10	27	130	37	10	7	57	33	30	105123 • 105124 • 105125
962.12.01.R.IK	12	12	27	130	37	12	19	42	18	30	105123 • 105124 • 105125
962.12.02.L.IK	12	12	27	130	37	12	19	42	18	30	105123 • 105124 • 105125
962.12.03.R.IK	12	12	27	130	37	12	19	57	33	30	105123 • 105124 • 105125
962.12.04.L.IK	12	12	27	130	37	12	19	57	33	30	105123 • 105124 • 105125
962.16.01.R.IK	16	16	27	130	37	16	23	42	18	34	105123 • 105124 • 105125
962.16.02.L.IK	16	16	27	130	37	16	23	42	18	34	105123 • 105124 • 105125
962.16.03.R.IK	16	16	27	130	37	16	23	57	33	34	105123 • 105124 • 105125
962.16.04.L.IK	16	16	27	130	37	16	23	57	33	34	105123 • 105124 • 105125
962.20.01.R.IK	20	20	27	130	37	20	27	42	18	34	105123 • 105124 • 105125
962.20.02.L.IK	20	20	27	130	37	20	27	42	18	34	105123 • 105124 • 105125

Kühlmittelzufuhr über Verschraubung
Coolant through fitting

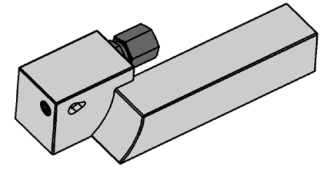
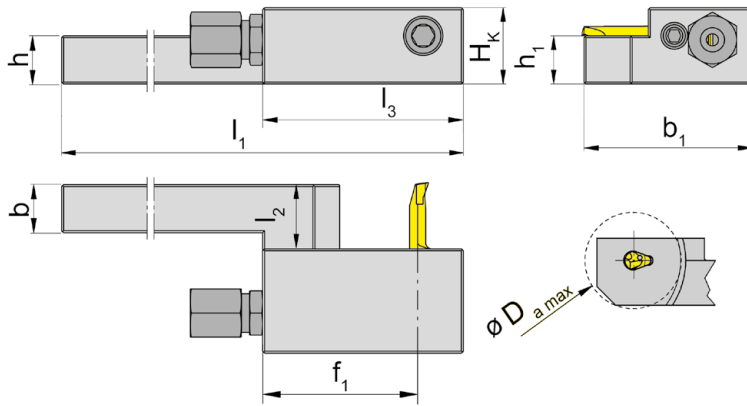
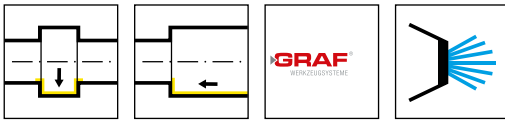

R = rechts wie gezeichnet
R = right hand version shown

L = links spiegelbildlich
L = left hand version

Bestellnummer Part number	h	b	f ₁	l ₁	l ₃	h ₁	H _k	b ₁	l ₂	D _{a max}	HWS
963.12.01.R.IK	12	12	40	130	50	12	19	42	18	46	105123 • 105124 • 105125
963.12.02.L.IK	12	12	40	130	50	12	19	42	18	46	105123 • 105124 • 105125
963.16.01.R.IK	16	16	45	130	50	16	23	42	18	52	105123 • 105124 • 105125
963.16.02.L.IK	16	16	45	130	50	16	23	42	18	52	105123 • 105124 • 105125

Kühlmittelzufuhr über Verschraubung
Coolant through fitting

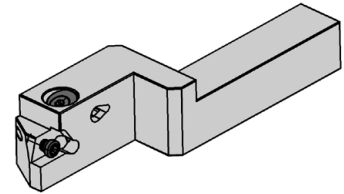
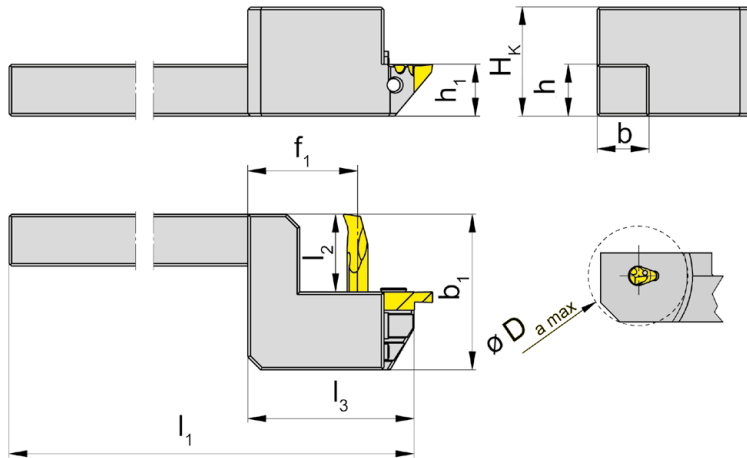
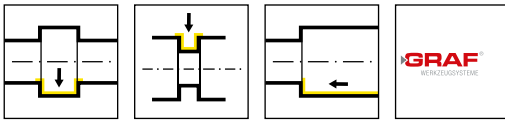

R = rechts wie gezeichnet
R = right hand version shown

L = links spiegelbildlich
L = left hand version

Bestellnummer Part number	h	b	f ₁	l ₁	l ₃	h ₁	H _k	b ₁	l ₂	D _{a max}	HWS
AIH.974.R.1212.K04	12	12	23	130	50	12	19	33	16,5	20	105123 • 105124 • 105125 • 274040R
AIH.974.R.1616.K04	16	16	26	130	50	16	23	33	16,5	26	105123 • 105124 • 105125 • 274040R
AIH.974.R.2020.K04	20	20	29	130	55	20	27	33	16,5	32	105123 • 105124 • 105125 • 274040R

Ersatzteile

Spare Parts

Klemmhalter Toolholder	Spannschraube Clamping Screw	TORX PLUS®-Schlüssel TORX PLUS® Wrench
AIH...	6.075T15P	T15PQ

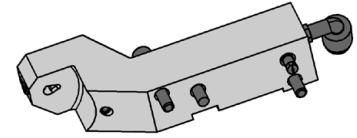
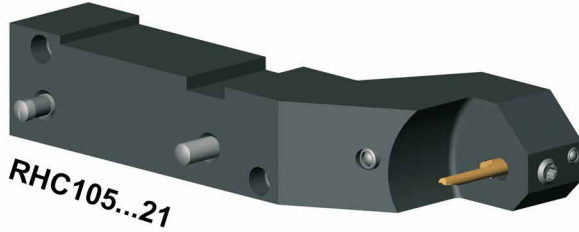
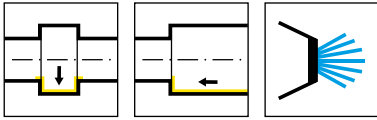

Bestellnummer Part number	Maschinentyp Machine type	Schneidplatte Insert	HWS	HMS
RHC105.0710.21	EvoDECO 10	105...21 L ₂ bis/up to 15 mm	105123 • 105124 • 105125	Tornos
RHC105.0710.41	EvoDECO 10	105...41 L ₂ bis/up to 25 mm	105123 • 105124 • 105125	Tornos

Werkzeug für Tornos
Tool for Tornos

Ersatzteile
Spare Parts

Grundhalter Basic toolholder	Spannschraube Clamping Screw	TORX PLUS®-Schlüssel TORX PLUS® Wrench
RHC105...	6.075T15P	T15PQ

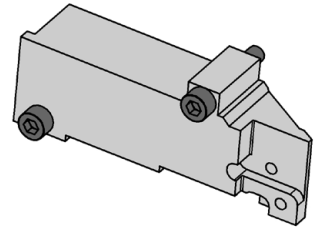
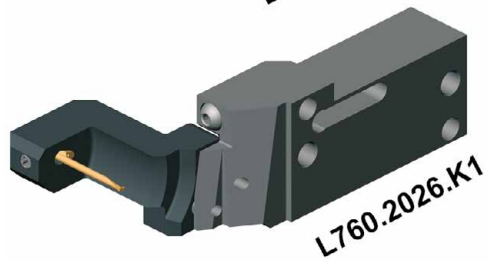
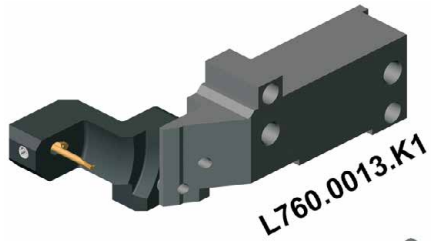
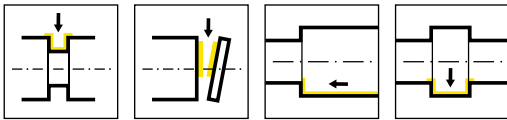

Bestellnummer Part number	Schneidplatte Insert	Kassette Cassette	Maschinentyp Machine type
L760.0013.K1	105...21 l ₂ bis/up to 15 mm	RKC760.0105.21	EvoDECO 16
L760.2026.K1	105...41 l ₂ bis/up to 25 mm	RKC760.0105.41	EvoDECO 20/EvoDECO 32

Werkzeug für Tornos
Tool for Tornos

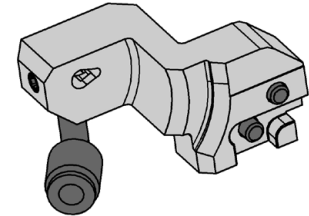
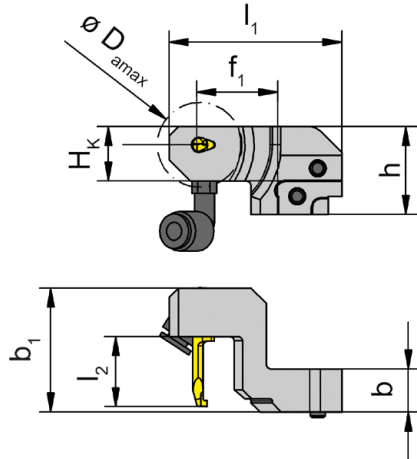
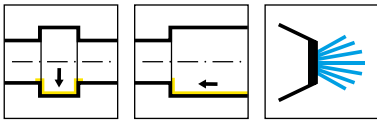

Bestellnummer Part number	l_1	l_2	b_1	b	h	H_k	f_1	$D_{a\ max}$	HWS
RKC760.0105.21	57	24,9	40,9	14,2	29	18	26	28	105123 • 105124 • 105125
RKC760.0105.41	57	34,9	50,9	14,2	29	18	26	28	105123 • 105124 • 105125

Werkzeug für Tornos Grundhalter L760
Tool for Tornos Basic toolholder L760

Ersatzteile
Spare Parts

Kassette Cassette	Spannschraube Clamping Screw	TORX PLUS®-Schlüssel TORX PLUS® Wrench
RKC760...	5.12T20P	T15PQ

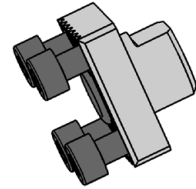
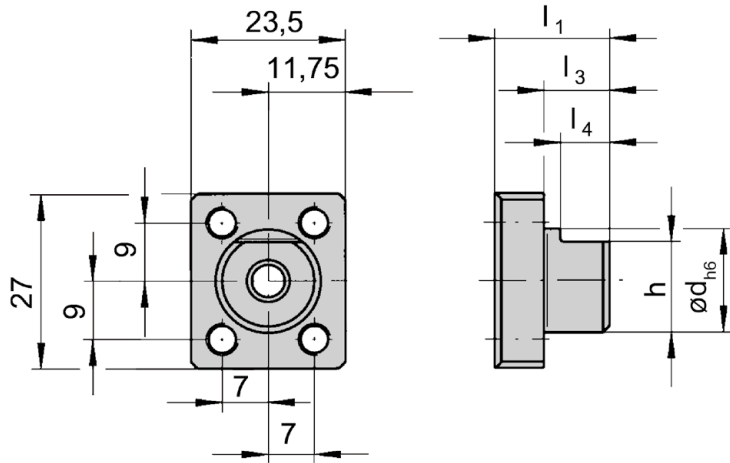
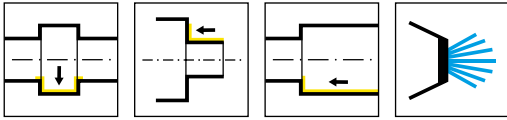

Bestellnummer Part number	h	d	l ₁	l ₃	l ₄	Maschinentyp Machine type	HMS
BGT001.1627.10	14	16	17,5	10	7,5	Star	Kerbverzahnung 90° / T3

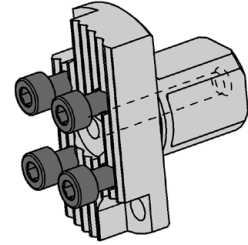
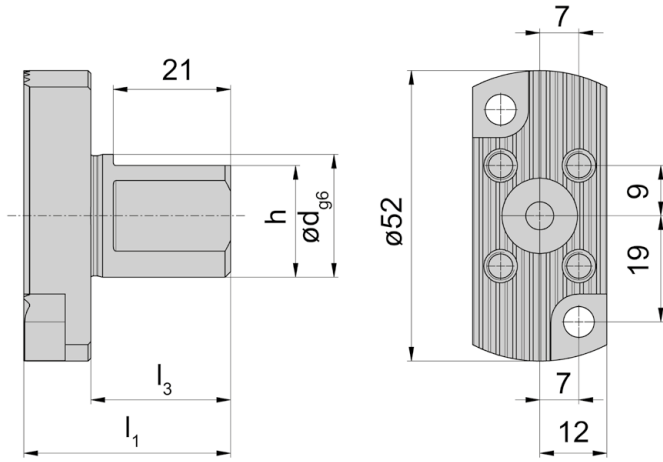
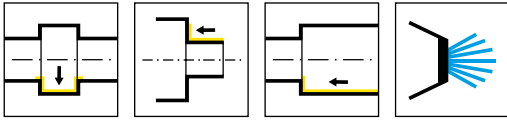

Bestellnummer Part number	h	d	l ₁	l ₃	l ₄	HMS
BGT001.0R22.25	20	22	37	25	21	Kerbverzahnung 90° / T3

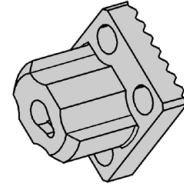
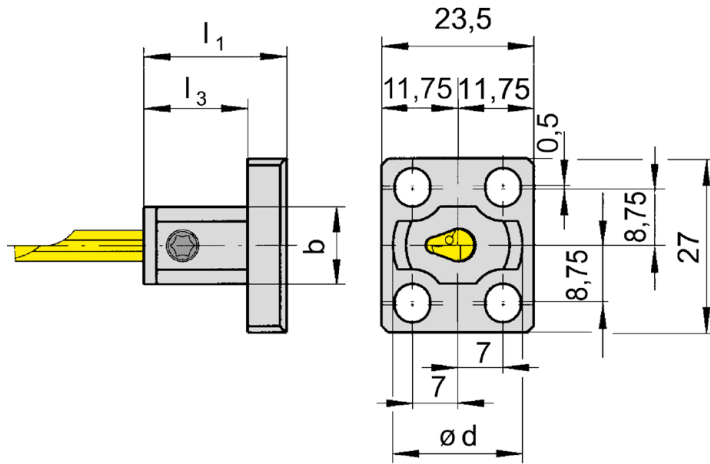
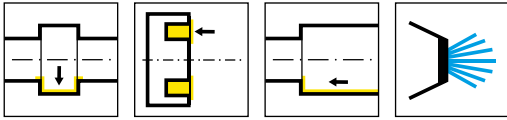

Bestellnummer Part number	d	l ₁	l ₃	b	HWS	HMS
BKT105.2327.01	20	22	16	12	105123 • 105124 • 105125	Kerbverzahnung 90° / T3

Ersatzteile

Spare Parts

Einstellbare Halter Adjustable holder	Spannschraube Clamping Screw	TORX PLUS®-Schlüssel TORX PLUS® Wrench
BKT105.2327.01	6.075T15P	T15PQ

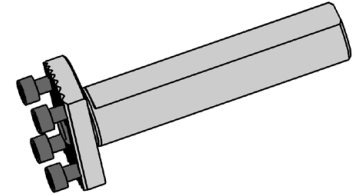
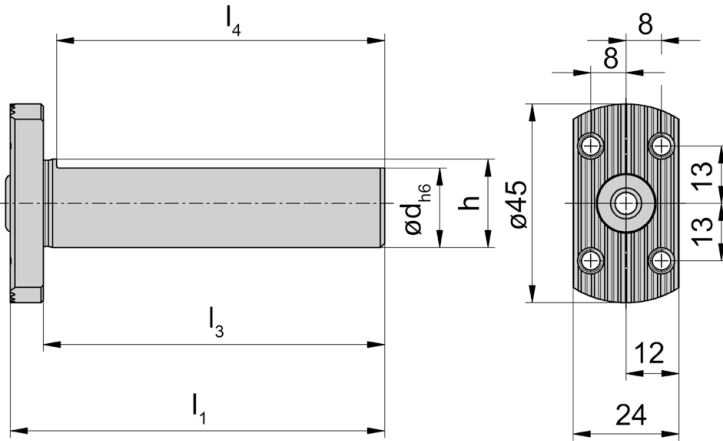
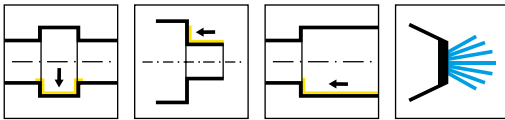

Bestellnummer Part number	h	d	l ₁	l ₃	l ₄	Maschinentyp Machine type	HMS
BGT001.0010.50	9	10	57,5	50	47		Kerbverzahnung 90° / T3
BGT001.0016.21	14	16	28,5	21	18	Star	Kerbverzahnung 90° / T3
BGT001.0R16.21	14	16	28,5	21	18	Star	Kerbverzahnung 90° / T3
BGT001.0020.100	18	20	107,5	100	97	Tornos	Kerbverzahnung 90° / T3
BGT001.0022.30	20	22	36,35	30	27	Star	Kerbverzahnung 90° / T3
BGT001.0025.70	23	25	77,5	70	67		Kerbverzahnung 90° / T3

BGT001.0022.30 ohne innere Kühlmittelzufuhr
BGT001.0022.30 without through coolant supply

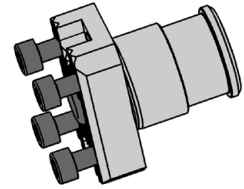
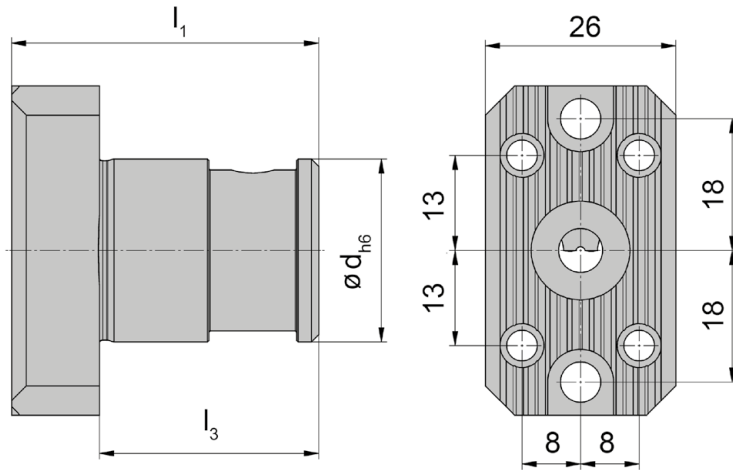
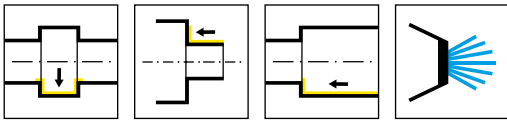

Bestellnummer Part number	d	l ₁	l ₃	Maschinentyp Machine type	HMS
BGT001.C025.30IK	25	42	30	Citizen L20X	Kerbverzahnung 90° / T3

Einstellbare Halter

Adjustable holder

BKT



A

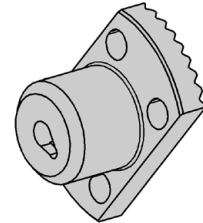
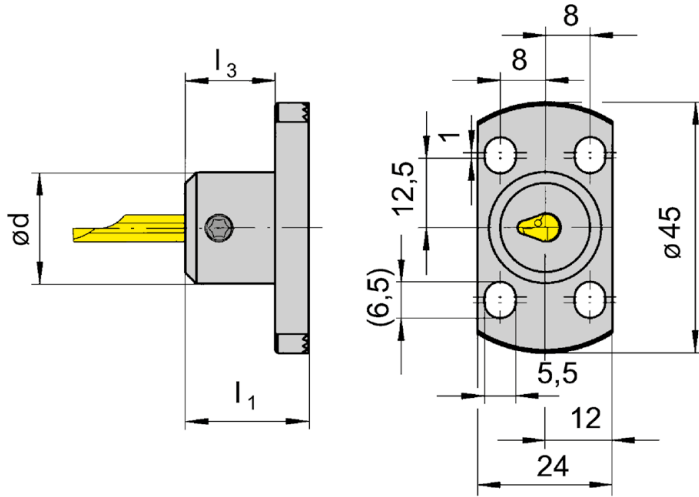
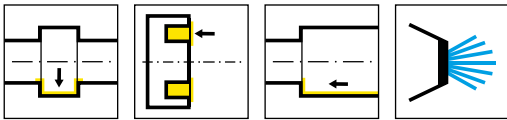

Bestellnummer Part number	d	l ₁	l ₃	HWS	HMS
BKT105.2445.01	20	22	16	105123 • 105124 • 105125	Kerbverzahnung 90° / T3
BKT105.2445.02	20	32	26	105225	Kerbverzahnung 90° / T3

Ersatzteile

Spare Parts

Einstellbare Halter Adjustable holder	Spannschraube Clamping Screw	TORX PLUS®-Schlüssel TORX PLUS® Wrench
BKT105...	6.075T15P	T15PQ

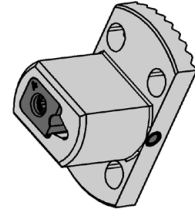
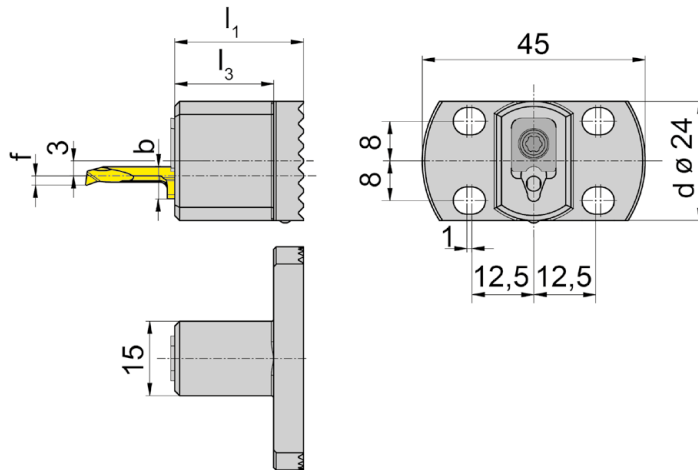
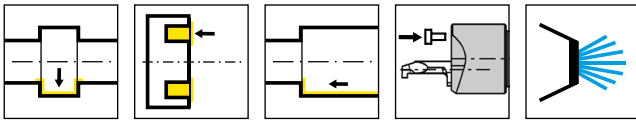

Bestellnummer Part number	l_1	d	l_3	b	HWS	HMS
BKT105.2445.S.03	26	24	20	5,9	105123	Kerbverzahnung 90° / T3
BKT105.2445.S.04	26	24	20	6,4	105124	Kerbverzahnung 90° / T3
BKT105.2445.S.05	26	24	20	7	105125	Kerbverzahnung 90° / T3

f siehe Schneidplatte Typ 105
f see inserts type 105

Ersatzteile

Spare Parts

Einstellbare Halter Adjustable holder	Spannelement Clamping element	TORX PLUS®-Schlüssel TORX PLUS® Wrench
BKT105.2445.S.03	010.0105.03	T15PL
BKT105.2445.S.04	010.0105.04	T15PL
BKT105.2445.S.05	010.0105.05	T15PL

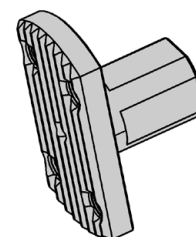
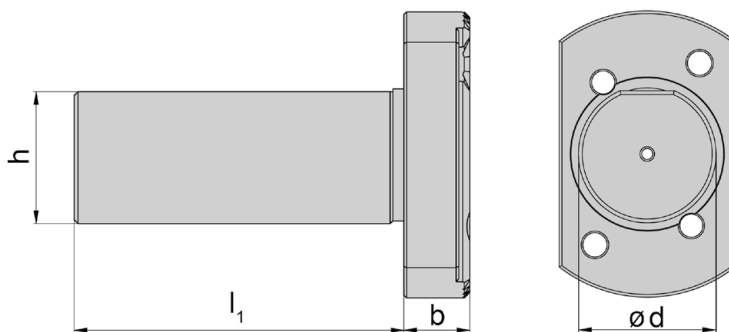
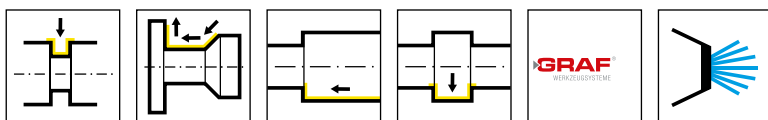

Bestellnummer Part number	d	l ₁	h	b	Maschinentyp Machine type
G.016.021	16	21	14	6	Star
G.016.040	16	40	14	6	Traub/Manurhin
G.034.040	3/4"	40	18	6	Citizen
G.034.050	3/4"	50	18	6	Citizen
G.034.120	3/4"	120	18	6	Citizen
G.020.030	20	30	18	6	Citizen
G.020.040	20	40	18	6	Citizen
G.020.100	20	100	18	6	Citizen
G.020.150	20	150	18	6	Citizen
G.022.023	22	23	20	6	Star
G.022.030	22	30	20	6	Star
G.022.070	22	70	20	6	Star
G.025.060	25	60	23	12	Hanwha
G.025.070	25	70	23	6	Manurhin/Tornos
G.025.100	25	100	23	6	Manurhin/Tornos
G.025.160	25	160	23	6	Manurhin/Tornos
G.010.060	1"	60	23	12	Citizen
G.010.100	1"	100	23	6	Citizen
G.028.006	28	6	26	6	Hanwha
G.028.080	28	80	26	12	Traub
G.034.020	34	20	32	12	Maier
G.034.044	34	44	32	12	Maier/Hanwha

Abmessungen in inch und mm
Dimensions in inch and mm

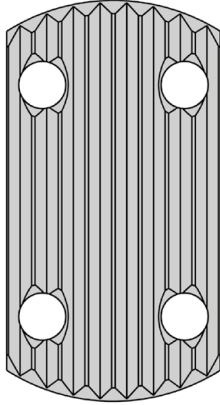

A

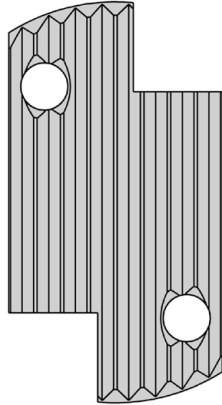

B

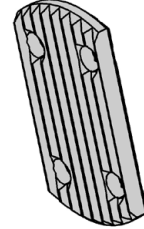
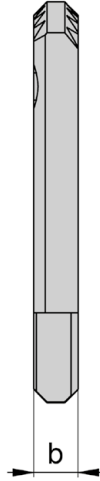

Bestellnummer Part number	b	Form
Z.5	5	A
Z.10	10	A
Z.15	15	A
Z.20	20	A
Z.25	25	A
Z.30	30	A
Z10SR16/20R	10	B
Z25SR16/20R	25	B
Z30SR16/20R	30	B



Rückseitenbearbeitung

Back working

passend für Halter Graf Typ N und HORN BKT105.2445.01/02 und BKT105.2445.S.03/04/05
suitable for holder Graf type N and HORN BKT105.2445.01/02 and BKT105.2445.S.03/04/05

Bestellnummer **N11**

Part number

Für wahlweise 2 Einsätze
For alternatively 2 cartridges

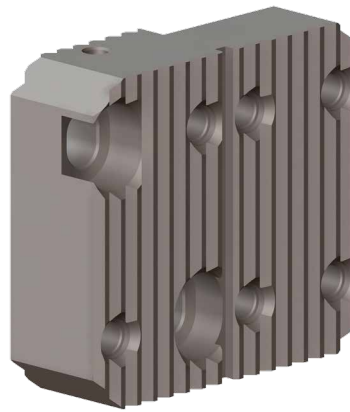

Bestellnummer **N12**

Part number

Für wahlweise 3 Einsätze
For alternatively 3 cartridges

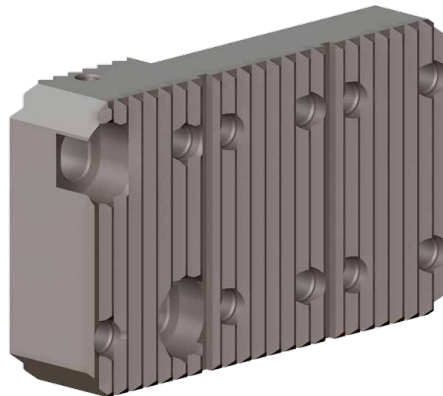

Bestellnummer **N93IK**

Part number

mit innerer Kühlmittelzufuhr
with through coolant supply

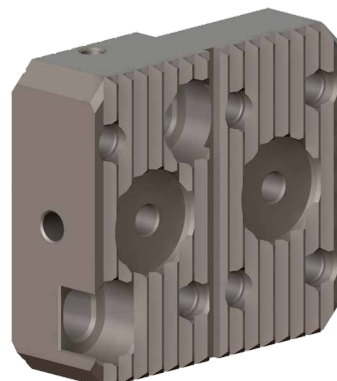



Abbildung = rechtsschneidend
Picture = right hand cutting version

Bestellnummer Part number	l_1	l_3	HWS
N.09.IK	40	15	105123 • 105124 • 105125

Das Kühlmittelrohr ist nicht im Lieferumfang enthalten - bitte separat bestellen!
Coolant tube is not included - separate order required!

Ersatzteile

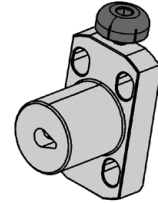
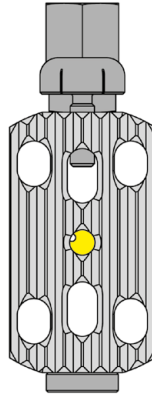
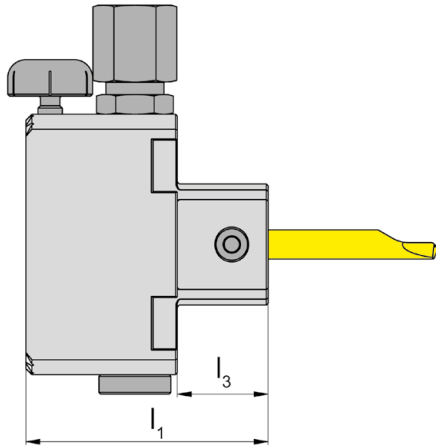
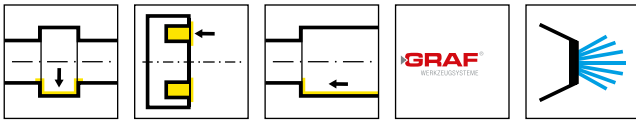
Spare Parts

Einstellbare Halter Adjustable holder	Spannschraube Clamping Screw	Kühlmittelanschluss Coolant supply
N.09.IK	6.075T15P	004.00.19

Einstellbare Halter

Adjustable holder

N



A



Abbildung = rechtsschneidend
Picture = right hand cutting version

Bestellnummer Part number	l_1	l_3	HWS
N.09	30	20	105123 • 105124 • 105125

Ersatzteile

Spare Parts

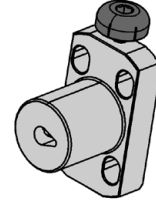
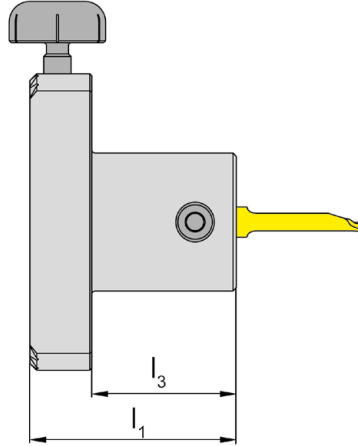
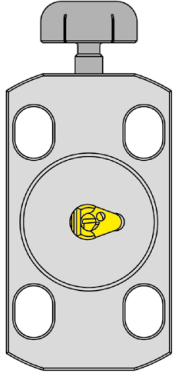
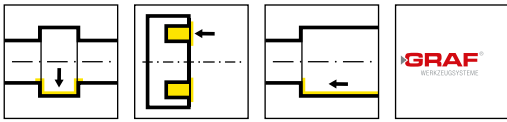
Einstellbare Halter Adjustable holder	Spannschraube Clamping Screw
N.09	6.075T15P



Abbildung = rechtsschneidend
Picture = right hand cutting version

Bestellnummer Part number	l_1	l_3	HWS
N.73.IK	40	15	105123 • 105124 • 105125

Das Kühlmittelrohr ist nicht im Lieferumfang enthalten - bitte separat bestellen!
Coolant tube is not included - separate order required!

Ersatzteile

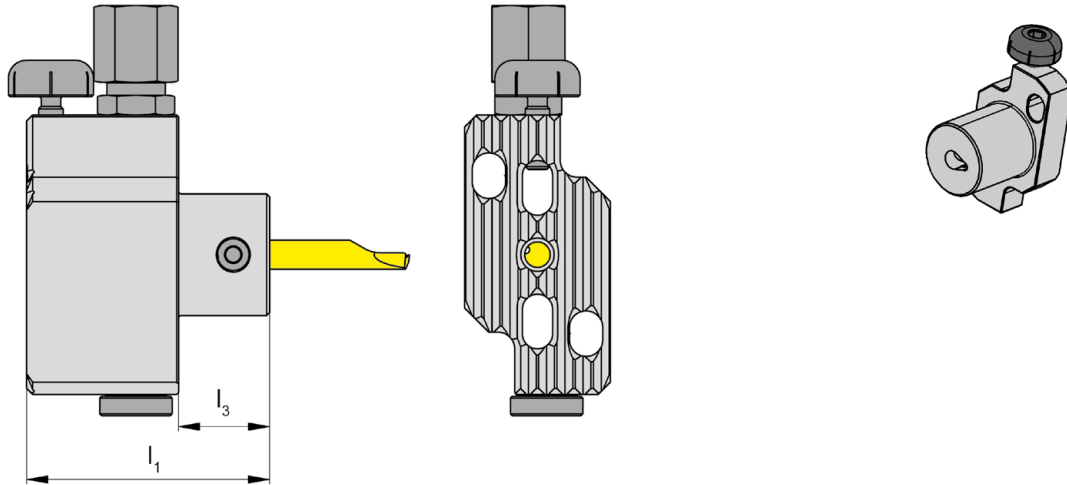
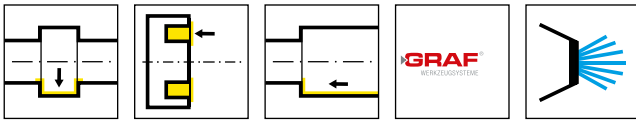
Spare Parts

Einstellbare Halter Adjustable holder	Spannschraube Clamping Screw	Kühlmittelanschluss Coolant supply
N.73.IK	6.075T15P	004.00.19

Einstellbare Halter

Adjustable holder

N



A



Abbildung = rechtsschneidend
Picture = right hand cutting version

Bestellnummer Part number	l_1	l_3	HWS
N.73	30	20	105123 • 105124 • 105125

Ersatzteile

Spare Parts

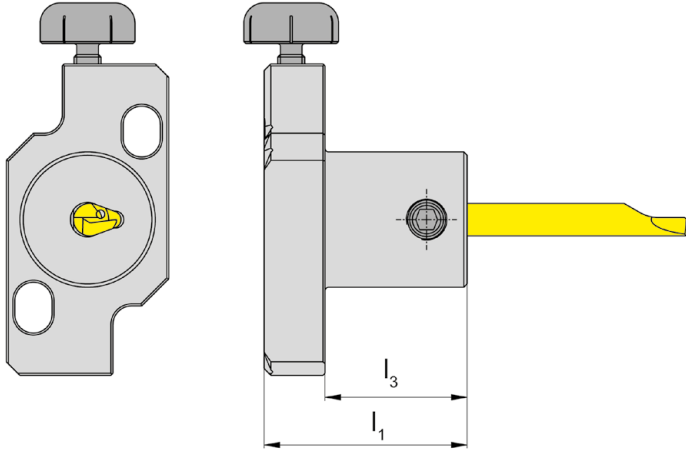
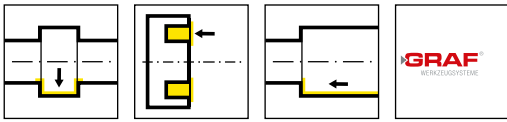
Einstellbare Halter Adjustable holder	Spannschraube Clamping Screw
N.73	6.075T15P

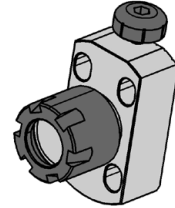
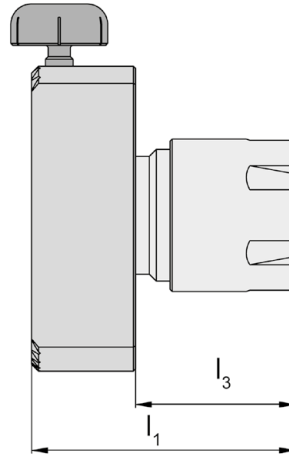
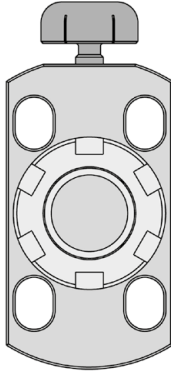
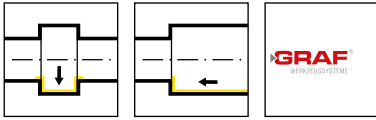

Bestellnummer Part number	l_1	l_3	Spannmutter Clamping nut
N.07	37	18	ER16

Einstellbare Halter

Adjustable holder

N



A

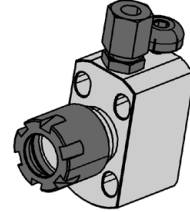
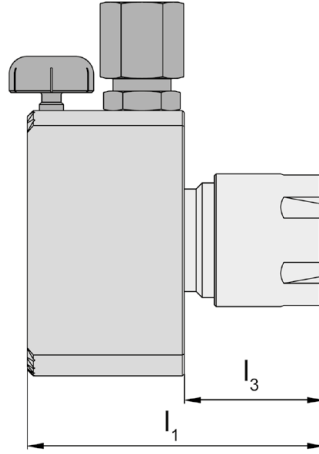
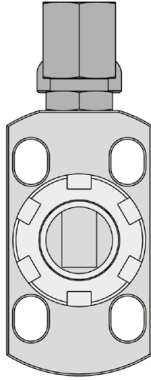
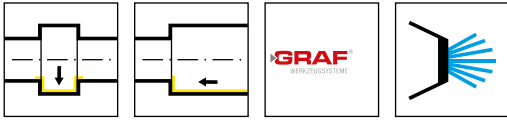

Bestellnummer Part number	l_1	l_3	Spannmutter Clamping nut
N.07.IK	54	18	ER16
N.41.IK	64	26	ER20

Das Kühlmittelrohr ist nicht im Lieferumfang enthalten - bitte separat bestellen!
Coolant tube is not included - separate order required!

Ersatzteile

Spare Parts

Einstellbare Halter Adjustable holder	Kühlmittelanschluss Coolant supply
N...	004.00.19

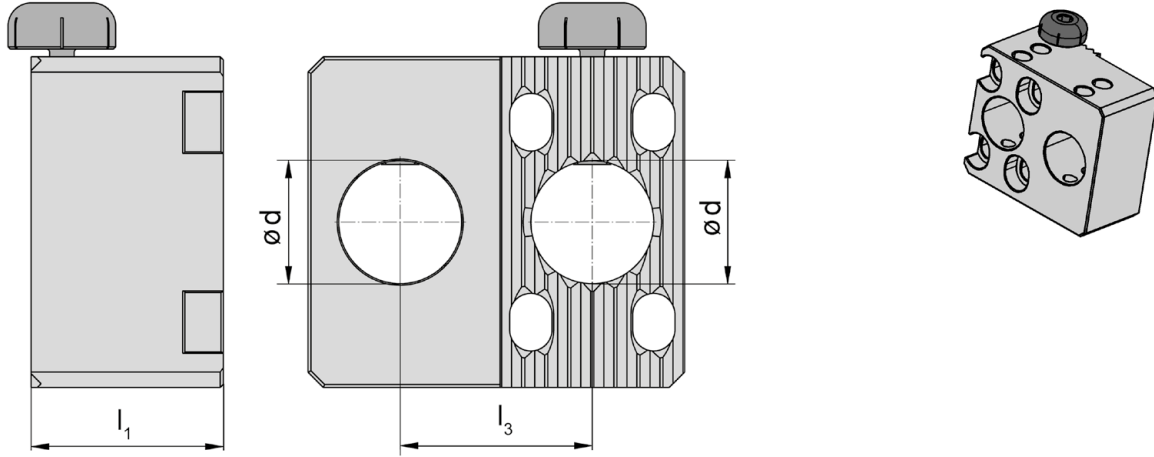
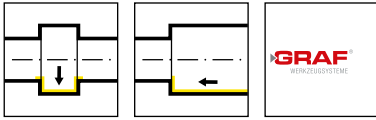

Bestellnummer Part number	d	l ₁	l ₃
N.10	16	25	25

Die Spannzangenaufnahmen sind nicht im Lieferumfang enthalten - bitte separat bestellen!
The collet adaptors are not included - separate order required!

Kühlmittelanschluss Standard für Rohr Ø 6 mm

Standard connection for coolant supply for pipe Ø 6 mm

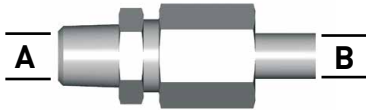

Kühlmittelanschluss, gerade
Connection for coolant supply
straight screwed

Bestellnummer Part number	A	B
004.00.19	M8 x 1	ø 6 mm
004.00.14	G1/8"	ø 6 mm

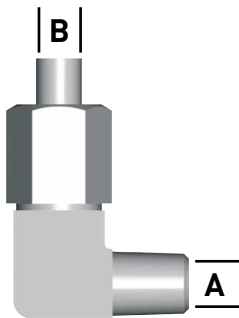

Kühlmittelanschluss,
winkelig fest
Connection for coolant supply
angled and fix

Bestellnummer Part number	A	B
004.00.22	M8 x 1	ø 6 mm
004.00.33	G1/8"	ø 6 mm

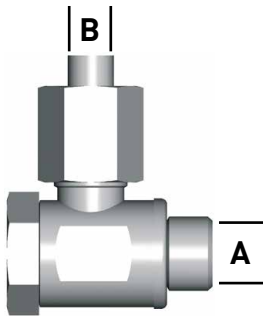

Schwenkverschraubung
Swivelling screw-fitting

Bestellnummer Part number	A	B
004.00.61	M8 x 1	ø 6 mm
004.00.16	G1/8"	ø 6 mm

Kühlmittelanschluss Schnellkupplung

Clip connection for coolant supply

Schnellkupplung
Quick connector

M10 x 1 - 004.00.49

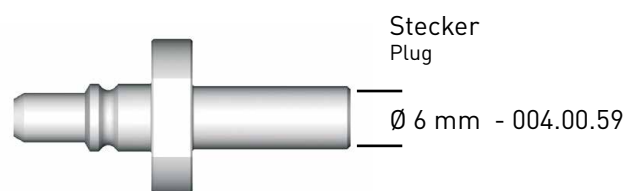
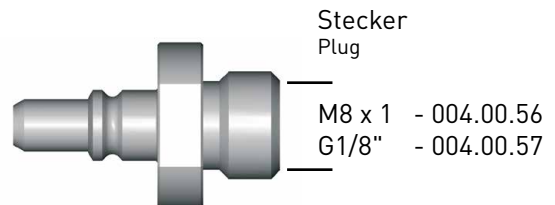

Spannmutter

Chucking nut



ER-M

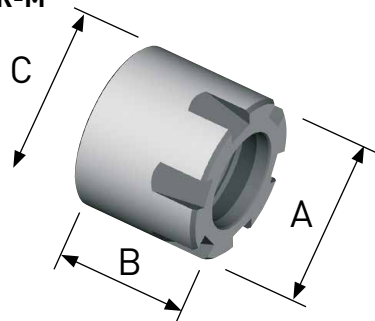

ER-M	A	B	C
62 000 08-ER 8	12	10,8	M10x0,75
62 000 11-ER 11	16	12	M13x0,75
62 000 16-ER 16	22	18	M19x1
62 000 20-ER 20	28	19	M24x1
62 000 25-ER 25	35	20	M30x1

ER-MA abdichtbar sealed

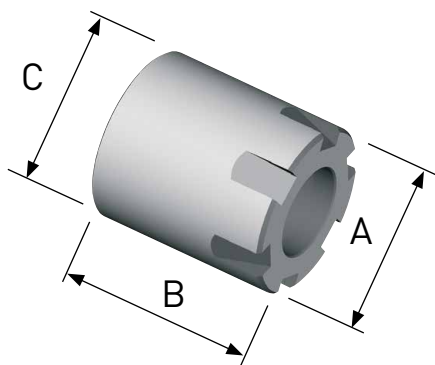

ER-MA	A	B	C
62 600 16-ER 16	22	24,5	M19x1
62 600 20-ER 20	28	26,5	M24x1
62 600 25-ER 25	35	27,5	M30x1

Dichtscheiben

für abdichtbare Spannmutter ER-MA...

Sealing rings

for chucking nuts ER-MA...

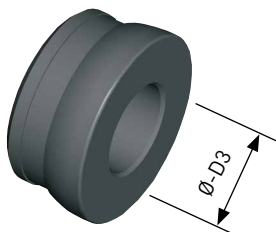

kompletter Satz:
completed set:

Bestellnummer Part number	Ø D3
64 600 16-ER 16	3,0-3,5...9,5-10,0 mm
64 600 20-ER 20	3,0-3,5...12,5-13,0 mm
64 600 25-ER 25	3,0-3,5...15,5-16,0 mm

Die Dichtscheiben können auch einzeln bestellt werden.
The sealing rings can be ordered separately.

Beispiel:

Example:

Bestellnummer Part number	Durchmesserbereich Diameter range	möglich von-bis possible from-up to
ER 16 64 600 16 30	3,01 - 3,50	3 - 10
ER 20 64 600 20 45	4,51 - 5,00	3 - 13
ER 25 64 600 25 80	8,01 - 8,50	3 - 16

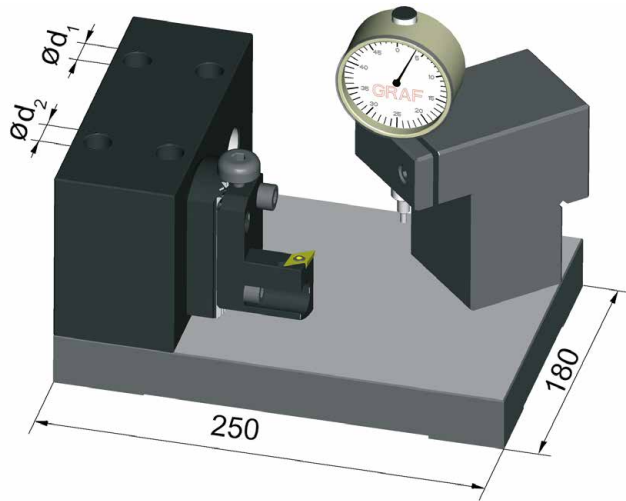
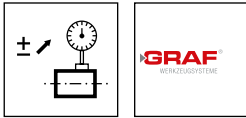

Bestellnummer Part number	d_1	d_2	Maschinentyp Machine type
HVR.40.16.22	16	22	Star
HVR.40.20.22	20	22	Star
HVR.40.20.25	20	25	Tornos
HVR.40.20.28	20	28	Hanwha
HVR.40.25.28	25	28	Hanwha
HVR.40.25.33	25	33	Hanwha
HVR.40.25.34	25	34	Hanwha
HVR.40.30.34	30	34	Maier
HVR.40.34.10	3/4"	1"	Citizen

Abmessungen in inch und mm
Dimensions in inch and mm

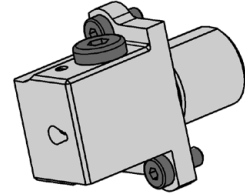
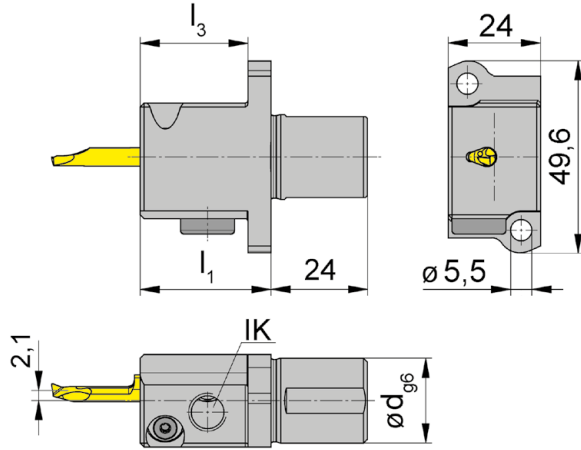
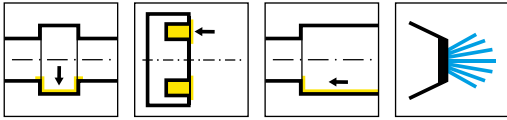

L = Linksausführung
L = left hand version

Bestellnummer Part number	d	l ₁	l ₃	HWS	HMS
LB105.A022.26.31	22	35	29	105123 • 105124 • 105125	Star

Star Langdrehautomaten:

ECAS-12/20, SB16D/E, SR-20, SR20J/JN, RS-20RII, RS-20RIII, RS-20RIV, RS-32J/JN, SW-12RIII

Swiss Type Machines Star:

ECAS-12/20, SB16D/E, SR-20, SR20J/JN, RS-20RII, RS-20RIII, RS-20RIV, RS-32J/JN, SW-12RII

Ersatzteile

Spare Parts

Klemmhalter Toolholder	TORX PLUS®-Schlüssel TORX PLUS® Wrench	Verschlusschraube Screw Plug
LB105.A022.26.31	T10PL	18.908

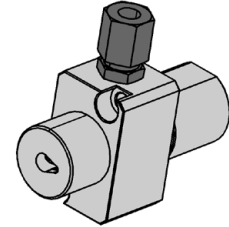
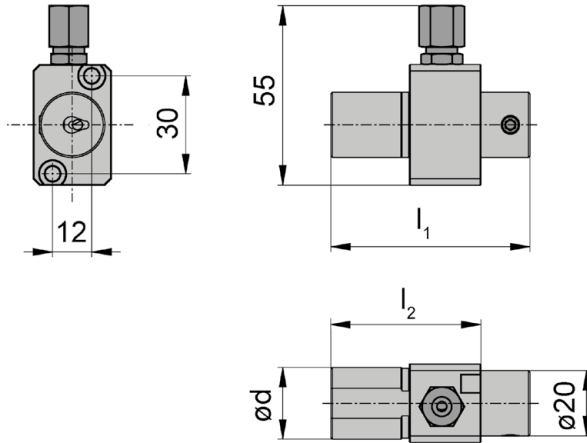
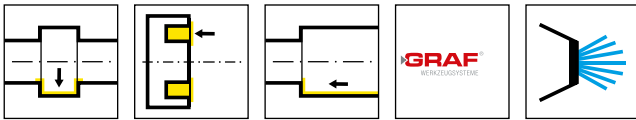

Bestellnummer Part number	d	l ₁	l ₂	HWS
RHF.N.145.H105.S1.IK	22	61	46	105123 • 105124 • 105125

Star Langdrehautomaten: SW-20
Swiss Type Machines Star: SW-20

Das Kühlmittelrohr ist nicht im Lieferumfang enthalten - bitte separat bestellen!
Coolant tube is not included - separate order required!

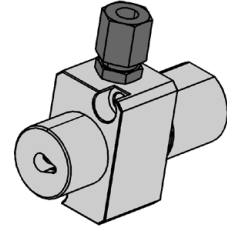
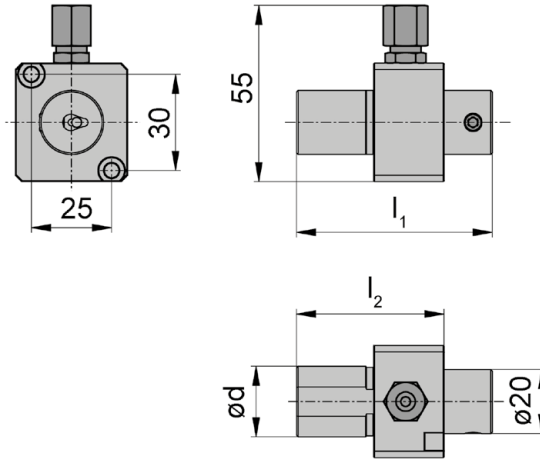
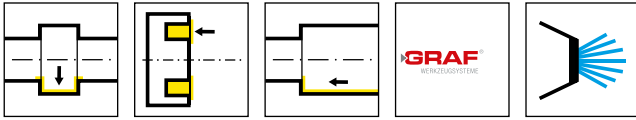

Bestellnummer Part number	d	l ₁	l ₂	HWS
RHF.N.151.H105.S2.IK	22	61	46	105123 • 105124 • 105125

Star Langdrehautomaten: SW-20
Swiss Type Machines Star: SW-20

Das Kühlmittelrohr ist nicht im Lieferumfang enthalten - bitte separat bestellen!
Coolant tube is not included - separate order required!

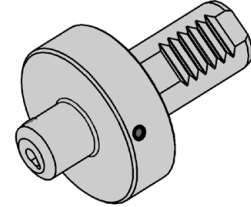
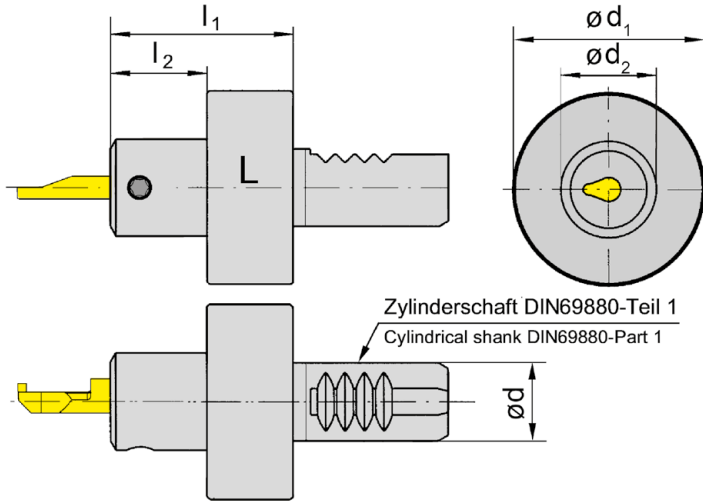
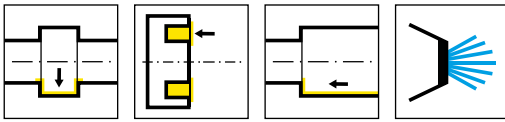

L = links wie gezeichnet
L = left hand version shown

R = rechts spiegelbildlich
R = right hand version

Bestellnummer Part number	d	l ₁	l ₂	d ₂	d ₁	HWS
VDI16.R105.20.01	16	38	20	20	40	105123 • 105124 • 105125
VDI20.R105.20.01	20	38	20	20	50	105123 • 105124 • 105125
VDI25.R105.20.01	25	38	20	20	58	105123 • 105124 • 105125
VDI30.R105.20.01	30	38	20	20	68	105123 • 105124 • 105125
VDI40.R105.20.01	40	38	20	20	83	105123 • 105124 • 105125
VDI16.L105.20.01	16	38	20	20	40	105123 • 105124 • 105125
VDI20.L105.20.01	20	38	20	20	50	105123 • 105124 • 105125
VDI25.L105.20.01	25	38	20	20	58	105123 • 105124 • 105125
VDI30.L105.20.01	30	38	20	20	68	105123 • 105124 • 105125
VDI40.L105.20.01	40	38	20	20	83	105123 • 105124 • 105125

Ersatzteile

Spare Parts

Klemmhalter Toolholder	Spannschraube Clamping Screw	TORX PLUS®-Schlüssel TORX PLUS® Wrench
VDI16...	6.075T15P	T15PQ

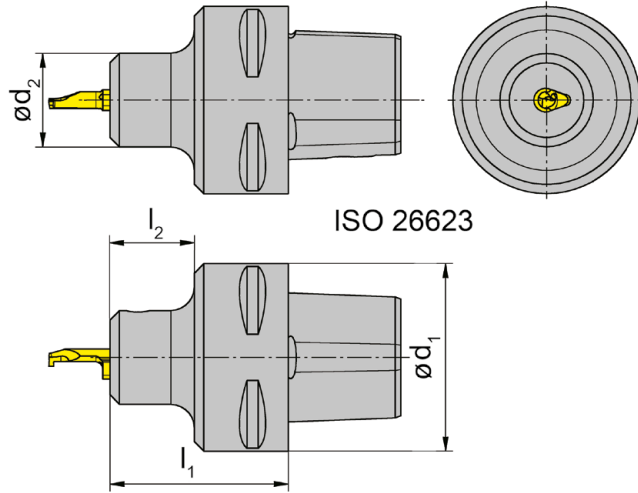
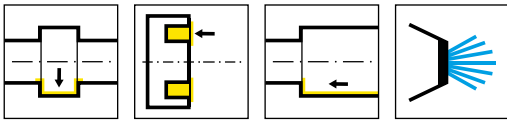

R = rechts wie gezeichnet
R = right hand version shown

L = links spiegelbildlich
L = left hand version

Bestellnummer Part number	d_1	d_2	l_1	l_2	HWS
RB105.00C3.20.1.01	32	20	30	15	105123 • 105124 • 105125
RB105.00C4.20.1.01	40	20	38	18	105123 • 105124 • 105125
RB105.00C5.20.1.01	50	20	38	18	105123 • 105124 • 105125
RB105.00C6.20.1.01	63	20	42	20	105123 • 105124 • 105125
LB105.00C3.20.1.01	32	20	30	15	105123 • 105124 • 105125
LB105.00C4.20.1.01	40	20	38	18	105123 • 105124 • 105125
LB105.00C5.20.1.01	50	20	38	18	105123 • 105124 • 105125
LB105.00C6.20.1.01	63	20	42	20	105123 • 105124 • 105125

Ersatzteile

Spare Parts

Klemmhalter Toolholder	Spannschraube Clamping Screw	TORX PLUS®-Schlüssel TORX PLUS® Wrench
R/LB105...	6.075T15P	T15PQ

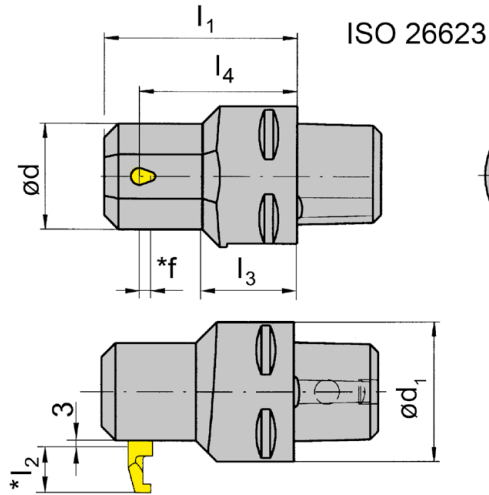
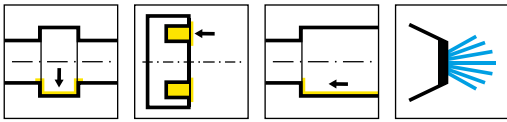

ISO 26623

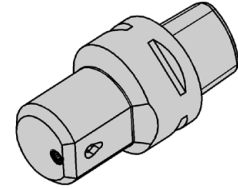

Bestellnummer Part number	d ₁	l ₃	d	l ₁	b ₁	l ₄	Maschinentyp Machine type	HWS
RB105.00C3.2.2.01	32	17	30	55	14	45	INDEX MS32	105123 • 105124 • 105125
RB105.00C3.2.2.02	32	15	36	55	18	45	INDEX MS32	105123 • 105124 • 105125
RB105.00C4.2.2.01	40	26	30	55	14	45	INDEX MS52	105123 • 105124 • 105125
RB105.00C4.2.2.02	40	22	36	55	18	45	INDEX MS52	105123 • 105124 • 105125

f, l₂ siehe Schneidplatte Typ 105
f, l₂ see inserts type 105

Ersatzteile
Spare Parts

Klemmhalter Toolholder	Spannschraube Clamping Screw	TORX PLUS®-Schlüssel TORX PLUS® Wrench
RB105...	6.075T15P	T15PQ

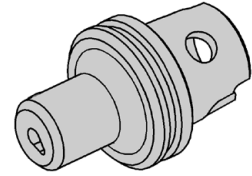
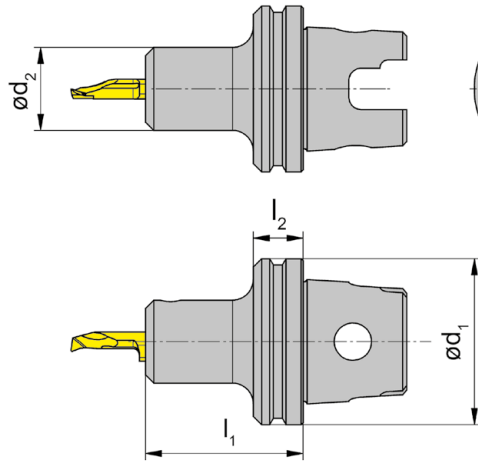
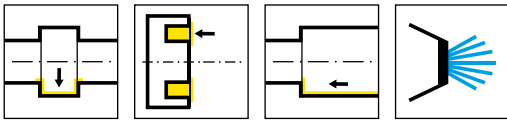

R = rechts wie gezeichnet
R = right hand version shown

L = links spiegelbildlich
L = left hand version

Bestellnummer Part number	d_1	d_2	l_1	l_2	HWS
RB105.TS40.20.1.01	40	20	38	26	105123 • 105124 • 105125
LB105.TS40.20.1.01	40	20	38	26	105123 • 105124 • 105125

Ersatzteile

Spare Parts

Klemmhalter Toolholder	Spannschraube Clamping Screw	TORX PLUS®-Schlüssel TORX PLUS® Wrench
R/LB105.TS40.20.1.01	6.075T15P	T15PQ

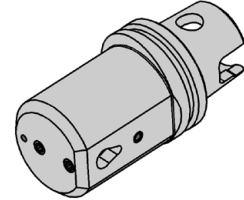
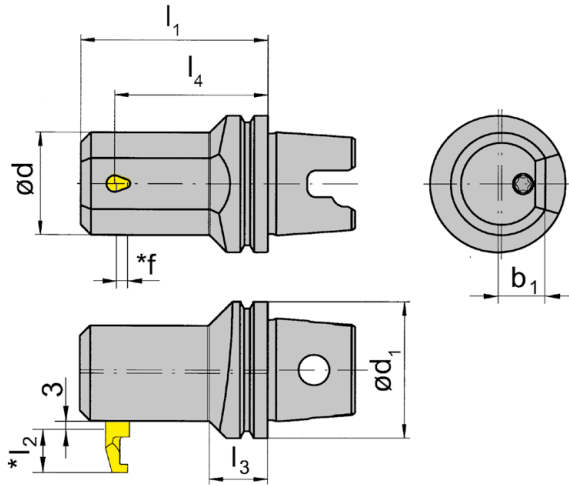
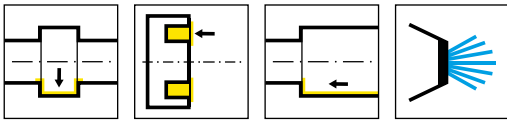

R = rechts wie gezeichnet
R = right hand version shown

L = links spiegelbildlich
L = left hand version

Bestellnummer Part number	d ₁	l ₃	d	l ₁	b ₁	l ₄	HWS
RB105.TS40.2.2.01	40	17	30	55	14	45	105123 • 105124 • 105125
RB105.TS40.2.2.02	40	14	36	55	18	45	105123 • 105124 • 105125
RB105.TS50.2.2.01	50	26	30	55	14	45	105123 • 105124 • 105125
RB105.TS50.2.2.02	50	22	36	55	18	45	105223 • 105224 • 105225

Ersatzteile
Spare Parts

Klemmhalter Toolholder	Spannschraube Clamping Screw	TORX PLUS®-Schlüssel TORX PLUS® Wrench
RB105...	6.075T15P	T15PQ

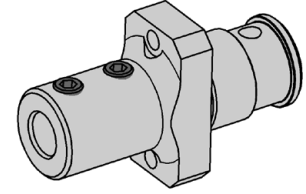
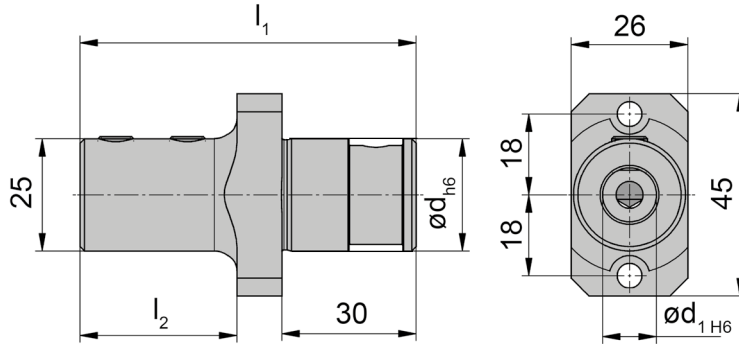
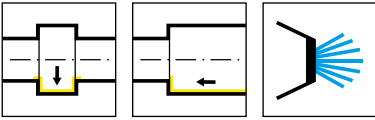

Bestellnummer Part number	d	l_1	d_1	l_2	Maschinentyp Machine type
001.C025.12.30IK	25	75	12	35	Citizen L20X/

Ersatzteile

Spare Parts

Bohrstangen-Aufnahme Adaptor for boring bars	Spannschraube Clamping Screw
001.C025.12.30IK	8.075.1835

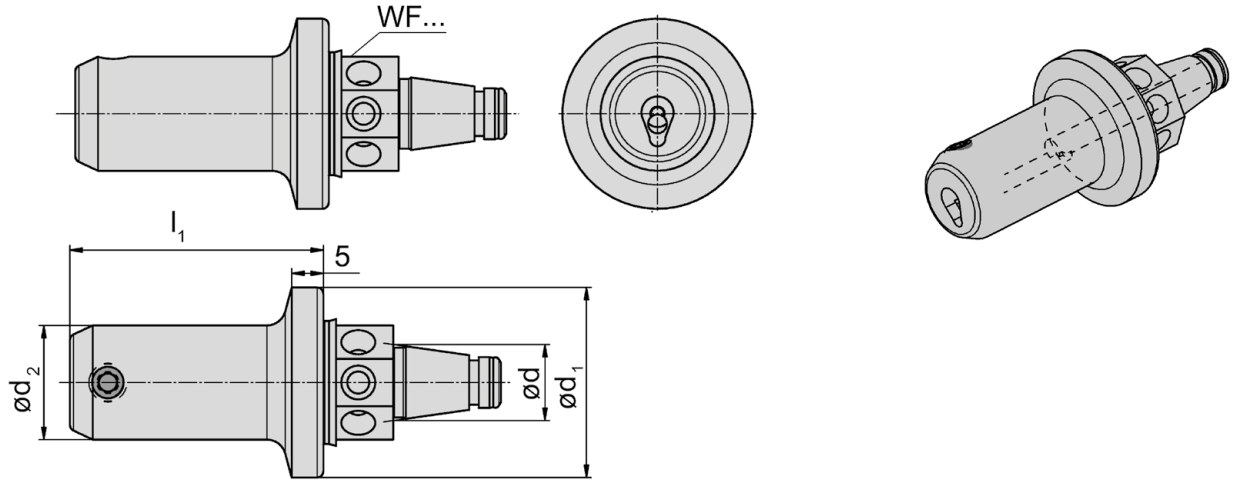
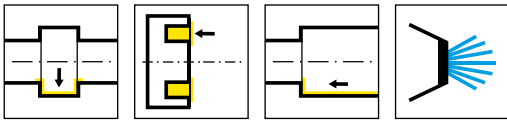

Bestellnummer Part number	d ₁	l ₁	d	d ₂	HWS	HMS
WFB.2HO.105	30	40	12	18	105123 • 105124 • 105125	WFB
WFB.2HO.105.055	30	55	12	18	105123 • 105124 • 105125	WFB
WFB.3HO.105	50	40	20	18	105123 • 105124 • 105125	WFB
WFB.3HO.105.055	50	55	20	18	105123 • 105124 • 105125	WFB

Ersatzteile

Spare Parts

Klemmhalter Toolholder	Spannschraube Clamping Screw	TORX PLUS®-Schlüssel TORX PLUS® Wrench
WFB.2HO.10...	6.075T15P	T15PQ
WFB.3HO.10...		

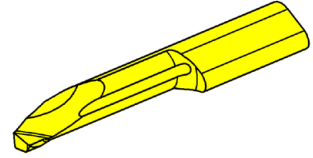
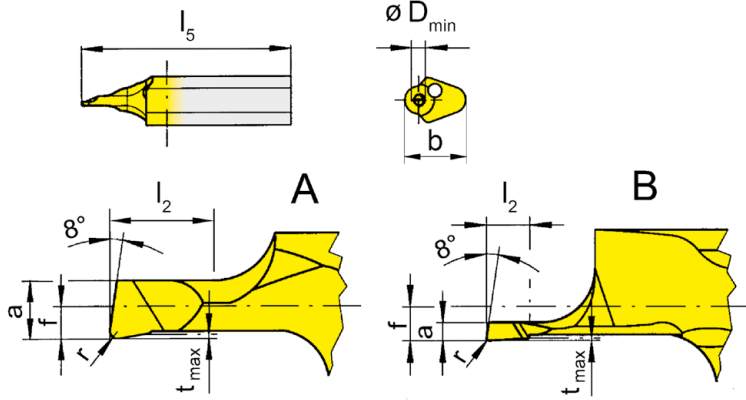
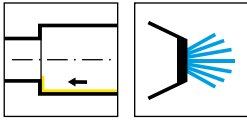

R = rechts wie gezeichnet
R = right hand version shown

L = links spiegelbildlich
L = left hand version

▲ ab Lager
on stock

HM-Sorten
Carbide grades
Δ 4 Wochen
4 weeks

Bestellnummer Part number	r	f	a	b	l ₂	l ₅	t _{max}	D _{min}	Form	HIS	MG12	EG35
R105.1802.0.02	0,02	1	0,17	5,9	1	23	0,02	0,2	B	105123	▲	Δ
R105.1802.0.03	0,02	1	0,25	5,9	1	23	0,02	0,3	B	105123	▲	Δ
R105.1802.0.05	0,05	1	0,4	5,9	2	23	0,05	0,5	B	105123	▲	▲
R105.1803.0.07	0,05	0,3	0,6	5,9	2	23	0,05	0,7	A	105123	▲	▲
L105.1802.0.02	0,02	1	0,17	5,9	1	23	0,02	0,2	B	105123	Δ	Δ
L105.1802.0.03	0,02	1	0,25	5,9	1	23	0,02	0,3	B	105123	Δ	Δ
L105.1802.0.05	0,05	1	0,4	5,9	2	23	0,05	0,5	B	105123	▲	Δ
L105.1803.0.07	0,05	0,3	0,6	5,9	2	23	0,05	0,7	A	105123	▲	Δ
											P	o ●
											M	- ●
											K	- o
											N	- -
											S	- -
											H	- -

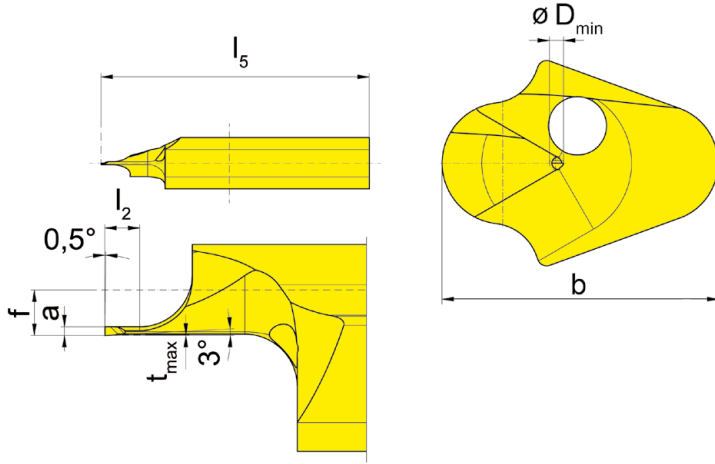
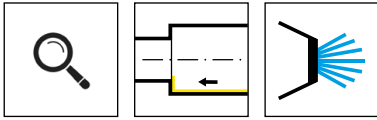

R = rechts wie gezeichnet
R = right hand version shown

▲ ab Lager
on stock

HM-Sorten
Carbide grades
Δ 4 Wochen
4 weeks

Bestellnummer Part number	f	a	b	l_2	l_5	t_{max}	D_{min}	HIS	MG12	ES15	
R105.9013.000.0.02	1,3	0,17	5,9	1	23	0,015	0,2	105123		Δ	
R105.9013.000.0.03	1,3	0,25	5,9	1	23	0,015	0,3	105123		Δ	
R105.9013.000.0.05	1,3	0,4	5,9	2	23	0,02	0,5	105123	Δ	Δ	
R105.9013.000.0.07	1,3	0,6	5,9	2	23	0,02	0,7	105123		▲	
									P	o	●
									M	-	●
									K	-	o
									N	-	-
									S	-	-
									H	-	-

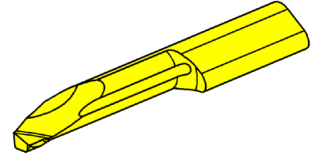
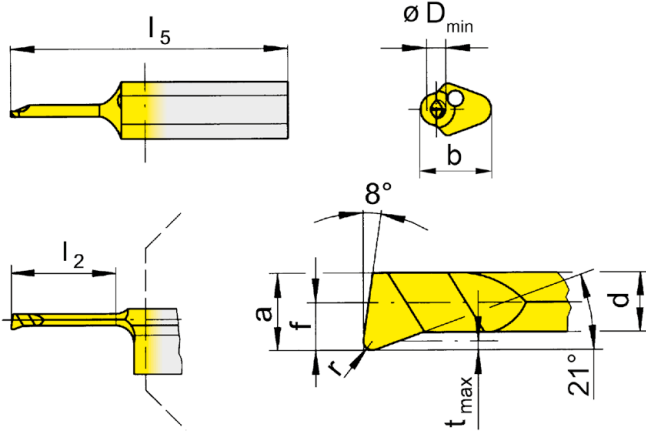
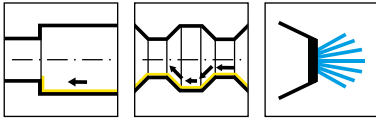

R = rechts wie gezeichnet
R = right hand version shown

L = links spiegelbildlich
L = left hand version

HM-Sorten
Carbide grades
▲ ab Lager
on stock
Δ 4 Wochen
4 weeks

Bestellnummer Part number	r	f	a	d	b	l ₂	l ₅	t _{max}	D _{min}	HIS	MG12	EG35	TF45	TH35	TI25	TN35
R105.1805.005.0.1	0,05	0,5	0,9	0,65	5,9	4	25	0,1	1	105123		▲	▲			
R105.1805.005.1.1	0,05	0,5	0,9	0,65	5,9	6	25	0,1	1	105123		▲	▲			
R105.1805.005.2.1	0,05	0,5	0,9	0,65	5,9	8	25	0,1	1	105123		Δ	▲	Δ		
R105.1805.0.1	0,1	0,5	0,9	0,65	5,9	4	25	0,1	1	105123	▲	▲	Δ		▲	▲
R105.1805.1.1	0,1	0,5	0,9	0,65	5,9	6	25	0,1	1	105123	Δ	▲			▲	▲
R105.1805.2.1	0,1	0,5	0,9	0,65	5,9	8	25	0,1	1	105123		▲			▲	▲
R105.1813.005.0.15	0,05	1,3	1,4	1,1	5,9	6	25	0,15	1,5	105123		▲	▲	Δ		
R105.1813.005.1.15	0,05	1,3	1,4	1,1	5,9	9	25	0,15	1,5	105123		▲	▲	Δ		
R105.1813.005.2.15	0,05	1,3	1,4	1,1	5,9	12	30	0,15	1,5	105123		▲	▲	Δ		
R105.1813.01.0.15	0,1	1,3	1,4	1,1	5,9	6	25	0,15	1,5	105123		▲		▲	▲	
R105.1813.01.1.15	0,1	1,3	1,4	1,1	5,9	9	25	0,15	1,5	105123		▲		▲	▲	
R105.1813.01.2.15	0,1	1,3	1,4	1,1	5,9	12	30	0,15	1,5	105123		Δ		▲	▲	
L105.1805.005.0.1	0,05	0,5	0,9	0,65	5,9	4	25	0,1	1	105123		Δ	▲			
L105.1805.005.1.1	0,05	0,5	0,9	0,65	5,9	6	25	0,1	1	105123		Δ	▲			
L105.1805.005.2.1	0,05	0,5	0,9	0,65	5,9	8	25	0,1	1	105123			▲			
L105.1805.0.1	0,1	0,5	0,9	0,65	5,9	4	25	0,1	1	105123		▲			▲	▲
L105.1805.1.1	0,1	0,5	0,9	0,65	5,9	6	25	0,1	1	105123		▲			▲	▲
L105.1805.2.1	0,1	0,5	0,9	0,65	5,9	8	25	0,1	1	105123		Δ			Δ	▲
L105.1813.005.0.15	0,05	1,3	1,4	1,1	5,9	6	25	0,15	1,5	105123		Δ	▲	Δ		
L105.1813.005.1.15	0,05	1,3	1,4	1,1	5,9	9	25	0,15	1,5	105123		Δ	▲			
L105.1813.005.2.15	0,05	1,3	1,4	1,1	5,9	12	30	0,15	1,5	105123		Δ	Δ			
L105.1813.01.0.15	0,1	1,3	1,4	1,1	5,9	6	25	0,15	1,5	105123		Δ		▲	▲	
L105.1813.01.1.15	0,1	1,3	1,4	1,1	5,9	9	25	0,15	1,5	105123		Δ		▲	▲	
L105.1813.01.2.15	0,1	1,3	1,4	1,1	5,9	12	30	0,15	1,5	105123		Δ		▲	▲	
											P	o	•	•	•	•
											M	-	•	•	•	•
											K	-	o	•	•	•
											N	-	-	•	•	•
											S	-	-	•	•	•
											H	-	-	-	-	-

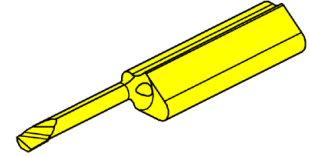
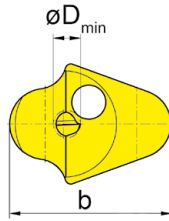
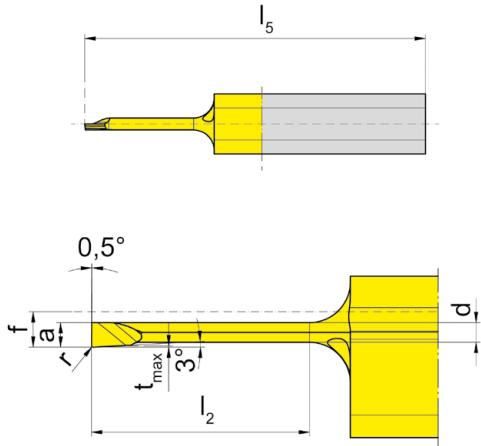
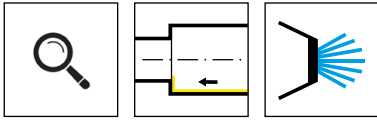

R = rechts wie gezeichnet
R = right hand version shown

HM-Sorten
Carbide grades
▲ ab Lager
on stock
Δ 4 Wochen
4 weeks

Bestellnummer Part number	r	f	a	d	b	l ₂	l ₅	t _{max}	D _{min}	HIS	ES15
R105.9013.000.0.1	-	1,3	0,9	0,72	5,9	4	25	0,05	1	105123	▲
R105.9013.000.2.1	-	1,3	0,9	0,72	5,9	8	25	0,05	1	105123	Δ
R105.9013.003.0.1	0,03	1,3	0,9	0,72	5,9	4	25	0,05	1	105123	Δ
R105.9013.003.2.1	0,03	1,3	0,9	0,72	5,9	8	25	0,05	1	105123	Δ
R105.9013.000.0.15	-	1,3	1,4	1,15	5,9	6	25	0,1	1,5	105123	▲
R105.9013.000.1.15	-	1,3	1,4	1,15	5,9	9	25	0,1	1,5	105123	Δ
R105.9013.003.0.15	0,03	1,3	1,4	1,15	5,9	6	25	0,1	1,5	105123	▲
R105.9013.003.1.15	0,03	1,3	1,4	1,15	5,9	9	25	0,1	1,5	105123	Δ
											P ●
											M ●
											K ○
											N -
											S -
											H -

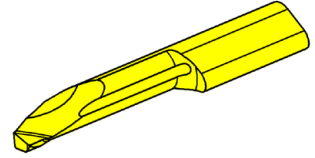
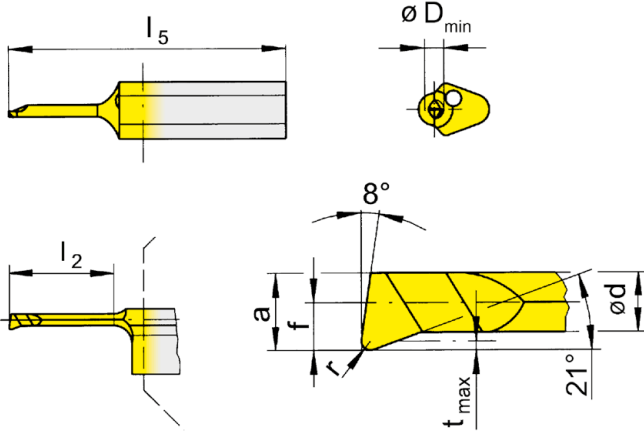
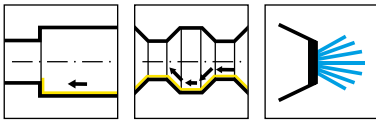

R = rechts wie gezeichnet
R = right hand version shown

L = links spiegelbildlich
L = left hand version

HM-Sorten
Carbide grades
▲ ab Lager
on stock
Δ 4 Wochen
4 weeks

Bestellnummer Part number	r	f	a	d	b	l ₂	l ₅	t _{max}	D _{min}	HIS	HM-Sorten					
											MG12	EG35	TF45	TH35	TI25	TN35
R105.1809.005.0.2	0,05	1	1,9	1,6	5,9	6	25	0,15	2	105123		▲	▲	▲	▲	▲
R105.1809.005.1.2	0,05	1	1,9	1,6	5,9	9	25	0,15	2	105123	Δ	▲	▲	▲	▲	▲
R105.1809.005.2.2	0,05	1	1,9	1,6	5,9	12	30	0,15	2	105123		▲	▲	▲	▲	▲
R105.1809.01.0.2	0,1	1	1,9	1,6	5,9	6	25	0,15	2	105123		Δ		▲	▲	
R105.1809.01.1.2	0,1	1	1,9	1,6	5,9	9	25	0,15	2	105123		▲	Δ	▲	▲	
R105.1809.01.2.2	0,1	1	1,9	1,6	5,9	12	30	0,15	2	105123		Δ		▲	▲	
R105.1809.0.2	0,15	1	1,9	1,6	5,9	6	25	0,15	2	105123	▲	▲		▲	▲	▲
R105.1809.1.2	0,15	1	1,9	1,6	5,9	9	25	0,15	2	105123	▲	▲		▲	▲	▲
R105.1809.2.2	0,15	1	1,9	1,6	5,9	12	30	0,15	2	105123	▲	▲		▲	▲	▲
R105.1813.005.0.25	0,05	1,3	2,3	1,95	5,9	6	25	0,15	2,5	105123		▲	Δ	▲		
R105.1813.005.1.25	0,05	1,3	2,3	1,95	5,9	9	25	0,15	2,5	105123		▲	▲	▲		
R105.1813.005.2.25	0,05	1,3	2,3	1,95	5,9	12	30	0,15	2,5	105123		Δ	▲	▲		
R105.1813.005.3.25	0,05	1,3	2,3	1,95	5,9	16	35	0,15	2,5	105123		▲	▲	▲		
L105.1809.005.0.2	0,05	1	1,9	1,6	5,9	6	25	0,15	2	105123		Δ	▲	▲		
L105.1809.005.1.2	0,05	1	1,9	1,6	5,9	9	25	0,15	2	105123		Δ	▲	▲		
L105.1809.005.2.2	0,05	1	1,9	1,6	5,9	12	30	0,15	2	105123		Δ	▲			
L105.1809.01.0.2	0,1	1	1,9	1,6	5,9	6	25	0,15	2	105123		Δ		▲	▲	
L105.1809.01.1.2	0,1	1	1,9	1,6	5,9	9	25	0,15	2	105123		Δ		▲	▲	Δ
L105.1809.01.2.2	0,1	1	1,9	1,6	5,9	12	30	0,15	2	105123		Δ		▲	▲	
L105.1809.0.2	0,15	1	1,9	1,6	5,9	6	25	0,15	2	105123	Δ	▲		▲	▲	▲
L105.1809.1.2	0,15	1	1,9	1,6	5,9	9	25	0,15	2	105123	Δ	▲		▲	▲	▲
L105.1809.2.2	0,15	1	1,9	1,6	5,9	12	30	0,15	2	105123	Δ	▲		▲	▲	▲
L105.1813.005.0.25	0,05	1,3	2,3	1,95	5,9	6	25	0,15	2,5	105123		Δ		▲		
L105.1813.005.1.25	0,05	1,3	2,3	1,95	5,9	9	25	0,15	2,5	105123		Δ	▲			
L105.1813.005.2.25	0,05	1,3	2,3	1,95	5,9	12	30	0,15	2,5	105123		Δ	▲	▲		
L105.1813.005.3.25	0,05	1,3	2,3	1,95	5,9	16	35	0,15	2,5	105123		Δ	▲	▲		
P	o	•	•	•	•	•	•	•	•	•						
M	-	•	•	•	•	•	•	•	•	•						
K	-	o	•	•	•	•	•	•	•	•						
N	-	-	•	•	•	•	•	•	•	•						
S	-	-	•	•	•	•	•	•	•	•						
H	-	-	-	-	-	-	-	-	-	-						

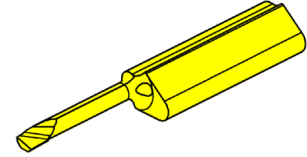
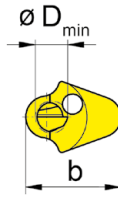
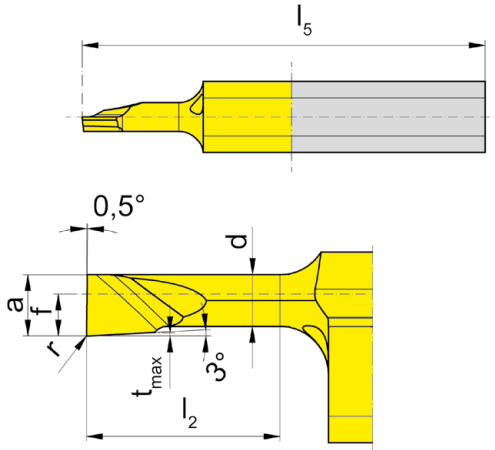
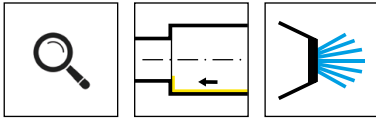

R = rechts wie gezeichnet
R = right hand version shown

▲ ab Lager
on stock

HM-Sorten
Carbide grades
Δ 4 Wochen
4 weeks

Bestellnummer Part number	r	f	a	d	b	l_2	l_5	t_{max}	D_{min}	HIS	MG12	ES15
R105.9013.000.0.2	-	1,3	1,9	1,6	5,9	6	25	0,1	2	105123		▲
R105.9013.000.2.2	-	1,3	1,9	1,6	5,9	12	30	0,1	2	105123		Δ
R105.9013.003.0.2	0,03	1,3	1,9	1,6	5,9	6	25	0,1	2	105123		▲
R105.9013.003.2.2	0,03	1,3	1,9	1,6	5,9	12	30	0,1	2	105123		Δ
R105.9013.000.0.25	-	1,3	2,3	2	5,9	6	25	0,1	2,5	105123		Δ
R105.9013.000.2.25	-	1,3	2,3	2	5,9	12	30	0,1	2,5	105123	Δ	Δ
R105.9013.000.3.25	-	1,3	2,3	2	5,9	16	35	0,1	2,5	105123		Δ
R105.9013.003.0.25	0,03	1,3	2,3	2	5,9	6	25	0,1	2,5	105123		▲
R105.9013.003.2.25	0,03	1,3	2,3	2	5,9	12	30	0,1	2,5	105123	Δ	Δ
R105.9013.003.3.25	0,03	1,3	2,3	2	5,9	16	35	0,1	2,5	105123		Δ
											P	o ●
											M	- ●
											K	- o
											N	- -
											S	- -
											H	- -

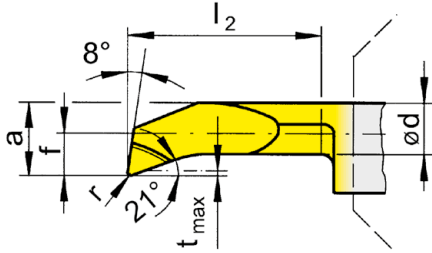
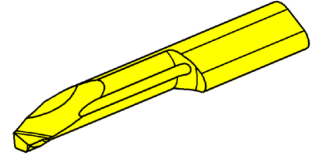
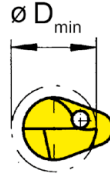
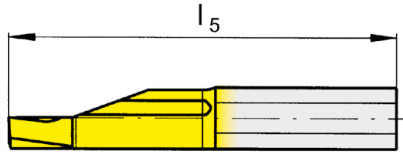
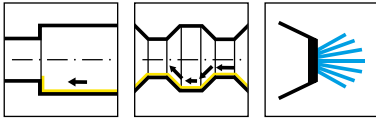

R = rechts wie gezeichnet
R = right hand version shown

L = links spiegelbildlich
L = left hand version

▲ ab Lager
on stock

HM-Sorten
Carbide grades
Δ 4 Wochen
4 weeks

Bestellnummer Part number	r	f	a	d	b	l ₂	l ₅	t _{max}	D _{min}	HIS	MG12	EG35	TF45	TH35	TI25	TN35
R105.1813.005.1.3	0,05	1,3	2,6	2,3	5,9	10	25	0,15	3	105123		▲	▲	Δ	Δ	Δ
R105.1813.005.2.3	0,05	1,3	2,6	2,3	5,9	15	30	0,15	3	105123		Δ	▲		Δ	Δ
R105.1813.005.3.3	0,05	1,3	2,6	2,3	5,9	20	35	0,15	3	105123		▲	▲		Δ	
R105.1813.01.1.3	0,1	1,3	2,6	2,3	5,9	10	25	0,15	3	105123		▲		▲	▲	
R105.1813.01.2.3	0,1	1,3	2,6	2,3	5,9	15	30	0,15	3	105123		▲		▲	▲	
R105.1813.01.3.3	0,1	1,3	2,6	2,3	5,9	20	35	0,15	3	105123		▲		▲	▲	
R105.1813.1.3	0,2	1,3	2,6	2,3	5,9	10	25	0,15	3	105123	▲	▲	Δ	▲	▲	▲
R105.1813.2.3	0,2	1,3	2,6	2,3	5,9	15	30	0,15	3	105123	▲	▲	Δ	▲	▲	▲
R105.1813.3.3	0,2	1,3	2,6	2,3	5,9	20	35	0,15	3	105123	▲	▲		▲	▲	▲
L105.1813.005.1.3	0,05	1,3	2,6	2,3	5,9	10	25	0,15	3	105123			Δ	▲		
L105.1813.005.2.3	0,05	1,3	2,6	2,3	5,9	15	30	0,15	3	105123			Δ	▲		
L105.1813.005.3.3	0,05	1,3	2,6	2,3	5,9	20	35	0,15	3	105123			Δ	▲		
L105.1813.01.1.3	0,1	1,3	2,6	2,3	5,9	10	25	0,15	3	105123			Δ		▲	▲
L105.1813.01.2.3	0,1	1,3	2,6	2,3	5,9	15	30	0,15	3	105123			Δ		▲	▲
L105.1813.01.3.3	0,1	1,3	2,6	2,3	5,9	20	35	0,15	3	105123			Δ		▲	▲
L105.1813.1.3	0,2	1,3	2,6	2,3	5,9	10	25	0,15	3	105123	▲	▲		▲	▲	▲
L105.1813.2.3	0,2	1,3	2,6	2,3	5,9	15	30	0,15	3	105123	▲	▲		▲	▲	▲
L105.1813.3.3	0,2	1,3	2,6	2,3	5,9	20	35	0,15	3	105123	▲	▲		▲	▲	▲
P											○	●	●	●	●	●
M											-	●	●	●	●	●
K											-	○	●	●	●	●
N											-	-	●	●	●	●
S											-	-	●	●	●	●
H											-	-	-	-	-	-

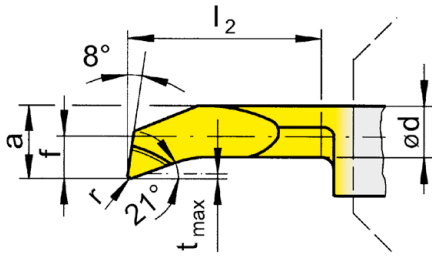
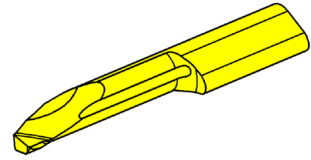
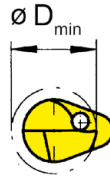
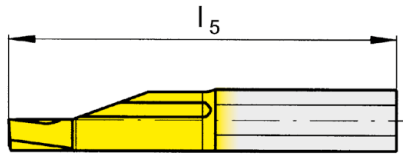
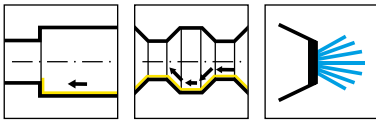

R = rechts wie gezeichnet
R = right hand version shown

L = links spiegelbildlich
L = left hand version

▲ ab Lager
on stock

HM-Sorten
Carbide grades
Δ 4 Wochen
4 weeks

Bestellnummer Part number	r	f	a	d	b	l_2	l_5	t_{max}	D_{min}	HIS	MG12	EG35	TF45	TH35	TI25	TN35
R105.1819.005.1.4	0,05	1,9	3,7	2,9	6,4	10	25	0,3	4	105124		▲	▲	Δ	Δ	
R105.1819.005.2.4	0,05	1,9	3,7	2,9	6,4	15	30	0,3	4	105124		▲	▲	▲	▲	
R105.1819.005.3.4	0,05	1,9	3,7	2,9	6,4	20	35	0,3	4	105124		▲	▲	Δ		
R105.1819.1.4	0,2	1,9	3,7	2,9	6,4	10	25	0,3	4	105124	▲	▲		▲	▲	▲
R105.1819.2.4	0,2	1,9	3,7	2,9	6,4	15	30	0,3	4	105124	▲	▲	Δ	▲	▲	▲
R105.1819.3.4	0,2	1,9	3,7	2,9	6,4	20	35	0,3	4	105124	▲	▲	Δ	▲	▲	▲
L105.1819.005.1.4	0,05	1,9	3,7	2,9	6,4	10	25	0,3	4	105124			Δ	▲	Δ	
L105.1819.005.2.4	0,05	1,9	3,7	2,9	6,4	15	30	0,3	4	105124			Δ	▲		
L105.1819.005.3.4	0,05	1,9	3,7	2,9	6,4	20	35	0,3	4	105124			Δ	▲	Δ	
L105.1819.1.4	0,2	1,9	3,7	2,9	6,4	10	25	0,3	4	105124	▲	▲		▲	▲	▲
L105.1819.2.4	0,2	1,9	3,7	2,9	6,4	15	30	0,3	4	105124	▲	▲		▲	▲	▲
L105.1819.3.4	0,2	1,9	3,7	2,9	6,4	20	35	0,3	4	105124	▲	▲		▲	▲	▲
P	o	•	•	•	•	•	•	•	•							
M	-	•	•	•	•	•	•	•	•							
K	-	o	•	•	•	•	•	•	•							
N	-	-	•	•	•	•	•	•	•							
S	-	-	•	•	•	•	•	•	•							
H	-	-	-	-	-	-	-	-	-							

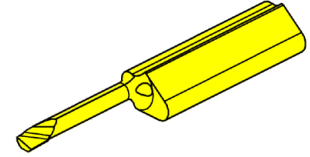
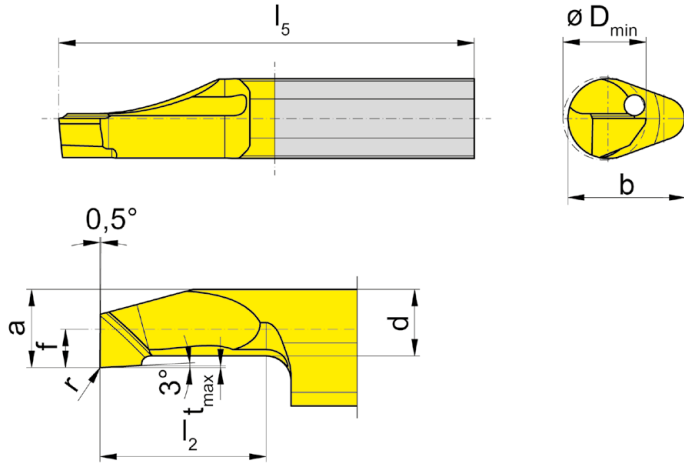
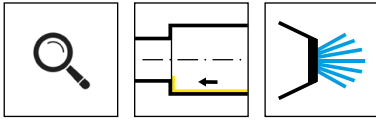

R = rechts wie gezeichnet
R = right hand version shown

HM-Sorten
Carbide grades
▲ ab Lager
on stock
Δ 4 Wochen
4 weeks

Bestellnummer Part number	r	f	a	d	b	l_2	l_5	t_{max}	D_{min}	HIS	ES15
R105.9013.000.1.3	-	1,3	2,6	2,3	5,9	10	25	0,1	3	105123	▲
R105.9013.000.3.3	-	1,3	2,6	2,3	5,9	20	35	0,1	3	105123	Δ
R105.9013.003.1.3	0,03	1,3	2,6	2,3	5,9	10	25	0,1	3	105123	▲
R105.9013.003.3.3	0,03	1,3	2,6	2,3	5,9	20	35	0,1	3	105123	▲
R105.9019.000.1.4	-	1,9	3,7	3,2	6,4	10	25	0,1	4	105124	Δ
R105.9019.000.3.4	-	1,9	3,7	3,2	6,4	20	35	0,1	4	105124	Δ
R105.9019.003.1.4	0,03	1,9	3,7	3,2	6,4	10	25	0,1	4	105124	Δ
R105.9019.003.3.4	0,03	1,9	3,7	3,2	6,4	20	35	0,1	4	105124	Δ
											P ●
											M ●
											K ○
											N -
											S -
											H -

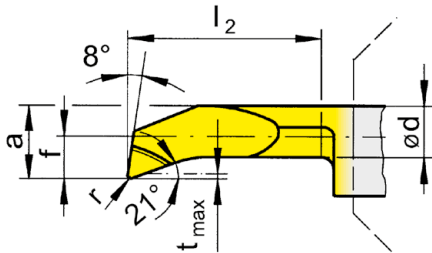
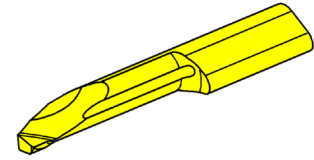
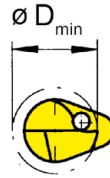
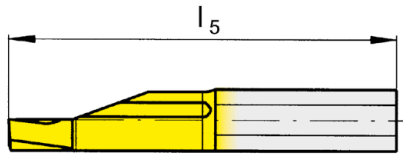
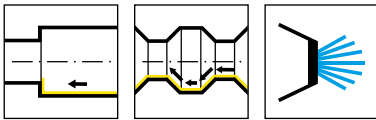

R = rechts wie gezeichnet
R = right hand version shown

L = links spiegelbildlich
L = left hand version

▲ ab Lager
on stock

HM-Sorten
Carbide grades
Δ 4 Wochen
4 weeks

Bestellnummer Part number	r	f	a	d	b	l ₂	l ₅	t _{max}	D _{min}	HIS	MG12	EG35	TF45	TH35	TI25	TN35
R105.1823.005.1.5	0,05	2,3	4,7	4	7	10	25	0,5	5	105125	Δ	▲	▲	Δ		
R105.1823.005.2.5	0,05	2,3	4,7	4	7	15	30	0,5	5	105125		▲	▲	Δ		Δ
R105.1823.005.3.5	0,05	2,3	4,7	4	7	20	35	0,5	5	105125		▲	▲	Δ		Δ
R105.1823.005.4.5	0,05	2,3	4,7	4	7	25	40	0,5	5	105125		▲	▲			Δ
R105.1823.005.5.5	0,05	2,3	4,7	4	7	30	45	0,5	5	105125		Δ	▲	Δ		
R105.1823.1.5	0,2	2,3	4,7	4	7	10	25	0,5	5	105125	▲	▲	Δ	▲	▲	▲
R105.1823.2.5	0,2	2,3	4,7	4	7	15	30	0,5	5	105125	▲	▲		▲	▲	▲
R105.1823.3.5	0,2	2,3	4,7	4	7	20	35	0,5	5	105125	▲	▲	Δ	▲	▲	▲
R105.1823.4.5	0,2	2,3	4,7	4	7	25	40	0,5	5	105125	▲	▲		▲	▲	▲
R105.1823.5.5	0,2	2,3	4,7	4	7	30	45	0,5	5	105125	▲	▲		▲	▲	▲
L105.1823.005.1.5	0,05	2,3	4,7	4	7	10	25	0,5	5	105125		Δ	▲		Δ	
L105.1823.005.2.5	0,05	2,3	4,7	4	7	15	30	0,5	5	105125		Δ	▲			
L105.1823.005.3.5	0,05	2,3	4,7	4	7	20	35	0,5	5	105125		Δ	▲			
L105.1823.005.4.5	0,05	2,3	4,7	4	7	25	40	0,5	5	105125		▲	▲			
L105.1823.005.5.5	0,05	2,3	4,7	4	7	30	45	0,5	5	105125		Δ	▲			
L105.1823.1.5	0,2	2,3	4,7	4	7	10	25	0,5	5	105125	▲	▲		▲	▲	▲
L105.1823.2.5	0,2	2,3	4,7	4	7	15	30	0,5	5	105125	▲	▲		▲	▲	▲
L105.1823.3.5	0,2	2,3	4,7	4	7	20	35	0,5	5	105125	▲	▲		▲	▲	▲
L105.1823.4.5	0,2	2,3	4,7	4	7	25	40	0,5	5	105125	▲	▲		▲	▲	▲
L105.1823.5.5	0,2	2,3	4,7	4	7	30	45	0,5	5	105125	▲	▲		▲	▲	▲
P	O	●	●	●	●	●	●	●	●	●	●	●	●	●	●	●
M	-	●	●	●	●	●	●	●	●	●	●	●	●	●	●	●
K	-	O	●	●	●	●	●	●	●	●	●	●	●	●	●	●
N	-	-	●	●	●	●	●	●	●	●	●	●	●	●	●	●
S	-	-	●	●	●	●	●	●	●	●	●	●	●	●	●	●
H	-	-	-	-	-	-	-	-	-	-	-	-	-	-	-	-

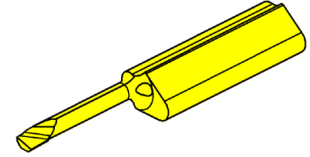
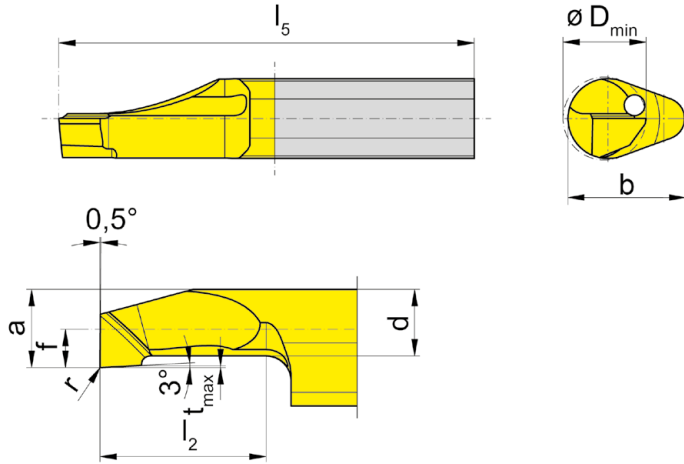
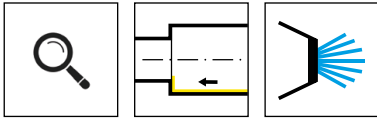

R = rechts wie gezeichnet
R = right hand version shown

HM-Sorten
Carbide grades
▲ ab Lager
on stock
Δ 4 Wochen
4 weeks

Bestellnummer Part number	r	f	a	d	b	l_2	l_5	t_{max}	D_{min}	HIS	ES15
R105.9023.000.1.5	-	2,3	4,7	4	7	10	25	0,1	5	105125	Δ
R105.9023.000.3.5	-	2,3	4,7	4	7	20	35	0,1	5	105125	Δ
R105.9023.000.5.5	-	2,3	4,7	4	7	30	45	0,1	5	105125	Δ
R105.9023.003.1.5	0,03	2,3	4,7	4	7	10	25	0,1	5	105125	Δ
R105.9023.003.3.5	0,03	2,3	4,7	4	7	20	35	0,1	5	105125	Δ
R105.9023.003.5.5	0,03	2,3	4,7	4	7	30	45	0,1	5	105125	Δ
											P ●
											M ●
											K ○
											N -
											S -
											H -

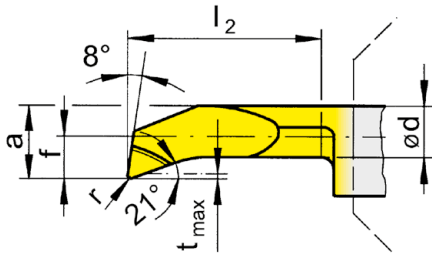
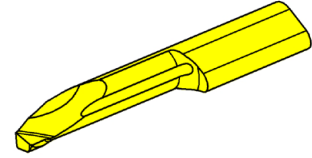
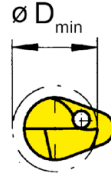
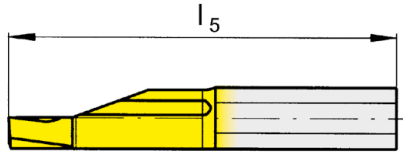
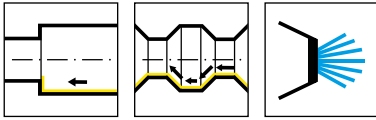

R = rechts wie gezeichnet
R = right hand version shown

L = links spiegelbildlich
L = left hand version

▲ ab Lager
on stock

HM-Sorten
Carbide grades
Δ 4 Wochen
4 weeks

Bestellnummer Part number	r	f	a	d	b	l ₂	l ₅	t _{max}	D _{min}	HIS	MG12	EG35	TF45	TH35	TI25	TN35
R105.1833.005.2.6	0,05	3,3	5,7	4,7	7	15	30	0,5	6	105125		▲	▲			
R105.1833.005.3.6	0,05	3,3	5,7	4,7	7	20	35	0,5	6	105125		Δ	▲			
R105.1833.005.4.6	0,05	3,3	5,7	4,7	7	25	40	0,5	6	105125		Δ	▲			
R105.1833.005.5.6	0,05	3,3	5,7	4,7	7	30	45	0,5	6	105125		Δ	▲			Δ
R105.1833.2.6	0,2	3,3	5,7	4,7	7	15	30	0,5	6	105125	▲	▲		▲	▲	▲
R105.1833.3.6	0,2	3,3	5,7	4,7	7	20	35	0,5	6	105125	▲	▲	Δ	▲	▲	▲
R105.1833.4.6	0,2	3,3	5,7	4,7	7	25	40	0,5	6	105125	▲	▲		▲	▲	▲
R105.1833.5.6	0,2	3,3	5,7	4,7	7	30	45	0,5	6	105125	▲	▲		▲	▲	▲
R105.1840.005.3.7	0,05	4	6,4	5,2	7	20	35	0,5	6,8	105125		Δ	▲			
R105.1840.005.4.7	0,05	4	6,4	5,2	7	25	40	0,5	6,8	105125		Δ	▲			
R105.1840.005.5.7	0,05	4	6,4	5,2	7	30	45	0,5	6,8	105125		Δ	▲			
R105.1840.3.7	0,2	4	6,4	5,2	7	20	35	0,5	6,8	105125	▲	▲	Δ	▲	▲	▲
R105.1840.4.7	0,2	4	6,4	5,2	7	25	40	0,5	6,8	105125	▲	▲	Δ	▲	▲	▲
R105.1840.5.7	0,2	4	6,4	5,2	7	30	45	0,5	6,8	105125	▲	▲		▲	▲	▲
L105.1833.005.2.6	0,05	3,3	5,7	4,7	7	15	30	0,5	6	105125		Δ	▲	Δ		
L105.1833.005.3.6	0,05	3,3	5,7	4,7	7	20	35	0,5	6	105125		Δ	▲			
L105.1833.005.4.6	0,05	3,3	5,7	4,7	7	25	40	0,5	6	105125		Δ	Δ			
L105.1833.005.5.6	0,05	3,3	5,7	4,7	7	30	45	0,5	6	105125		Δ	Δ			
L105.1833.2.6	0,2	3,3	5,7	4,7	7	15	30	0,5	6	105125	▲	▲		▲	▲	▲
L105.1833.3.6	0,2	3,3	5,7	4,7	7	20	35	0,5	6	105125	▲	▲		▲	▲	▲
L105.1833.4.6	0,2	3,3	5,7	4,7	7	25	40	0,5	6	105125	▲	▲		▲	▲	▲
L105.1833.5.6	0,2	3,3	5,7	4,7	7	30	45	0,5	6	105125	▲	▲		▲	▲	▲
L105.1840.005.3.7	0,05	4	6,4	5,2	7	20	35	0,5	6,8	105125		Δ	▲			
L105.1840.005.4.7	0,05	4	6,4	5,2	7	25	40	0,5	6,8	105125		Δ	▲			
L105.1840.005.5.7	0,05	4	6,4	5,2	7	30	45	0,5	6,8	105125		Δ	▲			
L105.1840.3.7	0,2	4	6,4	5,2	7	20	35	0,5	6,8	105125	▲	▲		▲	▲	▲
L105.1840.4.7	0,2	4	6,4	5,2	7	25	40	0,5	6,8	105125	▲	▲		▲	▲	▲
L105.1840.5.7	0,2	4	6,4	5,2	7	30	45	0,5	6,8	105125	▲	▲		▲	▲	▲
P	o	•	•	•	•	•	•	•	•	•	•	•	•	•	•	•
M	-	•	•	•	•	•	•	•	•	•	•	•	•	•	•	•
K	-	o	•	•	•	•	•	•	•	•	•	•	•	•	•	•
N	-	-	•	•	•	•	•	•	•	•	•	•	•	•	•	•
S	-	-	•	•	•	•	•	•	•	•	•	•	•	•	•	•
H	-	-	-	-	-	-	-	-	-	-	-	-	-	-	-	-

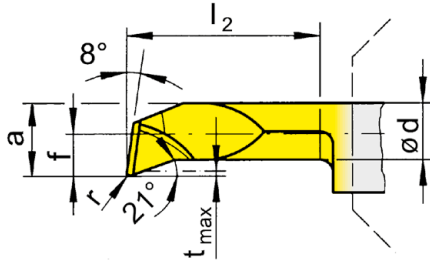
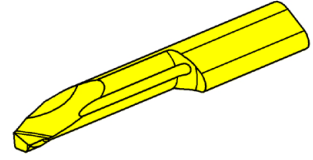
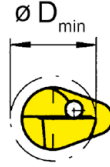
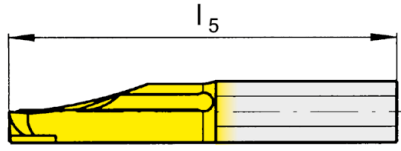
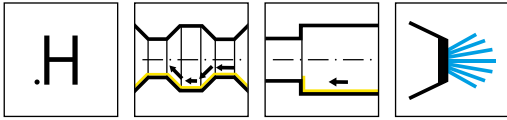

R = rechts wie gezeichnet
R = right hand version shown

L = links spiegelbildlich
L = left hand version

▲ ab Lager
on stock

HM-Sorten
Carbide grades
Δ 4 Wochen
4 weeks

Bestellnummer Part number	r	f	a	d	b	l ₂	l ₅	t _{max}	D _{min}	HIS	EG35	TF45	TH35
R105.1819.1.H.4	0,2	1,9	3,7	2,9	7	10	25	0,3	4	105125	Δ	▲	▲
R105.1819.2.H.4	0,2	1,9	3,7	2,9	7	15	30	0,3	4	105125	▲	▲	▲
R105.1819.3.H.4	0,2	1,9	3,7	2,9	7	20	35	0,3	4	105125	Δ	▲	▲
R105.1823.1.H.5	0,2	2,3	4,7	4	7	10	25	0,5	5	105125	▲	▲	▲
R105.1823.2.H.5	0,2	2,3	4,7	4	7	15	30	0,5	5	105125	▲	▲	▲
R105.1823.3.H.5	0,2	2,3	4,7	4	7	20	35	0,5	5	105125	▲	▲	▲
R105.1823.4.H.5	0,2	2,3	4,7	4	7	25	40	0,5	5	105125	▲	▲	▲
R105.1823.5.H.5	0,2	2,3	4,7	4	7	30	45	0,5	5	105125	Δ	▲	▲
L105.1819.1.H.4	0,2	1,9	3,7	2,9	7	10	25	0,3	4	105125	Δ	▲	Δ
L105.1819.2.H.4	0,2	1,9	3,7	2,9	7	15	30	0,3	4	105125	Δ	Δ	Δ
L105.1819.3.H.4	0,2	1,9	3,7	2,9	7	20	35	0,3	4	105125	Δ	▲	▲
L105.1823.1.H.5	0,2	2,3	4,7	4	7	10	25	0,5	5	105125	Δ	▲	▲
L105.1823.2.H.5	0,2	2,3	4,7	4	7	15	30	0,5	5	105125	Δ	Δ	Δ
L105.1823.3.H.5	0,2	2,3	4,7	4	7	20	35	0,5	5	105125	Δ	Δ	▲
L105.1823.4.H.5	0,2	2,3	4,7	4	7	25	40	0,5	5	105125	Δ	Δ	Δ
L105.1823.5.H.5	0,2	2,3	4,7	4	7	30	45	0,5	5	105125	Δ	Δ	Δ
P	●	●	●										
M	●	●	●										
K	○	●	●										
N	-	●	●										
S	-	●	●										
H	-	-	-										

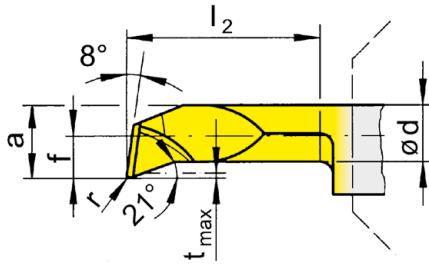
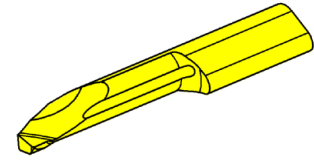
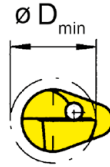
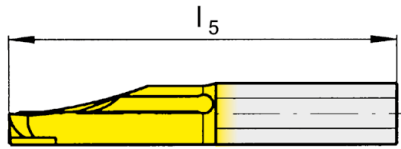
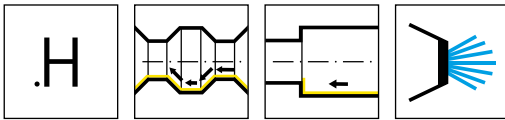

R = rechts wie gezeichnet
R = right hand version shown

L = links spiegelbildlich
L = left hand version

▲ ab Lager
on stock

HM-Sorten
Carbide grades
Δ 4 Wochen
4 weeks

Bestellnummer Part number	r	f	a	d	b	l_2	l_5	t_{max}	D_{min}	HIS	EG35	TF45	TH35
R105.1833.2.H.6	0,2	3,3	5,7	4,7	7	15	30	0,5	6	105125	Δ	▲	▲
R105.1833.3.H.6	0,2	3,3	5,7	4,7	7	20	35	0,5	6	105125	Δ	▲	▲
R105.1833.4.H.6	0,2	3,3	5,7	4,7	7	25	40	0,5	6	105125	Δ	▲	▲
R105.1833.5.H.6	0,2	3,3	5,7	4,7	7	30	45	0,5	6	105125	Δ	▲	▲
R105.1840.3.H.7	0,2	4	6,4	5,2	7	20	35	0,5	7	105125	▲	▲	▲
R105.1840.4.H.7	0,2	4	6,4	5,2	7	25	40	0,5	7	105125	Δ	▲	▲
R105.1840.5.H.7	0,2	4	6,4	5,2	7	30	45	0,5	7	105125	Δ	▲	▲
L105.1833.2.H.6	0,2	3,3	5,7	4,7	7	15	30	0,5	6	105125	Δ	Δ	Δ
L105.1833.3.H.6	0,2	3,3	5,7	4,7	7	20	35	0,5	6	105125	Δ	Δ	Δ
L105.1833.4.H.6	0,2	3,3	5,7	4,7	7	25	40	0,5	6	105125	Δ	Δ	Δ
L105.1833.5.H.6	0,2	3,3	5,7	4,7	7	30	45	0,5	6	105125	Δ	Δ	Δ
L105.1840.3.H.7	0,2	4	6,4	5,2	7	20	35	0,5	7	105125	Δ	▲	Δ
L105.1840.4.H.7	0,2	4	6,4	5,2	7	25	40	0,5	7	105125	Δ	Δ	Δ
L105.1840.5.H.7	0,2	4	6,4	5,2	7	30	45	0,5	7	105125	Δ	▲	Δ
P	●	●	●										
M	●	●	●										
K	○	●	●										
N	-	●	●										
S	-	●	●										
H	-	-	-										

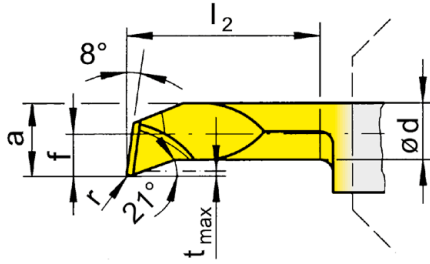
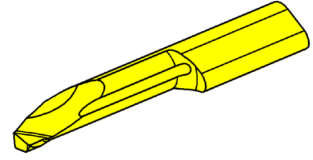
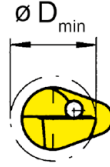
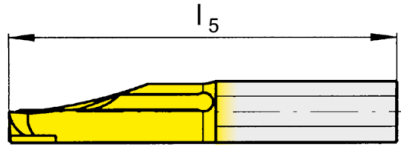
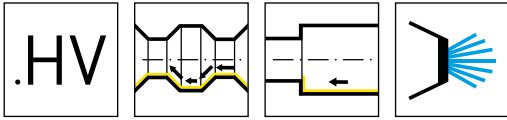

R = rechts wie gezeichnet
R = right hand version shown

L = links spiegelbildlich
L = left hand version

▲ ab Lager
on stock

HM-Sorten
Carbide grades
Δ 4 Wochen
4 weeks

Bestellnummer Part number	r	f	a	d	b	l ₂	l ₅	t _{max}	D _{min}	HIS	EG35	TH35
R105.1819.1.HV4	0,2	1,9	3,7	2,9	7	10	25	0,3	4	105125	Δ	▲
R105.1819.2.HV4	0,2	1,9	3,7	2,9	7	15	30	0,3	4	105125	Δ	▲
R105.1819.3.HV4	0,2	1,9	3,7	2,9	7	20	35	0,3	4	105125	Δ	▲
R105.1823.1.HV5	0,2	2,3	4,7	4	7	10	25	0,5	5	105125	Δ	▲
R105.1823.2.HV5	0,2	2,3	4,7	4	7	15	30	0,5	5	105125	▲	▲
R105.1823.3.HV5	0,2	2,3	4,7	4	7	20	35	0,5	5	105125	▲	▲
R105.1823.4.HV5	0,2	2,3	4,7	4	7	25	40	0,5	5	105125	Δ	▲
R105.1823.5.HV5	0,2	2,3	4,7	4	7	30	45	0,5	5	105125	▲	▲
L105.1819.1.HV4	0,2	1,9	3,7	2,9	7	10	25	0,3	4	105125	Δ	Δ
L105.1819.2.HV4	0,2	1,9	3,7	2,9	7	15	30	0,3	4	105125	Δ	▲
L105.1819.3.HV4	0,2	1,9	3,7	2,9	7	20	35	0,3	4	105125	Δ	▲
L105.1823.1.HV5	0,2	2,3	4,7	4	7	10	25	0,5	5	105125	Δ	▲
L105.1823.2.HV5	0,2	2,3	4,7	4	7	15	30	0,5	5	105125	Δ	▲
L105.1823.3.HV5	0,2	2,3	4,7	4	7	20	35	0,5	5	105125	Δ	▲
L105.1823.4.HV5	0,2	2,3	4,7	4	7	25	40	0,5	5	105125	Δ	Δ
L105.1823.5.HV5	0,2	2,3	4,7	4	7	30	45	0,5	5	105125	Δ	Δ
P	●	●										
M	●	●										
K	○	●										
N	-	●										
S	-	●										
H	-	-										

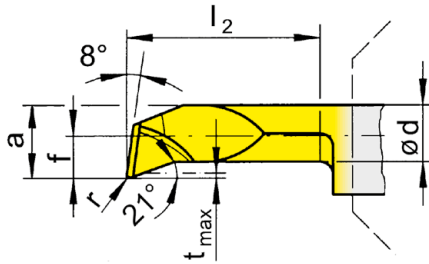
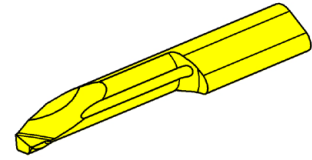
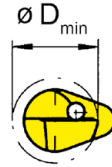
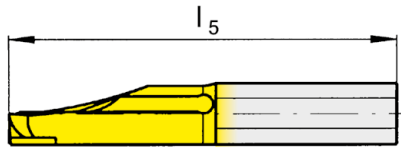
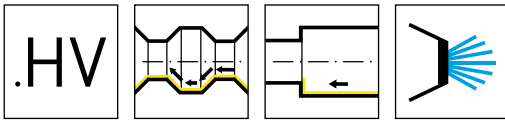

R = rechts wie gezeichnet
R = right hand version shown

L = links spiegelbildlich
L = left hand version

▲ ab Lager
on stock

HM-Sorten
Carbide grades
Δ 4 Wochen
4 weeks

Bestellnummer Part number	r	f	a	d	b	l ₂	l ₅	t _{max}	D _{min}	HIS	EG35	TH35
R105.1833.2.HV6	0,2	3,3	5,7	4,7	7	15	30	0,5	6	105125	Δ	▲
R105.1833.3.HV6	0,2	3,3	5,7	4,7	7	20	35	0,5	6	105125	▲	▲
R105.1833.4.HV6	0,2	3,3	5,7	4,7	7	25	40	0,5	6	105125	Δ	▲
R105.1833.5.HV6	0,2	3,3	5,7	4,7	7	30	45	0,5	6	105125	Δ	▲
R105.1840.2.HV7	0,2	4	6,4	5,2	7	15	30	0,5	7	105125	Δ	▲
R105.1840.3.HV7	0,2	4	6,4	5,2	7	20	35	0,5	7	105125	Δ	▲
R105.1840.4.HV7	0,2	4	6,4	5,2	7	25	40	0,5	7	105125	▲	▲
R105.1840.5.HV7	0,2	4	6,4	5,2	7	30	45	0,5	7	105125	Δ	▲
L105.1833.2.HV6	0,2	3,3	5,7	4,7	7	15	30	0,5	6	105125	Δ	▲
L105.1833.3.HV6	0,2	3,3	5,7	4,7	7	20	35	0,5	6	105125	Δ	Δ
L105.1833.4.HV6	0,2	3,3	5,7	4,7	7	25	40	0,5	6	105125	▲	▲
L105.1833.5.HV6	0,2	3,3	5,7	4,7	7	30	45	0,5	6	105125	Δ	Δ
L105.1840.2.HV7	0,2	4	6,4	5,2	7	15	30	0,5	7	105125	Δ	▲
L105.1840.3.HV7	0,2	4	6,4	5,2	7	20	35	0,5	7	105125		Δ
L105.1840.4.HV7	0,2	4	6,4	5,2	7	25	40	0,5	7	105125	Δ	Δ
L105.1840.5.HV7	0,2	4	6,4	5,2	7	30	45	0,5	7	105125	Δ	Δ
P	●	●										
M	●	●										
K	○	●										
N	-	●										
S	-	●										
H	-	-										

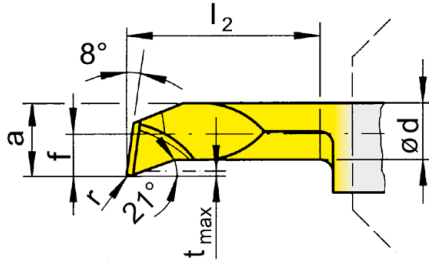
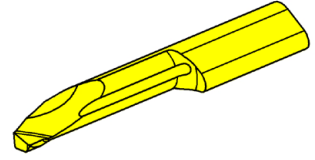
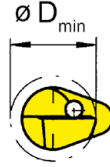
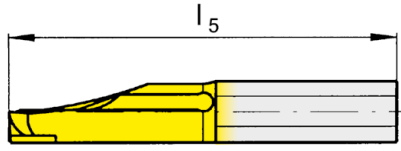
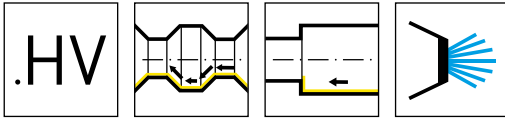

R = rechts wie gezeichnet
R = right hand version shown

L = links spiegelbildlich
L = left hand version

▲ ab Lager
on stock

HM-Sorten
Carbide grades
Δ 4 Wochen
4 weeks

Bestellnummer Part number	r	f	a	d	b	l ₂	l ₅	t _{max}	D _{min}	HIS	EG35	TH35
R105.1819.04.1.HV4	0,4	1,9	3,7	2,9	7	10	25	0,3	4	105125	▲	▲
R105.1819.04.2.HV4	0,4	1,9	3,7	2,9	7	15	30	0,3	4	105125	▲	▲
R105.1819.04.3.HV4	0,4	1,9	3,7	2,9	7	20	35	0,3	4	105125	Δ	▲
R105.1823.04.1.HV5	0,4	2,3	4,7	4	7	10	25	0,5	5	105125	Δ	▲
R105.1823.04.2.HV5	0,4	2,3	4,7	4	7	15	30	0,5	5	105125	▲	▲
R105.1823.04.3.HV5	0,4	2,3	4,7	4	7	20	35	0,5	5	105125	Δ	▲
R105.1823.04.4.HV5	0,4	2,3	4,7	4	7	25	40	0,5	5	105125	Δ	▲
R105.1823.04.5.HV5	0,4	2,3	4,7	4	7	30	45	0,5	5	105125	Δ	▲
L105.1819.04.1.HV4	0,4	1,9	3,7	2,9	7	10	25	0,3	4	105125	Δ	▲
L105.1819.04.2.HV4	0,4	1,9	3,7	2,9	7	15	30	0,3	4	105125	Δ	Δ
L105.1819.04.3.HV4	0,4	1,9	3,7	2,9	7	20	35	0,3	4	105125	Δ	Δ
L105.1823.04.1.HV5	0,4	2,3	4,7	4	7	10	25	0,5	5	105125	Δ	▲
L105.1823.04.2.HV5	0,4	2,3	4,7	4	7	15	30	0,5	5	105125	Δ	Δ
L105.1823.04.3.HV5	0,4	2,3	4,7	4	7	20	35	0,5	5	105125	Δ	Δ
L105.1823.04.4.HV5	0,4	2,3	4,7	4	7	25	40	0,5	5	105125	Δ	Δ
L105.1823.04.5.HV5	0,4	2,3	4,7	4	7	30	45	0,5	5	105125	Δ	▲
P	●	●										
M	●	●										
K	○	●										
N	-	●										
S	-	●										
H	-	-										

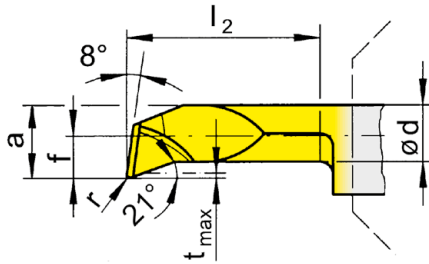
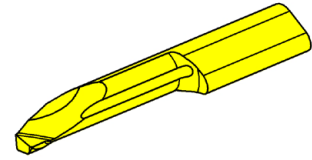
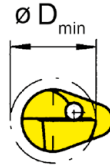
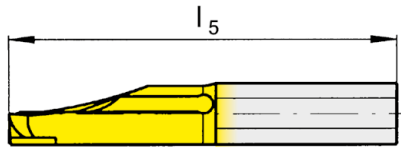
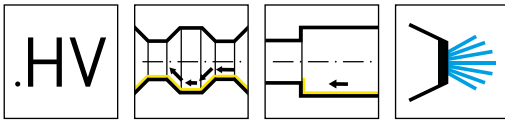

R = rechts wie gezeichnet
R = right hand version shown

L = links spiegelbildlich
L = left hand version

▲ ab Lager
on stock

HM-Sorten
Carbide grades
Δ 4 Wochen
4 weeks

Bestellnummer Part number	r	f	a	d	b	l ₂	l ₅	t _{max}	D _{min}	HIS	EG35	TH35
R105.1833.04.2.HV6	0,4	3,3	5,7	4,7	7	15	30	0,5	6	105125	Δ	▲
R105.1833.04.3.HV6	0,4	3,3	5,7	4,7	7	20	35	0,5	6	105125	▲	▲
R105.1833.04.4.HV6	0,4	3,3	5,7	4,7	7	25	40	0,5	6	105125	Δ	▲
R105.1833.04.5.HV6	0,4	3,3	5,7	4,7	7	30	45	0,5	6	105125	Δ	▲
R105.1840.04.2.HV7	0,4	4	6,4	5,2	7	15	30	0,5	7	105125	Δ	▲
R105.1840.04.3.HV7	0,4	4	6,4	5,2	7	20	35	0,5	7	105125	Δ	▲
R105.1840.04.4.HV7	0,4	4	6,4	5,2	7	25	40	0,5	7	105125	Δ	▲
R105.1840.04.5.HV7	0,4	4	6,4	5,2	7	30	45	0,5	7	105125	Δ	▲
L105.1833.04.2.HV6	0,4	3,3	5,7	4,7	7	15	30	0,5	6	105125		▲
L105.1833.04.3.HV6	0,4	3,3	5,7	4,7	7	20	35	0,5	6	105125	Δ	Δ
L105.1833.04.4.HV6	0,4	3,3	5,7	4,7	7	25	40	0,5	6	105125	Δ	Δ
L105.1833.04.5.HV6	0,4	3,3	5,7	4,7	7	30	45	0,5	6	105125	Δ	Δ
L105.1840.04.2.HV7	0,4	4	6,4	5,2	7	15	30	0,5	7	105125	Δ	▲
L105.1840.04.3.HV7	0,4	4	6,4	5,2	7	20	35	0,5	7	105125	Δ	▲
L105.1840.04.4.HV7	0,4	4	6,4	5,2	7	25	40	0,5	7	105125	Δ	Δ
L105.1840.04.5.HV7	0,4	4	6,4	5,2	7	30	45	0,5	7	105125		Δ
P	●	●										
M	●	●										
K	○	●										
N	-	●										
S	-	●										
H	-	-										

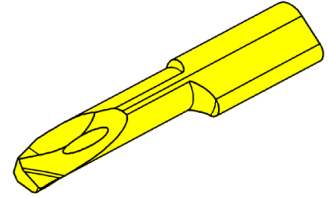
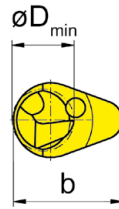
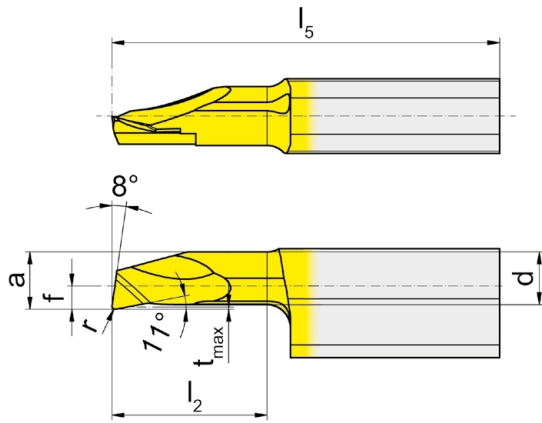
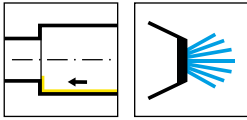

R = rechts wie gezeichnet
R = right hand version shown

L = links spiegelbildlich
L = left hand version

▲ ab Lager
on stock

HM-Sorten
Carbide grades
Δ 4 Wochen
4 weeks

Bestellnummer Part number	r	f	a	d	b	l ₂	l ₅	t _{max}	D _{min}	HIS	EG35	TH35
R105.1019.005.1.4	0,05	1,5	3,7	3,4	7	10	25	0,15	4	105125	▲	▲
R105.1019.005.2.4	0,05	1,5	3,7	3,4	7	15	30	0,15	4	105125	Δ	▲
R105.1019.005.3.4	0,05	1,5	3,7	3,4	7	20	35	0,15	4	105125	Δ	▲
R105.1019.005.4.4	0,05	1,5	3,7	3,4	7	25	40	0,15	4	105125	Δ	▲
R105.1019.1.4	0,2	1,5	3,7	3,4	7	10	25	0,15	4	105125	▲	▲
R105.1019.2.4	0,2	1,5	3,7	3,4	7	15	30	0,15	4	105125	▲	▲
R105.1019.3.4	0,2	1,5	3,7	3,4	7	20	35	0,15	4	105125	▲	▲
R105.1019.4.4	0,2	1,5	3,7	3,4	7	25	40	0,15	4	105125	▲	▲
L105.1019.005.1.4	0,05	1,5	3,7	3,4	7	10	25	0,15	4	105125	▲	▲
L105.1019.005.2.4	0,05	1,5	3,7	3,4	7	15	30	0,15	4	105125	Δ	▲
L105.1019.005.3.4	0,05	1,5	3,7	3,4	7	20	35	0,15	4	105125	Δ	▲
L105.1019.005.4.4	0,05	1,5	3,7	3,4	7	25	40	0,15	4	105125	Δ	▲
L105.1019.1.4	0,2	1,5	3,7	3,4	7	10	25	0,15	4	105125	Δ	▲
L105.1019.2.4	0,2	1,5	3,7	3,4	7	15	30	0,15	4	105125	Δ	▲
L105.1019.3.4	0,2	1,5	3,7	3,4	7	20	35	0,15	4	105125	Δ	▲
L105.1019.4.4	0,2	1,5	3,7	3,4	7	25	40	0,15	4	105125	Δ	▲

verstärkte Ausführung
reinforced version

P	●	●
M	●	●
K	○	●
N	-	●
S	-	●
H	-	-

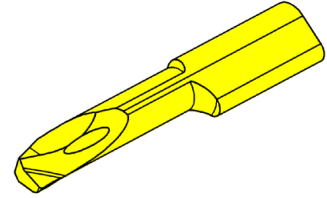
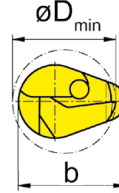
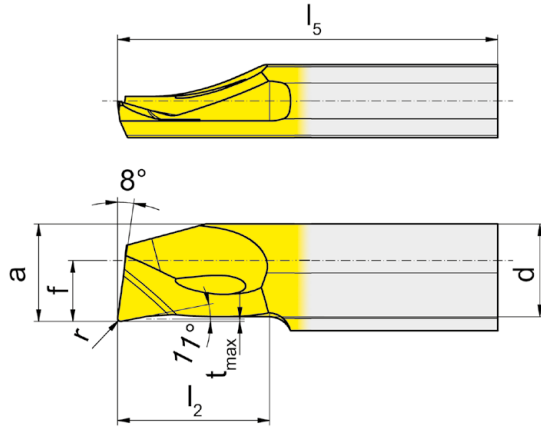
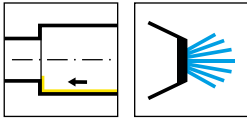

R = rechts wie gezeichnet
R = right hand version shown

L = links spiegelbildlich
L = left hand version

▲ ab Lager
on stock

HM-Sorten
Carbide grades
Δ 4 Wochen
4 weeks

Bestellnummer Part number	r	f	a	d	b	l ₂	l ₅	t _{max}	D _{min}	HIS	EG35	TH35
R105.1023.005.1.5	0,05	2,8	4,7	4,4	7	10	25	0,15	5	105125	▲	▲
R105.1023.005.2.5	0,05	2,8	4,7	4,4	7	15	30	0,15	5	105125	▲	▲
R105.1023.005.3.5	0,05	2,8	4,7	4,4	7	20	35	0,15	5	105125	Δ	▲
R105.1023.005.4.5	0,05	2,8	4,7	4,4	7	25	40	0,15	5	105125	Δ	▲
R105.1023.005.5.5	0,05	2,8	4,7	4,4	7	30	45	0,15	5	105125	Δ	▲
R105.1023.005.6.5	0,05	2,8	4,7	4,4	7	35	50	0,15	5	105125	Δ	▲
R105.1023.1.5	0,2	2,8	4,7	4,4	7	10	25	0,15	5	105125	▲	▲
R105.1023.2.5	0,2	2,8	4,7	4,4	7	15	30	0,15	5	105125	▲	▲
R105.1023.3.5	0,2	2,8	4,7	4,4	7	20	35	0,15	5	105125	▲	▲
R105.1023.4.5	0,2	2,8	4,7	4,4	7	25	40	0,15	5	105125	▲	▲
R105.1023.5.5	0,2	2,8	4,7	4,4	7	30	45	0,15	5	105125	▲	▲
R105.1023.6.5	0,2	2,8	4,7	4,4	7	35	50	0,15	5	105125	▲	▲
L105.1023.005.1.5	0,05	2,8	4,7	4,4	7	10	25	0,15	5	105125	Δ	▲
L105.1023.005.2.5	0,05	2,8	4,7	4,4	7	15	30	0,15	5	105125	Δ	Δ
L105.1023.005.3.5	0,05	2,8	4,7	4,4	7	20	35	0,15	5	105125	Δ	▲
L105.1023.005.4.5	0,05	2,8	4,7	4,4	7	25	40	0,15	5	105125	Δ	▲
L105.1023.005.5.5	0,05	2,8	4,7	4,4	7	30	45	0,15	5	105125	Δ	▲
L105.1023.005.6.5	0,05	2,8	4,7	4,4	7	35	50	0,15	5	105125	Δ	▲
L105.1023.1.5	0,2	2,8	4,7	4,4	7	10	25	0,15	5	105125	Δ	▲
L105.1023.2.5	0,2	2,8	4,7	4,4	7	15	30	0,15	5	105125		▲
L105.1023.3.5	0,2	2,8	4,7	4,4	7	20	35	0,15	5	105125	Δ	▲
L105.1023.4.5	0,2	2,8	4,7	4,4	7	25	40	0,15	5	105125	Δ	▲
L105.1023.5.5	0,2	2,8	4,7	4,4	7	30	45	0,15	5	105125	Δ	▲
L105.1023.6.5	0,2	2,8	4,7	4,4	7	35	50	0,15	5	105125	Δ	▲

verstärkte Ausführung
reinforced version

P	●	●
M	●	●
K	○	●
N	-	●
S	-	●
H	-	-

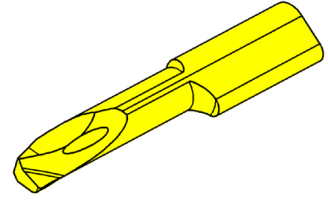
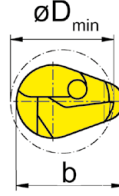
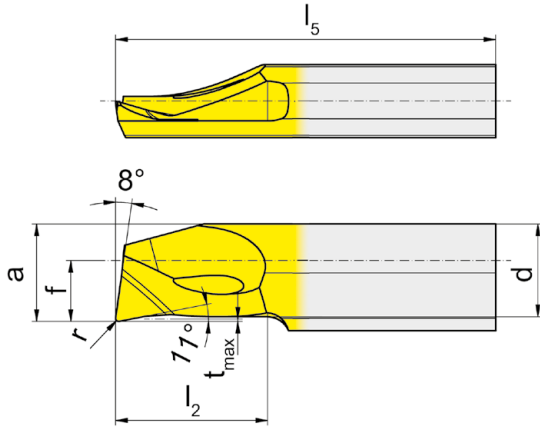
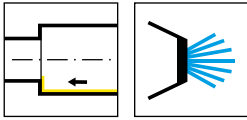

R = rechts wie gezeichnet
R = right hand version shown

L = links spiegelbildlich
L = left hand version

▲ ab Lager
on stock

HM-Sorten
Carbide grades
Δ 4 Wochen
4 weeks

Bestellnummer Part number	r	f	a	d	b	l_2	l_5	t_{max}	D_{min}	HIS	EG35	TH35
R105.1033.005.1.6	0,05	3,3	5,7	5,4	7	10	25	0,15	6	105125	▲	▲
R105.1033.005.2.6	0,05	3,3	5,7	5,4	7	15	30	0,15	6	105125	Δ	▲
R105.1033.005.3.6	0,05	3,3	5,7	5,4	7	20	35	0,15	6	105125	▲	▲
R105.1033.005.4.6	0,05	3,3	5,7	5,4	7	25	40	0,15	6	105125	Δ	▲
R105.1033.005.5.6	0,05	3,3	5,7	5,4	7	30	45	0,15	6	105125	Δ	▲
R105.1033.005.6.6	0,05	3,3	5,7	5,4	7	35	50	0,15	6	105125	Δ	▲
R105.1033.1.6	0,2	3,3	5,7	5,4	7	10	25	0,15	6	105125	▲	▲
R105.1033.2.6	0,2	3,3	5,7	5,4	7	15	30	0,15	6	105125	▲	▲
R105.1033.3.6	0,2	3,3	5,7	5,4	7	20	35	0,15	6	105125	▲	▲
R105.1033.4.6	0,2	3,3	5,7	5,4	7	25	40	0,15	6	105125	▲	▲
R105.1033.5.6	0,2	3,3	5,7	5,4	7	30	45	0,15	6	105125	▲	▲
R105.1033.6.6	0,2	3,3	5,7	5,4	7	35	50	0,15	6	105125	▲	▲
L105.1033.005.1.6	0,05	3,3	5,7	5,4	7	10	25	0,15	6	105125	Δ	▲
L105.1033.005.2.6	0,05	3,3	5,7	5,4	7	15	30	0,15	6	105125	Δ	▲
L105.1033.005.3.6	0,05	3,3	5,7	5,4	7	20	35	0,15	6	105125	Δ	▲
L105.1033.005.4.6	0,05	3,3	5,7	5,4	7	25	40	0,15	6	105125	Δ	Δ
L105.1033.005.5.6	0,05	3,3	5,7	5,4	7	30	45	0,15	6	105125	Δ	▲
L105.1033.005.6.6	0,05	3,3	5,7	5,4	7	35	50	0,15	6	105125	Δ	▲
L105.1033.1.6	0,2	3,3	5,7	5,4	7	10	25	0,15	6	105125		▲
L105.1033.2.6	0,2	3,3	5,7	5,4	7	15	30	0,15	6	105125	Δ	▲
L105.1033.3.6	0,2	3,3	5,7	5,4	7	20	35	0,15	6	105125	Δ	▲
L105.1033.4.6	0,2	3,3	5,7	5,4	7	25	40	0,15	6	105125	Δ	▲
L105.1033.5.6	0,2	3,3	5,7	5,4	7	30	45	0,15	6	105125	Δ	▲
L105.1033.6.6	0,2	3,3	5,7	5,4	7	35	50	0,15	6	105125	Δ	▲

verstärkte Ausführung
reinforced version

P	●	●
M	●	●
K	○	●
N	-	●
S	-	●
H	-	-

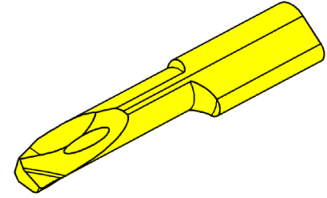
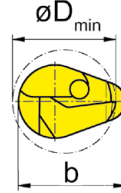
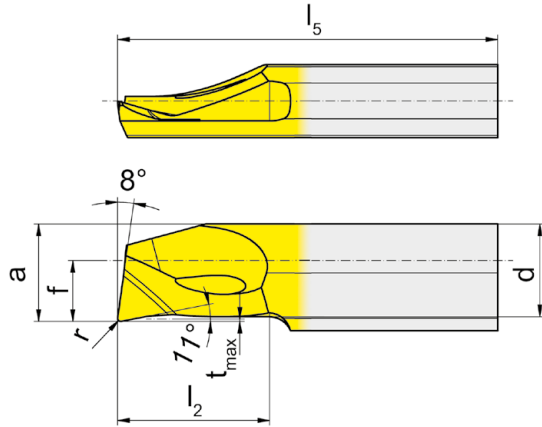
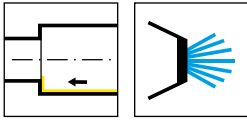

R = rechts wie gezeichnet
R = right hand version shown

L = links spiegelbildlich
L = left hand version

▲ ab Lager
on stock

HM-Sorten
Carbide grades
Δ 4 Wochen
4 weeks

Bestellnummer Part number	r	f	a	d	b	l_2	l_5	t_{max}	D_{min}	HIS	EG35	TH35
R105.1040.1.7	0,2	4	6,4	6,1	7	10	25	0,15	6,8	105125	▲	▲
R105.1040.2.7	0,2	4	6,4	6,1	7	15	30	0,15	6,8	105125	▲	▲
R105.1040.3.7	0,2	4	6,4	6,1	7	20	35	0,15	6,8	105125	▲	▲
R105.1040.4.7	0,2	4	6,4	6,1	7	25	40	0,15	6,8	105125	▲	▲
R105.1040.5.7	0,2	4	6,4	6,1	7	30	45	0,15	6,8	105125	▲	▲
R105.1040.6.7	0,2	4	6,4	6,1	7	35	50	0,15	6,8	105125	▲	▲
L105.1040.1.7	0,2	4	6,4	6,1	7	10	25	0,15	6,8	105125	Δ	▲
L105.1040.2.7	0,2	4	6,4	6,1	7	15	30	0,15	6,8	105125	Δ	▲
L105.1040.3.7	0,2	4	6,4	6,1	7	20	35	0,15	6,8	105125	Δ	▲
L105.1040.4.7	0,2	4	6,4	6,1	7	25	40	0,15	6,8	105125	Δ	▲
L105.1040.5.7	0,2	4	6,4	6,1	7	30	45	0,15	6,8	105125	Δ	▲
L105.1040.6.7	0,2	4	6,4	6,1	7	35	50	0,15	6,8	105125	Δ	▲

verstärkte Ausführung
reinforced version

P	●	●
M	●	●
K	○	●
N	-	●
S	-	●
H	-	-

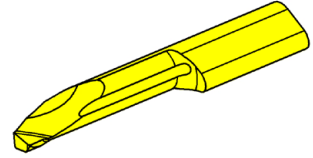
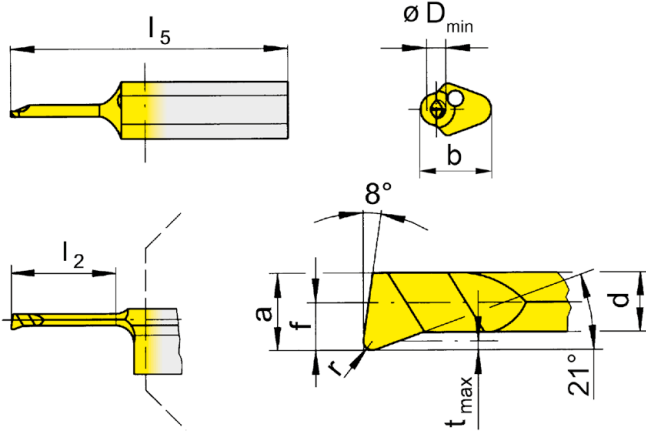
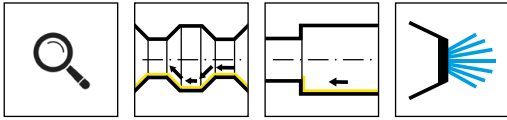

R = rechts wie gezeichnet
R = right hand version shown

L = links spiegelbildlich
L = left hand version

▲ ab Lager
on stock

HM-Sorten
Carbide grades
Δ 4 Wochen
4 weeks

Bestellnummer Part number	r	f	a	d	b	l_2	l_5	t_{max}	D_{min}	HIS	ES15
R105.2108.003.0.1	0,03	0,5	0,9	0,65	5,9	4	25	0,1	1	105123	▲
R105.2108.003.0.15	0,03	1,3	1,4	1,1	5,9	6	25	0,15	1,5	105123	▲
R105.2108.003.1.1	0,03	0,5	0,9	0,65	5,9	6	25	0,1	1	105123	▲
R105.2108.003.1.15	0,03	1,3	1,4	1,1	5,9	9	25	0,15	1,5	105123	▲
R105.2108.003.2.1	0,03	0,5	0,9	0,65	5,9	8	25	0,1	1	105123	▲
R105.2108.003.2.15	0,03	1,3	1,4	1,1	5,9	12	25	0,15	1,5	105123	▲
R105.2108.008.0.1	0,08	0,5	0,9	0,65	5,9	4	25	0,1	1	105123	▲
R105.2108.008.0.15	0,08	1,3	1,4	1,1	5,9	6	25	0,15	1,5	105123	▲
R105.2108.008.1.1	0,08	0,5	0,9	0,65	5,9	6	25	0,1	1	105123	▲
R105.2108.008.1.15	0,08	1,3	1,4	1,1	5,9	9	25	0,15	1,5	105123	▲
R105.2108.008.2.1	0,08	0,5	0,9	0,65	5,9	8	25	0,1	1	105123	▲
R105.2108.008.2.15	0,08	1,3	1,4	1,1	5,9	12	30	0,15	1,5	105123	▲
											P ●
											M ●
											K ○
											N -
											S -
											H -

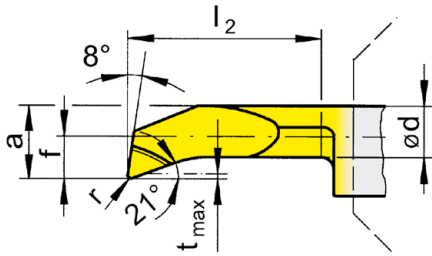
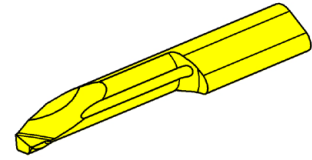
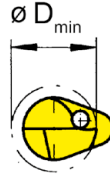
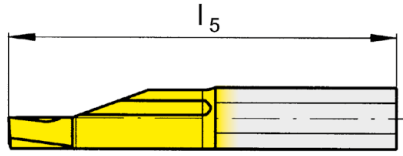
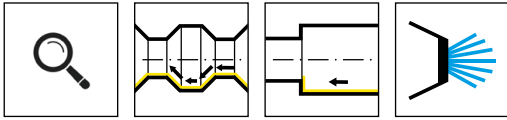

R = rechts wie gezeichnet
R = right hand version shown

L = links spiegelbildlich
L = left hand version

▲ ab Lager
on stock

HM-Sorten
Carbide grades
Δ 4 Wochen
4 weeks

Bestellnummer Part number	r	f	a	d	b	l ₂	l ₅	t _{max}	D _{min}	HIS	ES15
R105.2108.003.0.2	0,03	1	1,9	1,6	5,9	6	25	0,15	2	105123	▲
R105.2108.003.1.2	0,03	1	1,9	1,6	5,9	9	25	0,15	2	105123	▲
R105.2108.003.2.2	0,03	1	1,9	1,6	5,9	12	30	0,15	2	105123	▲
R105.2108.008.0.2	0,08	1	1,9	1,6	5,9	6	25	0,15	2	105123	▲
R105.2108.008.1.2	0,08	1	1,9	1,6	5,9	9	25	0,15	2	105123	▲
R105.2108.008.2.2	0,08	1	1,9	1,6	5,9	12	30	0,15	2	105123	▲
R105.2108.003.1.3	0,03	1,3	2,6	2,3	5,9	10	25	0,15	3	105123	▲
R105.2108.003.2.3	0,03	1,3	2,6	2,3	5,9	15	30	0,15	3	105123	▲
R105.2108.003.3.3	0,03	1,3	2,6	2,3	5,9	20	35	0,15	3	105123	▲
R105.2108.008.1.3	0,08	1,3	2,6	2,3	5,9	10	25	0,15	3	105123	▲
R105.2108.008.2.3	0,08	1,3	2,6	2,3	5,9	15	30	0,15	3	105123	▲
R105.2108.008.3.3	0,08	1,3	2,6	2,3	5,9	20	35	0,15	3	105123	▲
P	●										
M	●										
K	o										
N	-										
S	-										
H	-										

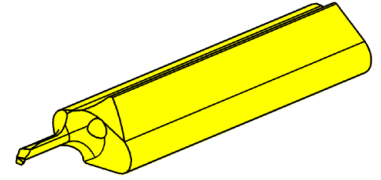
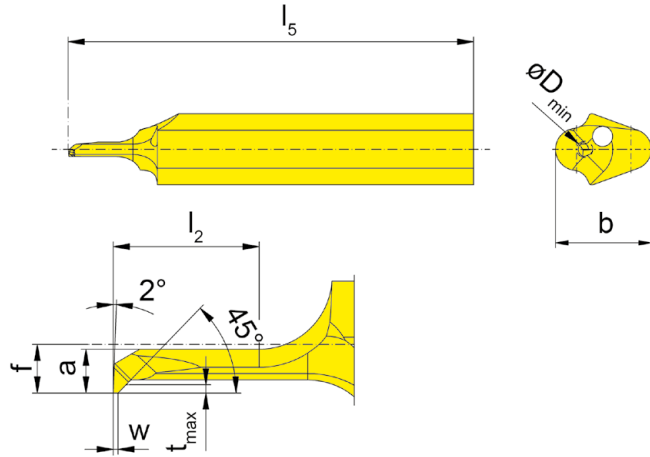
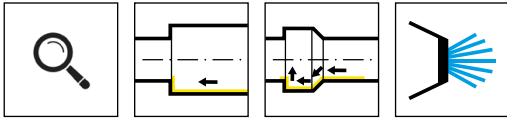

R = rechts wie gezeichnet
R = right hand version shown

L = links spiegelbildlich
L = left hand version

▲ ab Lager
on stock

HM-Sorten
Carbide grades
Δ 4 Wochen
4 weeks

Bestellnummer Part number	w	f	a	b	l ₂	l ₅	t _{max}	D _{min}	HIS	ES15
R105.4502.003.0.03	0,03	1	0,25	5,9	0,6	25	0,05	0,3	105123	▲
R105.4502.003.0.04	0,03	1	0,33	5,9	0,8	25	0,07	0,4	105123	▲
R105.4502.003.0.05	0,03	1	0,45	5,9	1,2	25	0,08	0,5	105123	▲
R105.4502.003.0.06	0,03	1	0,52	5,9	1,2	25	0,1	0,6	105123	▲
R105.4502.003.0.07	0,03	1	0,6	5,9	1,2	25	0,12	0,7	105123	▲
R105.4502.005.0.08	0,05	1	0,7	5,9	1,8	25	0,15	0,8	105123	▲
R105.4502.005.0.09	0,05	1	0,8	5,9	1,8	25	0,15	0,9	105123	▲
R105.4502.010.0.10	0,1	1	0,9	5,9	3	25	0,17	1	105123	▲
R105.4502.010.0.12	0,1	1	1	5,9	3,6	25	0,2	1,2	105123	▲
R105.4502.010.0.15	0,1	1,3	1,4	5,9	4,5	25	0,25	1,5	105123	▲
R105.4502.020.0.20	0,2	1,3	1,8	5,9	6	25	0,35	2	105123	▲
R105.4502.020.0.25	0,2	1,3	2,3	5,9	7,5	25	0,45	2,5	105123	▲
R105.4502.030.0.30	0,3	1,3	2,6	5,9	9	25	0,5	3	105123	▲
R105.4502.030.0.35	0,3	1,9	3,2	6,4	10	25	0,6	3,5	105124	▲
										P ●
										M ●
										K ○
										N -
										S -
										H -

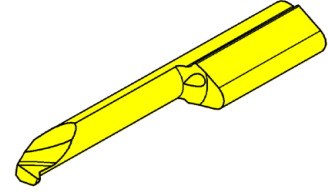
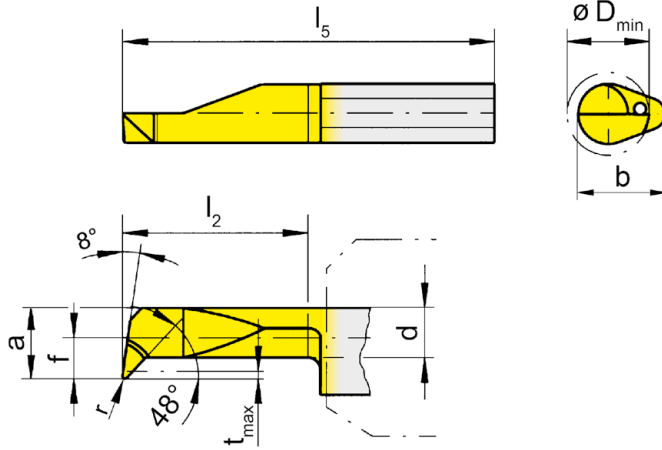
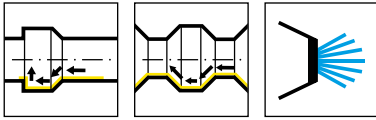

R = rechts wie gezeichnet
R = right hand version shown

L = links spiegelbildlich
L = left hand version

▲ ab Lager
on stock

HM-Sorten
Carbide grades
Δ 4 Wochen
4 weeks

Bestellnummer Part number	r	f	a	d	b	l ₂	l ₅	t _{max}	D _{min}	HIS	MG12	EG35	ES15	TH35	TI25	TN35
R105.4715.005.1.2	0,05	1,5	1,9	1,45	5,9	9	25	0,3	2	105123		▲	▲			
R105.4715.005.2.2	0,05	1,5	1,9	1,45	5,9	12	30	0,3	2	105123		▲	Δ			
R105.4713.005.1.3	0,05	1,3	2,6	2	5,9	10	25	0,4	3	105123	▲	▲	▲			
R105.4713.005.2.3	0,05	1,3	2,6	2	5,9	15	30	0,4	3	105123		▲	▲			
R105.4719.1.4	0,15	1,9	3,7	2,9	6,4	10	25	0,6	4	105124		▲		▲		
R105.4719.3.4	0,15	1,9	3,7	2,9	6,4	20	35	0,6	4	105124	Δ	▲		▲	▲	▲
R105.4723.2.5	0,15	2,3	4,7	3,7	7	15	30	0,8	5	105125		▲		▲		Δ
R105.4723.4.5	0,15	2,3	4,7	3,7	7	25	40	0,8	5	105125		▲		▲	▲	▲
R105.4733.3.6	0,15	3,3	5,7	3,7	7	20	35	1,8	6	105125		▲		▲		
R105.4733.5.6	0,15	3,3	5,7	3,7	7	30	45	1,8	6	105125	Δ	▲		▲	Δ	▲
L105.4719.1.4	0,15	1,9	3,7	2,9	6,4	10	25	0,6	4	105124		▲		▲		
L105.4719.3.4	0,15	1,9	3,7	2,9	6,4	20	35	0,6	4	105124		▲		▲	▲	▲
L105.4723.2.5	0,15	2,3	4,7	3,7	7	15	30	0,8	5	105125		Δ		▲		
L105.4723.4.5	0,15	2,3	4,7	3,7	7	25	40	0,8	5	105125		▲		▲	▲	▲
L105.4733.3.6	0,15	3,3	5,7	3,7	7	20	35	1,8	6	105125		Δ		▲		
L105.4733.5.6	0,15	3,3	5,7	3,7	7	30	45	1,8	6	105125		▲		▲	Δ	▲
P	o	•	•	•	•	•	•	•	•							
M	-	•	•	•	•	•	•	•	•							
K	-	o	o	•	•	•	•	•	•							
N	-	-	-	•	•	•	•	•	•							
S	-	-	-	•	•	•	•	•	•							
H	-	-	-	-	-	-	-	-	-							

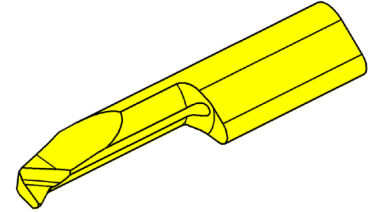
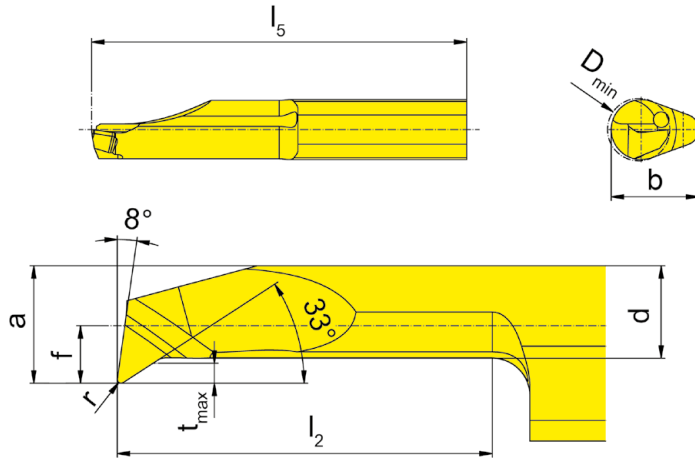
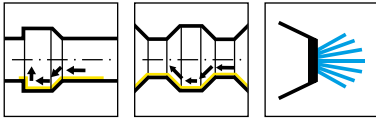

R = rechts wie gezeichnet
R = right hand version shown

L = links spiegelbildlich
L = left hand version

▲ ab Lager
on stock

HM-Sorten
Carbide grades
Δ 4 Wochen
4 weeks

Bestellnummer Part number	r	f	a	d	b	l ₂	l ₅	t _{max}	D _{min}	HIS	EG35
R105.3313.005.1.3	0,05	1,3	2,6	2	5,9	10	25	0,4	3	105123	▲
R105.3313.005.2.3	0,05	1,3	2,6	2	5,9	15	30	0,4	3	105123	▲
R105.3315.005.1.2	0,05	1,5	1,9	1,45	5,9	9	25	0,3	2	105123	▲
R105.3315.005.2.2	0,05	1,5	1,9	1,45	5,9	12	30	0,3	2	105123	▲
R105.3319.1.4	0,15	1,9	3,7	2,9	6,4	10	25	0,6	4	105124	▲
R105.3319.3.4	0,15	1,9	3,7	2,9	6,4	20	35	0,6	4	105124	▲
R105.3323.2.5	0,15	2,3	4,7	3,7	7	15	30	0,8	5	105125	▲
R105.3323.4.5	0,15	2,3	4,7	3,7	7	25	40	0,8	5	105125	▲
R105.3333.3.6	0,15	3,3	5,7	3,7	7	20	35	1,8	6	105125	▲
R105.3333.5.6	0,15	3,3	5,7	3,7	7	30	45	1,8	6	105125	▲
L105.3319.1.4	0,15	1,9	3,7	2,9	6,4	10	25	0,6	4	105124	Δ
L105.3319.3.4	0,15	1,9	3,7	2,9	6,4	20	35	0,6	4	105124	Δ
L105.3323.2.5	0,15	2,3	4,7	3,7	7	15	30	0,8	5	105125	Δ
L105.3323.4.5	0,15	2,3	4,7	3,7	7	25	40	0,8	5	105125	Δ
L105.3333.3.6	0,15	3,3	5,7	3,7	7	20	35	1,8	6	105125	Δ
L105.3333.5.6	0,15	3,3	5,7	3,7	7	30	45	1,8	6	105125	Δ

P	●
M	●
K	o
N	-
S	-
H	-

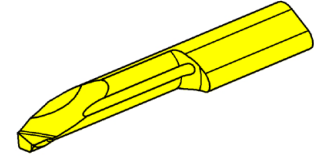
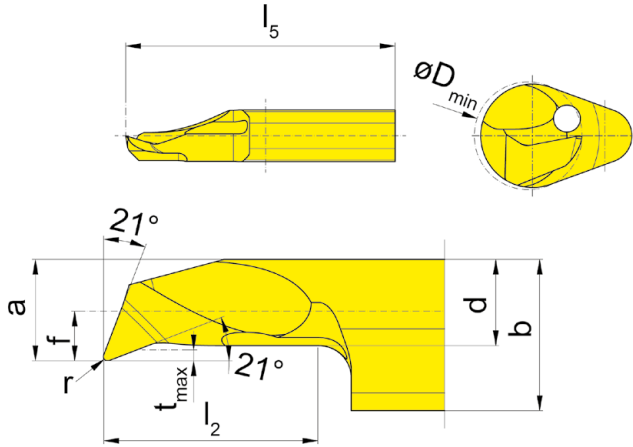
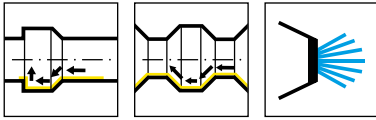

R = rechts wie gezeichnet
R = right hand version shown

L = links spiegelbildlich
L = left hand version

▲ ab Lager
on stock

HM-Sorten
Carbide grades
Δ 4 Wochen
4 weeks

Bestellnummer Part number	r	f	a	d	b	l ₂	l ₅	t _{max}	D _{min}	HIS	EG35
R105.2113.1.3	0,1	1,3	2,6	2,3	5,9	10	25	0,15	3	105123	▲
R105.2113.2.3	0,1	1,3	2,6	2,3	5,9	15	30	0,15	3	105123	▲
R105.2113.3.3	0,1	1,3	2,6	2,3	5,9	20	35	0,15	3	105123	▲
R105.2119.1.4	0,15	1,9	3,7	3	6,4	10	25	0,3	4	105124	▲
R105.2119.2.4	0,15	1,9	3,7	3	6,4	15	30	0,3	4	105124	▲
R105.2119.3.4	0,15	1,9	3,7	3	6,4	20	35	0,3	4	105124	▲
R105.2119.4.4	0,15	1,9	3,7	3	6,4	25	40	0,3	4	105124	Δ
R105.2123.1.5	0,2	2,3	4,7	4	7	10	25	0,5	5	105125	Δ
R105.2123.2.5	0,2	2,3	4,7	4	7	15	30	0,5	5	105125	▲
R105.2123.3.5	0,2	2,3	4,7	4	7	20	35	0,5	5	105125	▲
R105.2123.4.5	0,2	2,3	4,7	4	7	25	40	0,5	5	105125	Δ
R105.2123.5.5	0,2	2,3	4,7	4	7	30	45	0,5	5	105125	Δ
R105.2123.6.5	0,2	2,3	4,7	4	7	35	50	0,5	5	105125	▲
L105.2113.1.3	0,1	1,3	2,6	2,3	5,9	10	25	0,15	3	105123	▲
L105.2113.2.3	0,1	1,3	2,6	2,3	5,9	15	30	0,15	3	105123	▲
L105.2113.3.3	0,1	1,3	2,6	2,3	5,9	20	35	0,15	3	105123	▲
L105.2119.1.4	0,15	1,9	3,7	3	6,4	10	25	0,3	4	105124	▲
L105.2119.2.4	0,15	1,9	3,7	3	6,4	15	30	0,3	4	105124	Δ
L105.2119.3.4	0,15	1,9	3,7	3	6,4	20	35	0,3	4	105124	▲
L105.2119.4.4	0,15	1,9	3,7	3	6,4	25	40	0,3	4	105124	Δ
L105.2123.1.5	0,2	2,3	4,7	4	7	10	25	0,5	5	105125	Δ
L105.2123.2.5	0,2	2,3	4,7	4	7	15	30	0,5	5	105125	▲
L105.2123.3.5	0,2	2,3	4,7	4	7	20	35	0,5	5	105125	Δ
L105.2123.4.5	0,2	2,3	4,7	4	7	25	40	0,5	5	105125	Δ
L105.2123.5.5	0,2	2,3	4,7	4	7	30	45	0,5	5	105125	Δ
L105.2123.6.5	0,2	2,3	4,7	4	7	35	50	0,5	5	105125	Δ

P	●
M	●
K	○
N	-
S	-
H	-

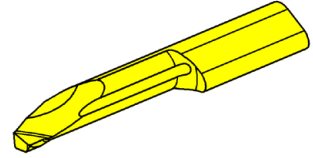
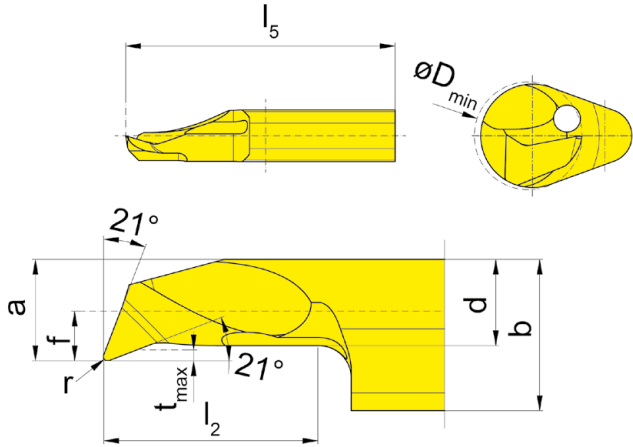
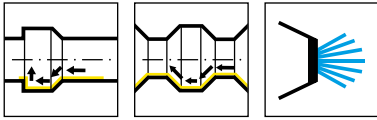

R = rechts wie gezeichnet
R = right hand version shown

L = links spiegelbildlich
L = left hand version

HM-Sorten
Carbide grades
▲ ab Lager
on stock
Δ 4 Wochen
4 weeks

Bestellnummer Part number	r	f	a	d	b	l ₂	l ₅	t _{max}	D _{min}	HIS	EG35
R105.2133.1.6	0,2	3,3	5,7	4,7	7	10	25	0,5	6	105125	▲
R105.2133.2.6	0,2	3,3	5,7	4,7	7	15	30	0,5	6	105125	▲
R105.2133.3.6	0,2	3,3	5,7	4,7	7	20	35	0,5	6	105125	▲
R105.2133.4.6	0,2	3,3	5,7	4,7	7	25	40	0,5	6	105125	Δ
R105.2133.5.6	0,2	3,3	5,7	4,7	7	30	45	0,5	6	105125	Δ
R105.2133.6.6	0,2	3,3	5,7	4,7	7	35	50	0,5	6	105125	Δ
R105.2140.1.7	0,2	4	6,4	5,2	7	10	25	0,5	7	105125	▲
R105.2140.2.7	0,2	4	6,4	5,2	7	15	30	0,5	7	105125	▲
R105.2140.3.7	0,2	4	6,4	5,2	7	20	35	0,5	7	105125	▲
R105.2140.4.7	0,2	4	6,4	5,2	7	25	40	0,5	7	105125	Δ
R105.2140.5.7	0,2	4	6,4	5,2	7	30	45	0,5	7	105125	Δ
R105.2140.6.7	0,2	4	6,4	5,2	7	35	50	0,5	7	105125	Δ
L105.2133.1.6	0,2	3,3	5,7	4,7	7	10	25	0,5	6	105125	▲
L105.2133.2.6	0,2	3,3	5,7	4,7	7	15	30	0,5	6	105125	▲
L105.2133.3.6	0,2	3,3	5,7	4,7	7	20	35	0,5	6	105125	▲
L105.2133.4.6	0,2	3,3	5,7	4,7	7	25	40	0,5	6	105125	Δ
L105.2133.5.6	0,2	3,3	5,7	4,7	7	30	45	0,5	6	105125	Δ
L105.2133.6.6	0,2	3,3	5,7	4,7	7	35	50	0,5	6	105125	Δ
L105.2140.1.7	0,2	4	6,4	5,2	7	10	25	0,5	7	105125	▲
L105.2140.2.7	0,2	4	6,4	5,2	7	15	30	0,5	7	105125	▲
L105.2140.3.7	0,2	4	6,4	5,2	7	20	35	0,5	7	105125	Δ
L105.2140.4.7	0,2	4	6,4	5,2	7	25	40	0,5	7	105125	Δ
L105.2140.5.7	0,2	4	6,4	5,2	7	30	45	0,5	7	105125	Δ
L105.2140.6.7	0,2	4	6,4	5,2	7	35	50	0,5	7	105125	Δ

P	●
M	●
K	○
N	-
S	-
H	-

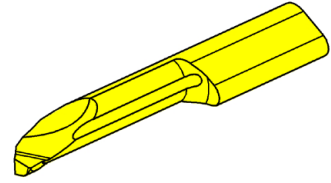
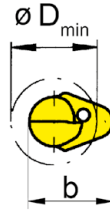
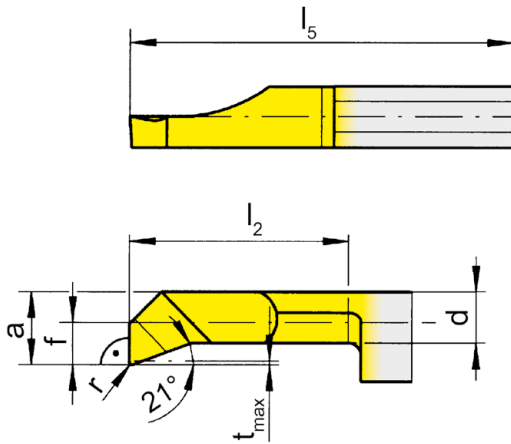
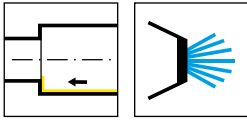

R = rechts wie gezeichnet
R = right hand version shown

L = links spiegelbildlich
L = left hand version

▲ ab Lager
on stock

HM-Sorten
Carbide grades
Δ 4 Wochen
4 weeks

Bestellnummer Part number	r	f	a	d	b	l ₂	l ₅	t _{max}	D _{min}	HIS	EG35	TH35	TI25	TN35
R105.9013.01.1.3	0,1	1,3	2,6	2,3	5,9	10	25	0,15	3	105123	Δ	▲		
R105.9013.01.2.3	0,1	1,3	2,6	2,3	5,9	15	30	0,15	3	105123	Δ	▲		
R105.9013.01.3.3	0,1	1,3	2,6	2,3	5,9	20	35	0,15	3	105123	▲	Δ		
R105.9013.1.3	0,2	1,3	2,6	2,3	5,9	10	25	0,15	3	105123	▲			▲
R105.9013.2.3	0,2	1,3	2,6	2,3	5,9	15	30	0,15	3	105123	▲			▲
R105.9019.01.1.4	0,1	1,9	3,7	2,9	6,4	10	25	0,3	4	105124	Δ	▲		
R105.9019.01.2.4	0,1	1,9	3,7	2,9	6,4	15	30	0,3	4	105124	Δ	▲		
R105.9019.01.3.4	0,1	1,9	3,7	2,9	6,4	20	35	0,3	4	105124	▲	▲		
R105.9019.1.4	0,2	1,9	3,7	2,9	6,4	10	25	0,3	4	105124	▲			▲
R105.9019.2.4	0,2	1,9	3,7	2,9	6,4	15	30	0,3	4	105124	▲		Δ	▲
L105.9013.01.1.3	0,1	1,3	2,6	2,3	5,9	10	25	0,15	3	105123	Δ	▲		
L105.9013.01.2.3	0,1	1,3	2,6	2,3	5,9	15	30	0,15	3	105123	Δ	Δ		
L105.9013.01.3.3	0,1	1,3	2,6	2,3	5,9	20	35	0,15	3	105123	Δ	Δ		
L105.9013.1.3	0,2	1,3	2,6	2,3	5,9	10	25	0,15	3	105123	▲			▲
L105.9013.2.3	0,2	1,3	2,6	2,3	5,9	15	30	0,15	3	105123	▲			▲
L105.9019.01.1.4	0,1	1,9	3,7	2,9	6,4	10	25	0,3	4	105124	Δ	Δ		
L105.9019.01.2.4	0,1	1,9	3,7	2,9	6,4	15	30	0,3	4	105124	Δ	Δ		
L105.9019.01.3.4	0,1	1,9	3,7	2,9	6,4	20	35	0,3	4	105124	Δ	Δ		
L105.9019.1.4	0,2	1,9	3,7	2,9	6,4	10	25	0,3	4	105124	▲			▲
L105.9019.2.4	0,2	1,9	3,7	2,9	6,4	15	30	0,3	4	105124	▲			▲
P	●	●	●	●	●	●	●	●	●	●	●	●	●	●
M	●	●	●	●	●	●	●	●	●	●	●	●	●	●
K	○	●	●	●	●	●	●	●	●	●	●	●	●	●
N	-	●	●	●	●	●	●	●	●	●	●	●	●	●
S	-	●	●	●	●	●	●	●	●	●	●	●	●	●
H	-	-	-	-	-	-	-	-	-	-	-	-	-	-

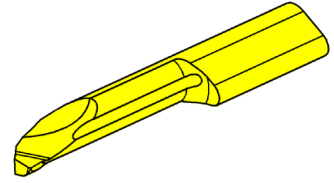
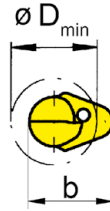
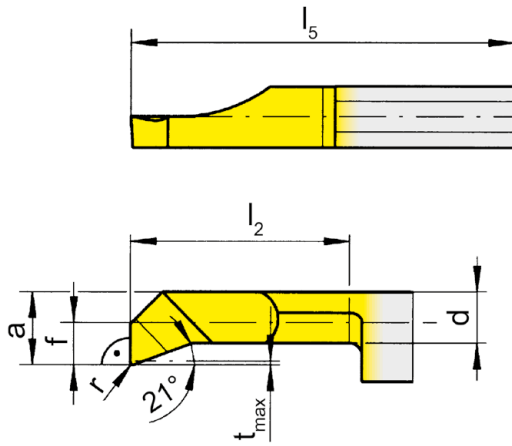
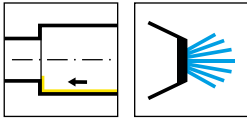

R = rechts wie gezeichnet
R = right hand version shown

L = links spiegelbildlich
L = left hand version

▲ ab Lager
on stock

HM-Sorten
Carbide grades
Δ 4 Wochen
4 weeks

Bestellnummer Part number	r	f	a	d	b	l ₂	l ₅	t _{max}	D _{min}	HIS	EG35	TH35	TN35
R105.9023.01.1.5	0,1	2,3	4,7	4	7	10	25	0,5	5	105125	Δ	▲	
R105.9023.01.2.5	0,1	2,3	4,7	4	7	15	30	0,5	5	105125	▲	▲	
R105.9023.01.3.5	0,1	2,3	4,7	4	7	20	35	0,5	5	105125	▲	▲	
R105.9023.01.4.5	0,1	2,3	4,7	4	7	25	40	0,5	5	105125	Δ	▲	
R105.9023.1.5	0,2	2,3	4,7	4	7	10	25	0,5	5	105125	▲	▲	▲
R105.9023.2.5	0,2	2,3	4,7	4	7	15	30	0,5	5	105125	▲	▲	▲
R105.9023.3.5	0,2	2,3	4,7	4	7	20	35	0,5	5	105125	▲		▲
R105.9033.1.6	0,2	3,3	5,7	4,7	7	10	25	0,5	6	105125	Δ	▲	
R105.9033.2.6	0,2	3,3	5,7	4,7	7	15	30	0,5	6	105125	Δ	▲	
R105.9033.3.6	0,2	3,3	5,7	4,7	7	20	35	0,5	6	105125	Δ	▲	
R105.9033.4.6	0,2	3,3	5,7	4,7	7	25	40	0,5	6	105125	Δ	▲	
R105.9033.5.6	0,2	3,3	5,7	4,7	7	30	45	0,5	6	105125	Δ	▲	
L105.9023.01.1.5	0,1	2,3	4,7	4	7	10	25	0,5	5	105125	Δ	Δ	
L105.9023.01.2.5	0,1	2,3	4,7	4	7	15	30	0,5	5	105125	Δ	▲	
L105.9023.01.3.5	0,1	2,3	4,7	4	7	20	35	0,5	5	105125	Δ	▲	
L105.9023.01.4.5	0,1	2,3	4,7	4	7	25	40	0,5	5	105125	Δ	Δ	
L105.9023.1.5	0,2	2,3	4,7	4	7	10	25	0,5	5	105125	▲		▲
L105.9023.2.5	0,2	2,3	4,7	4	7	15	30	0,5	5	105125	▲		▲
L105.9023.3.5	0,2	2,3	4,7	4	7	20	35	0,5	5	105125			▲
L105.9033.1.6	0,2	3,3	5,7	4,7	7	10	25	0,5	6	105125	Δ		
L105.9033.2.6	0,2	3,3	5,7	4,7	7	15	30	0,5	6	105125	Δ	Δ	
L105.9033.3.6	0,2	3,3	5,7	4,7	7	20	35	0,5	6	105125	Δ	▲	
L105.9033.4.6	0,2	3,3	5,7	4,7	7	25	40	0,5	6	105125	Δ	Δ	
L105.9033.5.6	0,2	3,3	5,7	4,7	7	30	45	0,5	6	105125	Δ	▲	
P	●	●	●										
M	●	●	●										
K	○	●	●										
N	-	●	●										
S	-	●	●										
H	-	-	-										

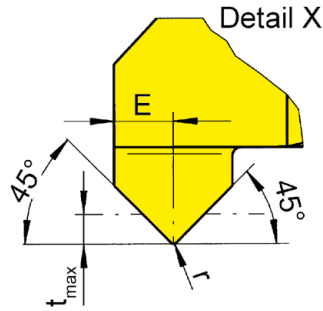
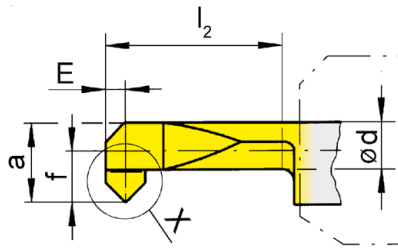
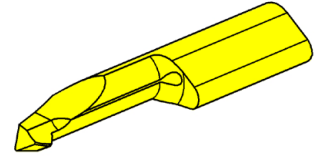
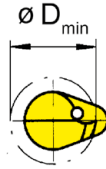
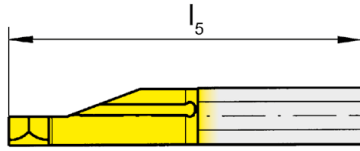
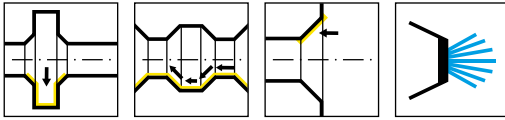

R = rechts wie gezeichnet
R = right hand version shown

L = links spiegelbildlich
L = left hand version

▲ ab Lager
on stock

HM-Sorten
Carbide grades
Δ 4 Wochen
4 weeks

Bestellnummer Part number	r	f	E	a	d	b	l ₂	l ₅	t _{max}	D _{min}	HIS	EG35	TF45	TI25	TN35
R105.4545.2.5	0,2	2,3	1	4,7	3,5	7	15	30	0,7	5	105125	▲			▲
R105.4545.3.7	0,2	4	1	6,4	4,7	7	20	35	0,7	7	105125	▲			▲
L105.4545.2.5	0,2	2,3	1	4,7	3,5	7	15	30	0,7	5	105125	▲			▲
L105.4545.3.7	0,2	4	1	6,4	4,7	7	20	35	0,7	7	105125	▲		Δ	▲
P	●	●	●	●	●	●	●	●	●	●		●	●	●	●
M	●	●	●	●	●	●	●	●	●	●		●	●	●	●
K	○	●	●	●	●	●	●	●	●	●		●	●	●	●
N	-	●	●	●	●	●	●	●	●	●		●	●	●	●
S	-	●	●	●	●	●	●	●	●	●		●	●	●	●
H	-	-	-	-	-	-	-	-	-	-		-	-	-	-

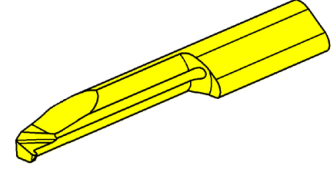
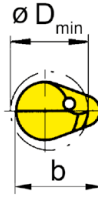
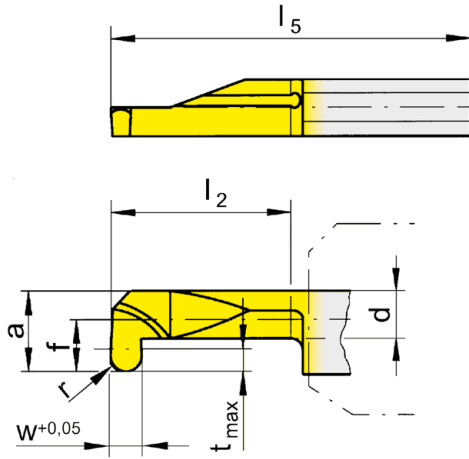
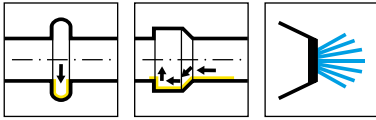

R = rechts wie gezeichnet
R = right hand version shown

L = links spiegelbildlich
L = left hand version

▲ ab Lager
on stock

HM-Sorten
Carbide grades
Δ 4 Wochen
4 weeks

Bestellnummer Part number	w	r	f	a	d	b	l ₂	l ₅	t _{max}	D _{min}	HIS	EG35	ES15	TH35	TN35
R105.0025.2.3	0,5	0,25	1,4	2,7	1,9	5,9	15	30	0,6	3	105123	▲	Δ		
R105.0005.1.4	1	0,5	1,9	3,7	2,7	6,4	10	25	0,8	4	105124	▲		▲	
R105.0005.2.4	1	0,5	1,9	3,7	2,7	6,4	15	30	0,8	4	105124	▲			▲
R105.0025.3.5	0,5	0,25	2,3	4,7	3,9	7	20	35	0,6	5	105125	▲	Δ		
R105.0005.3.5	1	0,5	2,3	4,7	3,5	7	20	35	1	5	105125	▲			▲
R105.0007.1.5	1,5	0,75	2,3	4,7	3,5	7	10	25	1	5	105125	Δ		▲	
R105.0007.3.5	1,5	0,75	2,3	4,7	3,5	7	20	35	1	5	105125	▲			▲
R105.0010.1.5	2	1	2,3	4,7	3,5	7	10	25	1	5	105125	▲		▲	
R105.0010.3.5	2	1	2,3	4,7	3,5	7	20	35	1	5	105125	▲			▲
L105.0005.1.4	1	0,5	1,9	3,7	2,7	6,4	10	25	0,8	4	105124	Δ		▲	
L105.0005.2.4	1	0,5	1,9	3,7	2,7	6,4	15	30	0,8	4	105124	▲			▲
L105.0005.3.5	1	0,5	2,3	4,7	3,5	7	20	35	1	5	105125	▲			▲
L105.0007.1.5	1,5	0,75	2,3	4,7	3,5	7	10	25	1	5	105125	Δ		Δ	
L105.0007.3.5	1,5	0,75	2,3	4,7	3,5	7	20	35	1	5	105125	Δ			▲
L105.0010.1.5	2	1	2,3	4,7	3,5	7	10	25	1	5	105125	Δ		Δ	
L105.0010.3.5	2	1	2,3	4,7	3,5	7	20	35	1	5	105125	Δ			▲
P	●	●	●	●	●	●	●	●	●	●		●	●	●	●
M	●	●	●	●	●	●	●	●	●	●		●	●	●	●
K	○	○	○	○	○	○	○	○	○	○		○	○	○	○
N	-	-	-	-	-	-	-	-	-	-		-	-	-	-
S	-	-	-	-	-	-	-	-	-	-		-	-	-	-
H	-	-	-	-	-	-	-	-	-	-		-	-	-	-

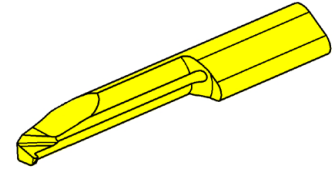
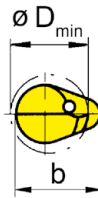
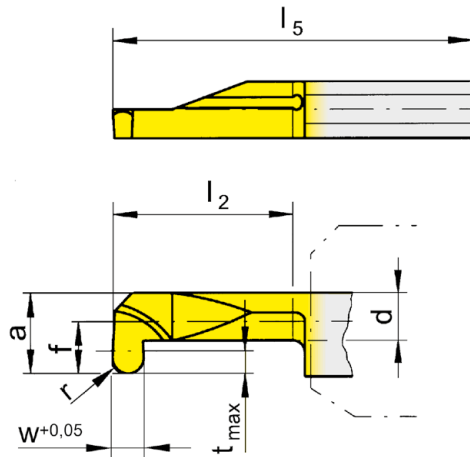
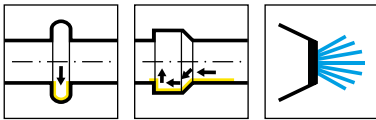

R = rechts wie gezeichnet
R = right hand version shown

L = links spiegelbildlich
L = left hand version

▲ ab Lager
on stock

HM-Sorten
Carbide grades
Δ 4 Wochen
4 weeks

Bestellnummer Part number	w	r	f	a	d	b	l ₂	l ₅	t _{max}	D _{min}	HIS	EG35	TH35	TN35	
R105.0005.2.6	1	0,5	3,3	5,7	3,7	7	15	30	1,8	6	105125	▲	▲		
R105.0007.2.6	1,5	0,75	3,3	5,7	3,7	7	15	30	1,8	6	105125	▲	▲		
R105.0010.2.6	2	1	3,3	5,7	3,7	7	15	30	1,8	6	105125	▲	▲		
R105.0005.4.6	1	0,5	3,3	5,7	3,7	7	25	40	1,8	6	105125	▲		▲	
R105.0007.4.6	1,5	0,75	3,3	5,7	3,7	7	25	40	1,8	6	105125	▲		▲	
R105.0010.4.6	2	1	3,3	5,7	3,7	7	25	40	1,8	6	105125	▲		▲	
L105.0005.2.6	1	0,5	3,3	5,7	3,7	7	15	30	1,8	6	105125	Δ	▲		
L105.0007.2.6	1,5	0,75	3,3	5,7	3,7	7	15	30	1,8	6	105125	Δ	Δ		
L105.0010.2.6	2	1	3,3	5,7	3,7	7	15	30	1,8	6	105125	Δ	Δ		
L105.0005.4.6	1	0,5	3,3	5,7	3,7	7	25	40	1,8	6	105125	Δ		▲	
L105.0007.4.6	1,5	0,75	3,3	5,7	3,7	7	25	40	1,8	6	105125	Δ		▲	
L105.0010.4.6	2	1	3,3	5,7	3,7	7	25	40	1,8	6	105125			▲	
												P	●	●	●
												M	●	●	●
												K	●	●	●
												N	-	●	●
												S	-	●	●
												H	-	-	-

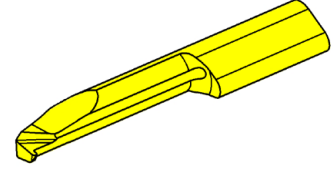
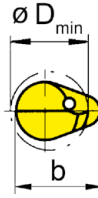
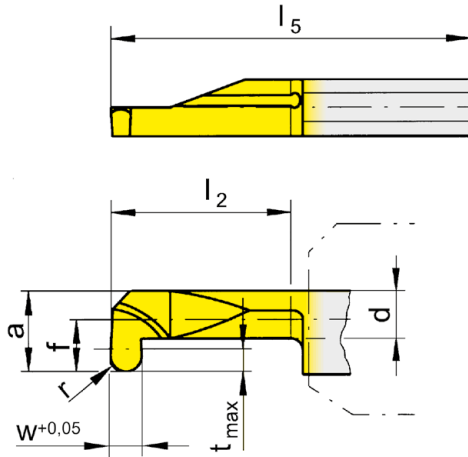
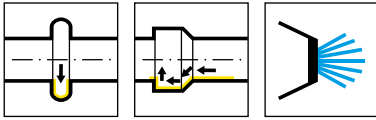

R = rechts wie gezeichnet
R = right hand version shown

L = links spiegelbildlich
L = left hand version

▲ ab Lager
on stock

HM-Sorten
Carbide grades
Δ 4 Wochen
4 weeks

Bestellnummer Part number	w	r	f	a	d	b	l ₂	l ₅	t _{max}	D _{min}	HIS	EG35	TH35	TN35
R105.0005.3.7	1	0,5	4	6,4	3,7	7	20	35	2,5	6,8	105125	▲	▲	
R105.0007.3.7	1,5	0,75	4	6,4	3,7	7	20	35	2,5	6,8	105125	Δ	▲	
R105.0010.3.7	2	1	4	6,4	3,7	7	20	35	2,5	6,8	105125	▲	▲	
R105.0005.5.7	1	0,5	4	6,4	3,7	7	30	45	2,5	6,8	105125	▲		▲
R105.0007.5.7	1,5	0,75	4	6,4	3,7	7	30	45	2,5	6,8	105125	▲		▲
R105.0010.5.7	2	1	4	6,4	3,7	7	30	45	2,5	6,8	105125	▲		▲
L105.0005.3.7	1	0,5	4	6,4	3,7	7	20	35	2,5	6,8	105125	Δ	▲	
L105.0007.3.7	1,5	0,75	4	6,4	3,7	7	20	35	2,5	6,8	105125	Δ	▲	
L105.0010.3.7	2	1	4	6,4	3,7	7	20	35	2,5	6,8	105125	Δ	▲	
L105.0005.5.7	1	0,5	4	6,4	3,7	7	30	45	2,5	6,8	105125	Δ		▲
L105.0007.5.7	1,5	0,75	4	6,4	3,7	7	30	45	2,5	6,8	105125	Δ		▲
L105.0010.5.7	2	1	4	6,4	3,7	7	30	45	2,5	6,8	105125	Δ		▲
P	●	●	●											
M	●	●	●											
K	○	●	●											
N	-	●	●											
S	-	●	●											
H	-	-	-											

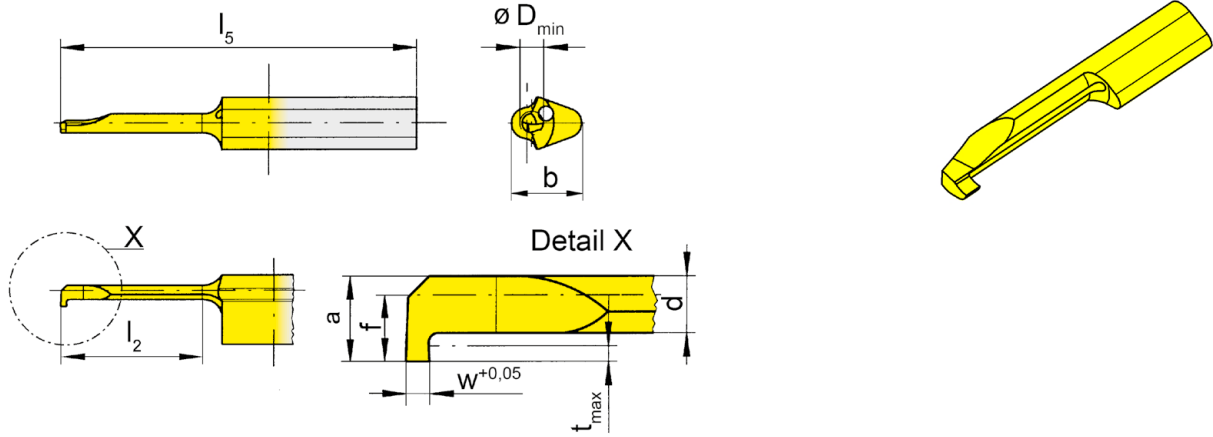
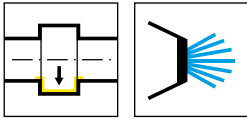

R = rechts wie gezeichnet
R = right hand version shown

L = links spiegelbildlich
L = left hand version

▲ ab Lager
on stock

HM-Sorten
Carbide grades
Δ 4 Wochen
4 weeks

Bestellnummer Part number	w	f	a	d	b	l_2	l_5	t_{max}	D_{min}	HIS		EG35	T125
R105.0050.0.2	0,5	1,4	1,8	1,2	5,9	6	25	0,4	2	105123	▲	▲	▲
R105.0050.1.2	0,5	1,4	1,8	1,2	5,9	9	25	0,4	2	105123	▲	▲	▲
R105.0050.2.2	0,5	1,4	1,8	1,2	5,9	12	30	0,4	2	105123	▲	▲	▲
L105.0050.0.2	0,5	1,4	1,8	1,2	5,9	6	25	0,4	2	105123	▲	▲	▲
L105.0050.1.2	0,5	1,4	1,8	1,2	5,9	9	25	0,4	2	105123	Δ	▲	▲
L105.0050.2.2	0,5	1,4	1,8	1,2	5,9	12	30	0,4	2	105123	Δ	Δ	Δ
											P	●	●
											M	●	●
											K	○	●
											N	-	●
											S	-	●
											H	-	-

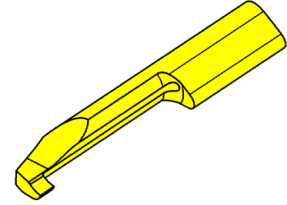
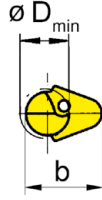
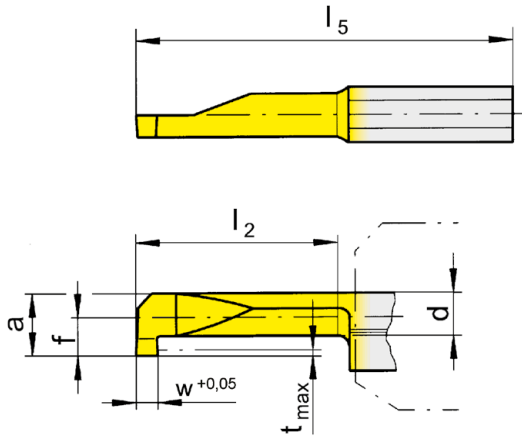
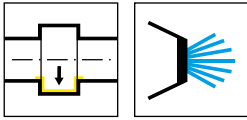

R = rechts wie gezeichnet
R = right hand version shown

L = links spiegelbildlich
L = left hand version

▲ ab Lager
on stock

HM-Sorten
Carbide grades
Δ 4 Wochen
4 weeks

Bestellnummer Part number	w	f	a	d	b	l ₂	l ₅	t _{max}	D _{min}	HIS		MG12	EG35	ES15	TI25
R105.0050.1.3	0,5	1,4	2,7	2	5,9	8	25	0,5	3	105123			▲	Δ	
R105.0050.2.3	0,5	1,4	2,7	2	5,9	12	30	0,5	3	105123		Δ	Δ	Δ	
R105.0050.3.3	0,5	1,4	2,7	2	5,9	16	35	0,5	3	105123			Δ	Δ	
R105.0070.1.3	0,7	1,4	2,7	1,9	5,9	8	25	0,6	3	105123			▲		▲
R105.0070.2.3	0,7	1,4	2,7	1,9	5,9	12	30	0,6	3	105123			▲		▲
R105.0070.3.3	0,7	1,4	2,7	1,9	5,9	16	35	0,6	3	105123			▲		▲
L105.0070.1.3	0,7	1,4	2,7	1,9	5,9	8	25	0,6	3	105123			▲		▲
L105.0070.2.3	0,7	1,4	2,7	1,9	5,9	12	30	0,6	3	105123			Δ		▲
L105.0070.3.3	0,7	1,4	2,7	1,9	5,9	16	35	0,6	3	105123			Δ		▲
												P	o	•	•
												M	-	•	•
												K	-	o	o
												N	-	-	•
												S	-	-	•
												H	-	-	-

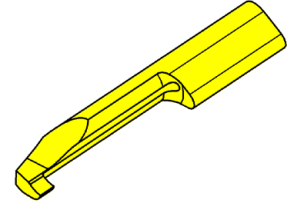
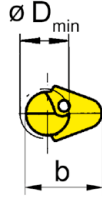
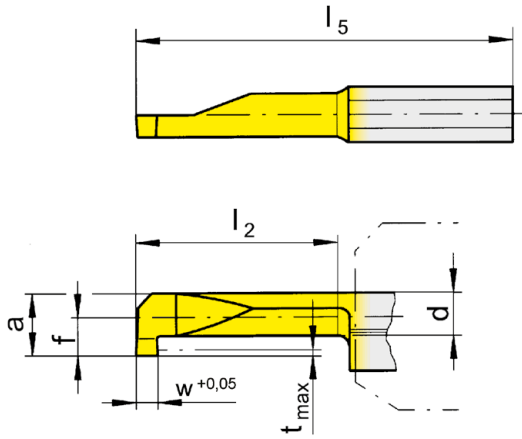
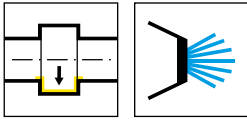

R = rechts wie gezeichnet
R = right hand version shown

L = links spiegelbildlich
L = left hand version

▲ ab Lager
on stock

HM-Sorten
Carbide grades
Δ 4 Wochen
4 weeks

Bestellnummer Part number	w	f	a	d	b	l ₂	l ₅	t _{max}	D _{min}	HIS	MG12	EG35	ES15	TN35
R105.0050.1.4	0,5	1,9	3,7	2,9	6,4	10	25	0,6	4	105124		▲	▲	
R105.0050.2.4	0,5	1,9	3,7	2,9	6,4	15	30	0,6	4	105124		▲		
R105.0050.3.4	0,5	1,9	3,7	2,9	6,4	20	35	0,6	4	105124		Δ	Δ	
R105.0100.1.4	1	1,9	3,7	2,7	6,4	10	25	0,8	4	105124	▲	▲		▲
R105.0100.2.4	1	1,9	3,7	2,7	6,4	15	30	0,8	4	105124	▲	▲		▲
R105.0100.3.4	1	1,9	3,7	2,7	6,4	20	35	0,8	4	105124	▲	Δ		▲
L105.0100.1.4	1	1,9	3,7	2,7	6,4	10	25	0,8	4	105124	▲	Δ		▲
L105.0100.2.4	1	1,9	3,7	2,7	6,4	15	30	0,8	4	105124	Δ	Δ		▲
L105.0100.3.4	1	1,9	3,7	2,7	6,4	20	35	0,8	4	105124	Δ	Δ		▲
P	o	•	•	•										
M	-	•	•	•										
K	-	o	o	•										
N	-	-	-	•										
S	-	-	-	•										
H	-	-	-	-										

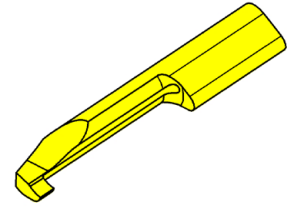
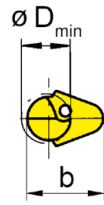
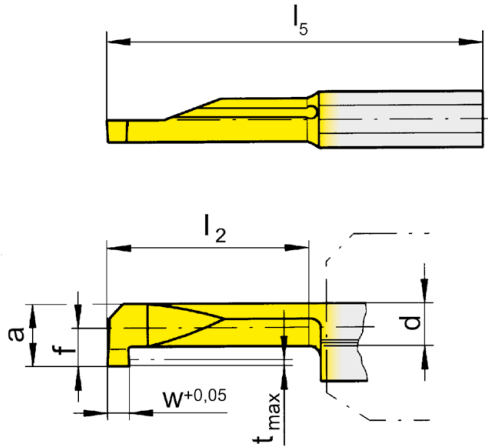
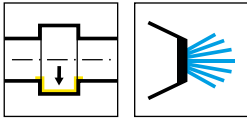

R = rechts wie gezeichnet
R = right hand version shown

L = links spiegelbildlich
L = left hand version

▲ ab Lager
on stock

HM-Sorten
Carbide grades
Δ 4 Wochen
4 weeks

Bestellnummer Part number	w	f	a	d	b	l ₂	l ₅	t _{max}	D _{min}	HIS	MG12	EG35	TH35	TN35
R105.0100.1.5	1	2,3	4,7	3,5	7	10	25	1	5	105125	▲	▲	▲	▲
R105.0150.1.5	1,5	2,3	4,7	3,5	7	10	25	1	5	105125	▲	▲	▲	▲
R105.0200.1.5	2	2,3	4,7	3,5	7	10	25	1	5	105125	▲	▲	▲	▲
R105.0100.2.5	1	2,3	4,7	3,5	7	15	30	1	5	105125	▲	▲	▲	▲
R105.0150.2.5	1,5	2,3	4,7	3,5	7	15	30	1	5	105125	▲	▲	▲	▲
R105.0200.2.5	2	2,3	4,7	3,5	7	15	30	1	5	105125	▲	▲	▲	▲
R105.0100.3.5	1	2,3	4,7	3,5	7	20	35	1	5	105125	▲	▲	▲	▲
R105.0150.3.5	1,5	2,3	4,7	3,5	7	20	35	1	5	105125	▲	▲	▲	▲
R105.0200.3.5	2	2,3	4,7	3,5	7	20	35	1	5	105125	Δ	▲	▲	▲
L105.0100.1.5	1	2,3	4,7	3,5	7	10	25	1	5	105125	Δ	▲	▲	▲
L105.0150.1.5	1,5	2,3	4,7	3,5	7	10	25	1	5	105125	Δ	Δ	Δ	▲
L105.0200.1.5	2	2,3	4,7	3,5	7	10	25	1	5	105125	Δ	Δ	▲	▲
L105.0100.2.5	1	2,3	4,7	3,5	7	15	30	1	5	105125	Δ	Δ	Δ	▲
L105.0150.2.5	1,5	2,3	4,7	3,5	7	15	30	1	5	105125	Δ	Δ	Δ	▲
L105.0200.2.5	2	2,3	4,7	3,5	7	15	30	1	5	105125	Δ	Δ	▲	▲
L105.0100.3.5	1	2,3	4,7	3,5	7	20	35	1	5	105125	Δ	Δ	Δ	▲
L105.0150.3.5	1,5	2,3	4,7	3,5	7	20	35	1	5	105125	Δ	Δ	Δ	▲
L105.0200.3.5	2	2,3	4,7	3,5	7	20	35	1	5	105125	Δ	Δ	Δ	Δ
P	o	●	●	●										
M	-	●	●	●										
K	-	o	●	●										
N	-	-	●	●										
S	-	-	●	●										
H	-	-	-	-										

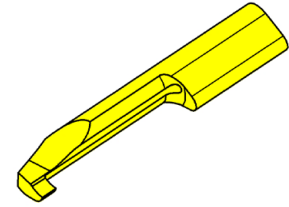
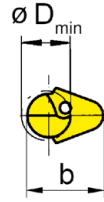
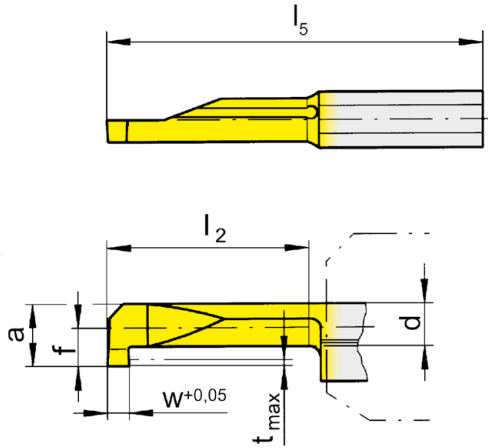
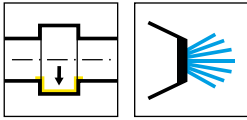

R = rechts wie gezeichnet
R = right hand version shown

L = links spiegelbildlich
L = left hand version

▲ ab Lager
on stock

HM-Sorten
Carbide grades
Δ 4 Wochen
4 weeks

Bestellnummer Part number	w	f	a	d	b	l_2	l_5	t_{max}	D_{min}	HIS	EG35	TH35	TN35
R105.0100.4.5	1	2,3	4,7	3,5	7	25	40	1	5	105125	▲	Δ	▲
R105.0150.4.5	1,5	2,3	4,7	3,5	7	25	40	1	5	105125		▲	▲
R105.0200.4.5	2	2,3	4,7	3,5	7	25	40	1	5	105125	▲	▲	▲
R105.0100.5.5	1	2,3	4,7	3,5	7	30	45	1	5	105125	▲	▲	▲
R105.0150.5.5	1,5	2,3	4,7	3,5	7	30	45	1	5	105125	Δ	▲	▲
R105.0200.5.5	2	2,3	4,7	3,5	7	30	45	1	5	105125	Δ	▲	▲
L105.0100.4.5	1	2,3	4,7	3,5	7	25	40	1	5	105125	Δ	Δ	Δ
L105.0150.4.5	1,5	2,3	4,7	3,5	7	25	40	1	5	105125	Δ	Δ	Δ
L105.0200.4.5	2	2,3	4,7	3,5	7	25	40	1	5	105125	Δ	Δ	Δ
L105.0100.5.5	1	2,3	4,7	3,5	7	30	45	1	5	105125	Δ	Δ	Δ
L105.0150.5.5	1,5	2,3	4,7	3,5	7	30	45	1	5	105125	Δ	Δ	Δ
L105.0200.5.5	2	2,3	4,7	3,5	7	30	45	1	5	105125	Δ	Δ	Δ
P											●	●	●
M											●	●	●
K											○	●	●
N											-	●	●
S											-	●	●
H											-	-	-

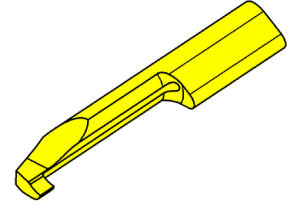
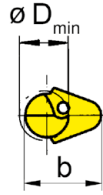
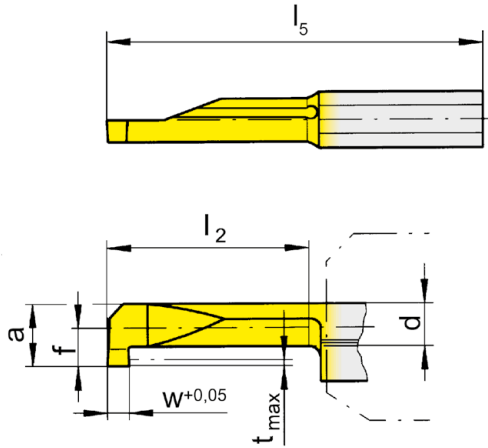
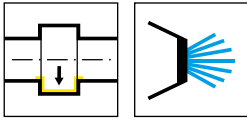

R = rechts wie gezeichnet
R = right hand version shown

L = links spiegelbildlich
L = left hand version

▲ ab Lager
on stock

HM-Sorten
Carbide grades
Δ 4 Wochen
4 weeks

Bestellnummer Part number	w	f	a	d	b	l ₂	l ₅	t _{max}	D _{min}	HIS		MG12	EG35	TH35	TN35
R105.0100.1.6	1	3,3	5,7	3,7	7	10	25	1,8	6	105125	▲	▲	▲	▲	
R105.0150.1.6	1,5	3,3	5,7	3,7	7	10	25	1,8	6	105125	▲	▲	▲	▲	
R105.0200.1.6	2	3,3	5,7	3,7	7	10	25	1,8	6	105125	▲	▲	▲	▲	
R105.0100.2.6	1	3,3	5,7	3,7	7	15	30	1,8	6	105125	▲	▲	▲	▲	
R105.0150.2.6	1,5	3,3	5,7	3,7	7	15	30	1,8	6	105125	▲	▲	▲	▲	
R105.0200.2.6	2	3,3	5,7	3,7	7	15	30	1,8	6	105125	▲	▲	▲	▲	
R105.0100.3.6	1	3,3	5,7	3,7	7	20	35	1,8	6	105125	▲	▲	▲	▲	
R105.0150.3.6	1,5	3,3	5,7	3,7	7	20	35	1,8	6	105125	▲	▲	▲	▲	
R105.0200.3.6	2	3,3	5,7	3,7	7	20	35	1,8	6	105125	▲	▲	▲	▲	
L105.0100.1.6	1	3,3	5,7	3,7	7	10	25	1,8	6	105125	▲	▲	▲	▲	
L105.0150.1.6	1,5	3,3	5,7	3,7	7	10	25	1,8	6	105125	Δ	▲	▲	▲	
L105.0200.1.6	2	3,3	5,7	3,7	7	10	25	1,8	6	105125	Δ	▲	▲	▲	
L105.0100.2.6	1	3,3	5,7	3,7	7	15	30	1,8	6	105125	Δ	Δ	▲	▲	
L105.0150.2.6	1,5	3,3	5,7	3,7	7	15	30	1,8	6	105125	Δ	▲	▲	▲	
L105.0200.2.6	2	3,3	5,7	3,7	7	15	30	1,8	6	105125	Δ	▲	▲	▲	
L105.0100.3.6	1	3,3	5,7	3,7	7	20	35	1,8	6	105125	Δ	Δ	▲	▲	
L105.0150.3.6	1,5	3,3	5,7	3,7	7	20	35	1,8	6	105125	Δ	Δ	▲	▲	
L105.0200.3.6	2	3,3	5,7	3,7	7	20	35	1,8	6	105125	Δ	▲	▲	▲	
P	o	●	●	●											
M	-	●	●	●											
K	-	o	●	●											
N	-	-	●	●											
S	-	-	●	●											
H	-	-	-	-											

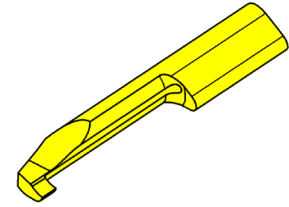
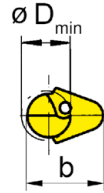
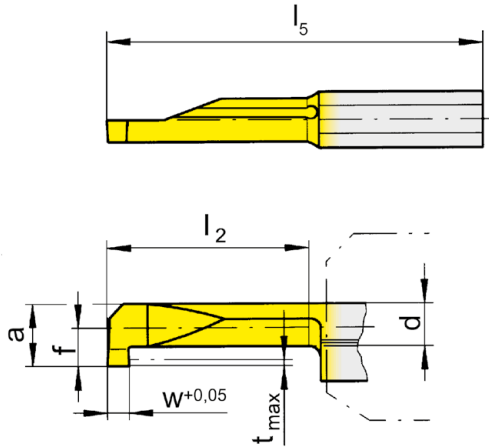
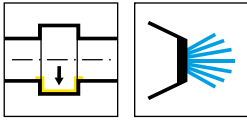

R = rechts wie gezeichnet
R = right hand version shown

L = links spiegelbildlich
L = left hand version

▲ ab Lager
on stock

HM-Sorten
Carbide grades
Δ 4 Wochen
4 weeks

Bestellnummer Part number	w	f	a	d	b	l_2	l_5	t_{max}	D_{min}	HIS	EG35	TH35	TN35
R105.0100.4.6	1	3,3	5,7	3,7	7	25	40	1,8	6	105125	▲	▲	▲
R105.0150.4.6	1,5	3,3	5,7	3,7	7	25	40	1,8	6	105125	▲	▲	▲
R105.0200.4.6	2	3,3	5,7	3,7	7	25	40	1,8	6	105125	▲	▲	▲
R105.0100.5.6	1	3,3	5,7	3,7	7	30	45	1,8	6	105125	▲	▲	▲
R105.0150.5.6	1,5	3,3	5,7	3,7	7	30	45	1,8	6	105125	▲	▲	▲
R105.0200.5.6	2	3,3	5,7	3,7	7	30	45	1,8	6	105125	▲	▲	▲
L105.0100.4.6	1	3,3	5,7	3,7	7	25	40	1,8	6	105125	Δ	▲	Δ
L105.0150.4.6	1,5	3,3	5,7	3,7	7	25	40	1,8	6	105125	Δ	Δ	▲
L105.0200.4.6	2	3,3	5,7	3,7	7	25	40	1,8	6	105125		Δ	▲
L105.0100.5.6	1	3,3	5,7	3,7	7	30	45	1,8	6	105125	Δ	Δ	Δ
L105.0150.5.6	1,5	3,3	5,7	3,7	7	30	45	1,8	6	105125	Δ	Δ	▲
L105.0200.5.6	2	3,3	5,7	3,7	7	30	45	1,8	6	105125	Δ	Δ	▲
P											●	●	●
M											●	●	●
K											○	●	●
N											-	●	●
S											-	●	●
H											-	-	-

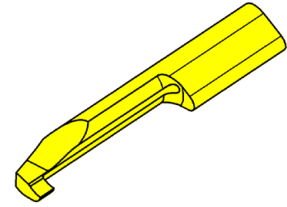
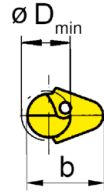
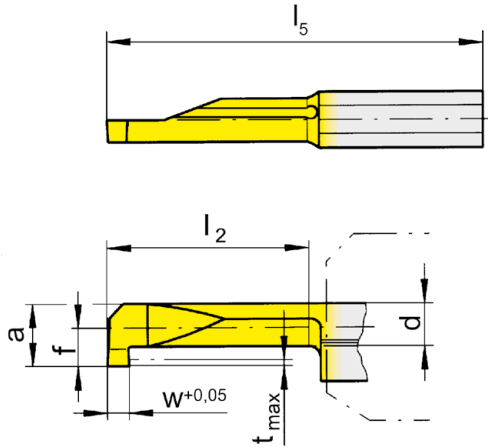
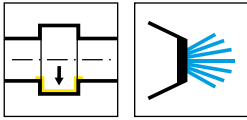

R = rechts wie gezeichnet
R = right hand version shown

L = links spiegelbildlich
L = left hand version

▲ ab Lager
on stock

HM-Sorten
Carbide grades
Δ 4 Wochen
4 weeks

Bestellnummer Part number	w	f	a	d	b	l ₂	l ₅	t _{max}	D _{min}	HIS	MG12	EG35	TH35	TN35
R105.0100.1.7	1	4	6,4	3,7	7	10	25	2,5	6,8	105125	▲	▲	▲	▲
R105.0150.1.7	1,5	4	6,4	3,7	7	10	25	2,5	6,8	105125	▲	▲	▲	▲
R105.0200.1.7	2	4	6,4	3,7	7	10	25	2,5	6,8	105125	▲	▲	▲	▲
R105.0100.2.7	1	4	6,4	3,7	7	15	30	2,5	6,8	105125	▲	▲	▲	▲
R105.0150.2.7	1,5	4	6,4	3,7	7	15	30	2,5	6,8	105125	▲	▲	▲	▲
R105.0200.2.7	2	4	6,4	3,7	7	15	30	2,5	6,8	105125	▲	▲	▲	▲
R105.0100.3.7	1	4	6,4	3,7	7	20	35	2,5	6,8	105125	▲	▲	▲	▲
R105.0150.3.7	1,5	4	6,4	3,7	7	20	35	2,5	6,8	105125	▲	▲	▲	▲
R105.0200.3.7	2	4	6,4	3,7	7	20	35	2,5	6,8	105125	▲	▲	▲	▲
L105.0100.1.7	1	4	6,4	3,7	7	10	25	2,5	6,8	105125	▲	Δ	▲	▲
L105.0150.1.7	1,5	4	6,4	3,7	7	10	25	2,5	6,8	105125	▲	▲	▲	▲
L105.0200.1.7	2	4	6,4	3,7	7	10	25	2,5	6,8	105125	▲	▲	▲	▲
L105.0100.2.7	1	4	6,4	3,7	7	15	30	2,5	6,8	105125	Δ	▲	▲	▲
L105.0150.2.7	1,5	4	6,4	3,7	7	15	30	2,5	6,8	105125	▲	▲	▲	▲
L105.0200.2.7	2	4	6,4	3,7	7	15	30	2,5	6,8	105125	▲	Δ	▲	▲
L105.0100.3.7	1	4	6,4	3,7	7	20	35	2,5	6,8	105125	▲	▲	▲	▲
L105.0150.3.7	1,5	4	6,4	3,7	7	20	35	2,5	6,8	105125	Δ	▲	▲	▲
L105.0200.3.7	2	4	6,4	3,7	7	20	35	2,5	6,8	105125	Δ	Δ	▲	▲
P	o	●	●	●										
M	-	●	●	●										
K	-	o	●	●										
N	-	-	●	●										
S	-	-	●	●										
H	-	-	-	-										

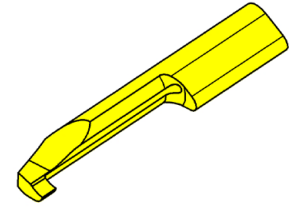
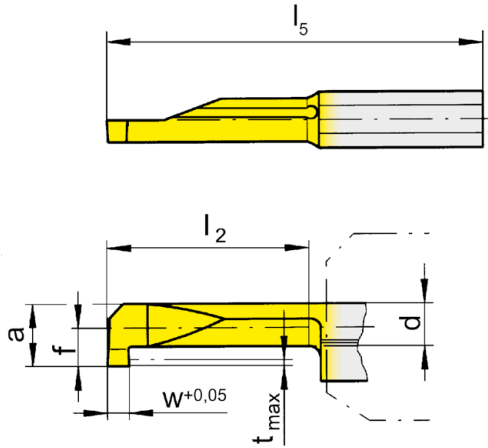
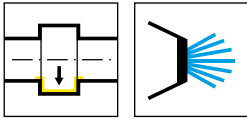

R = rechts wie gezeichnet
R = right hand version shown

L = links spiegelbildlich
L = left hand version

▲ ab Lager
on stock

HM-Sorten
Carbide grades
Δ 4 Wochen
4 weeks

Bestellnummer Part number	w	f	a	d	b	l ₂	l ₅	t _{max}	D _{min}	HIS	EG35	TH35	TN35
R105.0100.4.7	1	4	6,4	3,7	7	25	40	2,5	6,8	105125	▲	▲	▲
R105.0150.4.7	1,5	4	6,4	3,7	7	25	40	2,5	6,8	105125	▲	▲	▲
R105.0200.4.7	2	4	6,4	3,7	7	25	40	2,5	6,8	105125	▲	▲	▲
R105.0100.5.7	1	4	6,4	3,7	7	30	45	2,5	6,8	105125	Δ	▲	▲
R105.0150.5.7	1,5	4	6,4	3,7	7	30	45	2,5	6,8	105125	▲	▲	▲
R105.0200.5.7	2	4	6,4	3,7	7	30	45	2,5	6,8	105125	▲	▲	▲
L105.0100.4.7	1	4	6,4	3,7	7	25	40	2,5	6,8	105125	Δ	Δ	▲
L105.0150.4.7	1,5	4	6,4	3,7	7	25	40	2,5	6,8	105125	Δ	▲	▲
L105.0200.4.7	2	4	6,4	3,7	7	25	40	2,5	6,8	105125	Δ	▲	▲
L105.0100.5.7	1	4	6,4	3,7	7	30	45	2,5	6,8	105125	Δ	▲	▲
L105.0150.5.7	1,5	4	6,4	3,7	7	30	45	2,5	6,8	105125	Δ	▲	▲
L105.0200.5.7	2	4	6,4	3,7	7	30	45	2,5	6,8	105125	Δ	▲	▲
P											●	●	●
M											●	●	●
K											○	●	●
N											-	●	●
S											-	●	●
H											-	-	-

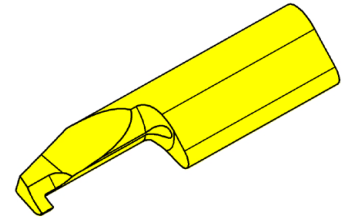
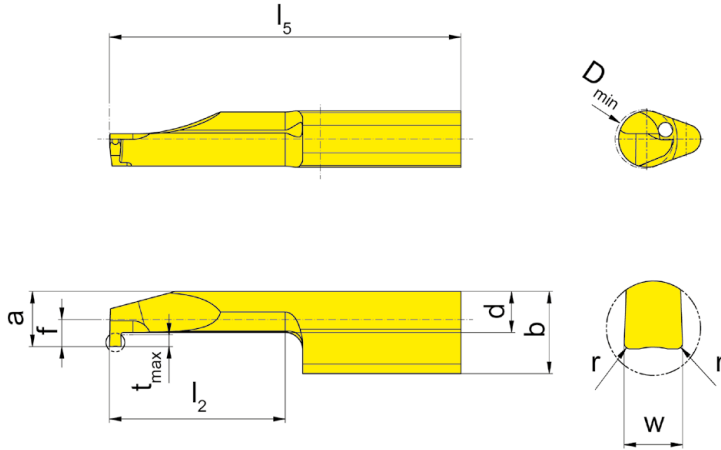

R = rechts wie gezeichnet
R = right hand version shown

L = links spiegelbildlich
L = left hand version

▲ ab Lager
on stock

HM-Sorten
Carbide grades
Δ 4 Wochen
4 weeks

Bestellnummer Part number	w	r	f	a	d	b	l ₂	l ₅	t _{max}	D _{min}	HIS	EG35
R105.FB10.1.01	1	0,1	2,3	4,7	3,5	7	10	25	1	5	105125	▲
R105.FB10.2.01	1	0,1	2,3	4,7	3,5	7	15	30	1	5	105125	▲
R105.FB15.1.01	1,5	0,1	2,3	4,7	3,5	7	10	25	1	5	105125	▲
R105.FB15.2.01	1,5	0,1	2,3	4,7	3,5	7	15	30	1	5	105125	▲
L105.FB10.1.01	1	0,1	2,3	4,7	3,5	7	10	25	1	5	105125	▲
L105.FB10.2.01	1	0,1	2,3	4,7	3,5	7	15	30	1	5	105125	▲
L105.FB15.1.01	1,5	0,1	2,3	4,7	3,5	7	10	25	1	5	105125	▲
L105.FB15.2.01	1,5	0,1	2,3	4,7	3,5	7	15	30	1	5	105125	▲

Berechnung der kleinstmöglichen Nutbreite w_x
Calculation of the smallest possible width of groove w_x

Beispiel R105.FB10.01
Example

w_x = 2 x Schneidbreite w - 2 x Eckenradius Schneidplatte R

w_x = 2 x Width of insert w - 2 x Corner radius insert R

w_x = 2 x 1 mm - 2 x 0,1 mm

w_x = 1,8 mm

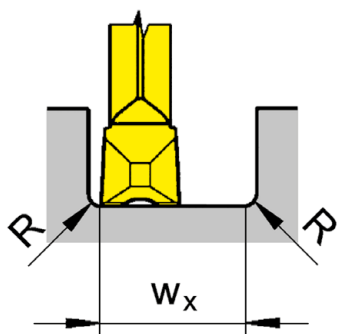

Bearbeitungsablauf
Processing flow

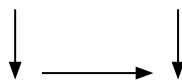

P	●
M	●
K	○
N	-
S	-
H	-

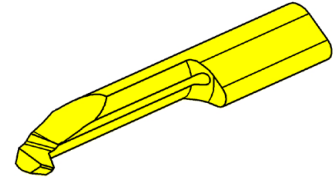
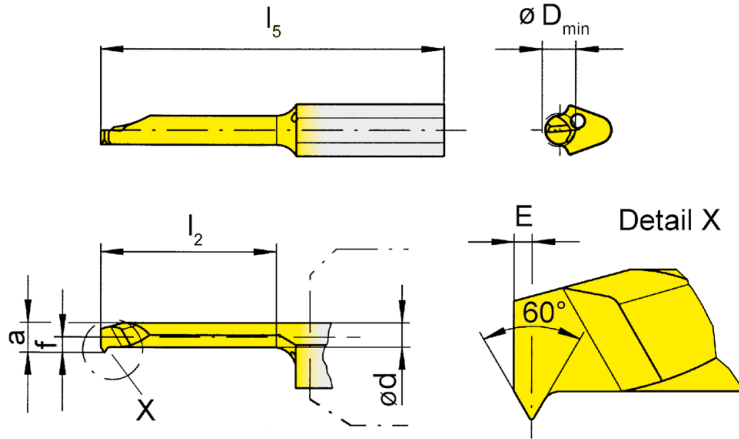
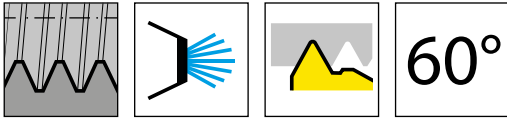

R = rechts wie gezeichnet
R = right hand version shown

L = links spiegelbildlich
L = left hand version

▲ ab Lager
on stock

HM-Sorten
Carbide grades
Δ 4 Wochen
4 weeks

Bestellnummer Part number	P	E	f	a	d	b	l_2	l_5	D_{min}	HIS	EG35	TN35
R105.0102.2.3	0,25	0,3	1,4	2,7	2,2	5,9	15	30	3	105123	Δ	▲
L105.0102.2.3	0,25	0,3	1,4	2,7	2,2	5,9	15	30	3	105123	Δ	▲
P	●	●										
M	●	●										
K	○	●										
N	-	●										
S	-	●										
H	-	-										

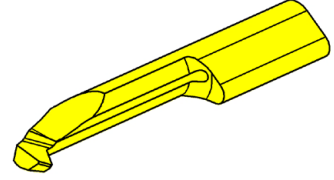
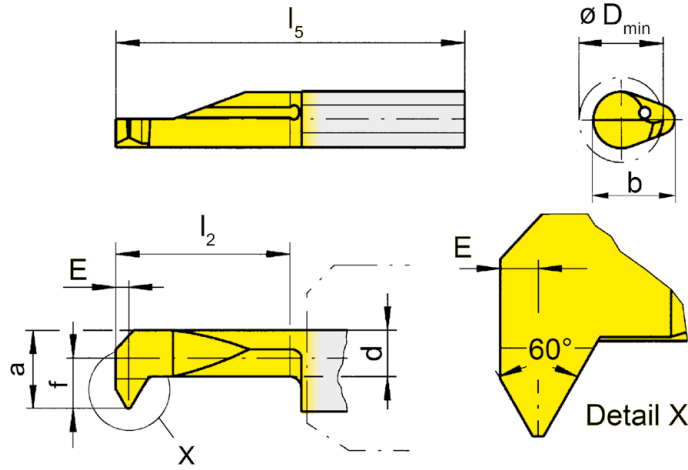
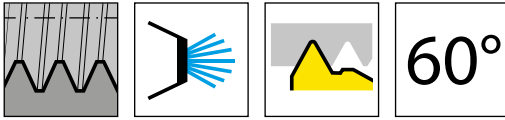

R = rechts wie gezeichnet
R = right hand version shown

L = links spiegelbildlich
L = left hand version

▲ ab Lager
on stock

HM-Sorten
Carbide grades
Δ 4 Wochen
4 weeks

Bestellnummer Part number	P	E	f	a	d	b	l_2	l_5	D_{min}	HIS	EG35	TN35
R105.0203.1.3	0,35	0,3	1,4	2,7	2,1	5,9	10	25	3	105123	▲	▲
R105.0203.2.5	0,35	0,3	2,3	4,7	3,5	7	15	30	5	105125	▲	▲
L105.0203.1.3	0,35	0,3	1,4	2,7	2,1	5,9	10	25	3	105123	Δ	Δ
L105.0203.2.5	0,35	0,3	2,3	4,7	3,5	7	15	30	5	105125		▲
	P	●	●									
	M	●	●									
	K	○	●									
	N	-	●									
	S	-	●									
	H	-	-									

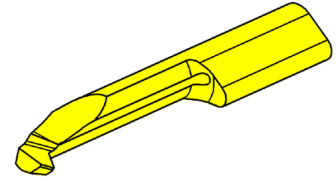
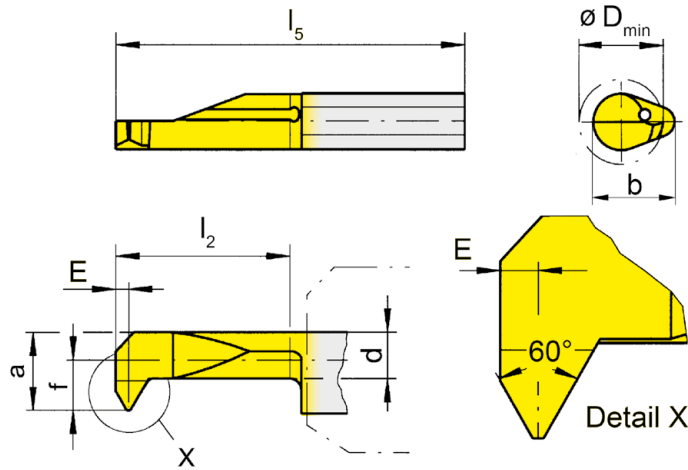
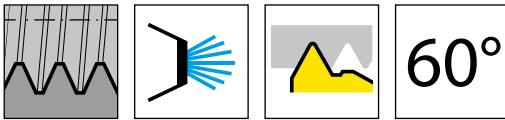

R = rechts wie gezeichnet
R = right hand version shown

L = links spiegelbildlich
L = left hand version

▲ ab Lager
on stock

HM-Sorten
Carbide grades
Δ 4 Wochen
4 weeks

Bestellnummer Part number	P	E	f	a	d	b	l ₂	l ₅	D _{min}	HIS	HM-Sorten Carbide grades			
											MG12	EG35	TH35	TN35
R105.0205.2.3	0,5	0,35	1,4	2,7	2,1	5,9	15	30	3	105123		▲		▲
R105.0205.2.4	0,5	0,35	1,9	3,7	2,7	6,4	15	30	4	105124		▲	▲	▲
R105.0205.3.4	0,5	0,35	1,9	3,7	2,7	6,4	20	35	4	105124		▲		▲
R105.0205.2.5	0,5	0,35	2,3	4,7	3,5	7	15	30	5	105125	▲	▲	▲	▲
R105.0205.3.5	0,5	0,35	2,3	4,7	3,5	7	20	35	5	105125		Δ		▲
R105.0205.4.5	0,5	0,35	2,3	4,7	3,5	7	25	40	5	105125				▲
R105.0205.3.6	0,5	0,35	3,3	5,7	4,8	7	20	35	6	105125		▲		▲
L105.0205.2.3	0,5	0,35	1,4	2,7	2,1	5,9	15	30	3	105123			Δ	▲
L105.0205.2.4	0,5	0,35	1,9	3,7	2,7	6,4	15	30	4	105124			Δ	▲
L105.0205.3.4	0,5	0,35	1,9	3,7	2,7	6,4	20	35	4	105124			Δ	Δ
L105.0205.2.5	0,5	0,35	2,3	4,7	3,5	7	15	30	5	105125		Δ	Δ	▲
L105.0205.3.5	0,5	0,35	2,3	4,7	3,5	7	20	35	5	105125			Δ	Δ
L105.0205.4.5	0,5	0,35	2,3	4,7	3,5	7	25	40	5	105125			Δ	Δ
L105.0205.3.6	0,5	0,35	3,3	5,7	4,8	7	20	35	6	105125			Δ	Δ
	P	o	•	•	•	•								
	M	-	•	•	•	•								
	K	-	o	•	•	•								
	N	-	-	•	•	•								
	S	-	-	•	•	•								
	H	-	-	-	-	-								

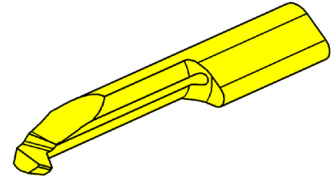
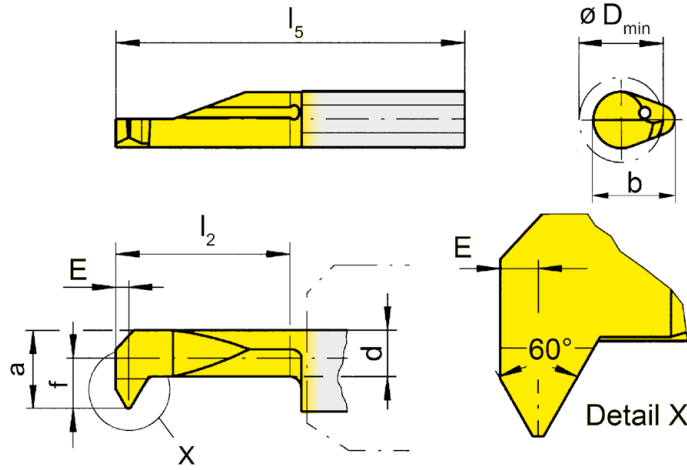
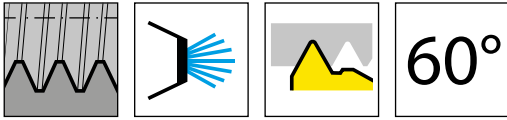

R = rechts wie gezeichnet
R = right hand version shown

L = links spiegelbildlich
L = left hand version

▲ ab Lager
on stock

HM-Sorten
Carbide grades
Δ 4 Wochen
4 weeks

Bestellnummer Part number	P	P _{max}	E	f	a	d	b	l ₂	l ₅	D _{min}	HIS	HM-Sorten Carbide grades		
												EG35	TH35	TN35
R105.0407.2.3	0,5	0,75	0,45	1,4	2,7	2	5,9	15	30	3	105123	▲		▲
R105.0407.1.4	0,5	0,75	0,45	1,9	3,7	2,7	6,4	10	25	4	105124	▲		▲
R105.0407.2.4	0,5	0,75	0,45	1,9	3,7	2,7	6,4	15	30	4	105124	▲		▲
R105.0407.3.4	0,5	0,75	0,45	1,9	3,7	2,7	6,4	20	35	4	105124	▲		▲
R105.0407.2.5	0,5	0,75	0,45	2,3	4,7	3,5	7	15	30	5	105125	▲	▲	▲
R105.0407.3.5	0,5	0,75	0,45	2,3	4,7	3,5	7	20	35	5	105125	Δ		▲
R105.0407.4.5	0,5	0,75	0,45	2,3	4,7	3,5	7	25	40	5	105125	▲		▲
R105.0407.3.6	0,5	0,75	0,45	3,3	5,7	4,7	7	20	35	6	105125	▲		▲
L105.0407.2.3	0,5	0,75	0,45	1,4	2,7	2	5,9	15	30	3	105123	Δ		Δ
L105.0407.1.4	0,5	0,75	0,45	1,9	3,7	2,7	6,4	10	25	4	105124	Δ		▲
L105.0407.2.4	0,5	0,75	0,45	1,9	3,7	2,7	6,4	15	30	4	105124	Δ		▲
L105.0407.3.4	0,5	0,75	0,45	1,9	3,7	2,7	6,4	20	35	4	105124	Δ		Δ
L105.0407.2.5	0,5	0,75	0,45	2,3	4,7	3,5	7	15	30	5	105125	▲	▲	▲
L105.0407.3.5	0,5	0,75	0,45	2,3	4,7	3,5	7	20	35	5	105125	Δ		Δ
L105.0407.4.5	0,5	0,75	0,45	2,3	4,7	3,5	7	25	40	5	105125	Δ		Δ
L105.0407.3.6	0,5	0,75	0,45	3,3	5,7	4,7	7	20	35	6	105125	Δ		Δ
P	●	●	●											
M	●	●	●											
K	○	●	●											
N	-	●	●											
S	-	●	●											
H	-	-	-											

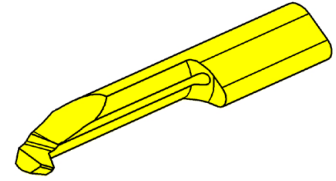
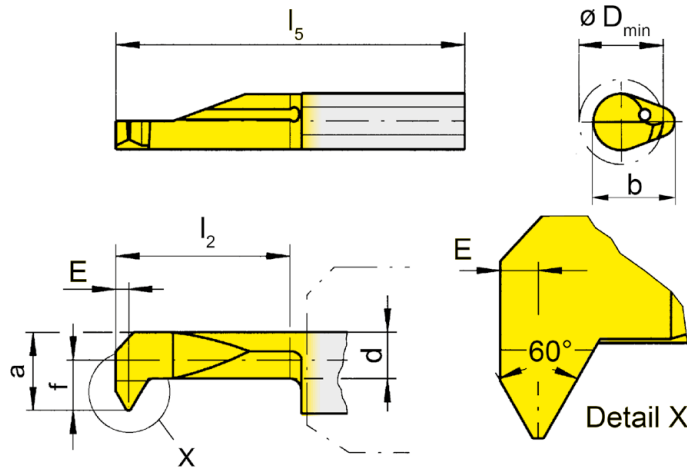
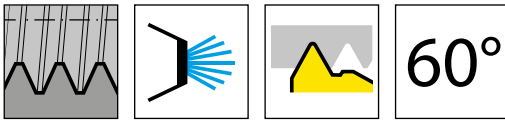

R = rechts wie gezeichnet
R = right hand version shown

L = links spiegelbildlich
L = left hand version

▲ ab Lager
on stock

HM-Sorten
Carbide grades
Δ 4 Wochen
4 weeks

Bestellnummer Part number	P	P _{max}	E	f	a	d	b	l ₂	l ₅	D _{min}	HIS	MG12	EG35	TF45	TH35	TI25	TN35
R105.0510.2.5	1	1	0,55	2,1	4,5	3,5	7	15	30	4,8	105125	▲	▲		▲	Δ	▲
R105.0510.3.5	1	1	0,55	2,1	4,5	3,5	7	20	35	4,8	105125		▲				▲
R105.0510.4.5	1	1	0,55	2,1	4,5	3,5	7	25	40	4,8	105125		▲				▲
R105.0510.2.6	1	1	0,55	3,3	5,7	3,7	7	15	30	6	105125		▲		▲		▲
R105.0612.2.6	1,25	1,25	0,65	3,3	5,7	3,7	7	15	30	6	105125	Δ	▲		▲		▲
R105.0612.3.6	1,25	1,25	0,65	3,3	5,7	3,7	7	20	35	6	105125		▲				▲
R105.0612.4.6	1,25	1,25	0,65	3,3	5,7	3,7	7	25	40	6	105125		▲				▲
R105.0815.2.7	1,5	1,5	0,75	4	6,4	3,7	7	15	30	7	105125		▲	Δ	▲		▲
R105.0815.3.7	1,5	1,5	0,75	4	6,4	3,7	7	20	35	7	105125		▲				▲
R105.0815.4.7	1,5	1,5	0,75	4	6,4	3,7	7	25	40	7	105125		▲				▲
L105.0510.2.5	1	1	0,55	2,1	4,5	3,5	7	15	30	4,8	105125	Δ	▲		▲		▲
L105.0510.3.5	1	1	0,55	2,1	4,5	3,5	7	20	35	4,8	105125		Δ				▲
L105.0510.4.5	1	1	0,55	2,1	4,5	3,5	7	25	40	4,8	105125		Δ				▲
L105.0510.2.6	1	1	0,55	3,3	5,7	3,7	7	15	30	6	105125		▲		▲		▲
L105.0612.2.6	1,25	1,25	0,65	3,3	5,7	3,7	7	15	30	6	105125	Δ	▲		▲		▲
L105.0612.3.6	1,25	1,25	0,65	3,3	5,7	3,7	7	20	35	6	105125		Δ				▲
L105.0612.4.6	1,25	1,25	0,65	3,3	5,7	3,7	7	25	40	6	105125		Δ				▲
L105.0815.2.7	1,5	1,5	0,75	4	6,4	3,7	7	15	30	7	105125		▲		▲		▲
L105.0815.3.7	1,5	1,5	0,75	4	6,4	3,7	7	20	35	7	105125		Δ				▲
L105.0815.4.7	1,5	1,5	0,75	4	6,4	3,7	7	25	40	7	105125		Δ				▲
P	O	•	•	•	•	•	•	•	•	•	•	•	•	•	•	•	•
M	-	•	•	•	•	•	•	•	•	•	•	•	•	•	•	•	•
K	-	O	•	•	•	•	•	•	•	•	•	•	•	•	•	•	•
N	-	-	•	•	•	•	•	•	•	•	•	•	•	•	•	•	•
S	-	-	•	•	•	•	•	•	•	•	•	•	•	•	•	•	•
H	-	-	-	-	-	-	-	-	-	-	-	-	-	-	-	-	-

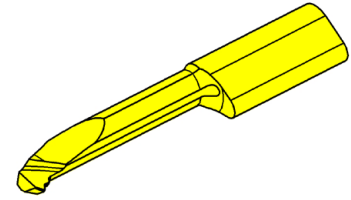
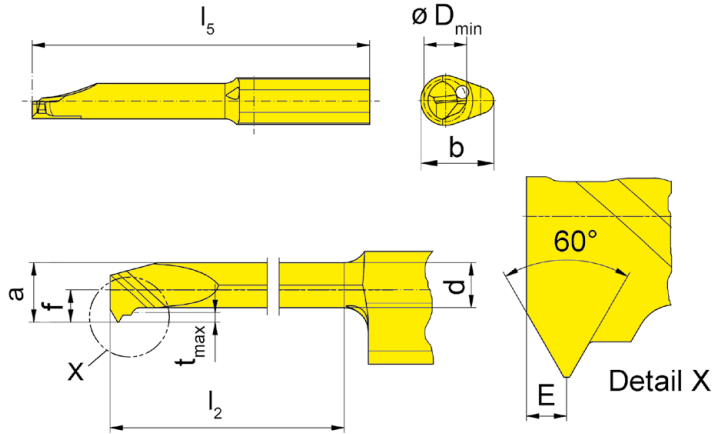
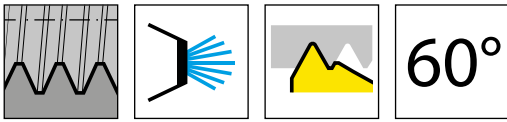

R = rechts wie gezeichnet
R = right hand version shown

L = links spiegelbildlich
L = left hand version

▲ ab Lager
on stock

HM-Sorten
Carbide grades
Δ 4 Wochen
4 weeks

Bestellnummer Part number	P	E	f	a	d	b	l ₂	l ₅	D _{min}	HIS	EG35	TH35
R105.VPM3.2.3	0,5	0,3	1,4	2,2	1,65	5,9	9	25	2,4	105123	▲	▲
R105.VPM3.4.3	0,5	0,3	1,4	2,2	1,65	5,9	16	35	2,4	105123	▲	▲
R105.VPM4.2.4	0,7	0,4	1,5	2,9	2,1	6,4	15	30	3,2	105124	▲	▲
R105.VPM4.3.4	0,7	0,4	1,5	2,9	2,1	6,4	20	35	3,2	105124	▲	▲
R105.VPM5.2.5	0,8	0,5	2	3,7	2,8	7	15	30	4,1	105125	▲	▲
R105.VPM5.4.5	0,8	0,5	2	3,7	2,8	7	25	40	4,1	105125	▲	▲
R105.VPM6.3.6	1	0,5	2,4	4,5	3,4	7	20	35	4,9	105125	▲	▲
R105.VPM6.4.6	1	0,5	2,4	4,5	3,4	7	25	40	4,9	105125	▲	▲
R105.VPM6.5.6	1	0,5	2,4	4,5	3,4	7	30	45	4,9	105125	▲	▲
R105.VPM8.3.8	1,25	0,7	3,8	6,2	4,7	7	20	35	6,6	105125	▲	▲
R105.VPM8.5.8	1,25	0,7	3,8	6,2	4,7	7	30	45	6,6	105125	▲	▲
L105.VPM3.2.3	0,5	0,3	1,4	2,2	1,65	5,9	9	25	2,4	105123	Δ	▲
L105.VPM3.4.3	0,5	0,3	1,4	2,2	1,65	5,9	16	35	2,4	105123	Δ	Δ
L105.VPM4.2.4	0,7	0,4	1,5	2,9	2,1	6,4	15	30	3,2	105124	Δ	Δ
L105.VPM4.3.4	0,7	0,4	1,5	2,9	2,1	6,4	20	35	3,2	105124	Δ	Δ
L105.VPM5.2.5	0,8	0,5	2	3,7	2,8	7	15	30	4,1	105125	Δ	▲
L105.VPM5.4.5	0,8	0,5	2	3,7	2,8	7	25	40	4,1	105125	Δ	▲
L105.VPM6.3.6	1	0,5	2,4	4,5	3,4	7	20	35	4,9	105125	▲	▲
L105.VPM6.4.6	1	0,5	2,4	4,5	3,4	7	25	40	4,9	105125	Δ	Δ
L105.VPM6.5.6	1	0,5	2,4	4,5	3,4	7	30	45	4,9	105125	Δ	▲
L105.VPM8.3.8	1,25	0,7	3,8	6,2	4,7	7	20	35	6,6	105125	Δ	▲
L105.VPM8.5.8	1,25	0,7	3,8	6,2	4,7	7	30	45	6,6	105125	Δ	▲

P	●	●
M	●	●
K	○	●
N	-	●
S	-	●
H	-	-

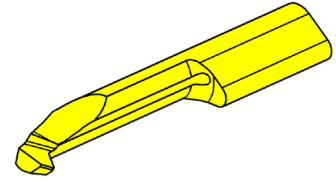
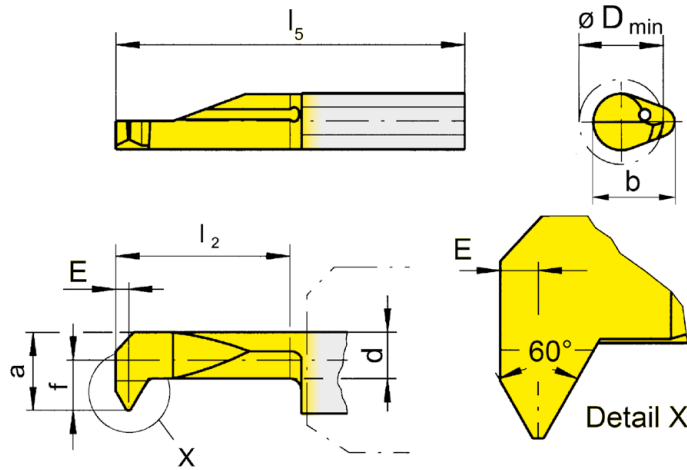
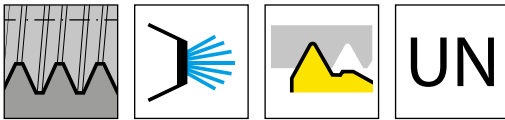

R = rechts wie gezeichnet
R = right hand version shown

L = links spiegelbildlich
L = left hand version

▲ ab Lager
on stock

HM-Sorten
Carbide grades
Δ 4 Wochen
4 weeks

Bestellnummer Part number	TPI _{min}	TPI _{max}	E	f	a	d	b	l ₂	l ₅	D _{min}	HIS	HM-Sorten							
												MG12	EG35	TF45	TH35	TI25	TN35		
R105.3240.2.4	32	40	0,45	1,9	3,7	2,7	6,4	15	30	4	105124		▲			Δ	▲		
R105.1620.2.5	16	20	0,7	2,3	4,7	3,3	7	15	30	5	105125		▲			▲			
R105.1620.3.5	16	20	0,7	2,3	4,7	3,3	7	20	35	5	105125		Δ			▲			
R105.2428.2.5	24	28	0,55	2,3	4,7	3,5	7	15	30	5	105125		▲		Δ	Δ	▲		
R105.3240.2.5	32	40	0,45	2,3	4,7	3,5	7	15	30	5	105125		▲	Δ		Δ	▲		
R105.1620.2.6	16	20	0,7	3,3	5,7	3,7	7	15	30	6	105125		▲	Δ	Δ	Δ	▲		
R105.1620.3.6	16	20	0,7	3,3	5,7	3,7	7	20	35	6	105125		▲				▲		
R105.1620.4.6	16	20	0,7	3,3	5,7	3,7	7	25	40	6	105125		▲				▲		
R105.2428.2.6	24	28	0,55	3,3	5,7	3,7	7	15	30	6	105125		Δ	▲		Δ	▲		
R105.2428.3.6	24	28	0,55	3,3	5,7	3,7	7	20	35	6	105125		▲				▲		
R105.2428.4.6	24	28	0,55	3,3	5,7	3,7	7	25	40	6	105125		▲				▲		
L105.3240.2.4	32	40	0,45	1,9	3,7	2,7	6,4	15	30	4	105124		Δ				▲		
L105.1620.2.5	16	20	0,7	2,3	4,7	3,3	7	15	30	5	105125		Δ			▲			
L105.1620.3.5	16	20	0,7	2,3	4,7	3,3	7	20	35	5	105125		Δ		Δ				
L105.2428.2.5	24	28	0,55	2,3	4,7	3,5	7	15	30	5	105125		Δ				▲		
L105.3240.2.5	32	40	0,45	2,3	4,7	3,5	7	15	30	5	105125		Δ				▲		
L105.1620.2.6	16	20	0,7	3,3	5,7	3,7	7	15	30	6	105125		Δ				▲		
L105.1620.3.6	16	20	0,7	3,3	5,7	3,7	7	20	35	6	105125		Δ				Δ		
L105.1620.4.6	16	20	0,7	3,3	5,7	3,7	7	25	40	6	105125		Δ				Δ		
L105.2428.2.6	24	28	0,55	3,3	5,7	3,7	7	15	30	6	105125		▲				▲		
L105.2428.3.6	24	28	0,55	3,3	5,7	3,7	7	20	35	6	105125		Δ				Δ		
L105.2428.4.6	24	28	0,55	3,3	5,7	3,7	7	25	40	6	105125		Δ				▲		
													P	o	•	•	•	•	•
													M	-	•	•	•	•	•
													K	-	o	•	•	•	•
													N	-	-	•	•	•	•
													S	-	-	•	•	•	•
													H	-	-	-	-	-	-

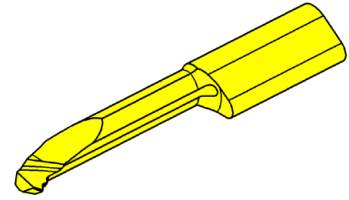
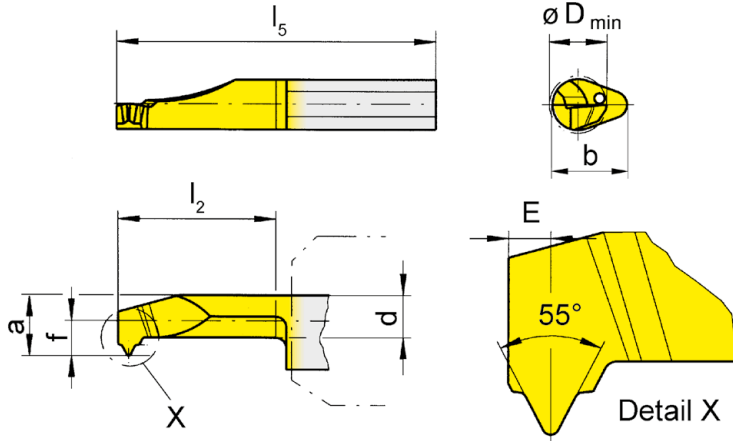
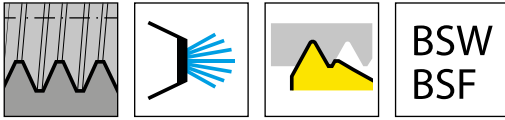

R = rechts wie gezeichnet
R = right hand version shown

L = links spiegelbildlich
L = left hand version

▲ ab Lager
on stock

HM-Sorten
Carbide grades
Δ 4 Wochen
4 weeks

Bestellnummer Part number	TPI	E	f	a	d	b	l ₂	l ₅	D _{min}	HIS	EG35	TN35
R105.5520.2.4	20	1	1,9	3,7	2,5	6,4	15	30	4	105124	▲	▲
R105.5524.2.5	24	0,8	2,3	4,7	3,5	7	15	30	5	105125	Δ	Δ
R105.5526.2.5	26	0,8	2,3	4,7	3,5	7	15	30	5	105125		▲
R105.5528.2.5	28	0,8	2,3	4,7	3,5	7	15	30	5	105125	▲	▲
L105.5524.2.5	24	0,8	2,3	4,7	3,5	7	15	30	5	105125	Δ	Δ
L105.5526.2.5	26	0,8	2,3	4,7	3,5	7	15	30	5	105125	Δ	Δ
L105.5528.2.5	28	0,8	2,3	4,7	3,5	7	15	30	5	105125	Δ	Δ
											P	●
											M	●
											K	●
											N	-
											S	-
											H	-

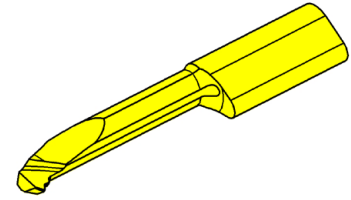
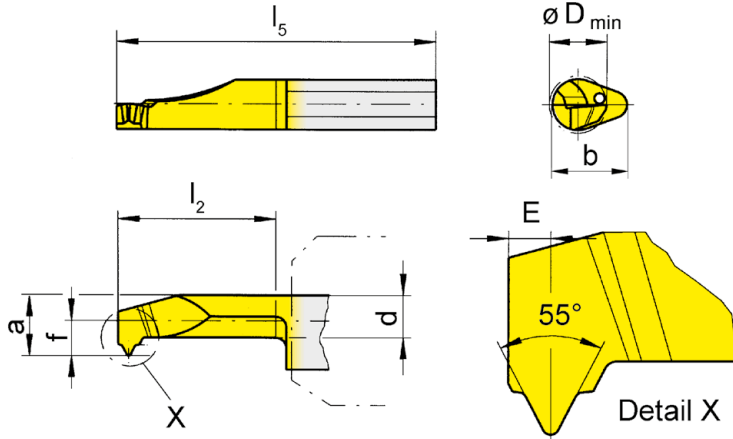
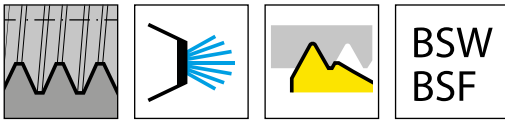

R = rechts wie gezeichnet
R = right hand version shown

L = links spiegelbildlich
L = left hand version

▲ ab Lager
on stock

HM-Sorten
Carbide grades
Δ 4 Wochen
4 weeks

Bestellnummer Part number	TPI	E	f	a	d	b	l ₂	l ₅	D _{min}	HIS	EG35	TH35	TN35
R105.5524.2.6	24	0,8	3,3	5,7	3,7	7	15	30	6	105125	Δ		Δ
R105.5526.2.6	26	0,8	3,3	5,7	3,7	7	15	30	6	105125	Δ		▲
R105.5528.2.6	28	0,8	3,3	5,7	3,7	7	15	30	6	105125	▲		▲
R105.5519.2.6	19	1	3,3	5,7	3,7	7	15	30	6	105125	▲	Δ	▲
R105.5520.2.6	20	1	3,3	5,7	3,7	7	15	30	6	105125	Δ		▲
R105.5522.2.6	22	1	3,3	5,7	3,7	7	15	30	6	105125	Δ		Δ
R105.5524.3.6	24	0,8	3,3	5,7	3,7	7	20	35	6	105125	▲		Δ
R105.5526.3.6	26	0,8	3,3	5,7	3,7	7	20	35	6	105125	Δ		Δ
R105.5528.3.6	28	0,8	3,3	5,7	3,7	7	20	35	6	105125	▲		▲
R105.5519.3.6	19	1	3,3	5,7	3,7	7	20	35	6	105125	▲		▲
R105.5522.3.6	22	1	3,3	5,7	3,7	7	20	35	6	105125	Δ		Δ
L105.5524.2.6	24	0,8	3,3	5,7	3,7	7	15	30	6	105125	Δ		Δ
L105.5526.2.6	26	0,8	3,3	5,7	3,7	7	15	30	6	105125	Δ		Δ
L105.5528.2.6	28	0,8	3,3	5,7	3,7	7	15	30	6	105125	Δ		Δ
L105.5519.2.6	19	1	3,3	5,7	3,7	7	15	30	6	105125	Δ		▲
L105.5520.2.6	20	1	3,3	5,7	3,7	7	15	30	6	105125	Δ		Δ
L105.5522.2.6	22	1	3,3	5,7	3,7	7	15	30	6	105125	Δ		Δ
L105.5528.3.6	28	0,8	3,3	5,7	3,7	7	20	35	6	105125	Δ		Δ
P	●	●	●										
M	●	●	●										
K	○	●	●										
N	-	●	●										
S	-	●	●										
H	-	-	-										

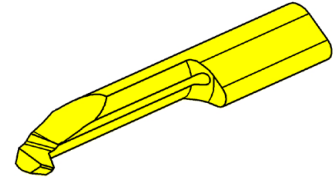
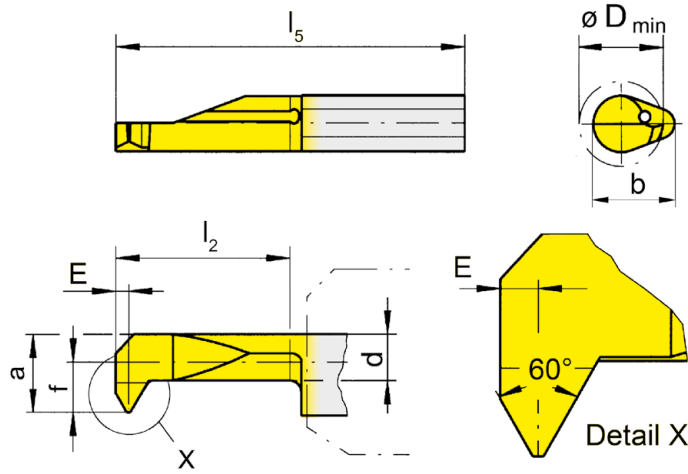
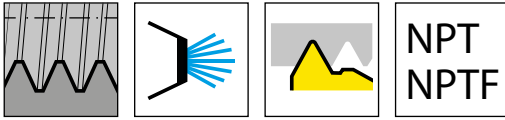

R = rechts wie gezeichnet
R = right hand version shown

L = links spiegelbildlich
L = left hand version

▲ ab Lager
on stock

HM-Sorten
Carbide grades
Δ 4 Wochen
4 weeks

Bestellnummer Part number	TPI	E	f	a	d	b	l ₂	l ₅	D _{min}	HIS	MG12	EG35	TH35	TI25	TN35
R105.NP18.2.6	18	1	3,3	5,7	3,7	7	15	30	6	105125	Δ	▲		Δ	▲
R105.NP18.3.6	18	1	3,3	5,7	3,7	7	20	35	6	105125		Δ	▲		▲
R105.NP18.4.6	18	1	3,3	5,7	3,7	7	25	40	6	105125		Δ	Δ		▲
R105.NP27.2.6	27	0,8	3,3	5,7	3,7	7	15	30	6	105125		▲		▲	▲
R105.NP27.3.6	27	0,8	3,3	5,7	3,7	7	20	35	6	105125		Δ	Δ	Δ	Δ
R105.NP27.4.6	27	0,8	3,3	5,7	3,7	7	25	40	6	105125		Δ	Δ		Δ
L105.NP18.2.6	18	1	3,3	5,7	3,7	7	15	30	6	105125		Δ		Δ	▲
L105.NP18.3.6	18	1	3,3	5,7	3,7	7	20	35	6	105125		Δ	Δ		Δ
L105.NP18.4.6	18	1	3,3	5,7	3,7	7	25	40	6	105125		Δ	Δ		Δ
L105.NP27.2.6	27	0,8	3,3	5,7	3,7	7	15	30	6	105125		Δ		Δ	▲
L105.NP27.3.6	27	0,8	3,3	5,7	3,7	7	20	35	6	105125		Δ	Δ	Δ	
L105.NP27.4.6	27	0,8	3,3	5,7	3,7	7	25	40	6	105125		Δ	Δ		Δ
P	o	•	•	•	•	•									
M	-	•	•	•	•	•									
K	-	o	•	•	•	•									
N	-	-	•	•	•	•									
S	-	-	•	•	•	•									
H	-	-	-	-	-	-									

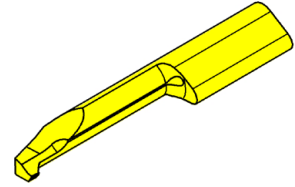
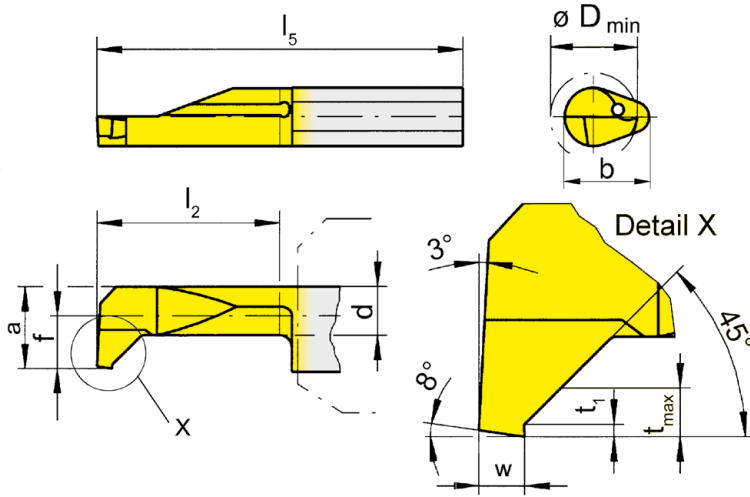
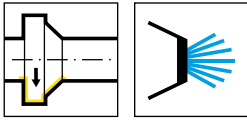

R = rechts wie gezeichnet
R = right hand version shown

L = links spiegelbildlich
L = left hand version

▲ ab Lager
on stock

HM-Sorten
Carbide grades
Δ 4 Wochen
4 weeks

Bestellnummer Part number	w	f	a	d	b	l ₂	l ₅	t _{max}	t ₁	D _{min}	HIS	MG12	EG35	TI25	TN35
R105.0810.1.3	0,7	1,4	2,7	2	5,9	10	25	0,5	0,2	3	105123		▲		▲
R105.0810.2.3	0,7	1,4	2,7	2	5,9	15	30	0,5	0,2	3	105123		Δ		▲
R105.0810.1.4	1	1,9	3,7	2,7	6,4	10	25	0,7	0,2	4	105124		▲		▲
R105.0810.2.4	1	1,9	3,7	2,7	6,4	15	30	0,7	0,2	4	105124		▲		▲
R105.0810.3.4	1	1,9	3,7	2,7	6,4	20	35	0,7	0,2	4	105124		Δ		▲
R105.0810.2.5	1	2,3	4,7	3,5	7	15	30	0,7	0,2	5	105125	▲	▲		▲
R105.0810.3.5	1	2,3	4,7	3,5	7	20	35	0,7	0,2	5	105125		▲	▲	▲
R105.0810.4.5	1	2,3	4,7	3,5	7	25	40	0,7	0,2	5	105125		▲	▲	▲
R105.0810.5.5	1	2,3	4,7	3,5	7	30	45	0,7	0,2	5	105125		▲	▲	▲
R105.0810.5.6	1	3,1	5,5	4,2	7	30	45	1	0,2	6	105125		▲		▲
R105.0810.7.6	1	3,1	5,5	4,2	7	40	55	1	0,2	6	105125		Δ		▲
L105.0810.1.3	0,7	1,4	2,7	2	5,9	10	25	0,5	0,2	3	105123		Δ		▲
L105.0810.2.3	0,7	1,4	2,7	2	5,9	15	30	0,5	0,2	3	105123		Δ		▲
L105.0810.1.4	1	1,9	3,7	2,7	6,4	10	25	0,7	0,2	4	105124		Δ		Δ
L105.0810.2.4	1	1,9	3,7	2,7	6,4	15	30	0,7	0,2	4	105124		Δ		▲
L105.0810.3.4	1	1,9	3,7	2,7	6,4	20	35	0,7	0,2	4	105124		Δ		▲
L105.0810.2.5	1	2,3	4,7	3,5	7	15	30	0,7	0,2	5	105125	▲	▲		▲
L105.0810.3.5	1	2,3	4,7	3,5	7	20	35	0,7	0,2	5	105125		Δ	▲	▲
L105.0810.4.5	1	2,3	4,7	3,5	7	25	40	0,7	0,2	5	105125		Δ	▲	▲
L105.0810.5.5	1	2,3	4,7	3,5	7	30	45	0,7	0,2	5	105125		Δ	▲	Δ
L105.0810.5.6	1	3,1	5,5	4,2	7	30	45	1	0,2	6	105125		Δ		▲
L105.0810.7.6	1	3,1	5,5	4,2	7	40	55	1	0,2	6	105125		Δ		Δ
P	o	•	•	•											
M	-	•	•	•											
K	-	o	•	•											
N	-	-	•	•											
S	-	-	•	•											
H	-	-	-	-											

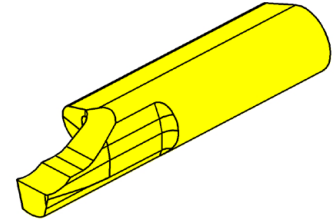
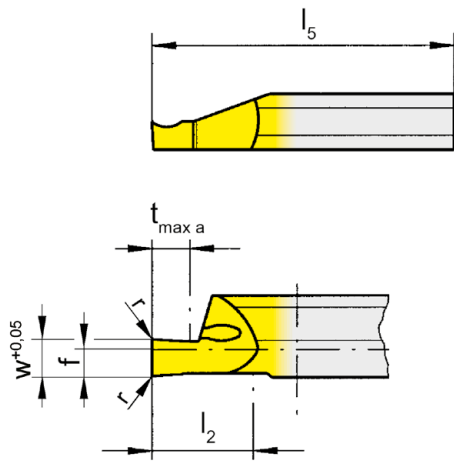
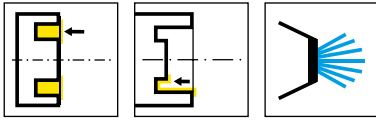

R = rechts wie gezeichnet
R = right hand version shown

L = links spiegelbildlich
L = left hand version

▲ ab Lager
on stock

HM-Sorten
Carbide grades
Δ 4 Wochen
4 weeks

Bestellnummer Part number	w	r	f	b	l ₂	l ₅	t _{max a}	D _{a min}	HIS	MG12	EG35	ES 15	TI25
R105.0505.1.8	0,5	-	2	7	10	25	2	5	105125	▲	▲	▲	▲
R105.0510.1.8	1	0,05	2	7	10	25	2	5	105125	▲	▲	▲	▲
R105.0515.1.8	1,5	0,05	2	7	10	25	3	5	105125	▲	▲	▲	▲
R105.0520.1.8	2	0,05	2	7	10	25	5	5	105125	▲	▲	▲	▲
R105.0510.2.8	1	0,05	2	7	15	35	2	5	105125	Δ	▲	▲	▲
R105.0515.2.8	1,5	0,05	2	7	15	35	3	5	105125	Δ	▲	▲	▲
R105.0520.2.8	2	0,05	2	7	15	35	5	5	105125	Δ	▲	▲	▲
L105.0510.1.8	1	0,05	2	7	10	25	2	5	105125	▲	▲	▲	▲
L105.0515.1.8	1,5	0,05	2	7	10	25	3	5	105125	▲	▲	▲	▲
L105.0520.1.8	2	0,05	2	7	10	25	5	5	105125	Δ	▲	▲	▲
L105.0510.2.8	1	0,05	2	7	15	35	2	5	105125	Δ	Δ	▲	▲
L105.0515.2.8	1,5	0,05	2	7	15	35	3	5	105125	Δ	▲	▲	▲
L105.0520.2.8	2	0,05	2	7	15	35	5	5	105125	Δ	▲	▲	▲
P	o	•	•	•	•	•	•	•					
M	-	•	•	•	•	•	•	•					
K	-	o	o	•	•	•	•	•					
N	-	-	-	•	•	•	•	•					
S	-	-	-	•	•	•	•	•					
H	-	-	-	-	-	-	-	-					

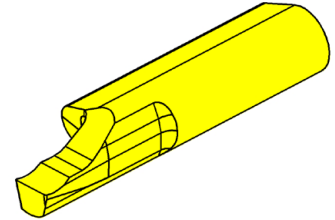
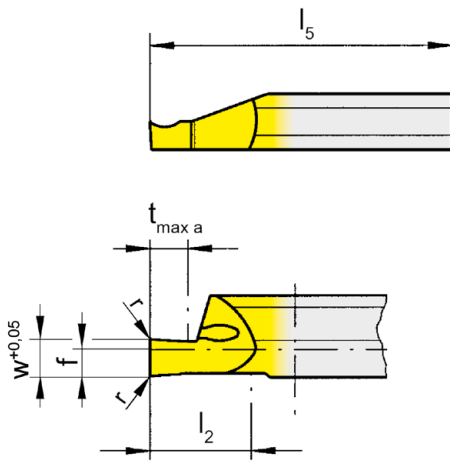
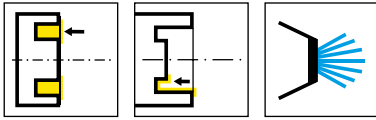

R = rechts wie gezeichnet
R = right hand version shown

L = links spiegelbildlich
L = left hand version

▲ ab Lager
on stock

HM-Sorten
Carbide grades
Δ 4 Wochen
4 weeks

Bestellnummer Part number	w	r	f	b	l ₂	l ₅	t _{max a}	D _{a min}	HIS	MG12	EG35	TI25
R105.0610.1.8	1	0,05	2	7	10	25	2	6	105125	▲	▲	▲
R105.0615.1.8	1,5	0,05	2	7	10	25	3	6	105125	▲	▲	▲
R105.0620.1.8	2	0,05	2	7	10	25	5	6	105125	▲	▲	▲
R105.0610.2.8	1	0,05	2	7	15	35	2	6	105125	▲	▲	▲
R105.0615.2.8	1,5	0,05	2	7	15	35	3	6	105125	▲	▲	▲
R105.0620.2.8	2	0,05	2	7	15	35	5	6	105125	▲	▲	▲
L105.0610.1.8	1	0,05	2	7	10	25	2	6	105125	Δ	▲	▲
L105.0615.1.8	1,5	0,05	2	7	10	25	3	6	105125	Δ	▲	▲
L105.0620.1.8	2	0,05	2	7	10	25	5	6	105125	Δ	▲	▲
L105.0610.2.8	1	0,05	2	7	15	35	2	6	105125	Δ	Δ	▲
L105.0615.2.8	1,5	0,05	2	7	15	35	3	6	105125	Δ	Δ	▲
L105.0620.2.8	2	0,05	2	7	15	35	5	6	105125	Δ	Δ	▲
P	o	•	•									
M	-	•	•									
K	-	o	•									
N	-	-	•									
S	-	-	•									
H	-	-	-									

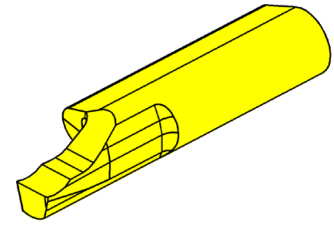
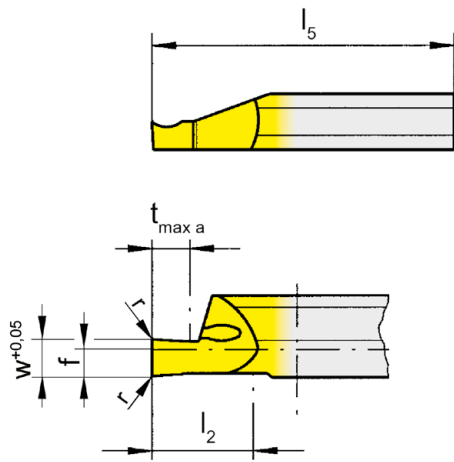
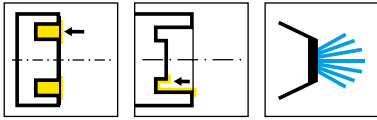

R = rechts wie gezeichnet
R = right hand version shown

L = links spiegelbildlich
L = left hand version

▲ ab Lager
on stock

HM-Sorten
Carbide grades
Δ 4 Wochen
4 weeks

Bestellnummer Part number	w	r	f	b	l ₂	l ₅	t _{max a}	D _{a min}	HIS	EG35	TI25	
R105.0810.1.8	1	0,15	2	7	10	25	2	8	105125	▲	▲	
R105.0815.1.8	1,5	0,15	2	7	10	25	3	8	105125	▲	▲	
R105.0820.1.8	2	0,15	2	7	10	25	4	8	105125	▲	▲	
R105.0825.1.8	2,5	0,15	2	7	10	25	5	8	105125	▲	▲	
R105.0830.1.8	3	0,15	2	7	10	25	6	8	105125	▲	▲	
R105.0810.2.8	1	0,15	2	7	15	35	2	8	105125	▲	▲	
R105.0815.2.8	1,5	0,15	2	7	15	35	3	8	105125	▲	▲	
R105.0820.2.8	2	0,15	2	7	15	35	4	8	105125	▲	▲	
R105.0825.2.8	2,5	0,15	2	7	15	35	5	8	105125	▲	▲	
R105.0830.2.8	3	0,15	2	7	15	35	6	8	105125	▲	▲	
L105.0810.1.8	1	0,15	2	7	10	25	2	8	105125	▲	▲	
L105.0815.1.8	1,5	0,15	2	7	10	25	3	8	105125	▲	▲	
L105.0820.1.8	2	0,15	2	7	10	25	4	8	105125	▲	▲	
L105.0825.1.8	2,5	0,15	2	7	10	25	5	8	105125	▲	▲	
L105.0830.1.8	3	0,15	2	7	10	25	6	8	105125	▲	▲	
L105.0810.2.8	1	0,15	2	7	15	35	2	8	105125	▲	▲	
L105.0815.2.8	1,5	0,15	2	7	15	35	3	8	105125	▲	▲	
L105.0820.2.8	2	0,15	2	7	15	35	4	8	105125	▲	▲	
L105.0825.2.8	2,5	0,15	2	7	15	35	5	8	105125	▲	▲	
L105.0830.2.8	3	0,15	2	7	15	35	6	8	105125	▲	▲	
P	●	●										
M	●	●										
K	○	●										
N	-	●										
S	-	●										
H	-	-										

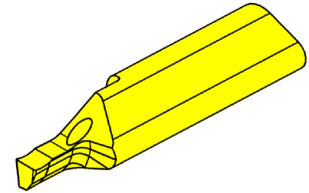
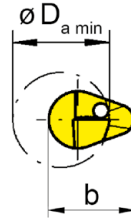
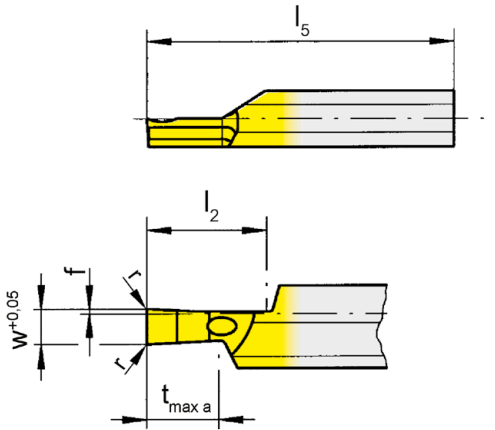
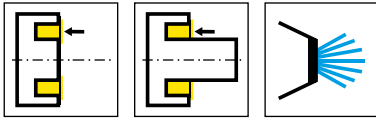

R = rechts wie gezeichnet
R = right hand version shown

L = links spiegelbildlich
L = left hand version

▲ ab Lager
on stock

HM-Sorten
Carbide grades
Δ 4 Wochen
4 weeks

Bestellnummer Part number	w	r	f	b	l ₂	l ₅	t _{max a}	D _{a min}	HIS	EG35	TI25
R105.0810.1.9	1	0,15	0,4	7	10	25	2	8	105125	▲	▲
R105.0815.1.9	1,5	0,15	0,4	7	10	25	3	8	105125	▲	▲
R105.0820.1.9	2	0,15	0,4	7	10	25	4	8	105125	▲	▲
R105.0825.1.9	2,5	0,15	0,4	7	10	25	5	8	105125	▲	▲
R105.0830.1.9	3	0,15	0,4	7	10	25	6	8	105125	▲	▲
L105.0810.1.9	1	0,15	0,4	7	10	25	2	8	105125	▲	▲
L105.0815.1.9	1,5	0,15	0,4	7	10	25	3	8	105125	▲	▲
L105.0820.1.9	2	0,15	0,4	7	10	25	4	8	105125	▲	▲
L105.0825.1.9	2,5	0,15	0,4	7	10	25	5	8	105125	▲	▲
L105.0830.1.9	3	0,15	0,4	7	10	25	6	8	105125	▲	▲
										P	●
										M	●
										K	●
										N	-
										S	-
										H	-

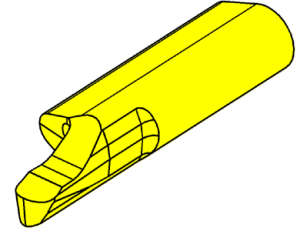
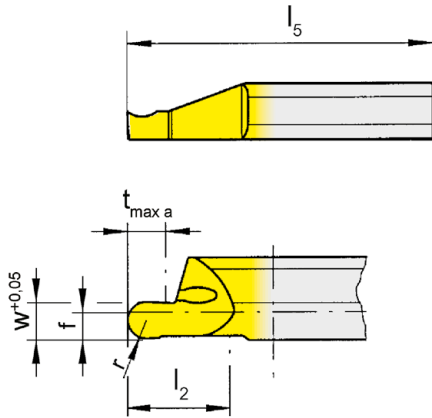
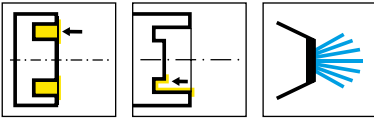

R = rechts wie gezeichnet
R = right hand version shown

L = links spiegelbildlich
L = left hand version

▲ ab Lager
on stock

HM-Sorten
Carbide grades
Δ 4 Wochen
4 weeks

Bestellnummer Part number	w	r	f	b	l_2	l_5	$t_{max a}$	$D_{a min}$	HIS	EG35	TI25	
R105.8V10.1.8	1	0,5	2	7	10	25	2	8	105125	▲	▲	●
R105.8V16.1.8	1,6	0,8	2	7	10	25	3	8	105125	▲	▲	●
R105.8V20.1.8	2	1	2	7	10	25	4	8	105125	▲	▲	●
R105.8V25.1.8	2,5	1,25	2	7	10	25	5	8	105125	▲	▲	●
R105.8V30.1.8	3	1,5	2	7	10	25	6	8	105125	▲	▲	●
R105.8V10.2.8	1	0,5	2	7	15	35	2	8	105125	▲	▲	●
R105.8V16.2.8	1,6	0,8	2	7	15	35	3	8	105125	▲	▲	●
R105.8V20.2.8	2	1	2	7	15	35	4	8	105125	▲	▲	●
R105.8V25.2.8	2,5	1,25	2	7	15	35	5	8	105125	▲	▲	●
R105.8V30.2.8	3	1,5	2	7	15	35	6	8	105125	▲	▲	●
L105.8V10.1.8	1	0,5	2	7	10	25	2	8	105125	▲	▲	●
L105.8V16.1.8	1,6	0,8	2	7	10	25	3	8	105125	▲	▲	●
L105.8V20.1.8	2	1	2	7	10	25	4	8	105125	▲	▲	●
L105.8V25.1.8	2,5	1,25	2	7	10	25	5	8	105125	Δ	▲	●
L105.8V30.1.8	3	1,5	2	7	10	25	6	8	105125	▲	▲	●
L105.8V10.2.8	1	0,5	2	7	15	35	2	8	105125	Δ	▲	●
L105.8V16.2.8	1,6	0,8	2	7	15	35	3	8	105125	Δ	▲	●
L105.8V20.2.8	2	1	2	7	15	35	4	8	105125	▲	▲	●
L105.8V25.2.8	2,5	1,25	2	7	15	35	5	8	105125	Δ	Δ	●
L105.8V30.2.8	3	1,5	2	7	15	35	6	8	105125	Δ	▲	●
P	●	●										●
M	●	●										●
K	○	●										●
N	-	●										●
S	-	●										●
H	-	-										●

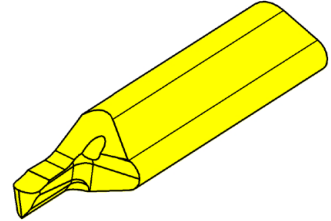
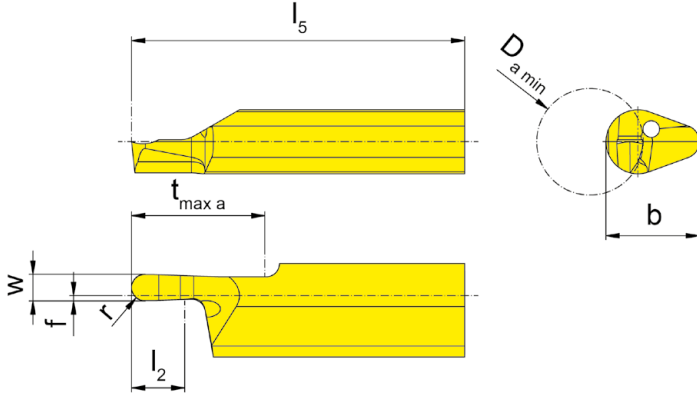
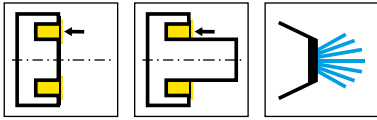

R = rechts wie gezeichnet
R = right hand version shown

L = links spiegelbildlich
L = left hand version

▲ ab Lager
on stock

HM-Sorten
Carbide grades
Δ 4 Wochen
4 weeks

Bestellnummer Part number	w	r	f	b	l_2	l_5	$t_{\max a}$	$D_{a \min}$	HIS	EG35
R105.8V10.1.9	1	0,5	0,4	7	10	25	2	8	105125	▲
R105.8V16.1.9	1,6	0,8	0,4	7	10	25	3	8	105125	▲
R105.8V20.1.9	2	1	0,4	7	10	25	4	8	105125	▲
R105.8V25.1.9	2,5	1,25	0,4	7	10	25	5	8	105125	▲
R105.8V30.1.9	3	1,5	1	7	10	25	6	8	105125	▲
L105.8V10.1.9	1	0,5	0,4	7	10	25	2	8	105125	▲
L105.8V16.1.9	1,6	0,8	0,4	7	10	25	3	8	105125	▲
L105.8V20.1.9	2	1	0,4	7	10	25	4	8	105125	▲
L105.8V25.1.9	2,5	1,25	0,4	7	10	25	5	8	105125	▲
L105.8V30.1.9	3	1,5	1	7	10	25	6	8	105125	▲
										P ●
										M ●
										K ○
										N -
										S -
										H -

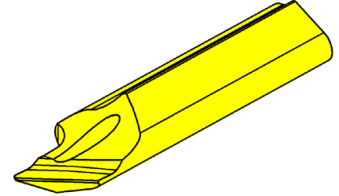
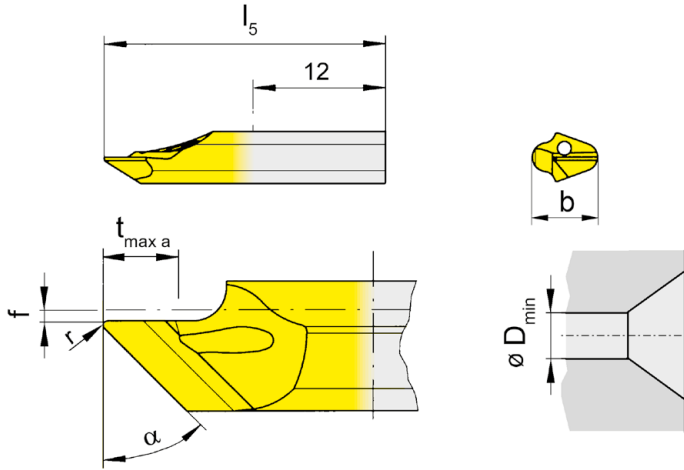
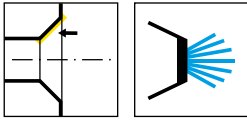

R = rechts wie gezeichnet
R = right hand version shown

L = links spiegelbildlich
L = left hand version

▲ ab Lager
on stock

HM-Sorten
Carbide grades
Δ 4 Wochen
4 weeks

Bestellnummer Part number	r	f	b	l_5	$t_{max a}$	D_{min}	α	HIS	EG35	TF45	TI25	TN35
R105.0045.0.1	0,2	0,5	5,9	20	3,5	1	45°	105123	▲	▲		▲
R105.0045.1.1	0,2	0,5	5,9	25	3,5	1	45°	105123	▲	▲	Δ	
R105.0060.0.1	0,2	0,5	5,9	20	4	1	60°	105123	▲	▲		
R105.0060.1.1	0,2	0,5	5,9	25	4	1	60°	105123	▲	▲	Δ	
L105.0045.0.1	0,2	0,5	5,9	20	3,5	1	45°	105123	▲	▲		▲
L105.0045.1.1	0,2	0,5	5,9	25	3,5	1	45°	105123	▲	▲	Δ	
L105.0060.0.1	0,2	0,5	5,9	20	4	1	60°	105123	▲	▲		
L105.0060.1.1	0,2	0,5	5,9	25	4	1	60°	105123	▲	▲	Δ	
P	●	●	●	●	●	●	●	●	●	●	●	●
M	●	●	●	●	●	●	●	●	●	●	●	●
K	○	●	●	●	●	●	●	●	●	●	●	●
N	-	●	●	●	●	●	●	●	●	●	●	●
S	-	●	●	●	●	●	●	●	●	●	●	●
H	-	-	-	-	-	-	-	-	-	-	-	-

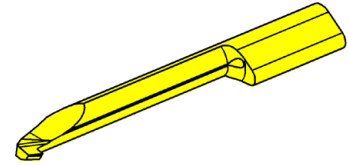
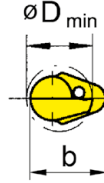
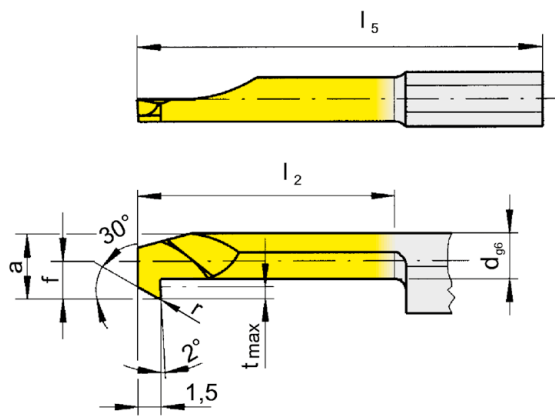
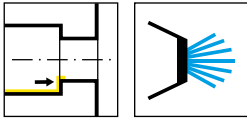

R = rechts wie gezeichnet
R = right hand version shown

L = links spiegelbildlich
L = left hand version

▲ ab Lager
on stock

HM-Sorten
Carbide grades
Δ 4 Wochen
4 weeks

Bestellnummer Part number	r	f	a	d	b	l ₂	l ₅	t _{max}	D _{min}	HIS	EG35	TH35	TI25
R105.3013.2.3	0,1	1,3	2,6	1,9	5,9	15	30	0,5	3	105123	▲	Δ	▲
R105.3013.3.3	0,1	1,3	2,6	1,9	5,9	20	35	0,5	3	105123	▲		▲
R105.3019.2.4	0,15	1,9	3,7	2,7	6,4	15	30	0,8	4	105124	▲		▲
R105.3019.4.4	0,15	1,9	3,7	2,7	6,4	25	40	0,8	4	105124	▲		▲
R105.3023.3.5	0,2	2,3	4,7	3,5	7	20	35	1	5	105125	▲		▲
R105.3023.5.5	0,2	2,3	4,7	3,5	7	30	45	1	5	105125	▲		▲
R105.3033.3.6	0,2	3,3	5,7	3,7	7	20	35	1,8	6	105125	▲		▲
R105.3033.5.6	0,2	3,3	5,7	3,7	7	30	45	1,8	6	105125	▲		▲
R105.3040.3.7	0,2	4	6,4	3,7	7	20	35	2,5	6,8	105125	▲		▲
R105.3040.5.7	0,2	4	6,4	3,7	7	30	45	2,5	6,8	105125	▲		▲
L105.3013.2.3	0,1	1,3	2,6	1,9	5,9	15	30	0,5	3	105123	Δ		▲
L105.3013.3.3	0,1	1,3	2,6	1,9	5,9	20	35	0,5	3	105123	Δ		Δ
L105.3019.2.4	0,15	1,9	3,7	2,7	6,4	15	30	0,8	4	105124			Δ
L105.3019.4.4	0,15	1,9	3,7	2,7	6,4	25	40	0,8	4	105124	Δ		Δ
L105.3023.3.5	0,2	2,3	4,7	3,5	7	20	35	1	5	105125	▲		▲
L105.3023.5.5	0,2	2,3	4,7	3,5	7	30	45	1	5	105125	Δ		Δ
L105.3033.3.6	0,2	3,3	5,7	3,7	7	20	35	1,8	6	105125	Δ		▲
L105.3033.5.6	0,2	3,3	5,7	3,7	7	30	45	1,8	6	105125	Δ		Δ
L105.3040.3.7	0,2	4	6,4	3,7	7	20	35	2,5	6,8	105125	▲		▲
L105.3040.5.7	0,2	4	6,4	3,7	7	30	45	2,5	6,8	105125	Δ		Δ
P	●	●	●										
M	●	●	●										
K	○	●	●										
N	-	●	●										
S	-	●	●										
H	-	-	-										

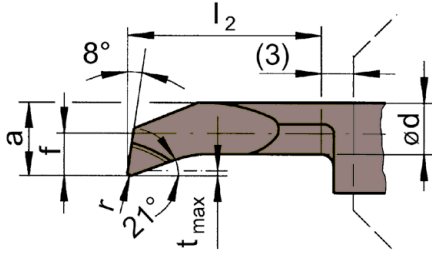
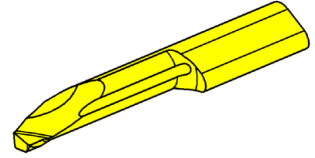
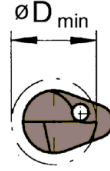
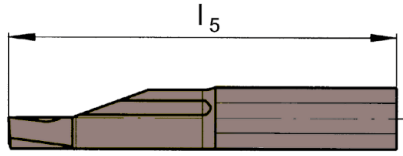
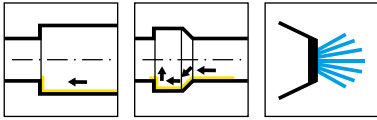

R = rechts wie gezeichnet
R = right hand version shown

L = links spiegelbildlich
L = left hand version

▲ ab Lager
on stock

HM-Sorten
Carbide grades
Δ 4 Wochen
4 weeks

Bestellnummer Part number	r	f	a	d	b	l_2	l_5	t_{max}	D_{min}	HIS	SG36
R105.1819.01.1.4F	0,1	1,9	3,7	2,9	6,4	10	25	0,3	4	105124	▲
R105.1819.01.2.4F	0,1	1,9	3,7	2,9	6,4	15	30	0,3	4	105124	▲
R105.1823.15.2.5F	0,15	2,3	4,7	4	7	15	30	0,5	5	105125	▲
L105.1819.01.1.4F	0,1	1,9	3,7	2,9	6,4	10	25	0,3	4	105124	▲
L105.1819.01.2.4F	0,1	1,9	3,7	2,9	6,4	15	30	0,3	4	105124	▲
L105.1823.15.2.5F	0,15	2,3	4,7	4	7	15	30	0,5	5	105125	▲
											P -
											M -
											K -
											N -
											S ●
											H ●



Abbildung = rechtsschneidend
Picture = right hand cutting version

Bestellnummer Part number	d	l_1	h	l_4	HWS
B105.0012.02	12	85	11	50	105225
B105.0016.02	16	85	14	50	105225
B105.0020.02	20	100	18	55	105225
B105.0022.02	22	100	20	55	105225

Ersatzteile
Spare Parts

Klemmhalter Toolholder	Spannschraube Clamping Screw	TORX PLUS®-Schlüssel TORX PLUS® Wrench
B105...	6.075T15P	T15PQ

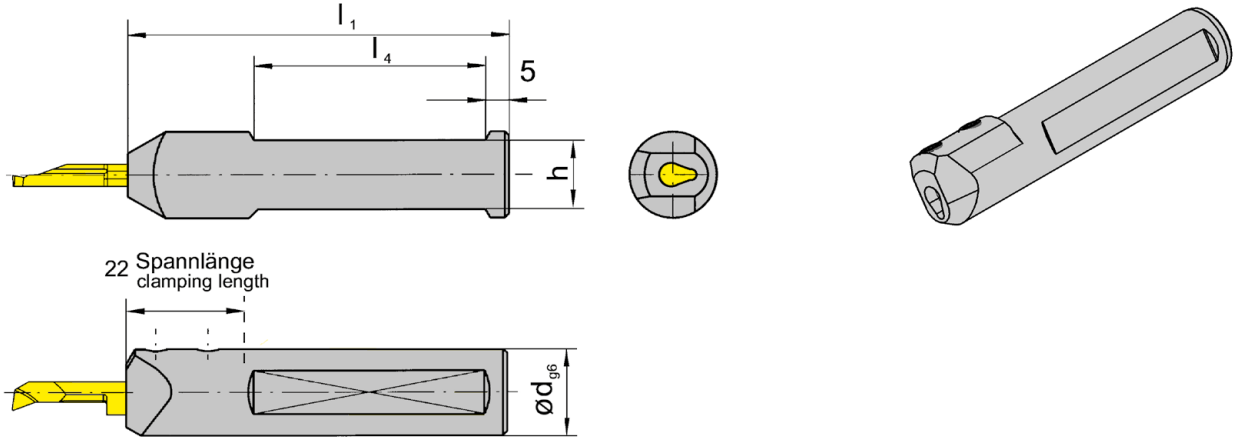
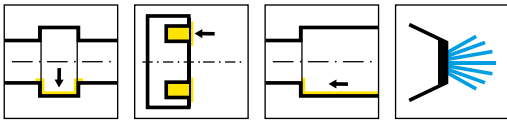
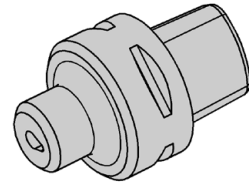
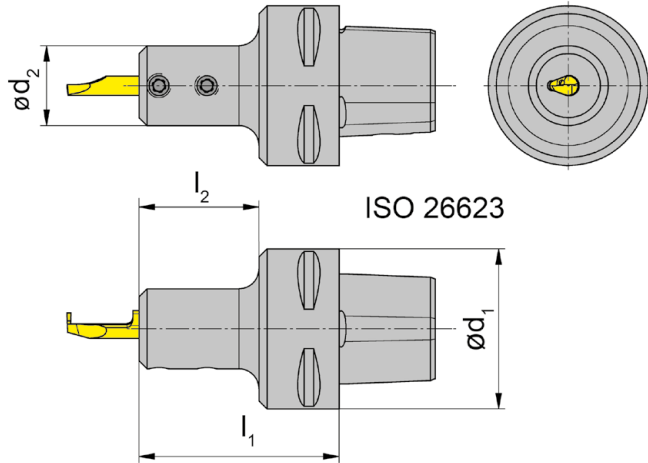
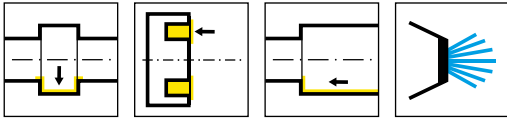

L = links wie gezeichnet
L = left hand version shown

R = rechts spiegelbildlich
R = right hand version

Bestellnummer Part number	d_1	d_2	l_1	l_2	HWS
RB105.00C4.20.1.02	40	20	50	20	105225
RB105.00C6.20.1.02	63	20	52	22	105225
LB105.00C4.20.1.02	40	20	50	20	105225
LB105.00C6.20.1.02	63	20	52	22	105225

nur für Schneidplatten mit verlängertem Spannschaft
only usable for inserts with extended clamping length

Ersatzteile

Spare Parts

Klemmhalter Toolholder	Spannschraube Clamping Screw	TORX PLUS®-Schlüssel TORX PLUS® Wrench
R/LB105...	6.075T15P	T15PQ

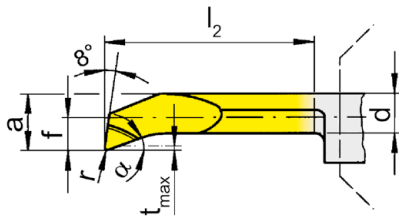
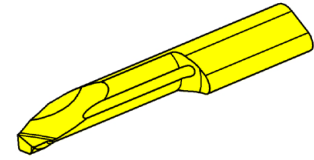
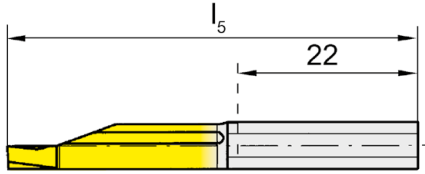
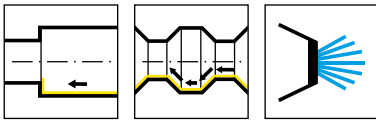

R = rechts wie gezeichnet
R = right hand version shown

L = links spiegelbildlich
L = left hand version

▲ ab Lager
on stock

HM-Sorten
Carbide grades
Δ 4 Wochen
4 weeks

Bestellnummer Part number	r	f	a	d	b	l ₂	l ₅	t _{max}	D _{min}	α	HIS	EG35	TH35	TI25	TN35	
R105.1823.4.5.2	0,1	2,3	4,7	4,2	7	25	50	0,3	5	21°	105225	Δ	▲	▲		
R105.1823.5.5.2	0,1	2,3	4,7	4,2	7	30	55	0,3	5	21°	105225	Δ	▲	▲		
R105.1833.4.6.2	0,1	3,3	5,7	4,9	7	25	50	0,3	6	21°	105225	Δ	▲	▲		
R105.1833.5.6.2	0,1	3,3	5,7	4,9	7	30	55	0,3	6	21°	105225	Δ	▲	▲		
R105.1840.4.7.2	0,1	4	6,4	5,4	7	25	50	0,3	6,8	21°	105225	Δ	▲	▲		
R105.1840.5.7.2	0,1	4	6,4	5,4	7	30	55	0,3	6,8	21°	105225	Δ	▲	▲	Δ	
R105.1840.7.7.2	0,1	4	6,4	5,4	7	40	65	0,3	6,8	21°	105225	▲		▲		
R105.4733.5.6.2	0,1	3,3	5,7	3,7	7	30	55	1,8	6	47°	105225	Δ	▲	▲		
L105.1823.4.5.2	0,1	2,3	4,7	4,2	7	25	50	0,3	5	21°	105225	Δ	▲	▲		
L105.1823.5.5.2	0,1	2,3	4,7	4,2	7	30	55	0,3	5	21°	105225		▲	Δ		
L105.1833.4.6.2	0,1	3,3	5,7	4,9	7	25	50	0,3	6	21°	105225	Δ	Δ	Δ		
L105.1833.5.6.2	0,1	3,3	5,7	4,9	7	30	55	0,3	6	21°	105225	Δ	▲	Δ		
L105.1840.4.7.2	0,1	4	6,4	5,4	7	25	50	0,3	6,8	21°	105225	Δ	▲	▲		
L105.1840.5.7.2	0,1	4	6,4	5,4	7	30	55	0,3	6,8	21°	105225	Δ	Δ	▲		
L105.1840.7.7.2	0,1	4	6,4	5,4	7	40	65	0,3	6,8	21°	105225	Δ		Δ		
L105.4733.5.6.2	0,1	3,3	5,7	3,7	7	30	55	1,8	6	47°	105225	Δ	Δ	Δ		
mit verlängertem Spannschaft with extended clamping length												P	●	●	●	●
												M	●	●	●	●
												K	○	●	●	●
												N	-	●	●	●
												S	-	●	●	●
												H	-	-	-	-

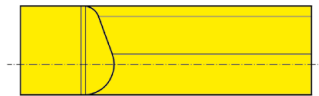
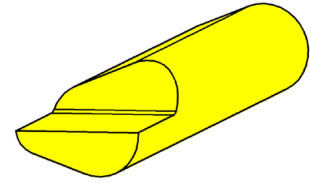
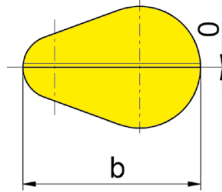
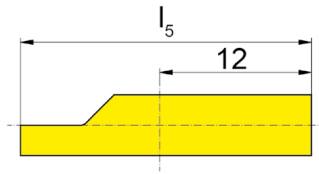
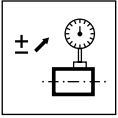

R = rechts wie gezeichnet
 R = right hand version shown

Bestellnummer Part number	l_5	b	HIS
R105.LEHR.H.03	25	5,9	105123
L105.LEHR.H.03	25	5,9	105123
R105.LEHR.H.04	25	6,4	105124
L105.LEHR.H.04	25	6,4	105124
R105.LEHR.H.05	25	7,0	105125
L105.LEHR.H.05	25	7,0	105125

Platte zum Einrichten des Werkzeugs
 Insert for tool set up

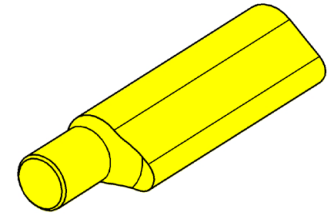
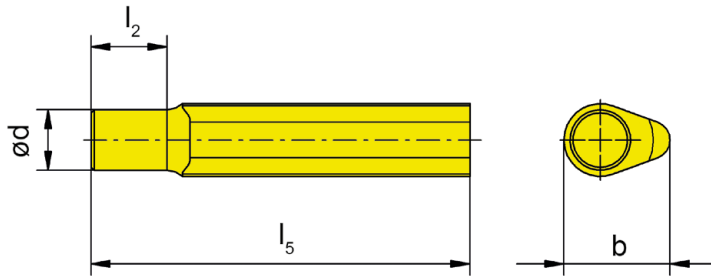
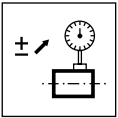

Bestellnummer Part number	d	b	l_2	l_5	HIS
105.LEHR.D.03	1,7	5,9	3	25	105123
105.LEHR.D.04	1,7	6,4	3	25	105124
105.LEHR.D.05	4	7	5	25	105125

Platte zum Einrichten des Werkzeugs
Insert for tool set up

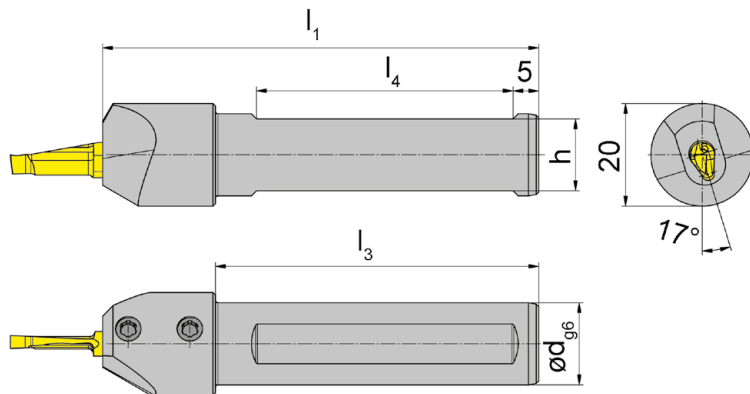
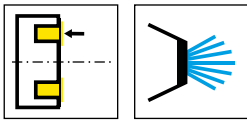

L = links wie gezeichnet
L = left hand version shown

R = rechts spiegelbildlich
R = right hand version

Bestellnummer Part number	d	l_1	l_3	h	l_4	HWS
RB105.0016.12.2	16	85	63	14	50	105225
RB105.0020.12.2	20	100	-	18	55	105225
LB105.0016.12.2	16	85	63	14	50	105225
LB105.0020.12.2	20	100	-	18	55	105225

Ersatzteile

Spare Parts

Klemmhalter Toolholder	Spannschraube Clamping Screw	TORX PLUS®-Schlüssel TORX PLUS® Wrench
R/LB105...	6.075T15P	T15PQ

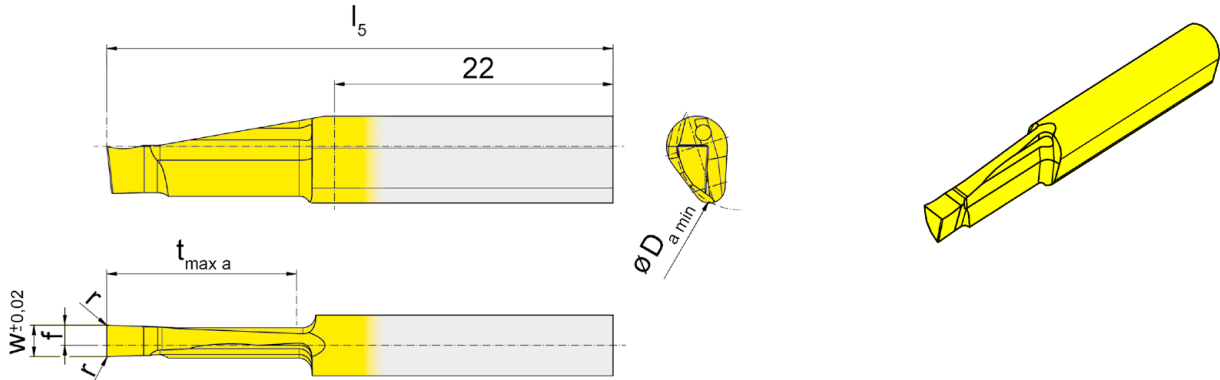
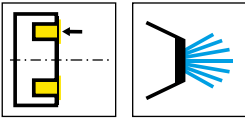

L = links wie gezeichnet
L = left hand version shown

R = rechts spiegelbildlich
R = right hand version

▲ ab Lager
on stock

HM-Sorten
Carbide grades
Δ 4 Wochen
4 weeks

Bestellnummer Part number	w	r	f	l_s	$t_{\text{max a}}$	$D_{a \text{ min}}$	HIS	EG35	TI25
RA105.1020.2.2	2	0,1	1,4	40	15	10	105225	▲	▲
RA105.1025.2.2	2,5	0,1	1,6	40	15	10	105225	▲	▲
RA105.1030.2.2	3	0,1	1	40	15	10	105225	▲	▲
LA105.1020.2.2	2	0,1	1,4	40	15	10	105225	▲	▲
LA105.1025.2.2	2,5	0,1	1,6	40	15	10	105225	▲	▲
LA105.1030.2.2	3	0,1	1	40	15	10	105225	▲	▲

Axialstechen ins Volle bei voller Stechtiefe nur bei $D_{a \text{ min}}$ 10 - 40 mm möglich!
Face grooving with full width of the full depth only possible between $D_{a \text{ min}}$ 10 - 40 mm!

P	●	●
M	●	●
K	○	●
N	-	●
S	-	●
H	-	-

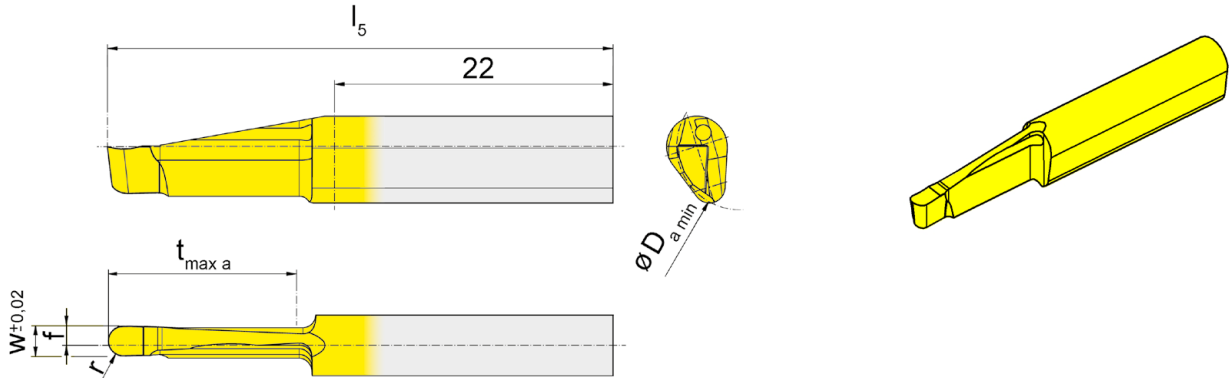
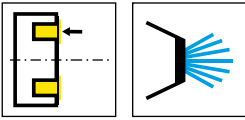

L = links wie gezeichnet
L = left hand version shown

R = rechts spiegelbildlich
R = right hand version

▲ ab Lager
on stock

HM-Sorten
Carbide grades
Δ 4 Wochen
4 weeks

Bestellnummer Part number	w	r	f	l_5	$t_{\max a}$	$D_{a \min}$	HIS	EG35	TI25
RA105.1020.10.2.2	2	1	1,4	40	15	10	105225	▲	▲
RA105.1025.12.2.2	2,5	1,25	1,6	40	15	10	105225	Δ	▲
RA105.1030.15.2.2	3	1,5	1,9	40	15	10	105225	▲	▲
LA105.1020.10.2.2	2	1	1,4	40	15	10	105225	Δ	▲
LA105.1025.12.2.2	2,5	1,25	1,6	40	15	10	105225	Δ	Δ
LA105.1030.15.2.2	3	1,5	1,9	40	15	10	105225	Δ	▲

Axialstechen ins Volle bei voller Stechtiefe nur bei $D_{a \min}$ 10 - 40 mm möglich!
Face grooving with full width of the full depth only possible between $D_{a \min}$ 10 - 40 mm!

P	●	●
M	●	●
K	○	●
N	-	●
S	-	●
H	-	-

Schneidplatte Insert

105

$\varnothing \geq 3 \text{ mm}$



A

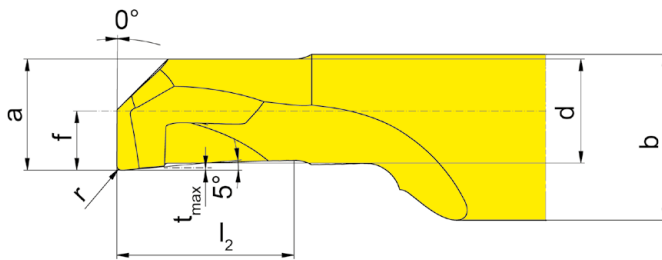
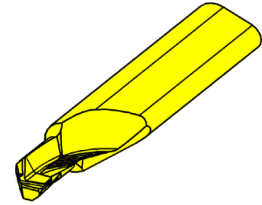
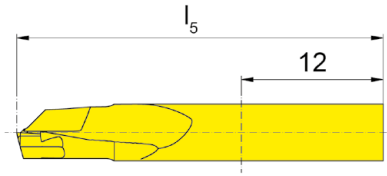
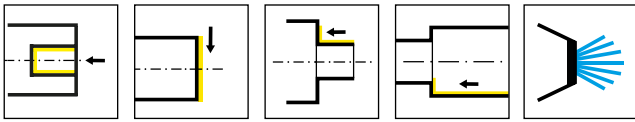

R = rechts wie gezeichnet
R = right hand version shown

L = links spiegelbildlich
L = left hand version

▲ ab Lager
on stock

HM-Sorten
Carbide grades
Δ 4 Wochen
4 weeks

Bestellnummer Part number	r	f	a	d	b	l_2	l_5	t_{max}	Ds	HIS	EG35
R105.BO.30.20.045.1	0,2	1,5	2,7	2,4	7	4,5	31	0,1	3	105125	▲
R105.BO.30.20.075.1	0,2	1,5	2,7	2,4	7	7,5	31	0,1	3	105125	▲
R105.BO.40.20.060.1	0,2	2	3,7	3,4	7	6	31	0,1	4	105125	▲
R105.BO.40.20.100.1	0,2	2	3,7	3,4	7	10	31	0,1	4	105125	▲
R105.BO.50.20.075.1	0,2	2,5	4,7	4,4	7	7,5	31	0,1	5	105125	▲
R105.BO.50.20.125.1	0,2	2,5	4,7	4,4	7	12,5	36	0,1	5	105125	▲
R105.BO.60.20.090.1	0,2	3	5,4	5,1	7	9	31	0,1	6	105125	▲
R105.BO.60.20.150.1	0,2	3	5,4	5,1	7	15	36	0,1	6	105125	▲
R105.BO.70.20.105.1	0,2	3,5	5,9	5,6	7	10,5	36	0,1	7	105125	▲
R105.BO.70.20.175.1	0,2	3,5	5,9	5,6	7	17,5	40	0,1	7	105125	▲
L105.BO.30.20.045.1	0,2	1,5	2,7	2,4	7	4,5	31	0,1	3	105125	Δ
L105.BO.30.20.075.1	0,2	1,5	2,7	2,4	7	7,5	31	0,1	3	105125	Δ
L105.BO.40.20.060.1	0,2	2	3,7	3,4	7	6	31	0,1	4	105125	Δ
L105.BO.40.20.100.1	0,2	2	3,7	3,4	7	10	31	0,1	4	105125	Δ
L105.BO.50.20.075.1	0,2	2,5	4,7	4,4	7	7,5	31	0,1	5	105125	Δ
L105.BO.50.20.125.1	0,2	2,5	4,7	4,4	7	12,5	36	0,1	5	105125	Δ
L105.BO.60.20.090.1	0,2	3	5,4	5,1	7	9	31	0,1	6	105125	Δ
L105.BO.60.20.150.1	0,2	3	5,4	5,1	7	15	36	0,1	6	105125	Δ
L105.BO.70.20.105.1	0,2	3,5	5,9	5,6	7	10,5	36	0,1	7	105125	Δ
L105.BO.70.20.175.1	0,2	3,5	5,9	5,6	7	17,5	40	0,1	7	105125	Δ

mit innerer Kühlmittelzufuhr ab Schneidkreisdurchmesser 5 mm
with through coolant supply from cutting diameter 5 mm

mit Spantreppe
with chip breaker

P	●
M	●
K	○
N	-
S	-
H	-

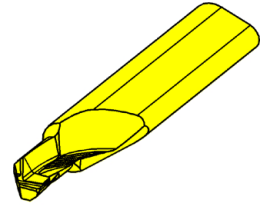
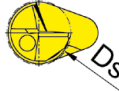
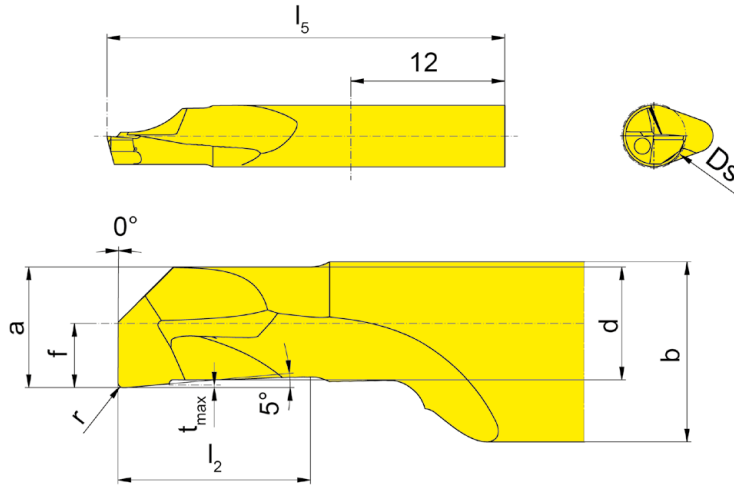
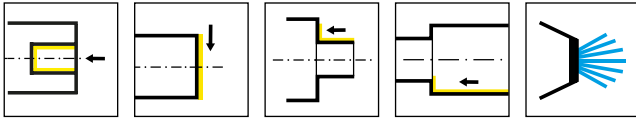

R = rechts wie gezeichnet
R = right hand version shown

L = links spiegelbildlich
L = left hand version

▲ ab Lager
on stock

HM-Sorten
Carbide grades
Δ 4 Wochen
4 weeks

Bestellnummer Part number	r	f	a	d	b	l ₂	l ₅	t _{max}	Ds	HIS	EG35
R105.BO.30.20.045.2	0,2	1,5	2,7	2,4	7	4,5	31	0,1	3	105125	▲
R105.BO.30.20.075.2	0,2	1,5	2,7	2,4	7	7,5	31	0,1	3	105125	▲
R105.BO.40.20.060.2	0,2	2	3,7	3,4	7	6	31	0,1	4	105125	▲
R105.BO.40.20.100.2	0,2	2	3,7	3,4	7	10	31	0,1	4	105125	▲
R105.BO.50.20.075.2	0,2	2,5	4,7	4,4	7	7,5	31	0,1	5	105125	▲
R105.BO.50.20.125.2	0,2	2,5	4,7	4,4	7	12,5	36	0,1	5	105125	▲
R105.BO.60.20.090.2	0,2	3	5,4	5,1	7	9	31	0,1	6	105125	▲
R105.BO.60.20.150.2	0,2	3	5,4	5,1	7	15	36	0,1	6	105125	▲
R105.BO.70.20.105.2	0,2	3,5	5,9	5,6	7	10,5	36	0,1	7	105125	▲
R105.BO.70.20.175.2	0,2	3,5	5,9	5,6	7	17,5	40	0,1	7	105125	▲
L105.BO.30.20.045.2	0,2	1,5	2,7	2,4	7	4,5	31	0,1	3	105125	Δ
L105.BO.30.20.075.2	0,2	1,5	2,7	2,4	7	7,5	31	0,1	3	105125	Δ
L105.BO.40.20.060.2	0,2	2	3,7	3,4	7	6	31	0,1	4	105125	Δ
L105.BO.40.20.100.2	0,2	2	3,7	3,4	7	10	31	0,1	4	105125	Δ
L105.BO.50.20.075.2	0,2	2,5	4,7	4,4	7	7,5	31	0,1	5	105125	Δ
L105.BO.50.20.125.2	0,2	2,5	4,7	4,4	7	12,5	36	0,1	5	105125	Δ
L105.BO.60.20.090.2	0,2	3	5,4	5,1	7	9	31	0,1	6	105125	Δ
L105.BO.60.20.150.2	0,2	3	5,4	5,1	7	15	36	0,1	6	105125	Δ
L105.BO.70.20.105.2	0,2	3,5	5,9	5,6	7	10,5	36	0,1	7	105125	Δ
L105.BO.70.20.175.2	0,2	3,5	5,9	5,6	7	17,5	40	0,1	7	105125	Δ

mit innerer Kühlmittelzufuhr ab Schneidkreisdurchmesser 5 mm
with through coolant supply from cutting diameter 5 mm

Universalgeometrie
universal geometry

P	●
M	●
K	○
N	-
S	-
H	-



Abbildung = rechtsschneidend
Picture = right hand cutting version

Bestellnummer Part number	d	l ₁	h	l ₄	l ₂	d ₂	HWS
B109.0012.01	12	75	10	50	16	20	109140
B109.0016.01	16	75	14	50	16	20	109140
B109.0020.01	20	90	18	55	-	20	109140
B109.0025.01	25	100	23	55	-	25	109140

Ersatzteile
Spare Parts

Klemmhalter Toolholder	Spannschraube Clamping Screw	TORX PLUS®-Schlüssel TORX PLUS® Wrench
B109...	6.075T15P	T15PQ

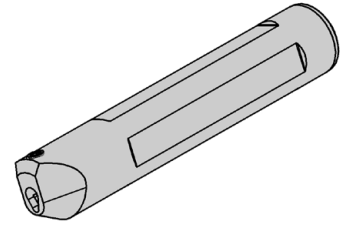
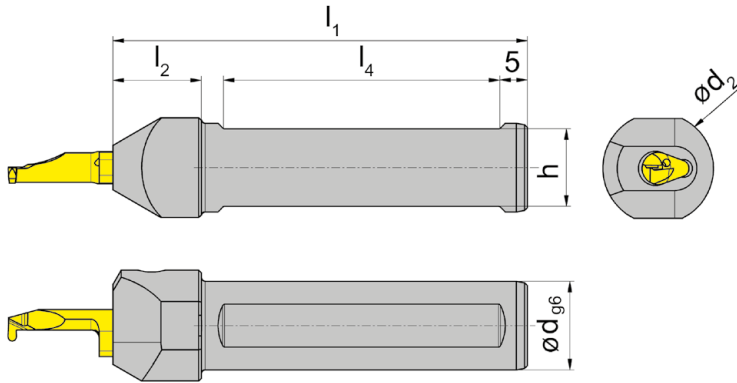
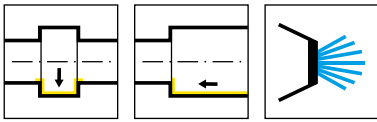

Abbildung = rechtsschneidend
Picture = right hand cutting version

Bestellnummer Part number	d	l ₁	h	l ₂	HWS
B109.0022.1.2.01	22	120	20	72	109140

Ersatzteile

Spare Parts

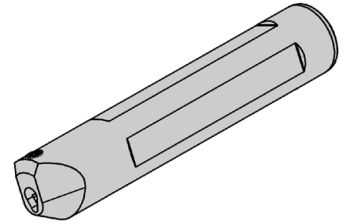
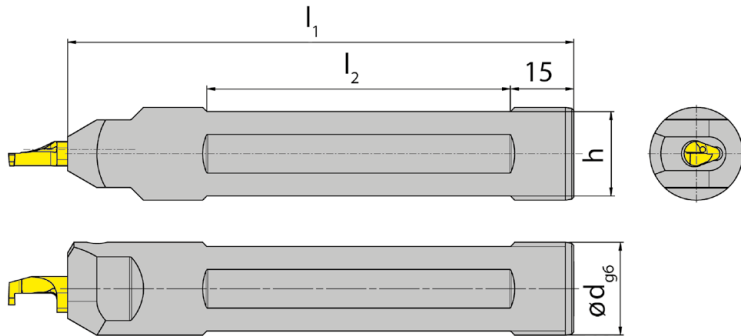
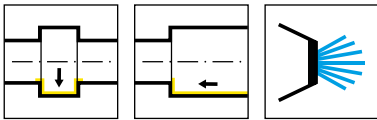
Klemmhalter Toolholder	Spannschraube Clamping Screw	TORX PLUS®-Schlüssel TORX PLUS® Wrench
B109.0022.1.2.01	6.075T15P	T15PQ

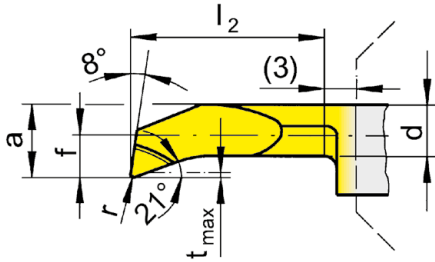
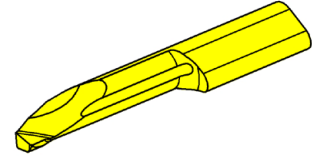
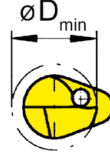
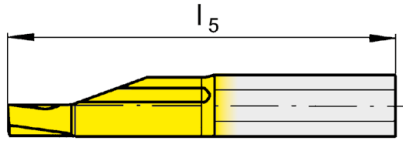
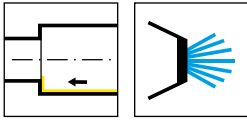

R = rechts wie gezeichnet
R = right hand version shown

L = links spiegelbildlich
L = left hand version

▲ ab Lager
on stock

HM-Sorten
Carbide grades
Δ 4 Wochen
4 weeks

Bestellnummer Part number	r	f	a	d	l ₂	l ₅	t _{max}	D _{min}	HIS	TH35
R109.1828.1.6	0,2	2,8	5,7	5	10	28	0,4	6	109140	Δ
R109.1828.2.6	0,2	2,8	5,7	5	15	33	0,4	6	109140	Δ
R109.1828.3.6	0,2	2,8	5,7	5	20	38	0,4	6	109140	▲
R109.1828.4.6	0,2	2,8	5,7	5	25	43	0,4	6	109140	Δ
R109.1828.5.6	0,2	2,8	5,7	5	30	48	0,4	6	109140	Δ
R109.1828.6.6	0,2	2,8	5,7	5	35	53	0,4	6	109140	Δ
R109.1828.7.6	0,2	2,8	5,7	5	40	58	0,4	6	109140	▲
R109.1838.2.7	0,2	3,8	6,7	6	15	33	0,4	7	109140	Δ
R109.1838.3.7	0,2	3,8	6,7	6	20	38	0,4	7	109140	Δ
R109.1838.4.7	0,2	3,8	6,7	6	25	43	0,4	7	109140	Δ
R109.1838.5.7	0,2	3,8	6,7	6	30	48	0,4	7	109140	▲
R109.1838.6.7	0,2	3,8	6,7	6	35	53	0,4	7	109140	▲
R109.1838.7.7	0,2	3,8	6,7	6	40	58	0,4	7	109140	▲
R109.1838.8.7	0,2	3,8	6,7	6	45	63	0,4	7	109140	▲
L109.1828.1.6	0,2	2,8	5,7	5	10	28	0,4	6	109140	Δ
L109.1828.2.6	0,2	2,8	5,7	5	15	33	0,4	6	109140	Δ
L109.1828.3.6	0,2	2,8	5,7	5	20	38	0,4	6	109140	Δ
L109.1828.5.6	0,2	2,8	5,7	5	30	48	0,4	6	109140	Δ
L109.1828.6.6	0,2	2,8	5,7	5	35	53	0,4	6	109140	Δ
L109.1828.7.6	0,2	2,8	5,7	5	40	58	0,4	6	109140	Δ
L109.1838.2.7	0,2	3,8	6,7	6	15	33	0,4	7	109140	Δ
L109.1838.3.7	0,2	3,8	6,7	6	20	38	0,4	7	109140	Δ
L109.1838.4.7	0,2	3,8	6,7	6	25	43	0,4	7	109140	Δ
L109.1838.5.7	0,2	3,8	6,7	6	30	48	0,4	7	109140	Δ
L109.1838.6.7	0,2	3,8	6,7	6	35	53	0,4	7	109140	Δ
L109.1838.7.7	0,2	3,8	6,7	6	40	58	0,4	7	109140	Δ
L109.1838.8.7	0,2	3,8	6,7	6	45	63	0,4	7	109140	Δ

P	●
M	●
K	●
N	●
S	●
H	-

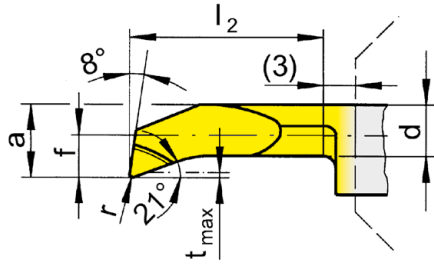
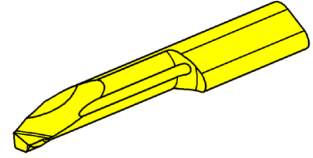
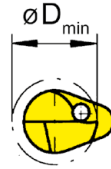
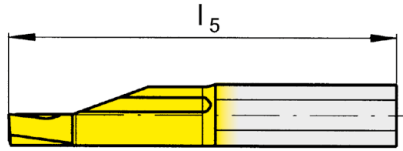
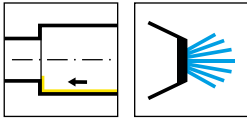

R = rechts wie gezeichnet
R = right hand version shown

L = links spiegelbildlich
L = left hand version

▲ ab Lager
on stock

HM-Sorten
Carbide grades
Δ 4 Wochen
4 weeks

Bestellnummer Part number	r	f	a	d	l ₂	l ₅	t _{max}	D _{min}	HIS	TH35
R109.1828.04.1.6	0,4	2,8	5,7	5	10	28	0,4	6	109140	Δ
R109.1828.04.2.6	0,4	2,8	5,7	5	15	33	0,4	6	109140	Δ
R109.1828.04.3.6	0,4	2,8	5,7	5	20	38	0,4	6	109140	Δ
R109.1828.04.4.6	0,4	2,8	5,7	5	25	43	0,4	6	109140	Δ
R109.1828.04.6.6	0,4	2,8	5,7	5	35	53	0,4	6	109140	Δ
R109.1828.04.7.6	0,4	2,8	5,7	5	40	58	0,4	6	109140	Δ
R109.1838.04.2.7	0,4	3,8	6,7	6	15	33	0,4	7	109140	Δ
R109.1838.04.3.7	0,4	3,8	6,7	6	20	38	0,4	7	109140	Δ
R109.1838.04.5.7	0,4	3,8	6,7	6	30	48	0,4	7	109140	Δ
R109.1838.04.8.7	0,4	3,8	6,7	6	45	63	0,4	7	109140	▲
L109.1828.04.1.6	0,4	2,8	5,7	5	10	28	0,4	6	109140	Δ
L109.1828.04.2.6	0,4	2,8	5,7	5	15	33	0,4	6	109140	Δ
L109.1828.04.3.6	0,4	2,8	5,7	5	20	38	0,4	6	109140	Δ
L109.1828.04.4.6	0,4	2,8	5,7	5	25	43	0,4	6	109140	Δ
L109.1828.04.6.6	0,4	2,8	5,7	5	35	53	0,4	6	109140	Δ
L109.1828.04.7.6	0,4	2,8	5,7	5	40	58	0,4	6	109140	Δ
L109.1838.04.2.7	0,4	3,8	6,7	6	15	33	0,4	7	109140	Δ
L109.1838.04.3.7	0,4	3,8	6,7	6	20	38	0,4	7	109140	Δ
L109.1838.04.8.7	0,4	3,8	6,7	6	45	63	0,4	7	109140	Δ

P	●
M	●
K	●
N	●
S	●
H	-

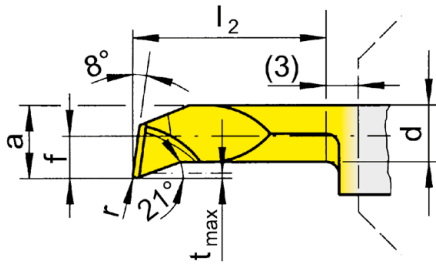
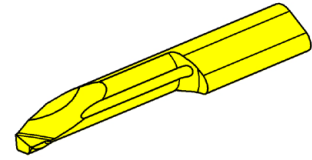
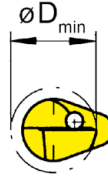
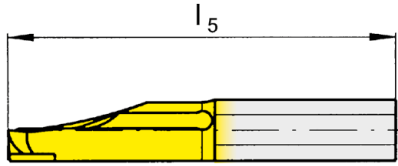
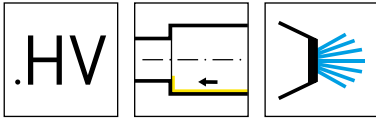

R = rechts wie gezeichnet
R = right hand version shown

L = links spiegelbildlich
L = left hand version

▲ ab Lager
on stock

HM-Sorten
Carbide grades
Δ 4 Wochen
4 weeks

Bestellnummer Part number	r	f	a	d	l ₂	l ₅	t _{max}	D _{min}	HIS	TH35
R109.1828.1.HV6	0,2	2,8	5,7	5	10	28	0,4	6	109140	Δ
R109.1828.2.HV6	0,2	2,8	5,7	5	15	33	0,4	6	109140	Δ
R109.1828.3.HV6	0,2	2,8	5,7	5	20	38	0,4	6	109140	Δ
R109.1828.4.HV6	0,2	2,8	5,7	5	25	43	0,4	6	109140	Δ
R109.1828.5.HV6	0,2	2,8	5,7	5	30	48	0,4	6	109140	▲
R109.1828.6.HV6	0,2	2,8	5,7	5	35	53	0,4	6	109140	▲
R109.1828.7.HV6	0,2	2,8	5,7	5	40	58	0,4	6	109140	▲
R109.1838.3.HV7	0,2	3,8	6,7	6	20	38	0,4	7	109140	Δ
R109.1838.5.HV7	0,2	3,8	6,7	6	30	48	0,4	7	109140	Δ
R109.1838.6.HV7	0,2	3,8	6,7	6	35	53	0,4	7	109140	Δ
R109.1838.7.HV7	0,2	3,8	6,7	6	40	58	0,4	7	109140	Δ
R109.1838.8.HV7	0,2	3,8	6,7	6	45	63	0,4	7	109140	Δ
L109.1828.1.HV6	0,2	2,8	5,7	5	10	28	0,4	6	109140	Δ
L109.1828.2.HV6	0,2	2,8	5,7	5	15	33	0,4	6	109140	Δ
L109.1828.3.HV6	0,2	2,8	5,7	5	20	38	0,4	6	109140	Δ
L109.1828.4.HV6	0,2	2,8	5,7	5	25	43	0,4	6	109140	Δ
L109.1828.6.HV6	0,2	2,8	5,7	5	35	53	0,4	6	109140	Δ
L109.1828.7.HV6	0,2	2,8	5,7	5	40	58	0,4	6	109140	Δ
L109.1838.2.HV7	0,2	3,8	6,7	6	15	33	0,4	7	109140	Δ
L109.1838.5.HV7	0,2	3,8	6,7	6	30	48	0,4	7	109140	Δ
L109.1838.6.HV7	0,2	3,8	6,7	6	35	53	0,4	7	109140	Δ
L109.1838.7.HV7	0,2	3,8	6,7	6	40	58	0,4	7	109140	Δ
L109.1838.8.HV7	0,2	3,8	6,7	6	45	63	0,4	7	109140	Δ

P	●
M	●
K	●
N	●
S	●
H	-

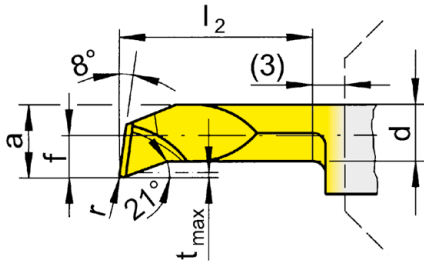
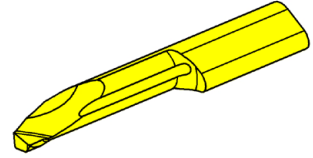
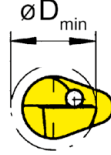
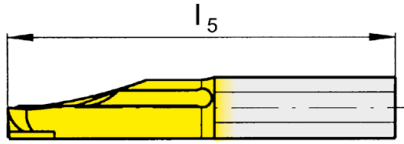
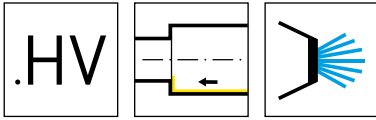

R = rechts wie gezeichnet
R = right hand version shown

L = links spiegelbildlich
L = left hand version

HM-Sorten
Carbide grades
▲ ab Lager
on stock
Δ 4 Wochen
4 weeks

Bestellnummer Part number	r	f	a	d	l ₂	l ₅	t _{max}	D _{min}	HIS	TH35
R109.1828.04.1.HV6	0,4	2,8	5,7	5	10	28	0,4	6	109140	Δ
R109.1828.04.2.HV6	0,4	2,8	5,7	5	15	33	0,4	6	109140	Δ
R109.1828.04.3.HV6	0,4	2,8	5,7	5	20	38	0,4	6	109140	Δ
R109.1828.04.4.HV6	0,4	2,8	5,7	5	25	43	0,4	6	109140	Δ
R109.1828.04.5.HV6	0,4	2,8	5,7	5	30	48	0,4	6	109140	Δ
R109.1828.04.6.HV6	0,4	2,8	5,7	5	35	53	0,4	6	109140	Δ
R109.1828.04.7.HV6	0,4	2,8	5,7	5	40	58	0,4	6	109140	Δ
R109.1838.04.2.HV7	0,4	3,8	6,7	6	15	33	0,4	7	109140	Δ
R109.1838.04.3.HV7	0,4	3,8	6,7	6	20	38	0,4	7	109140	Δ
R109.1838.04.4.HV7	0,4	3,8	6,7	6	25	43	0,4	7	109140	Δ
R109.1838.04.5.HV7	0,4	3,8	6,7	6	30	48	0,4	7	109140	Δ
R109.1838.04.6.HV7	0,4	3,8	6,7	6	35	53	0,4	7	109140	Δ
R109.1838.04.7.HV7	0,4	3,8	6,7	6	40	58	0,4	7	109140	Δ
R109.1838.04.8.HV7	0,4	3,8	6,7	6	45	63	0,4	7	109140	▲
L109.1828.04.1.HV6	0,4	2,8	5,7	5	10	28	0,4	6	109140	Δ
L109.1828.04.2.HV6	0,4	2,8	5,7	5	15	33	0,4	6	109140	Δ
L109.1828.04.4.HV6	0,4	2,8	5,7	5	25	43	0,4	6	109140	Δ
L109.1828.04.5.HV6	0,4	2,8	5,7	5	30	48	0,4	6	109140	Δ
L109.1828.04.6.HV6	0,4	2,8	5,7	5	35	53	0,4	6	109140	Δ
L109.1828.04.7.HV6	0,4	2,8	5,7	5	40	58	0,4	6	109140	Δ
L109.1838.04.2.HV7	0,4	3,8	6,7	6	15	33	0,4	7	109140	Δ
L109.1838.04.3.HV7	0,4	3,8	6,7	6	20	38	0,4	7	109140	Δ
L109.1838.04.4.HV7	0,4	3,8	6,7	6	25	43	0,4	7	109140	Δ
L109.1838.04.5.HV7	0,4	3,8	6,7	6	30	48	0,4	7	109140	Δ
L109.1838.04.6.HV7	0,4	3,8	6,7	6	35	53	0,4	7	109140	Δ
L109.1838.04.7.HV7	0,4	3,8	6,7	6	40	58	0,4	7	109140	Δ

P	●
M	●
K	●
N	●
S	●
H	-

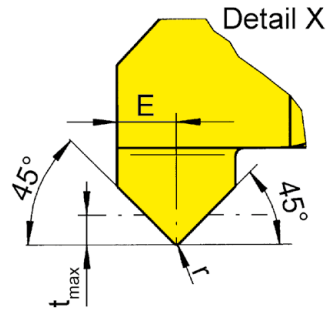
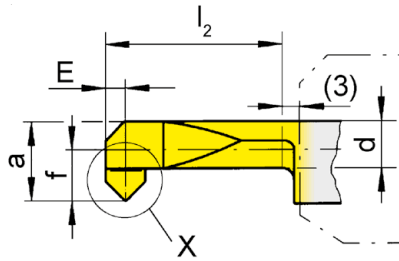
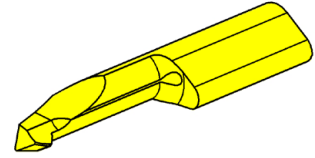
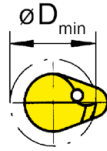
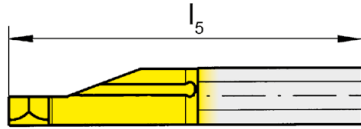
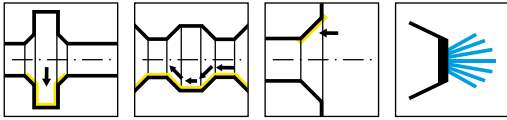

R = rechts wie gezeichnet
R = right hand version shown

L = links spiegelbildlich
L = left hand version

▲ ab Lager
on stock

HM-Sorten
Carbide grades
Δ 4 Wochen
4 weeks

Bestellnummer Part number	r	f	E	a	d	l ₂	l ₅	t _{max}	D _{min}	HIS	TH35
R109.4545.3.6	0,2	2,8	1,2	5,7	4,3	20	38	0,9	6	109140	Δ
R109.4545.5.7	0,2	3,8	1,2	6,7	5,3	30	48	0,9	7	109140	▲
L109.4545.3.6	0,2	2,8	1,2	5,7	4,3	20	38	0,9	6	109140	Δ
L109.4545.5.7	0,2	3,8	1,2	6,7	5,3	30	48	0,9	7	109140	Δ

P	●
M	●
K	●
N	●
S	●
H	-

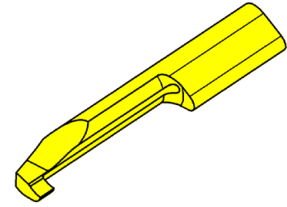
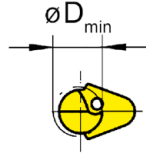
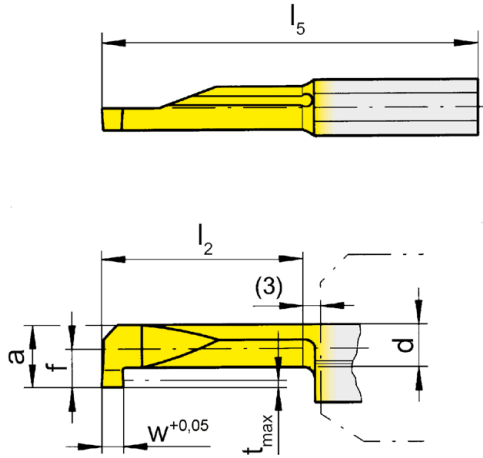
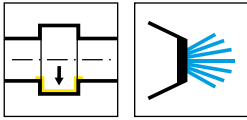

R = rechts wie gezeichnet
R = right hand version shown

L = links spiegelbildlich
L = left hand version

▲ ab Lager
on stock

HM-Sorten
Carbide grades
Δ 4 Wochen
4 weeks

Bestellnummer Part number	w	f	a	d	l ₂	l ₅	t _{max}	D _{min}	HIS	TH35
R109.0100.1.6	1	2,8	5,7	3,7	10	28	1,8	6	109140	Δ
R109.0150.1.6	1,5	2,8	5,7	3,7	10	28	1,8	6	109140	Δ
R109.0200.1.6	2	2,8	5,7	3,7	10	28	1,8	6	109140	Δ
R109.0100.2.6	1	2,8	5,7	3,7	15	33	1,8	6	109140	Δ
R109.0150.2.6	1,5	2,8	5,7	3,7	15	33	1,8	6	109140	Δ
R109.0200.2.6	2	2,8	5,7	3,7	15	33	1,8	6	109140	Δ
R109.0100.3.6	1	2,8	5,7	3,7	20	38	1,8	6	109140	Δ
R109.0150.3.6	1,5	2,8	5,7	3,7	20	38	1,8	6	109140	Δ
R109.0200.3.6	2	2,8	5,7	3,7	20	38	1,8	6	109140	Δ
L109.0100.1.6	1	2,8	5,7	3,7	10	28	1,8	6	109140	Δ
L109.0150.1.6	1,5	2,8	5,7	3,7	10	28	1,8	6	109140	Δ
L109.0200.1.6	2	2,8	5,7	3,7	10	28	1,8	6	109140	Δ
L109.0100.2.6	1	2,8	5,7	3,7	15	33	1,8	6	109140	Δ
L109.0150.2.6	1,5	2,8	5,7	3,7	15	33	1,8	6	109140	Δ
L109.0200.2.6	2	2,8	5,7	3,7	15	33	1,8	6	109140	Δ
L109.0100.3.6	1	2,8	5,7	3,7	20	38	1,8	6	109140	Δ
L109.0150.3.6	1,5	2,8	5,7	3,7	20	38	1,8	6	109140	Δ
L109.0200.3.6	2	2,8	5,7	3,7	20	38	1,8	6	109140	Δ

P	●
M	●
K	●
N	●
S	●
H	-

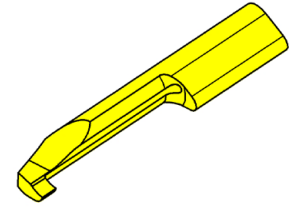
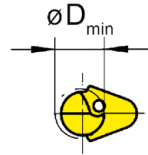
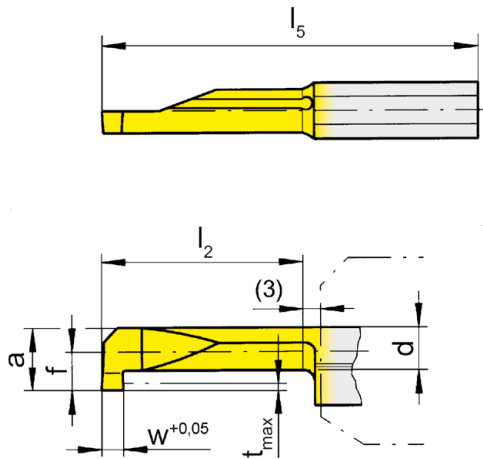
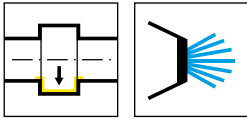

R = rechts wie gezeichnet
R = right hand version shown

L = links spiegelbildlich
L = left hand version

▲ ab Lager
on stock

HM-Sorten
Carbide grades
Δ 4 Wochen
4 weeks

Bestellnummer Part number	w	f	a	d	l_2	l_5	t_{max}	D_{min}	HIS	TH35
R109.0150.4.6	1,5	2,8	5,7	3,7	25	43	1,8	6	109140	Δ
R109.0150.5.6	1,5	2,8	5,7	3,7	30	48	1,8	6	109140	Δ
R109.0150.6.6	1,5	2,8	5,7	3,7	35	53	1,8	6	109140	Δ
R109.0200.1.6	2	2,8	5,7	3,7	10	28	1,8	6	109140	Δ
R109.0200.2.6	2	2,8	5,7	3,7	15	33	1,8	6	109140	Δ
R109.0200.3.6	2	2,8	5,7	3,7	20	38	1,8	6	109140	Δ
R109.0200.4.6	2	2,8	5,7	3,7	25	43	1,8	6	109140	Δ
R109.0200.5.6	2	2,8	5,7	3,7	30	48	1,8	6	109140	Δ
R109.0200.6.6	2	2,8	5,7	3,7	35	53	1,8	6	109140	▲
L109.0150.6.6	1,5	2,8	5,7	3,7	35	53	1,8	6	109140	Δ
L109.0200.1.6	2	2,8	5,7	3,7	10	28	1,8	6	109140	Δ
L109.0200.2.6	2	2,8	5,7	3,7	15	33	1,8	6	109140	Δ
L109.0200.3.6	2	2,8	5,7	3,7	20	38	1,8	6	109140	Δ
L109.0200.4.6	2	2,8	5,7	3,7	25	43	1,8	6	109140	Δ
L109.0200.6.6	2	2,8	5,7	3,7	35	53	1,8	6	109140	Δ
P	●									
M	●									
K	●									
N	●									
S	●									
H	-									

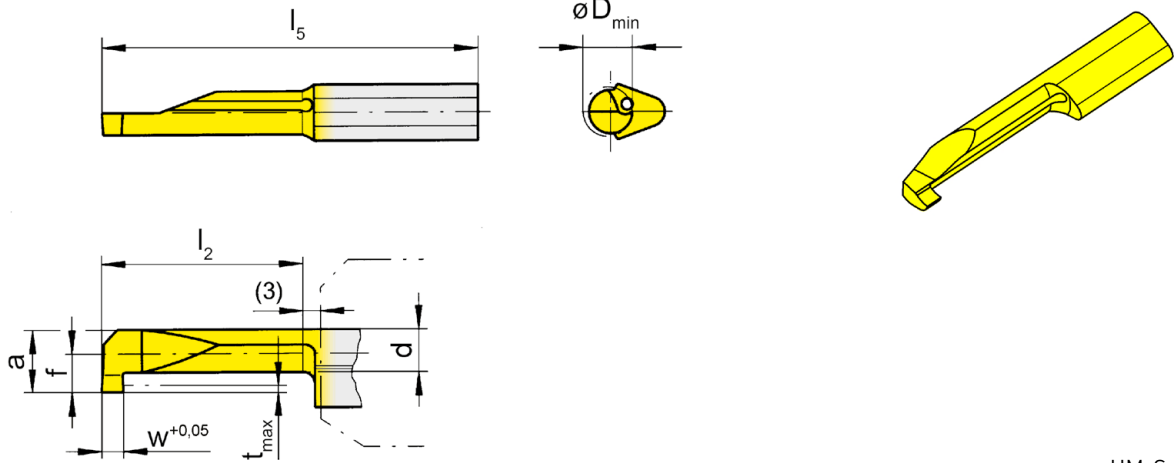
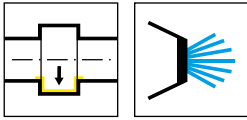

R = rechts wie gezeichnet
R = right hand version shown

L = links spiegelbildlich
L = left hand version

HM-Sorten
Carbide grades
▲ ab Lager
on stock
Δ 4 Wochen
4 weeks

Bestellnummer Part number	w	f	a	d	l ₂	l ₅	t _{max}	D _{min}	HIS	TH35
R109.0100.1.7	1	3,8	6,7	4	10	28	2,5	7	109140	Δ
R109.0150.1.7	1,5	3,8	6,7	4	10	28	2,5	7	109140	Δ
R109.0200.1.7	2	3,8	6,7	4	10	28	2,5	7	109140	▲
R109.0100.2.7	1	3,8	6,7	4	15	33	2,5	7	109140	Δ
R109.0150.2.7	1,5	3,8	6,7	4	15	33	2,5	7	109140	▲
R109.0200.2.7	2	3,8	6,7	4	15	33	2,5	7	109140	▲
R109.0100.3.7	1	3,8	6,7	4	20	38	2,5	7	109140	Δ
R109.0150.3.7	1,5	3,8	6,7	4	20	38	2,5	7	109140	Δ
R109.0200.3.7	2	3,8	6,7	4	20	38	2,5	7	109140	Δ
L109.0100.1.7	1	3,8	6,7	4	10	28	2,5	7	109140	Δ
L109.0150.1.7	1,5	3,8	6,7	4	10	28	2,5	7	109140	Δ
L109.0200.1.7	2	3,8	6,7	4	10	28	2,5	7	109140	Δ
L109.0100.2.7	1	3,8	6,7	4	15	33	2,5	7	109140	Δ
L109.0150.2.7	1,5	3,8	6,7	4	15	33	2,5	7	109140	Δ
L109.0200.2.7	2	3,8	6,7	4	15	33	2,5	7	109140	Δ
L109.0100.3.7	1	3,8	6,7	4	20	38	2,5	7	109140	Δ
L109.0200.3.7	2	3,8	6,7	4	20	38	2,5	7	109140	Δ

P	●
M	●
K	●
N	●
S	●
H	-

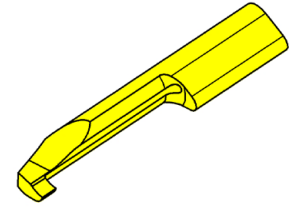
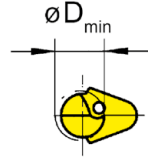
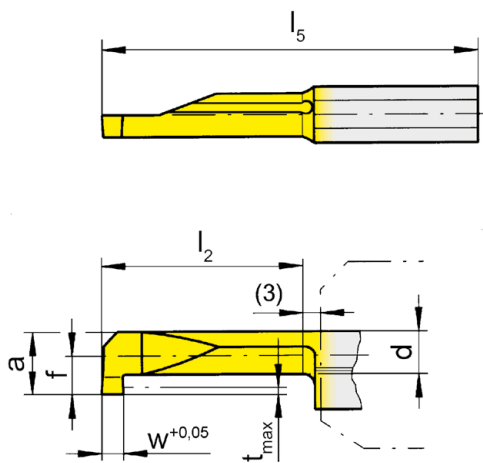
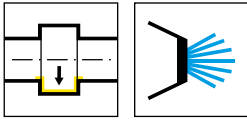

R = rechts wie gezeichnet
R = right hand version shown

L = links spiegelbildlich
L = left hand version

▲ ab Lager
on stock

HM-Sorten
Carbide grades
Δ 4 Wochen
4 weeks

Bestellnummer Part number	w	f	a	d	l ₂	l ₅	t _{max}	D _{min}	HIS	TH35
R109.0150.4.7	1,5	3,8	6,7	4	25	43	2,5	7	109140	Δ
R109.0150.5.7	1,5	3,8	6,7	4	30	48	2,5	7	109140	Δ
R109.0150.6.7	1,5	3,8	6,7	4	35	53	2,5	7	109140	Δ
R109.0200.1.7	2	3,8	6,7	4	10	28	2,5	7	109140	▲
R109.0200.2.7	2	3,8	6,7	4	15	33	2,5	7	109140	▲
R109.0200.3.7	2	3,8	6,7	4	20	38	2,5	7	109140	Δ
R109.0200.4.7	2	3,8	6,7	4	25	43	2,5	7	109140	Δ
R109.0200.5.7	2	3,8	6,7	4	30	48	2,5	7	109140	▲
R109.0200.6.7	2	3,8	6,7	4	35	53	2,5	7	109140	▲
L109.0150.4.7	1,5	3,8	6,7	4	25	43	2,5	7	109140	Δ
L109.0150.5.7	1,5	3,8	6,7	4	30	48	2,5	7	109140	Δ
L109.0150.6.7	1,5	3,8	6,7	4	35	53	2,5	7	109140	Δ
L109.0200.1.7	2	3,8	6,7	4	10	28	2,5	7	109140	Δ
L109.0200.2.7	2	3,8	6,7	4	15	33	2,5	7	109140	Δ
L109.0200.3.7	2	3,8	6,7	4	20	38	2,5	7	109140	Δ
L109.0200.4.7	2	3,8	6,7	4	25	43	2,5	7	109140	Δ
L109.0200.5.7	2	3,8	6,7	4	30	48	2,5	7	109140	Δ
L109.0200.6.7	2	3,8	6,7	4	35	53	2,5	7	109140	Δ

P	●
M	●
K	●
N	●
S	●
H	-

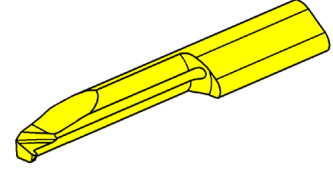
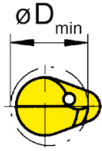
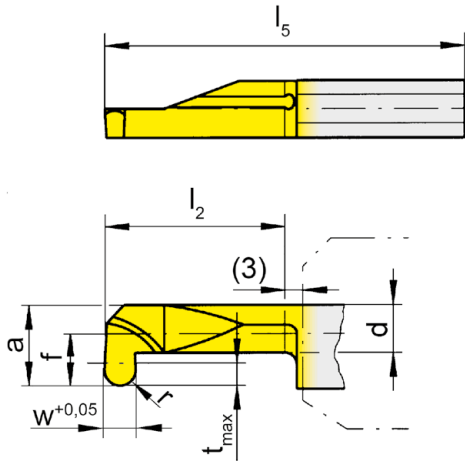
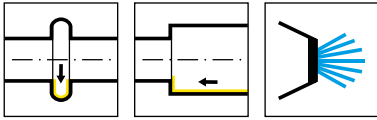

R = rechts wie gezeichnet
R = right hand version shown

L = links spiegelbildlich
L = left hand version

▲ ab Lager
on stock

HM-Sorten
Carbide grades
Δ 4 Wochen
4 weeks

Bestellnummer Part number	w	r	f	a	d	l_2	l_5	t_{max}	D_{min}	HIS	TH35
R109.0005.4.6	1	0,5	2,8	5,7	3,7	25	43	1,8	6	109140	Δ
R109.0007.4.6	1,5	0,75	2,8	5,7	3,7	25	43	1,8	6	109140	Δ
R109.0010.4.6	2	1	2,8	5,7	3,7	25	43	1,8	6	109140	Δ
R109.0005.6.7	1	0,5	3,8	6,7	4	35	53	2,5	7	109140	Δ
R109.0007.6.7	1,5	0,75	3,8	6,7	4	35	53	2,5	7	109140	Δ
R109.0010.6.7	2	1	3,8	6,7	4	35	53	2,5	7	109140	▲
L109.0005.4.6	1	0,5	2,8	5,7	3,7	25	43	1,8	6	109140	Δ
L109.0007.4.6	1,5	0,75	2,8	5,7	3,7	25	43	1,8	6	109140	Δ
L109.0010.4.6	2	1	2,8	5,7	3,7	25	43	1,8	6	109140	Δ
L109.0005.6.7	1	0,5	3,8	6,7	4	35	53	2,5	7	109140	Δ
L109.0007.6.7	1,5	0,75	3,8	6,7	4	35	53	2,5	7	109140	Δ
L109.0010.6.7	2	1	3,8	6,7	4	35	53	2,5	7	109140	Δ
											P ●
											M ●
											K ●
											N ●
											S ●
											H -

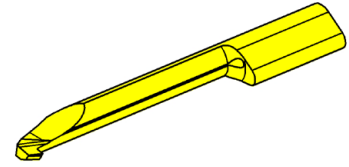
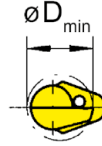
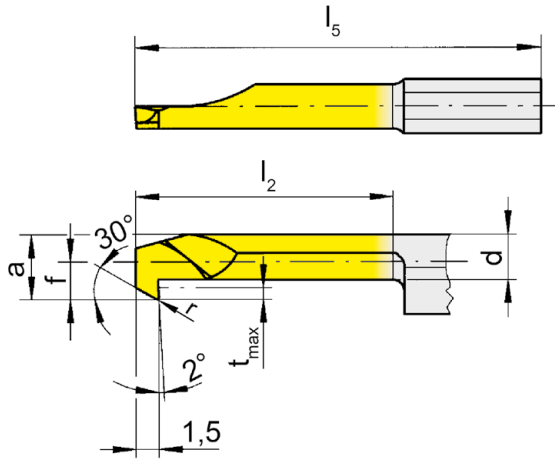
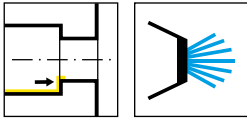

R = rechts wie gezeichnet
R = right hand version shown

L = links spiegelbildlich
L = left hand version

▲ ab Lager
on stock

HM-Sorten
Carbide grades
Δ 4 Wochen
4 weeks

Bestellnummer Part number	r	f	a	d	l ₂	l ₅	t _{max}	D _{min}	HIS	TH35
R109.3028.3.6	0,2	2,8	5,7	3,7	20	38	1,8	6	109140	Δ
R109.3028.5.6	0,2	2,8	5,7	3,7	30	48	1,8	6	109140	Δ
R109.3038.3.7	0,2	3,8	6,7	4	20	38	2,5	7	109140	▲
R109.3038.5.7	0,2	3,8	6,7	4	30	48	2,5	7	109140	▲
L109.3028.3.6	0,2	2,8	5,7	3,7	20	38	1,8	6	109140	Δ
L109.3028.5.6	0,2	2,8	5,7	3,7	30	48	1,8	6	109140	Δ
L109.3038.3.7	0,2	3,8	6,7	4	20	38	2,5	7	109140	Δ
										P ●
										M ●
										K ●
										N ●
										S ●
										H -

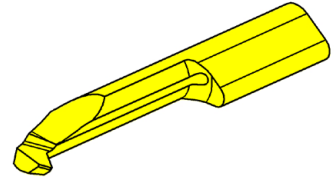
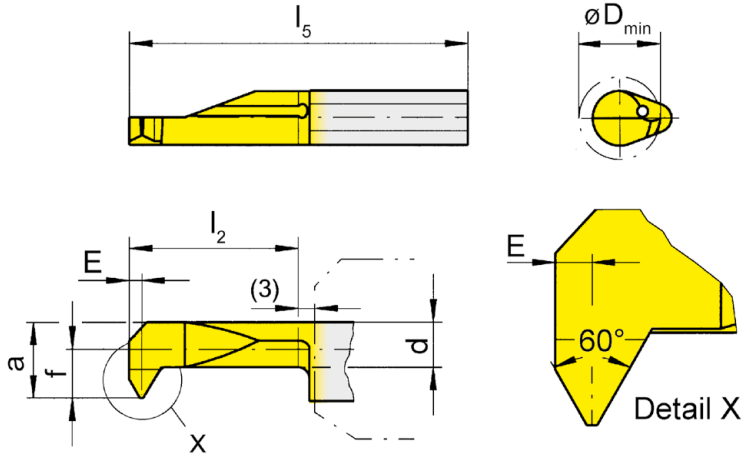
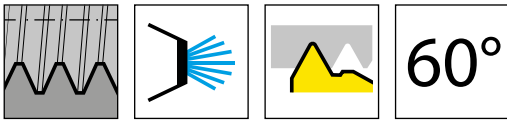

R = rechts wie gezeichnet
R = right hand version shown

L = links spiegelbildlich
L = left hand version

▲ ab Lager
on stock

HM-Sorten
Carbide grades
Δ 4 Wochen
4 weeks

Bestellnummer Part number	P	P _{max}	E	f	a	d	l ₂	l ₅	D _{min}	HIS	TH35
R109.0815.1.7	1,5	1,75	0,9	3,8	6,7	5,1	10	28	7	109140	Δ
R109.0815.3.7	1,5	1,75	0,9	3,8	6,7	5,1	20	38	7	109140	▲
R109.0815.5.7	1,5	1,75	0,9	3,8	6,7	5,1	30	48	7	109140	▲
L109.0815.1.7	1,5	1,75	0,9	3,8	6,7	5,1	10	28	7	109140	Δ
L109.0815.3.7	1,5	1,75	0,9	3,8	6,7	5,1	20	38	7	109140	Δ
L109.0815.5.7	1,5	1,75	0,9	3,8	6,7	5,1	30	48	7	109140	Δ

P	●
M	●
K	●
N	●
S	●
H	-

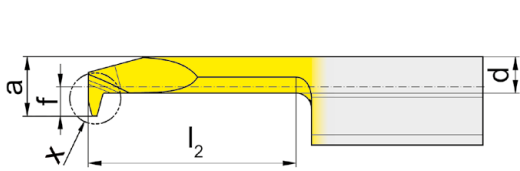
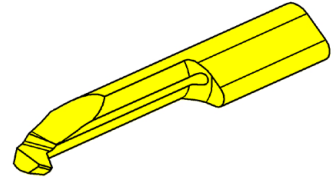
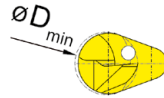
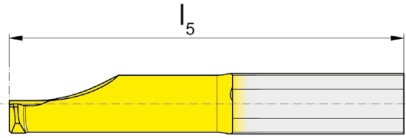
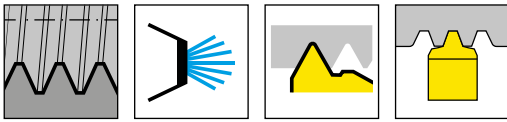

Detail X

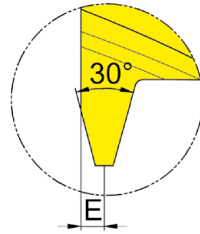

R = rechts wie gezeichnet, nur Rechtsgewinde herstellbar
R = right hand version shown, only right-hand thread can be produced

▲ ab Lager
on stock

HM-Sorten
Carbide grades
Δ 4 Wochen
4 weeks

Bestellnummer Part number	P	E	f	a	d	l_2	l_5	D_{min}	HIS	TH35
R109.0915.3.6	1,5	0,6	2,8	5,7	3,5	20	38	6	109140	▲
R109.1220.3.6	2	0,8	2,8	5,7	3,5	20	38	6	109140	▲
R109.1220.3.7	2	0,8	3,8	6,7	4,8	20	38	7	109140	▲
R109.1220.5.7	2	0,8	3,8	6,7	4,8	30	48	7	109140	▲
R109.1730.3.7	3	1,2	3,8	6,7	4,3	20	38	7	109140	▲
	P	●								
	M	●								
	K	●								
	N	●								
	S	●								
	H	-								

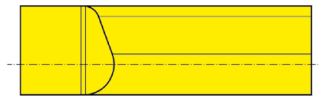
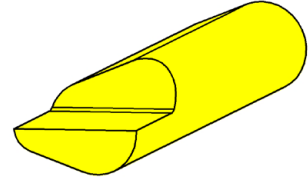
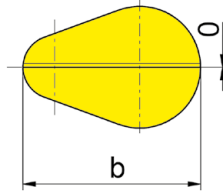
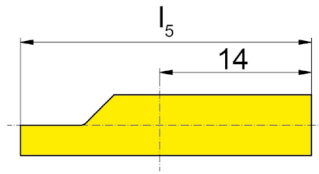
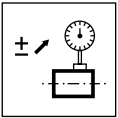

R = rechts wie gezeichnet
R = right hand version shown

L = links spiegelbildlich
L = left hand version

▲ ab Lager
on stock

HM-Sorten
Carbide grades
Δ 4 Wochen
4 weeks

Bestellnummer Part number	b	l ₅	HIS	MG12
R109.LEHR.H.01	8,5	28	109140	Δ
L109.LEHR.H.01	8,5	28	109140	Δ

Platte zum Einrichten des Werkzeugs
Insert for tool set up

P	o
M	-
K	-
N	-
S	-
H	-

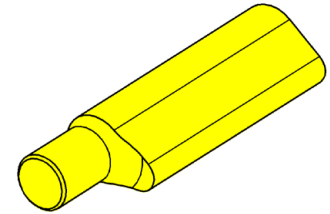
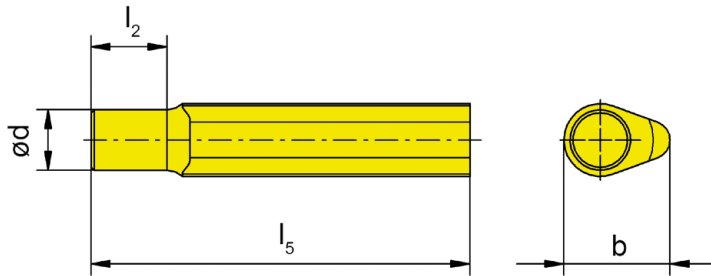
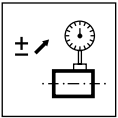

Bestellnummer Part number	d	b	l_2	l_5	HIS
109.LEHR.D.01	4,5	8,5	5	25	109140

Platte zum Einrichten des Werkzeugs
Insert for tool set up

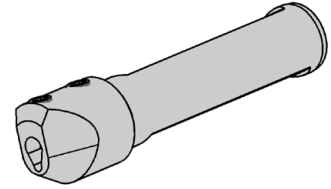
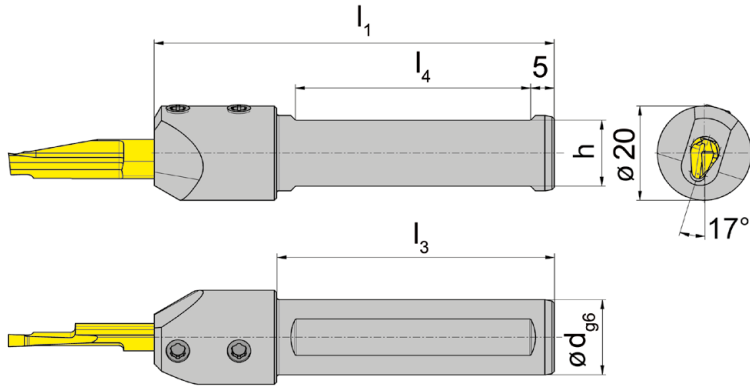
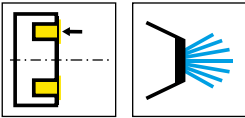

R = rechts wie gezeichnet
R = right hand version shown

L = links spiegelbildlich
L = left hand version

Bestellnummer Part number	d	l ₁	l ₃	h	l ₄	HWS
RB109.0016.14.2	16	85	59	14	50	109240
LB109.0016.14.2	16	85	59	14	50	109240

Ersatzteile

Spare Parts

Klemmhalter Toolholder	Spannschraube Clamping Screw	TORX PLUS®-Schlüssel TORX PLUS® Wrench
R/LB109.0016.14.2	6.075T15P	T15PQ

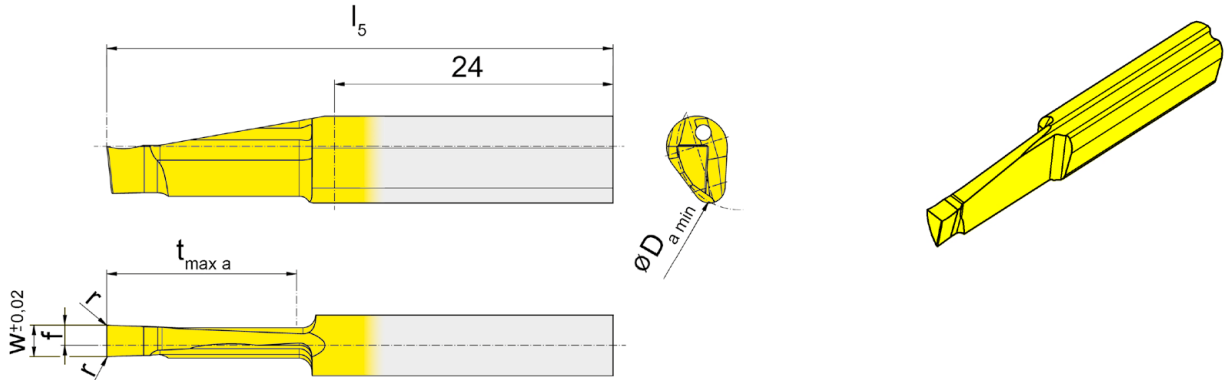
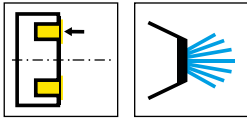

L = links wie gezeichnet
L = left hand version shown

R = rechts spiegelbildlich
R = right hand version

▲ ab Lager
on stock

HM-Sorten
Carbide grades
Δ 4 Wochen
4 weeks

Bestellnummer Part number	w	r	f	l_5	$t_{max a}$	$D_{a min}$	HIS	T125
RA109.1520.3.2	2	0,1	1	48	20	15	109240	▲
RA109.1525.3.2	2,5	0,1	1,2	48	20	15	109240	▲
RA109.1530.3.2	3	0,1	1,5	48	20	15	109240	▲
LA109.1520.3.2	2	0,1	1	48	20	15	109240	Δ
LA109.1525.3.2	2,5	0,1	1,2	48	20	15	109240	Δ
LA109.1530.3.2	3	0,1	1,5	48	20	15	109240	▲

Axialstechen ins Volle bei voller Stechtiefe nur bei $D_{a min}$ 15 - 40 mm möglich!
Face grooving with full width of the full depth only possible between $D_{a min}$ 15 - 40 mm!

P	●
M	●
K	●
N	●
S	●
H	-

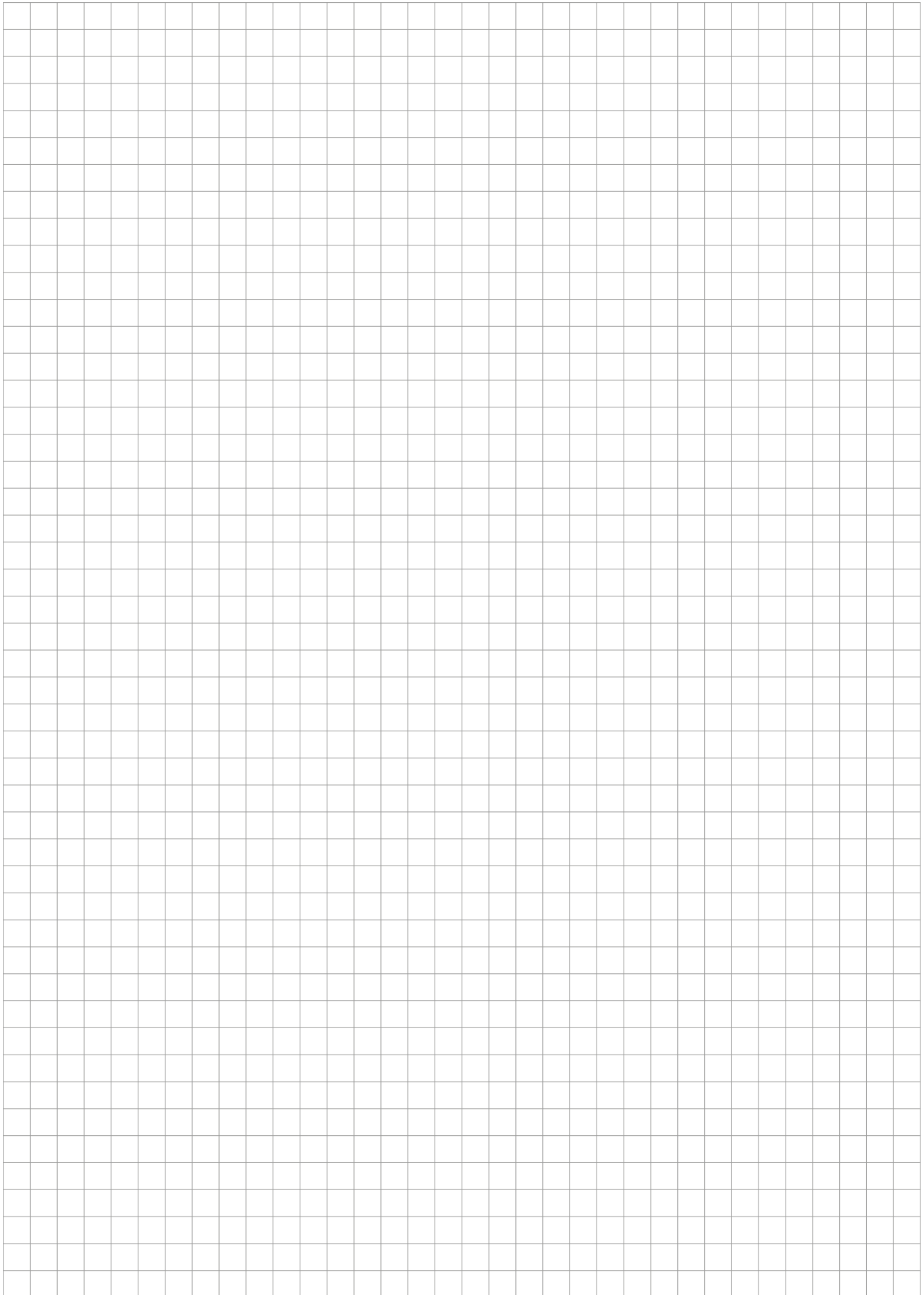

Supermini



- CVD-Dickschicht

- PKD-bestückt

- CBN-bestückt

- CVD-D

- PCD tipped

- PCBN tipped

Schneidplatte
Insert
105

PKD
PCD

Seite/Page
177-181

CVD-D

Seite/Page
182-184

CBN
PCBN

Seite/Page
185-188

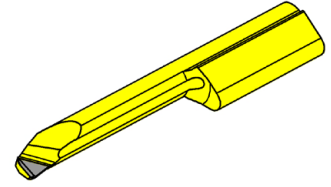
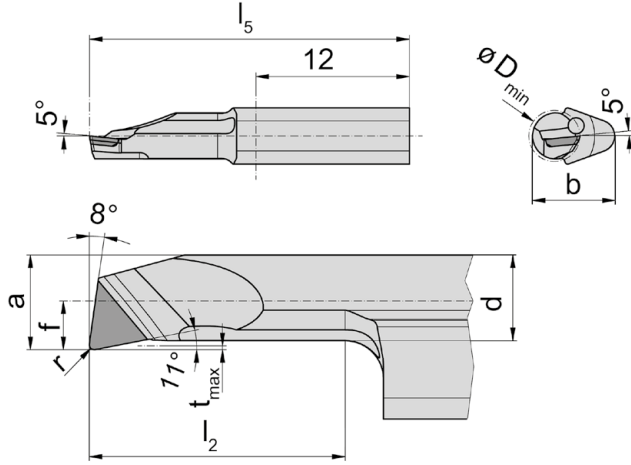
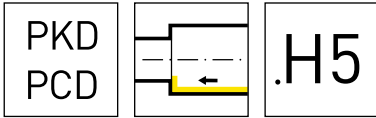

R = rechts wie gezeichnet
R = right hand version shown

HM-Sorten
Carbide grades
▲ ab Lager
on stock
Δ 4 Wochen
4 weeks

Bestellnummer Part number	r	f	a	d	b	l ₂	l ₅	t _{max}	D _{min}	HIS	PD75
R105.1002.1.3.H5.P	0,2	1,4	2,7	2,45	5,9	10	25	0,15	3	105123	▲
R105.1002.1.4.H5.P	0,2	1,9	3,7	3,35	6,4	10	25	0,15	4	105124	▲
R105.1002.1.5.H5.P	0,2	2,3	4,7	4,35	7	10	25	0,15	5	105125	▲
R105.1002.3.3.H5.P	0,2	1,4	2,7	2,45	5,9	20	35	0,15	3	105123	▲
R105.1002.3.4.H5.P	0,2	1,9	3,7	3,35	6,4	20	35	0,15	4	105124	▲
R105.1002.4.5.H5.P	0,2	2,3	4,7	4,35	7	25	40	0,15	5	105125	▲
R105.1004.1.5.H5.P	0,4	2,3	4,7	4,35	7	10	25	0,15	5	105125	▲
R105.1004.4.5.H5.P	0,4	2,3	4,7	4,35	7	25	40	0,15	5	105125	▲
											P -
											M -
											K -
											N ●
											S -
											H -

B

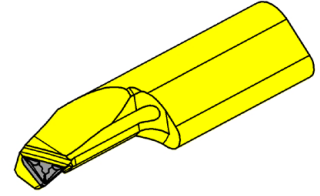
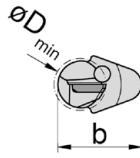
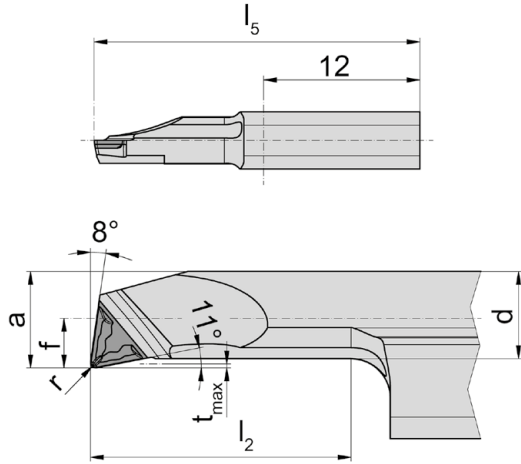
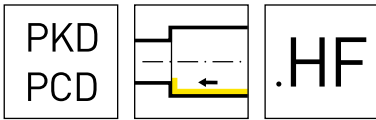

R = rechts wie gezeichnet
R = right hand version shown

HM-Sorten
Carbide grades
▲ ab Lager
on stock
Δ 4 Wochen
4 weeks

Bestellnummer Part number	r	f	a	d	b	l ₂	l ₅	t _{max}	D _{min}	HIS	PD75
R105.1002.1.4.HF.P	0,2	1,9	3,7	3,35	6,4	10	25	0,15	4	105124	▲
R105.1002.1.5.HF.P	0,2	2,3	4,7	4,35	7	10	25	0,15	5	105125	▲
R105.1002.3.4.HF.P	0,2	1,9	3,7	3,35	6,4	20	35	0,15	4	105124	▲
R105.1002.4.5.HF.P	0,2	2,3	4,7	4,35	7	25	40	0,15	5	105125	▲
R105.1004.1.5.HF.P	0,4	2,3	4,7	4,35	7	10	25	0,15	5	105125	▲
R105.1004.4.5.HF.P	0,4	2,3	4,7	4,35	7	25	40	0,15	5	105125	▲
											P -
											M -
											K -
											N ●
											S -
											H -

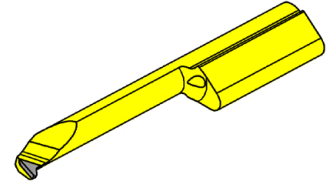
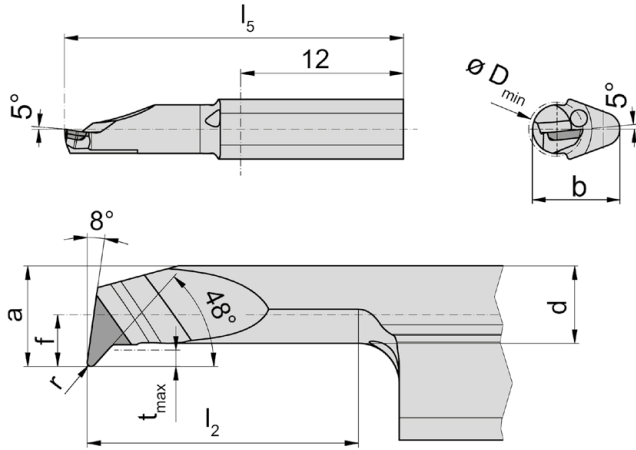
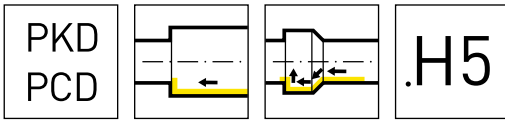

R = rechts wie gezeichnet
R = right hand version shown

HM-Sorten
Carbide grades
▲ ab Lager
on stock
Δ 4 Wochen
4 weeks

Bestellnummer Part number	r	f	a	d	b	l ₂	l ₅	t _{max}	D _{min}	HIS	PD75
R105.4701.1.4.H5.P	0,15	1,9	3,7	2,85	6,4	10	25	0,6	4	105124	▲
R105.4701.3.4.H5.P	0,15	1,9	3,7	2,85	6,4	20	35	0,6	4	105124	▲
R105.4701.3.6.H5.P	0,15	3,3	5,7	4,85	7	20	35	0,6	6	105125	▲
R105.4701.5.6.H5.P	0,15	3,3	5,7	4,85	7	30	45	0,6	6	105125	▲
											P -
											M -
											K -
											N ●
											S -
											H -

Schneidplatte

Insert

105



B

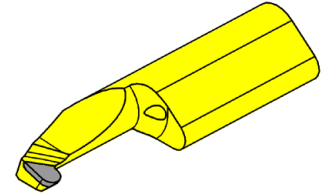
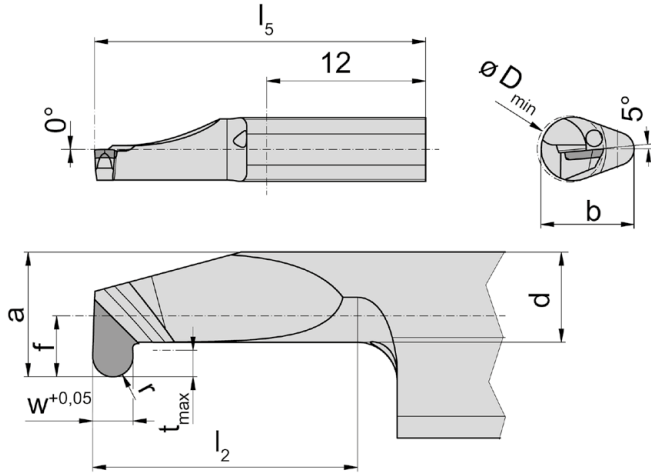
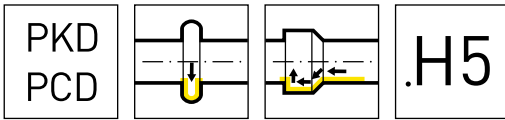

R = rechts wie gezeichnet
R = right hand version shown

HM-Sorten
Carbide grades
▲ ab Lager
on stock
Δ 4 Wochen
4 weeks

Bestellnummer Part number	w	r	f	a	d	b	l_2	l_5	t_{max}	D_{min}	HIS	PD75
R105.VR07.1.5.H5.P	1,5	0,75	2,3	4,7	3,4	7	10	25	1	5	105125	▲
												P -
												M -
												K -
												N ●
												S -
												H -

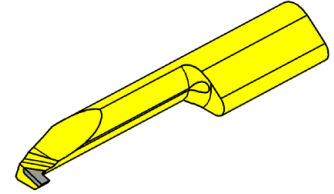
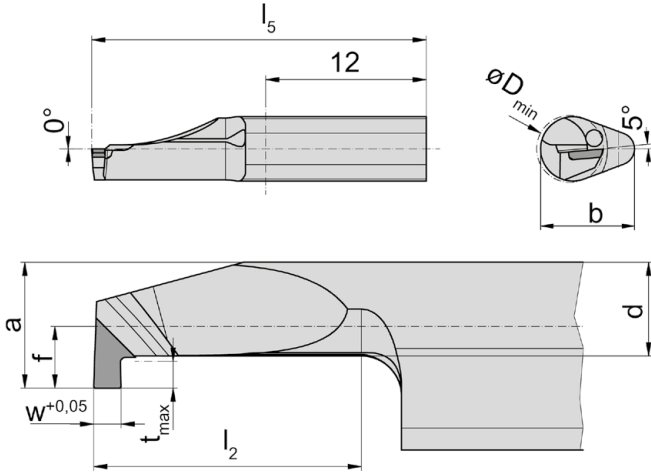
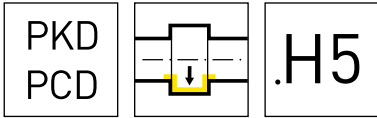

R = rechts wie gezeichnet
R = right hand version shown

HM-Sorten
Carbide grades
▲ ab Lager
on stock
Δ 4 Wochen
4 weeks

Bestellnummer Part number	w	f	a	d	b	l_2	l_5	t_{max}	D_{min}	HIS	PD75
R105.0100.1.5.H5.P	1	2,3	4,7	3,5	7	10	25	1	5	105125	▲
R105.0100.3.5.H5.P	1	2,3	4,7	3,5	7	20	35	1	5	105125	▲
R105.0100.5.5.H5.P	1	2,3	4,7	3,5	7	30	45	1	5	105125	▲
											P -
											M -
											K -
											N ●
											S -
											H -

B

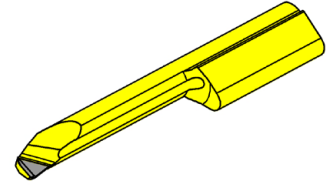
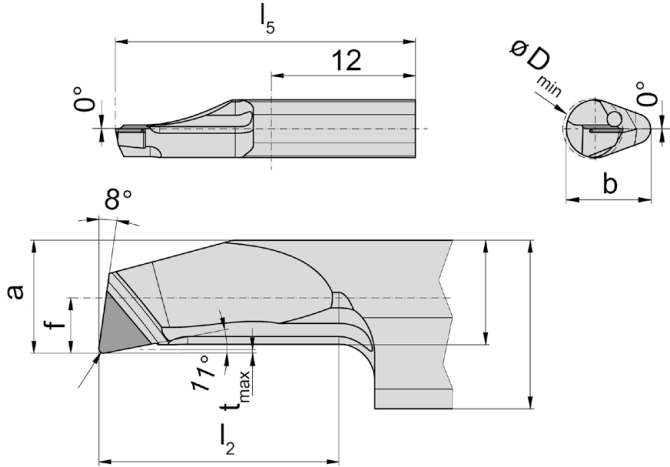
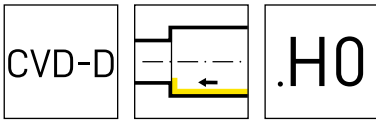

R = rechts wie gezeichnet
R = right hand version shown

▲ ab Lager
on stock

HM-Sorten
Carbide grades
Δ 4 Wochen
4 weeks

Bestellnummer Part number	r	f	a	d	b	l ₂	l ₅	t _{max}	D _{min}	HIS	HD03
R105.1001.0.15.H0.C	0,1	1,5	1,3	1,05	5,9	6	25	0,15	1,5	105123	▲
R105.1001.2.15.H0.C	0,1	1,5	1,3	1,05	5,9	12	30	0,15	1,5	105123	▲
R105.1001.0.2.H0.C	0,15	1,4	1,8	1,55	5,9	6	25	0,15	2	105123	▲
R105.1001.2.2.H0.C	0,15	1,4	1,8	1,55	5,9	12	30	0,15	2	105123	▲
R105.1002.1.3.H0.C	0,2	1,4	2,7	2,45	5,9	10	25	0,15	3	105123	▲
R105.1002.1.4.H0.C	0,2	1,9	3,7	3,35	6,4	10	25	0,15	4	105124	▲
R105.1002.1.5.H0.C	0,2	2,3	4,7	4,35	7	10	25	0,15	5	105125	▲
R105.1002.3.3.H0.C	0,2	1,4	2,7	2,45	5,9	20	35	0,15	3	105123	▲
R105.1002.3.4.H0.C	0,2	1,9	3,7	3,35	6,4	20	35	0,15	4	105124	▲
R105.1002.4.5.H0.C	0,2	2,3	4,7	4,35	7	25	40	0,15	5	105125	▲
R105.1004.1.5.H0.C	0,4	2,3	4,7	4,35	7	10	25	0,15	5	105125	▲
R105.1004.4.5.H0.C	0,4	2,3	4,7	4,35	7	25	40	0,15	5	105125	▲
											P -
											M -
											K -
											N ●
											S -
											H -

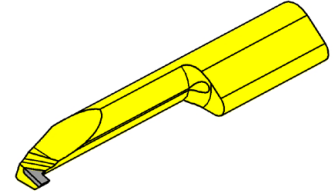
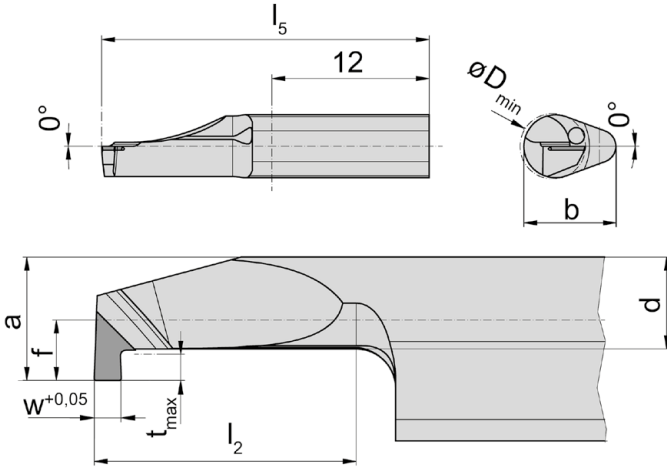
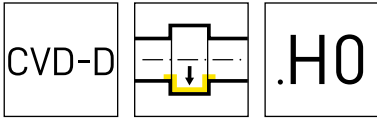

R = rechts wie gezeichnet
R = right hand version shown

HM-Sorten
Carbide grades
▲ ab Lager
on stock
Δ 4 Wochen
4 weeks

Bestellnummer Part number	w	f	a	d	b	l_2	l_5	t_{max}	D_{min}	HIS	HD03
R105.0100.1.5.H0.C	1	2,3	4,7	3,5	7	10	25	1	5	105125	▲
R105.0100.3.5.H0.C	1	2,3	4,7	3,5	7	20	35	1	5	105125	▲
R105.0100.5.5.H0.C	1	2,3	4,7	3,5	7	30	45	1	5	105125	▲
											P -
											M -
											K -
											N ●
											S -
											H -

Schneidplatte

Insert

105



B

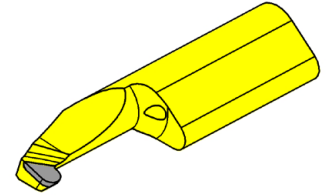
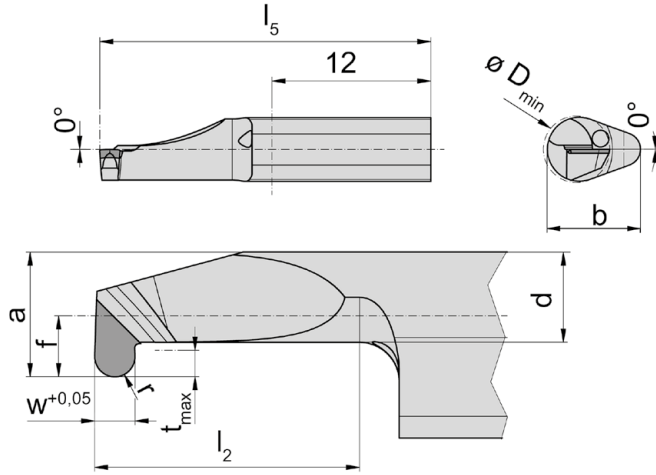
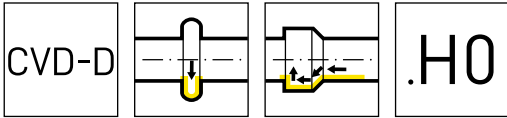

R = rechts wie gezeichnet
R = right hand version shown

HM-Sorten
Carbide grades
▲ ab Lager
on stock
Δ 4 Wochen
4 weeks

Bestellnummer Part number	w	r	f	a	d	b	l_2	l_5	t_{max}	D_{min}	HIS	HD03
R105.VR07.1.5.H0.C.	1,5	0,75	2,3	4,7	3,4	7	10	25	1	5	105125	▲
												P -
												M -
												K -
												N ●
												S -
												H -

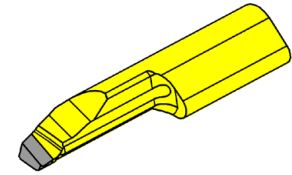
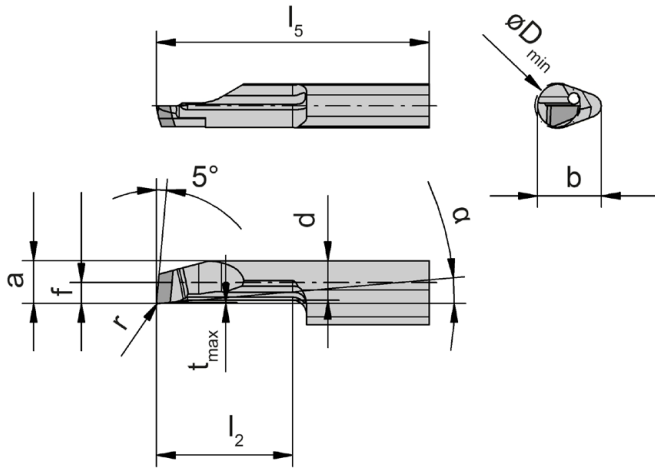
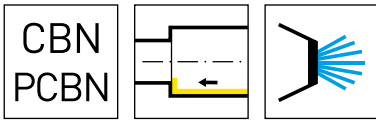

ISO Mat. Code



R = rechts wie gezeichnet
R = right hand version shown

L = links spiegelbildlich
L = left hand version

▲ ab Lager
on stock

HM-Sorten
Carbide grades
Δ 4 Wochen
4 weeks

Bestellnummer Part number	r	f	a	d	b	l ₂	l ₅	t _{max}	D _{min}	α	HIS	CB10	CB35
R105.1813.00.1.2.B	0,05	1,3	1,7	1,4	7	5	25	0,2	2	18°	105125	▲	▲
R105.1813.01.1.2.B	0,1	1,3	1,7	1,4	7	5	25	0,2	2	18°	105125	▲	▲
R105.0513.0.3.B	0,15	1,3	2,7	2,5	7	7	25	0,1	3	5°	105125	▲	
R105.1813.01.0.3.B	0,1	1,3	2,7	2,4	7	7	25	0,2	3	18°	105125	▲	▲
R105.1813.01.1.3.B	0,1	1,3	2,7	2,4	7	12	30	0,2	3	18°	105125	▲	▲
R105.1813.02.0.3.B	0,2	1,3	2,7	2,4	7	7	25	0,2	3	18°	105125	▲	▲
R105.1813.02.1.3.B	0,2	1,3	2,7	2,4	7	12	30	0,2	3	18°	105125	▲	▲
R105.0519.1.4.B	0,2	1,5	3,7	3,4	7	10	25	0,1	4	5°	105125	▲	
R105.1815.01.1.4.B	0,1	1,5	3,7	3,4	7	10	25	0,2	4	18°	105125	▲	▲
R105.1815.02.1.4.B	0,2	1,5	3,7	3,4	7	10	25	0,2	4	18°	105125	▲	▲
R105.1815.01.2.4.B	0,1	1,5	3,7	3,4	7	15	30	0,2	4	18°	105125	▲	▲
L105.1813.00.1.2.B	0,05	1,3	1,7	1,4	7	5	25	0,2	2	18°	105125	Δ	Δ
L105.1813.01.1.2.B	0,1	1,3	1,7	1,4	7	5	25	0,2	2	18°	105125	Δ	Δ
L105.1813.01.0.3.B	0,1	1,3	2,7	2,4	7	7	25	0,2	3	18°	105125	Δ	Δ
L105.1813.01.1.3.B	0,1	1,3	2,7	2,4	7	12	30	0,2	3	18°	105125	Δ	Δ
L105.1813.02.0.3.B	0,2	1,3	2,7	2,4	7	7	25	0,2	3	18°	105125	Δ	Δ
L105.1813.02.1.3.B	0,2	1,3	2,7	2,4	7	12	30	0,2	3	18°	105125	Δ	Δ
L105.1815.01.1.4.B	0,1	1,5	3,7	3,4	7	10	25	0,2	4	18°	105125	Δ	Δ
L105.1815.02.1.4.B	0,2	1,5	3,7	3,4	7	10	25	0,2	4	18°	105125	Δ	Δ
L105.1815.01.2.4.B	0,1	1,5	3,7	3,4	7	15	30	0,2	4	18°	105125	Δ	Δ

B

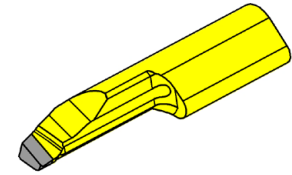
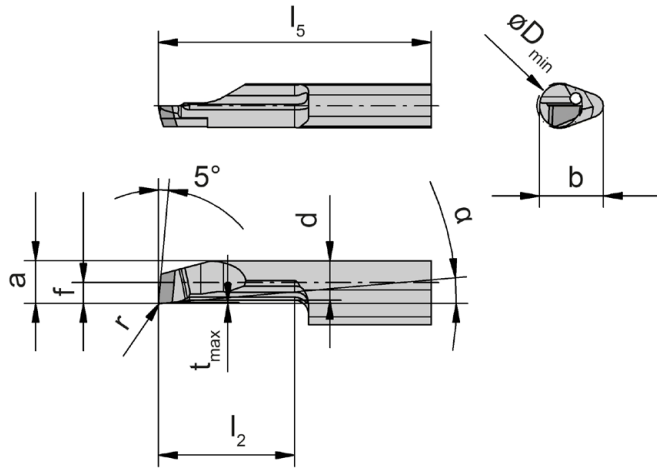
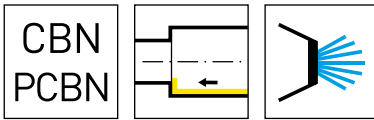

ISO Mat. Code



R = rechts wie gezeichnet
R = right hand version shown

L = links spiegelbildlich
L = left hand version

▲ ab Lager
on stock

HM-Sorten
Carbide grades
Δ 4 Wochen
4 weeks

Bestellnummer Part number	r	f	a	d	b	l ₂	l ₅	t _{max}	D _{min}	α	HIS	CB10	CB35
R105.0523.2.5.B	0,2	2,3	4,7	4,4	7	15	30	0,1	5	5°	105125	▲	
R105.1823.01.1.5.B	0,1	2,3	4,4	4,4	7	10	25	0,2	5	18°	105125	▲	▲
R105.1823.01.2.5.B	0,1	2,3	4,4	4,4	7	15	30	0,2	5	18°	105125	▲	▲
R105.1823.02.1.5.B	0,2	2,3	4,4	4,4	7	10	25	0,2	5	18°	105125	▲	▲
R105.1823.02.2.5.B	0,2	2,3	4,4	4,4	7	15	30	0,2	5	18°	105125	▲	▲
R105.1823.15.3.5.B	0,15	2,3	4,4	4,4	7	20	35	0,3	5	18°	105125	▲	▲
R105.0533.2.6.B	0,2	3,3	5,7	5,3	7	15	30	0,15	6	5°	105125	▲	
R105.1833.01.2.6.B	0,1	3,3	5,7	5,3	7	15	30	0,2	6	18°	105125	▲	▲
R105.1833.02.2.6.B	0,2	3,3	5,7	5,3	7	15	30	0,3	6	18°	105125	▲	▲
R105.0533.3.6.B	0,2	3,3	5,7	5,3	7	20	35	0,15	6	5°	105125	▲	
R105.0540.2.7.B	0,2	4	6,4	6	7	15	30	0,15	6,8	5°	105125	▲	
R105.1840.02.2.7.B	0,2	4	6,4	6	7	15	30	0,3	6,8	18°	105125	▲	▲
R105.1840.02.3.7.B	0,2	4	6,4	6	7	20	35	0,3	6,8	18°	105125	▲	▲
R105.1840.15.4.7.B	0,15	4	6,4	6	7	25	40	0,3	6,8	18°	105125	▲	▲
L105.1823.01.1.5.B	0,1	2,3	4,4	4,4	7	10	25	0,2	5	18°	105125	Δ	Δ
L105.1823.01.2.5.B	0,1	2,3	4,4	4,4	7	15	30	0,2	5	18°	105125	Δ	Δ
L105.1823.02.1.5.B	0,2	2,3	4,4	4,4	7	10	25	0,2	5	18°	105125	Δ	Δ
L105.1823.02.2.5.B	0,2	2,3	4,4	4,4	7	15	30	0,2	5	18°	105125	Δ	Δ
L105.1823.15.3.5.B	0,15	2,3	4,4	4,4	7	20	35	0,3	5	18°	105125	Δ	Δ
L105.1833.01.2.6.B	0,1	3,3	5,7	5,3	7	15	30	0,2	6	18°	105125	Δ	Δ
L105.1833.02.2.6.B	0,2	3,3	5,7	5,3	7	15	30	0,3	6	18°	105125	Δ	Δ
L105.0533.3.6.B	0,2	3,3	5,7	5,3	7	20	35	0,15	6	5°	105125	▲	
L105.1840.02.2.7.B	0,2	4	6,4	6	7	15	30	0,3	6,8	18°	105125	Δ	Δ
L105.1840.02.3.7.B	0,2	4	6,4	6	7	20	35	0,3	6,8	18°	105125	Δ	Δ
L105.1840.15.4.7.B	0,15	4	6,4	6	7	25	40	0,3	6,8	18°	105125	Δ	Δ

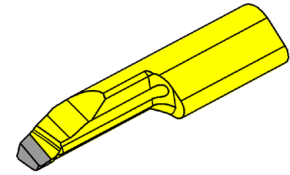
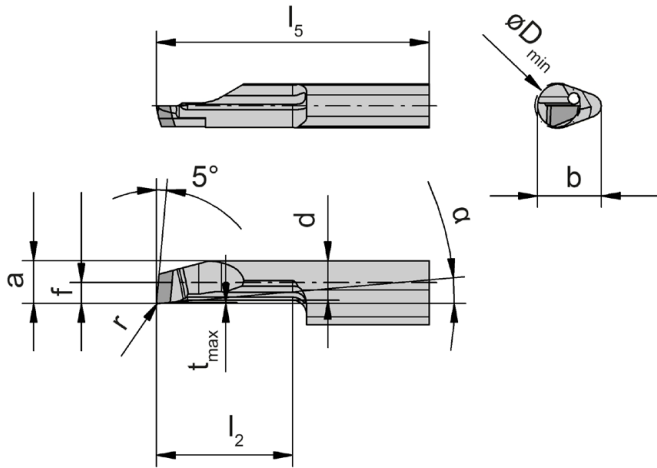
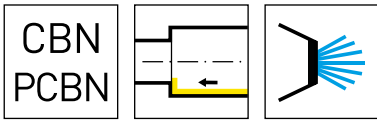

ISO Mat. Code



R = rechts wie gezeichnet
R = right hand version shown

L = links spiegelbildlich
L = left hand version

▲ ab Lager
on stock

HM-Sorten
Carbide grades
Δ 4 Wochen
4 weeks

Bestellnummer Part number	r	f	a	d	b	l ₂	l ₅	t _{max}	D _{min}	α	HIS	CH1G
R105.1813.00.1.2.BA	0,05	1,3	1,7	1,4	7	5	25	0,2	2	18°	105125	▲
R105.1813.01.1.2.BA	0,1	1,3	1,7	1,4	7	5	25	0,2	2	18°	105125	▲
R105.1813.01.0.3.BA	0,1	1,3	2,7	2,4	7	7	25	0,2	3	18°	105125	▲
R105.1813.01.1.3.BA	0,1	1,3	2,7	2,4	7	12	30	0,2	3	18°	105125	▲
R105.1813.02.0.3.BA	0,2	1,3	2,7	2,4	7	7	25	0,2	3	18°	105125	▲
R105.1813.02.1.3.BA	0,2	1,3	2,7	2,4	7	12	30	0,2	3	18°	105125	▲
R105.1815.01.1.4.BA	0,1	1,5	3,7	3,4	7	10	25	0,2	4	18°	105125	▲
R105.1815.01.2.4.BA	0,1	1,5	3,7	3,4	7	15	30	0,2	4	18°	105125	▲
R105.1815.02.1.4.BA	0,2	1,5	3,7	3,4	7	10	25	0,2	4	18°	105125	▲
R105.1815.02.2.4.BA	0,2	1,5	3,7	3,4	7	15	30	0,2	4	18°	105125	▲
L105.1813.00.1.2.BA	0,05	1,3	1,7	1,4	7	5	25	0,2	2	18°	105125	Δ
L105.1813.01.1.2.BA	0,1	1,3	1,7	1,4	7	5	25	0,2	2	18°	105125	Δ
L105.1813.01.0.3.BA	0,1	1,3	2,7	2,4	7	7	25	0,2	3	18°	105125	Δ
L105.1813.01.1.3.BA	0,1	1,3	2,7	2,4	7	12	30	0,2	3	18°	105125	Δ
L105.1813.02.0.3.BA	0,2	1,3	2,7	2,4	7	7	25	0,2	3	18°	105125	Δ
L105.1813.02.1.3.BA	0,2	1,3	2,7	2,4	7	12	30	0,2	3	18°	105125	Δ
L105.1815.01.1.4.BA	0,1	1,5	3,7	3,4	7	10	25	0,2	4	18°	105125	Δ
L105.1815.01.2.4.BA	0,1	1,5	3,7	3,4	7	15	30	0,2	4	18°	105125	Δ
L105.1815.02.1.4.BA	0,2	1,5	3,7	3,4	7	10	25	0,2	4	18°	105125	Δ
L105.1815.02.2.4.BA	0,2	1,5	3,7	3,4	7	15	30	0,2	4	18°	105125	Δ

B

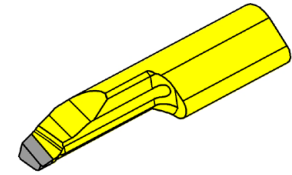
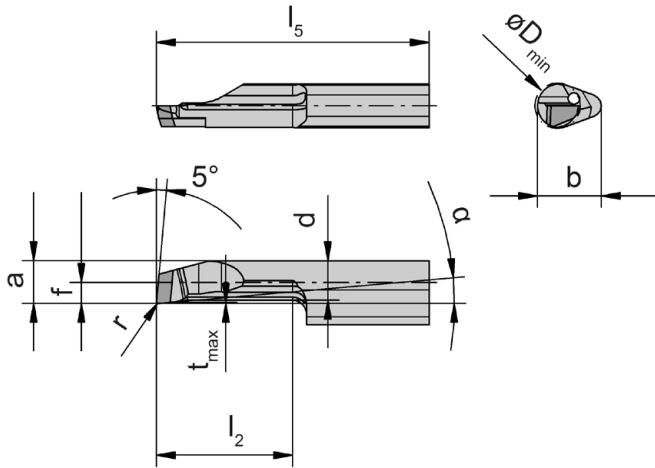
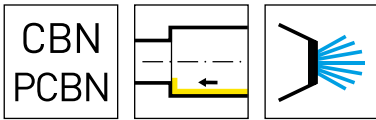

ISO Mat. Code



R = rechts wie gezeichnet
R = right hand version shown

L = links spiegelbildlich
L = left hand version

▲ ab Lager
on stock

HM-Sorten
Carbide grades
Δ 4 Wochen
4 weeks

Bestellnummer Part number	r	f	a	d	b	l ₂	l ₅	t _{max}	D _{min}	α	HIS	CH1G
R105.1823.01.1.5.BA	0,1	2,3	4,4	4,4	7	10	25	0,2	5	18°	105125	▲
R105.1823.01.2.5.BA	0,1	2,3	4,4	4,4	7	15	30	0,2	5	18°	105125	▲
R105.1823.02.1.5.BA	0,2	2,3	4,4	4,4	7	10	25	0,2	5	18°	105125	▲
R105.1823.02.2.5.BA	0,2	2,3	4,4	4,4	7	15	30	0,2	5	18°	105125	▲
R105.1823.15.3.5.BA	0,15	2,3	4,4	4,4	7	20	35	0,3	5	18°	105125	▲
R105.1833.01.2.6.BA	0,1	3,3	5,7	5,3	7	15	30	0,3	6	18°	105125	▲
R105.1840.02.2.7.BA	0,2	4	6,4	6	7	15	30	0,2	6,8	18°	105125	▲
R105.1840.02.3.7.BA	0,2	4	6,4	6	7	20	35	0,3	6,8	18°	105125	▲
R105.1840.15.4.7.BA	0,15	4	6,4	6	7	25	40	0,3	6,8	18°	105125	▲
L105.1823.01.1.5.BA	0,1	2,3	4,4	4,4	7	10	25	0,2	5	18°	105125	Δ
L105.1823.01.2.5.BA	0,1	2,3	4,4	4,4	7	15	30	0,2	5	18°	105125	Δ
L105.1823.02.1.5.BA	0,2	2,3	4,4	4,4	7	10	25	0,2	5	18°	105125	Δ
L105.1823.02.2.5.BA	0,2	2,3	4,4	4,4	7	15	30	0,2	5	18°	105125	Δ
L105.1823.15.3.5.BA	0,15	2,3	4,4	4,4	7	20	35	0,3	5	18°	105125	Δ
L105.1833.01.2.6.BA	0,1	3,3	5,7	5,3	7	15	30	0,3	6	18°	105125	Δ
L105.1840.02.2.7.BA	0,2	4	6,4	6	7	15	30	0,2	6,8	18°	105125	Δ
L105.1840.02.3.7.BA	0,2	4	6,4	6	7	20	35	0,3	6,8	18°	105125	Δ
L105.1840.15.4.7.BA	0,15	4	6,4	6	7	25	40	0,3	6,8	18°	105125	Δ

Mini

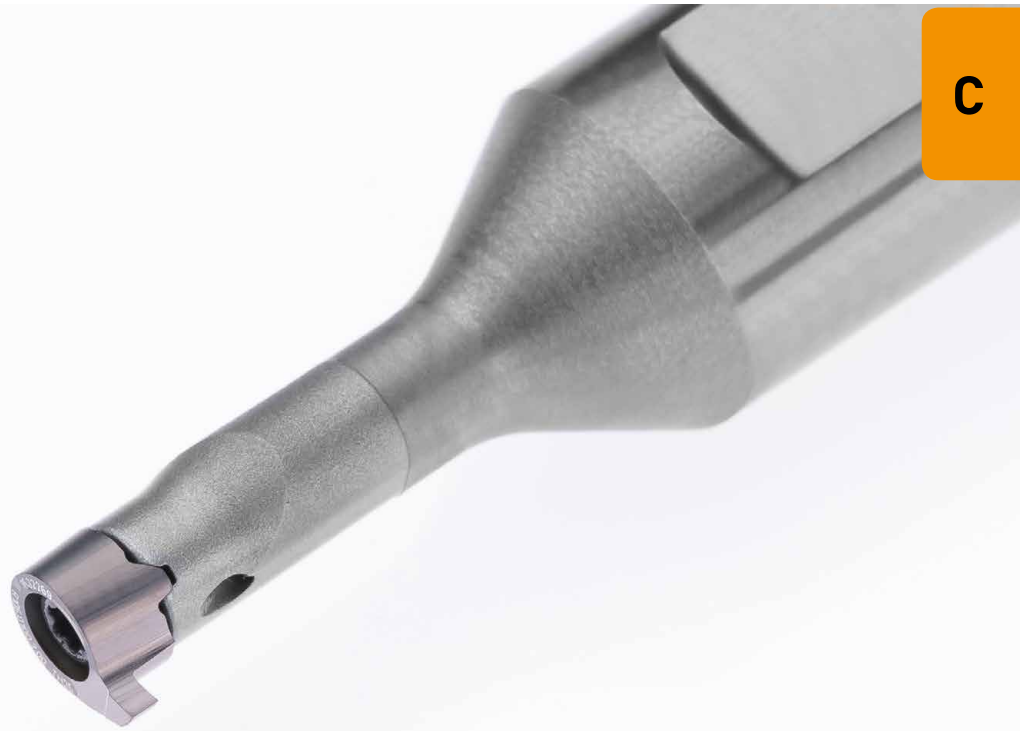

**Klemmhalter und
Schneidplatten**

**Toolholder and
Inserts**

Geometrien und
Vorschübe
Geometries and feed rates

Seite/Page
191

C

Klemmhalter
Toolholder
B106/B107/B108/B111
B114/WFB.114/BA114/
HC114

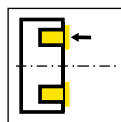
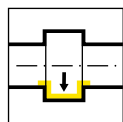

Seite/Page
192, 196, 202,
223-224, 244-
246

Seite/Page
247-248

Schneidplatte
Insert
106/107/108/S108
111/S111/114/S114/DSA

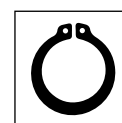
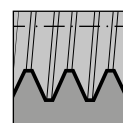
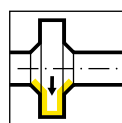
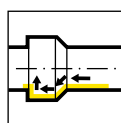
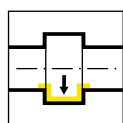

Seite/Page
193, 197-198,
205, 227, 251,
253

Seite/Page
194, 199, 211,
215, 232, 235,
258, 262-267

Seite/Page
195, 200, 216,
236, 264

Seite/Page
201, 218-222,
238-243, 265-
269

Seite/Page
203-204, 225-
226, 249-250

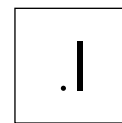
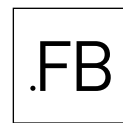
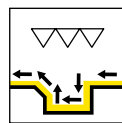
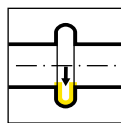
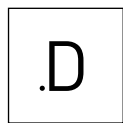

Seite/Page
206, 228, 252,
254

Seite/Page
207, 229, 255

Seite/Page
208, 230, 256

Seite/Page
209, 231, 257

Seite/Page
210

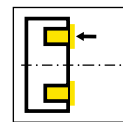
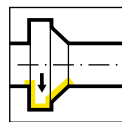
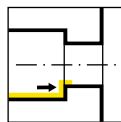
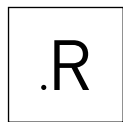

Seite/Page
212, 233, 259

Seite/Page
213, 234, 260

Seite/Page
217, 237, 263

Seite/Page
270-274

Geometrien und Vorschübe - Mini

Geometries and feed rates - Mini



Geometrie Geometry	Werkstoff Material	Vorschubbereich f [mm/U] Feed rate f [mm/rev]	Bearbeitung Machining						
	<table border="1"> <tr> <td>P</td> <td>M</td> <td>K</td> </tr> <tr> <td>N</td> <td>S</td> <td>H</td> </tr> </table>	P	M	K	N	S	H	<p>↓ f = 0,03-0,08</p> <p>↔ ap = 0,2-1,5*</p>	
P	M	K							
N	S	H							
	<table border="1"> <tr> <td>P</td> <td>M</td> <td>K</td> </tr> <tr> <td>N</td> <td>S</td> <td>H</td> </tr> </table>	P	M	K	N	S	H	<p>↓ f = 0,015-0,05</p> <p>↔ ap = 0,03-0,07*</p>	
P	M	K							
N	S	H							
	<table border="1"> <tr> <td>P</td> <td>M</td> <td>K</td> </tr> <tr> <td>N</td> <td>S</td> <td>H</td> </tr> </table>	P	M	K	N	S	H	<p>← f = 0,05-0,15</p> <p>ap = 0,05-0,35</p>	
P	M	K							
N	S	H							
	<table border="1"> <tr> <td>P</td> <td>M</td> <td>K</td> </tr> <tr> <td>N</td> <td>S</td> <td>H</td> </tr> </table>	P	M	K	N	S	H	<p>← f = 0,05-0,15</p> <p>ap = 0,2-1,75*</p>	
P	M	K							
N	S	H							

*Systemabhängig / System dependent

Vorschubbereich f [mm/U]
Feed rate f [mm/rev]

f = 0,01-0,05

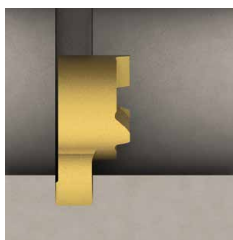

Einstechen
Grooving

f = 0,03-0,1
ap = 0,1-0,5 mm

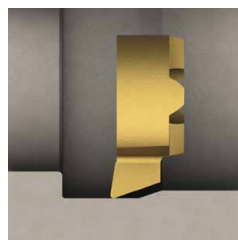

Längsdrehen
Side Turning

f = 0,01-0,08



Axialeinstechen
Face Grooving

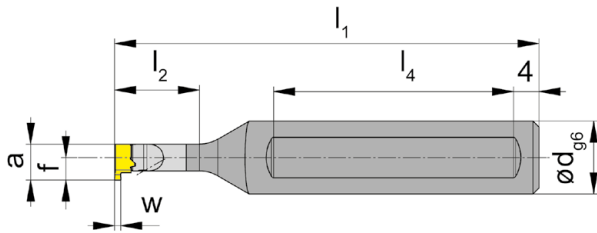
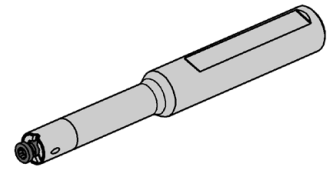
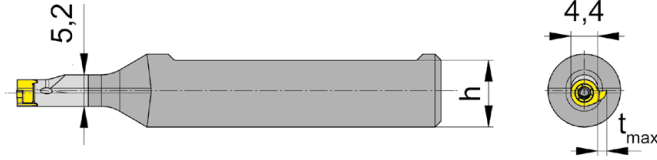
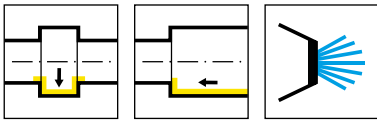

R = rechts wie gezeichnet
R = right hand version shown

L = links spiegelbildlich
L = left hand version

Bestellnummer Part number	d	l ₁	l ₂	h	l ₄	HWS
RB106.0012.01	12	70	14	11	40	304044R
RB106.0012.02	12	80	20	11	40	304044R
RB106.0012.03	12	90	26	11	45	304044R
LB106.0012.01	12	70	14	11	40	304044L
LB106.0012.02	12	80	20	11	40	304044L
LB106.0012.03	12	90	26	11	45	304044L

w, a, t_{max} und f siehe Schneidplatten
w, a, t_{max} and f see inserts

Ersatzteile
Spare Parts

Klemmhalter Toolholder	Spannschraube Clamping Screw	TORX PLUS®-Schlüssel TORX PLUS® Wrench
R/LB106...	1.8.4T6EP	T6PL

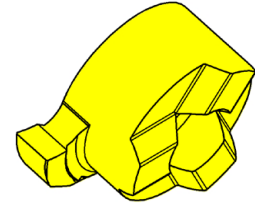
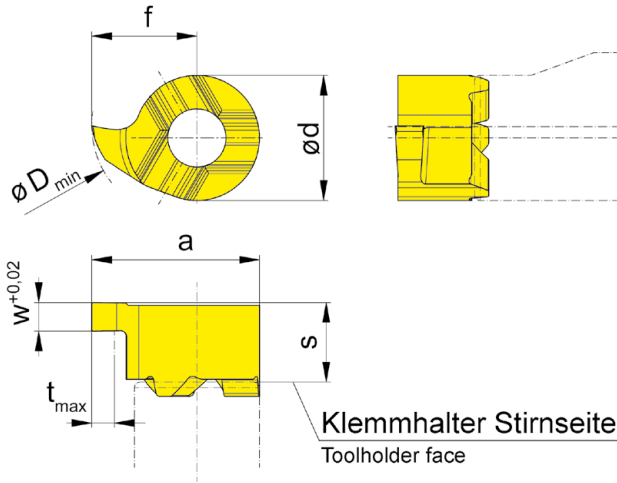
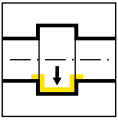

R = rechts wie gezeichnet
R = right hand version shown

L = links spiegelbildlich
L = left hand version

▲ ab Lager
on stock

HM-Sorten
Carbide grades
Δ 4 Wochen
4 weeks

Bestellnummer Part number	w	s	f	a	d	t _{max}	D _{min}	HIS	EG55	TH35
R106.0070.2.00	0,74	2,8	3,7	5,9	4,4	0,8	6,5	304044R	▲	▲
R106.0100.2.00	1	2,8	3,7	5,9	4,4	0,8	6,5	304044R	Δ	▲
R106.0150.2.00	1,5	2,8	3,7	5,9	4,4	0,8	6,5	304044R	Δ	▲
L106.0070.2.00	0,74	2,8	3,7	5,9	4,4	0,8	6,5	304044L	Δ	
L106.0100.2.00	1	2,8	3,7	5,9	4,4	0,8	6,5	304044L	Δ	
L106.0150.2.00	1,5	2,8	3,7	5,9	4,4	0,8	6,5	304044L	Δ	Δ
									P	● ●
									M	○ ●
									K	○ ●
									N	- ●
									S	- ●
									H	- -



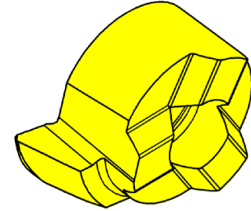
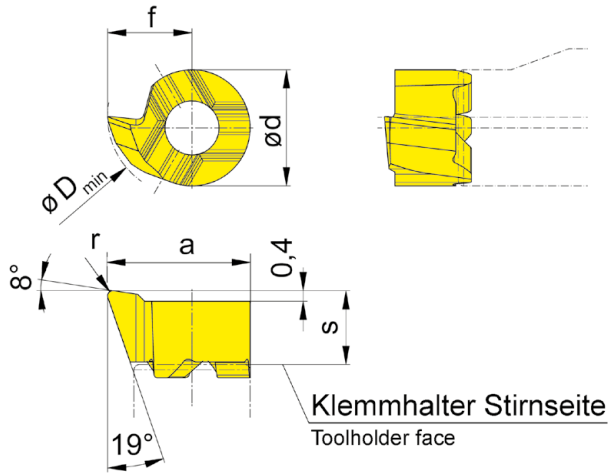
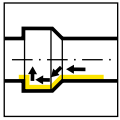

R = rechts wie gezeichnet
R = right hand version shown

L = links spiegelbildlich
L = left hand version

▲ ab Lager
on stock

HM-Sorten
Carbide grades
Δ 4 Wochen
4 weeks

Bestellnummer Part number	s	f	a	r	d	D _{min}	HIS	EG55	TH35
R106.1831.1.005	2,8	3,2	5,4	0,05	4,4	6	304044R	▲	▲
R106.1831.1.02	2,8	3,2	5,4	0,2	4,4	6	304044R	▲	▲
R106.1831.1.04	2,8	3,2	5,4	0,4	4,4	6	304044R	▲	▲
L106.1831.1.005	2,8	3,2	5,4	0,05	4,4	6	304044L	Δ	Δ
L106.1831.1.02	2,8	3,2	5,4	0,2	4,4	6	304044L	Δ	▲
L106.1831.1.04	2,8	3,2	5,4	0,4	4,4	6	304044L		▲
								P	● ●
								M	○ ●
								K	○ ●
								N	- ●
								S	- ●
								H	- -

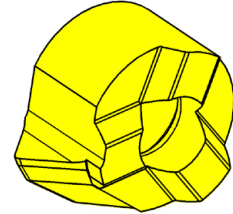
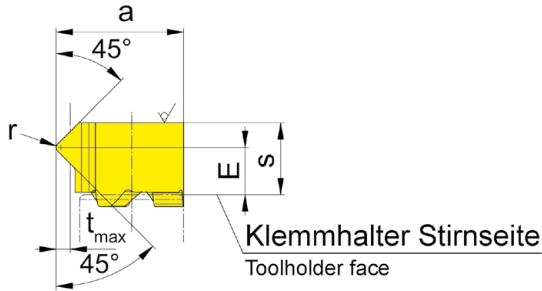
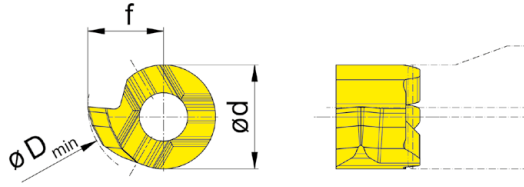
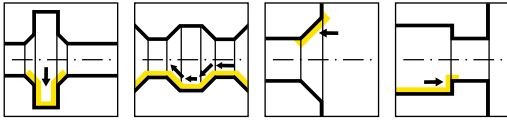

R = rechts wie gezeichnet
R = right hand version shown

L = links spiegelbildlich
L = left hand version

▲ ab Lager
on stock

HM-Sorten
Carbide grades
Δ 4 Wochen
4 weeks

Bestellnummer Part number	E	s	f	a	r	d	t _{max}	D _{min}	HIS	EG55	TH35
R106.4545.1.02	2	3,05	3,2	5,4	0,2	4,4	0,6	6	304044R	▲	▲
L106.4545.1.02	2	3,05	3,2	5,4	0,2	4,4	0,6	6	304044L	Δ	
										P ● ●	
										M ○ ●	
										K ○ ●	
										N - ●	
										S - ●	
										H - -	

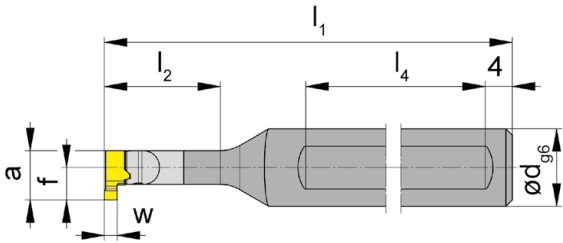
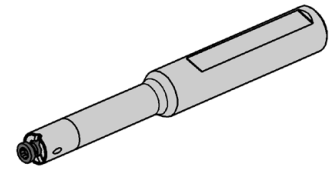
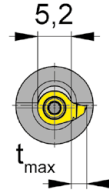
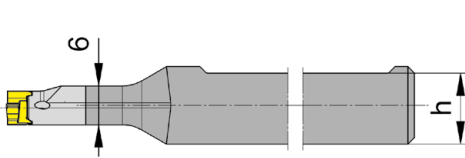
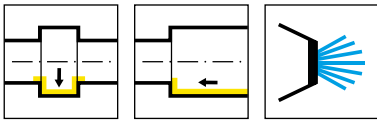

R = rechts wie gezeichnet
R = right hand version shown

L = links spiegelbildlich
L = left hand version

Bestellnummer Part number	d	l ₁	l ₂	h	l ₄	HWS
RB107.0012.01	12	80	18	11	45	107052R
RB107.0012.02	12	90	26	11	45	107052R
RB107.0012.03	12	100	36	11	45	107052R
LB107.0012.01	12	80	18	11	45	107052L
LB107.0012.02	12	90	26	11	45	107052L
LB107.0012.03	12	100	36	11	45	107052L

w, a, tmax und f siehe Schneidplatten
w, a, tmax and f see inserts

Ersatzteile
Spare Parts

Klemmhalter Toolholder	Spannschraube Clamping Screw	TORX PLUS®-Schlüssel TORX PLUS® Wrench
R/LB107...	2.2.5T7EP	T7PL

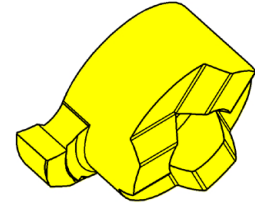
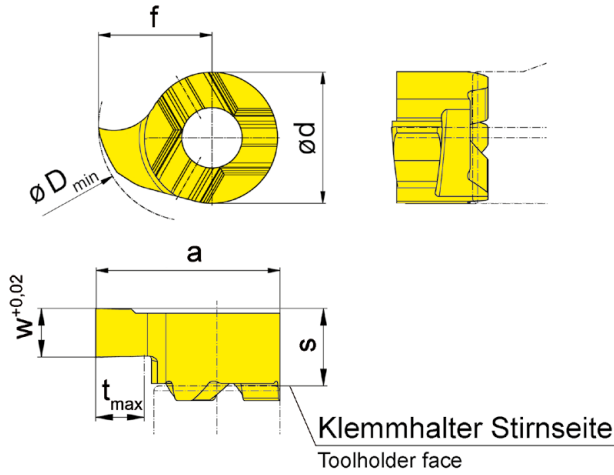
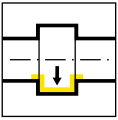

R = rechts wie gezeichnet
R = right hand version shown

L = links spiegelbildlich
L = left hand version

▲ ab Lager
on stock

HM-Sorten
Carbide grades
Δ 4 Wochen
4 weeks

Bestellnummer Part number	w	s	f	a	d	t _{max}	D _{min}	HIS	EG55	TH35
R107.0100.1.00	1	3,3	4	6,6	5,2	1	7	107052R	▲	▲
R107.0150.1.00	1,5	3,3	4	6,6	5,2	1	7	107052R	▲	▲
L107.0100.1.00	1	3,3	4	6,6	5,2	1	7	107052L	Δ	Δ
L107.0150.1.00	1,5	3,3	4	6,6	5,2	1	7	107052L	Δ	▲
									P ● ●	
									M ○ ●	
									K ○ ●	
									N - ●	
									S - ●	
									H - -	



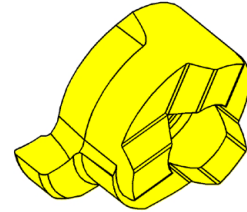
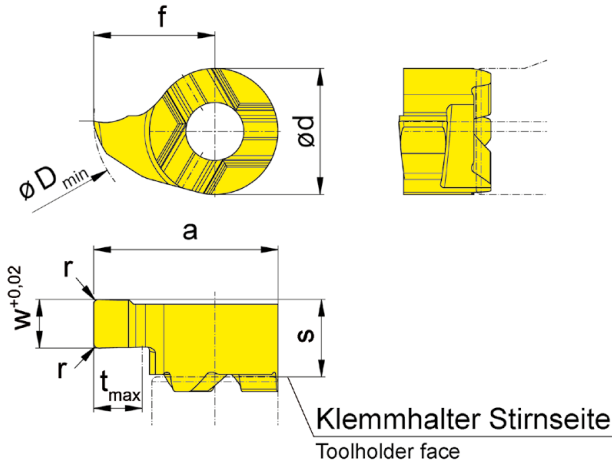
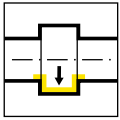

R = rechts wie gezeichnet
R = right hand version shown

L = links spiegelbildlich
L = left hand version

▲ ab Lager
on stock

HM-Sorten
Carbide grades
Δ 4 Wochen
4 weeks

Bestellnummer Part number	w	s	f	a	r	d	t _{max}	D _{min}	HIS	EG55	TH35
R107.0100.2.00	1	3,3	5	7,6	-	5,2	2	8	107052R	▲	▲
R107.0150.2.01	1,5	3,3	5	7,6	0,1	5,2	2	8	107052R	▲	▲
R107.0200.2.02	2	3,3	5	7,6	0,2	5,2	2	8	107052R	▲	▲
L107.0100.2.00	1	3,3	5	7,6	-	5,2	2	8	107052L	Δ	Δ
L107.0150.2.01	1,5	3,3	5	7,6	0,1	5,2	2	8	107052L	Δ	▲
L107.0200.2.02	2	3,3	5	7,6	0,2	5,2	2	8	107052L	Δ	▲
										P	●
										M	○
										K	○
										N	-
										S	-
										H	-

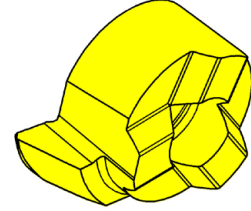
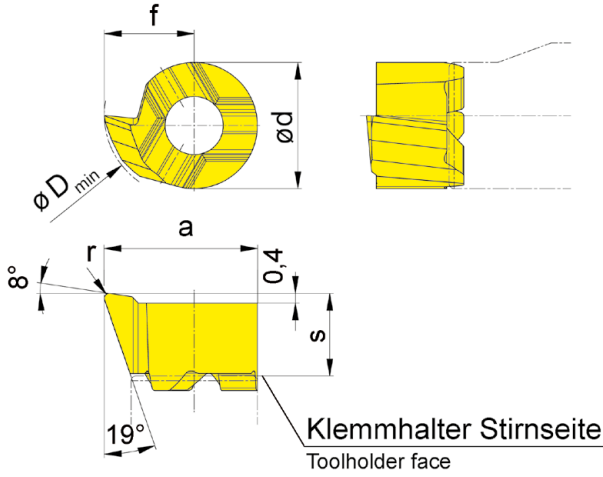
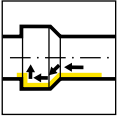

R = rechts wie gezeichnet
R = right hand version shown

L = links spiegelbildlich
L = left hand version

▲ ab Lager
on stock

HM-Sorten
Carbide grades
Δ 4 Wochen
4 weeks

Bestellnummer Part number	s	f	a	r	d	D _{min}	HIS	EG55	TH35
R107.1837.02	3,3	3,7	6,3	0,2	5,2	6,8	107052R	▲	▲
R107.1837.04	3,3	3,7	6,3	0,4	5,2	6,8	107052R	▲	▲
L107.1837.02	3,3	3,7	6,3	0,2	5,2	6,8	107052L	▲	▲
L107.1837.04	3,3	3,7	6,3	0,4	5,2	6,8	107052L	▲	▲
								P ● ●	
								M ○ ●	
								K ○ ●	
								N - ●	
								S - ●	
								H - -	



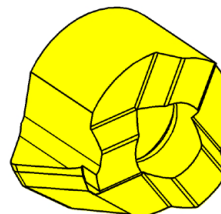
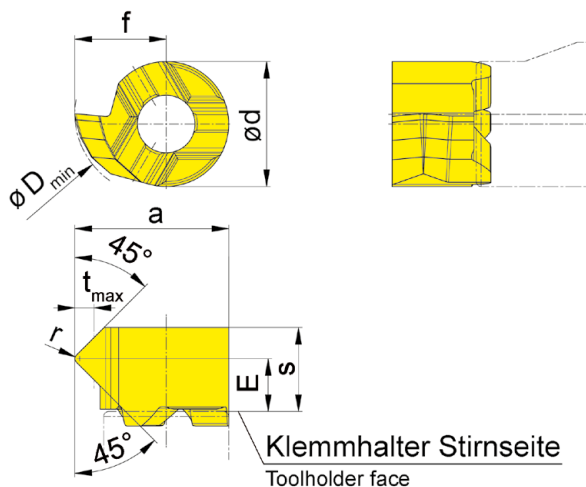
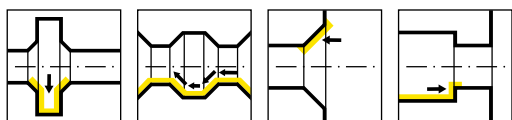

R = rechts wie gezeichnet
R = right hand version shown

L = links spiegelbildlich
L = left hand version

▲ ab Lager
on stock

HM-Sorten
Carbide grades
Δ 4 Wochen
4 weeks

Bestellnummer Part number	E	s	f	a	r	d	t _{max}	D _{min}	HIS	EG55	TH35
R107.4545.1.02	2,2	3,5	3,8	6,4	0,2	5,2	0,8	6,8	107052R	▲	▲
L107.4545.1.02	2,2	3,5	3,8	6,4	0,2	5,2	0,8	6,8	107052L	Δ	Δ
										P ● ●	
										M ○ ●	
										K ○ ●	
										N - ●	
										S - ●	
										H - -	

Schneidplatte

Insert

107

$\emptyset \geq 7 \text{ mm}$

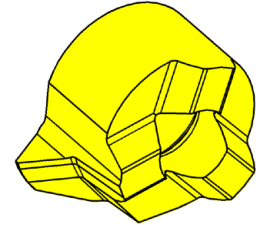
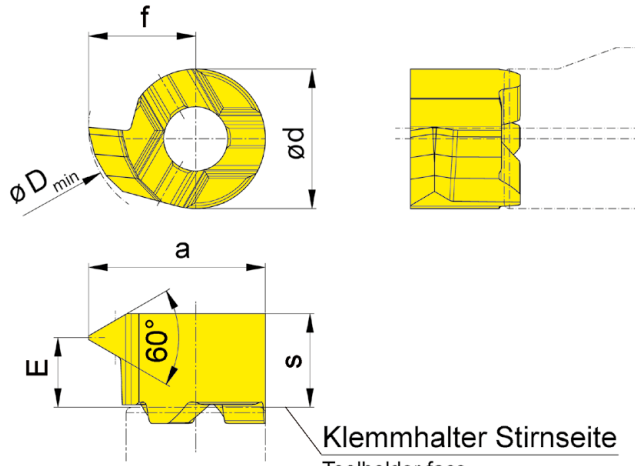

R = rechts wie gezeichnet
R = right hand version shown

L = links spiegelbildlich
L = left hand version

▲ ab Lager
on stock

HM-Sorten
Carbide grades
Δ 4 Wochen
4 weeks

Bestellnummer Part number	P	P _{max}	E	f	a	d	s	D _{min}	HIS	EG55	TH35
R107.0205.1.01	0,5	0,75	3	4	6,6	5,2	3,5	7	107052R	Δ	▲
R107.0510.1.01	1	1,25	2,8	4	6,6	5,2	3,5	7	107052R	▲	▲
R107.0815.1.01	1,5	1,75	2,6	4	6,6	5,2	3,5	7	107052R	▲	▲
L107.0205.1.01	0,5	0,75	3	4	6,6	5,2	3,5	7	107052L	Δ	Δ
L107.0510.1.01	1	1,25	2,8	4	6,6	5,2	3,5	7	107052L	Δ	▲
L107.0815.1.01	1,5	1,75	2,6	4	6,6	5,2	3,5	7	107052L	Δ	Δ
										P	●
										M	○
										K	○
										N	-
										S	-
										H	-





Abbildung = rechtsschneidend
Picture = right hand cutting version

Bestellnummer Part number	d	l_1	l_2	h	l_4	d_1	HWS
B108.0006.01A	6	65	-	-	-	-	306060R • 306060L
B108.0008.00	8	60	12,5	7	35	6	306060R • 306060L
B108.0008.01	8	70	21	7	40	6	306060R • 306060L
B108.0012.00	12	70	12,5	11	40	6	306060R • 306060L
B108.0012.01	12	80	21	11	45	6	306060R • 306060L
B108.0012.02	12	90	30	11	45	6	306060R • 306060L
B108.0012.03	12	100	42	11	45	6	306060R • 306060L

w, a, tmax und f siehe Schneidplatten
w, a, tmax and f see inserts

Ersatzteile
Spare Parts

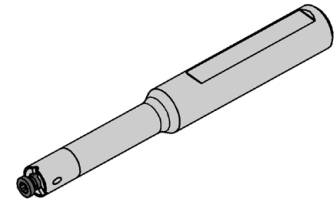
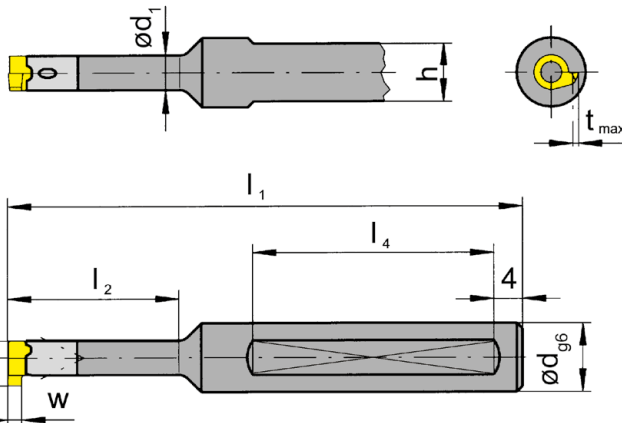
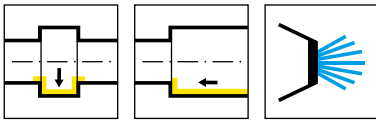
Klemmhalter Toolholder	Spannschraube Clamping Screw	TORX PLUS®-Schlüssel TORX PLUS® Wrench
B108...	2.6.5T8EP	T8PL

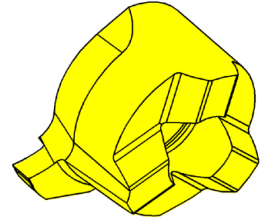
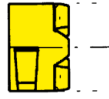
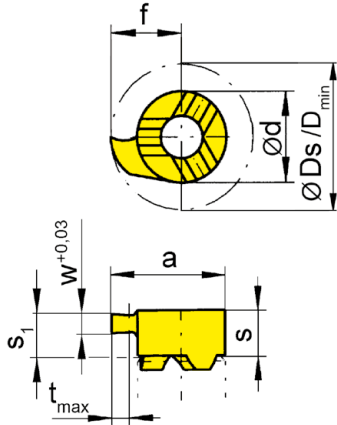
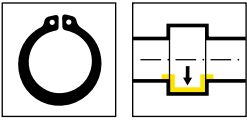

R = rechts wie gezeichnet
R = right hand version shown

L = links spiegelbildlich
L = left hand version

▲ ab Lager
on stock

HM-Sorten
Carbide grades
Δ 4 Wochen
4 weeks

Bestellnummer Part number	w	Nw	f	Ds	d	s	s ₁	a	t _{max}	D _{min}	Z	HIS	EG55	TH35	TN35	
R108.0070.00	0,74	0,7	4,8	9,6	6	3,6	3,2	7,8	1	8	1	306060R	▲	▲	▲	
R108.0080.00	0,84	0,8	4,8	9,6	6	3,6	3,2	7,8	1	8	1	306060R	▲	▲	▲	
R108.0090.00	0,94	0,9	4,8	9,6	6	3,6	3,2	7,8	1	8	1	306060R	▲	▲	▲	
L108.0070.00	0,74	0,7	4,8	9,6	6	3,6	3,2	7,8	1	8	1	306060L	Δ	▲	▲	
L108.0080.00	0,84	0,8	4,8	9,6	6	3,6	3,2	7,8	1	8	1	306060L	Δ	Δ	▲	
L108.0090.00	0,94	0,9	4,8	9,6	6	3,6	3,2	7,8	1	8	1	306060L	Δ	▲	▲	
Zapfenausführung not face cutting, limited depth of cut													P	●	●	●
													M	○	●	●
													K	○	●	●
													N	-	●	●
													S	-	●	●
													H	-	-	-

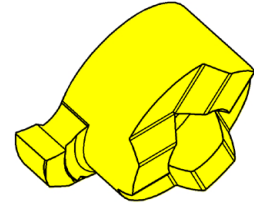
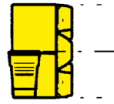
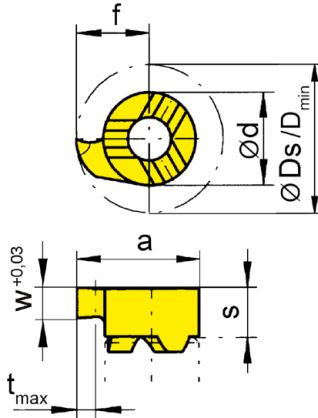
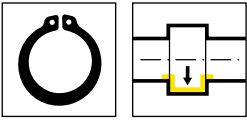

C

R = rechts wie gezeichnet
R = right hand version shown

L = links spiegelbildlich
L = left hand version

▲ ab Lager
on stock

HM-Sorten
Carbide grades
Δ 4 Wochen
4 weeks

Bestellnummer Part number	w	Nw	s	f	Ds	a	d	t _{max}	D _{min}	Z	HIS	MG12	EG55	TH35	TN35
R108.0110.00	1,19	1,1	3,2	4,8	9,6	7,8	6	1	8	1	306060R	▲	▲	▲	▲
R108.0160.00	1,69	1,6	3,2	4,8	9,6	7,8	6	1	8	1	306060R	▲	Δ	▲	▲
R108.0130.00	1,39	1,3	3,2	4,8	9,6	7,8	6	1	8	1	306060R	▲	▲	▲	▲
L108.0110.00	1,19	1,1	3,2	4,8	9,6	7,8	6	1	8	1	306060L	▲	Δ	▲	▲
L108.0160.00	1,69	1,6	3,2	4,8	9,6	7,8	6	1	8	1	306060L		▲	Δ	▲
L108.0130.00	1,39	1,3	3,2	4,8	9,6	7,8	6	1	8	1	306060L			Δ	▲
												P	o	•	•
												M	-	o	•
												K	-	o	•
												N	-	-	•
												S	-	-	•
												H	-	-	-

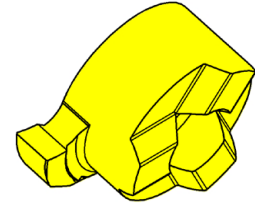
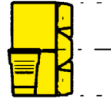
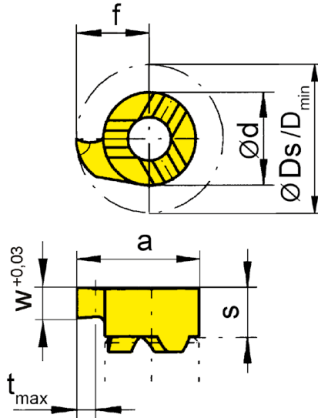
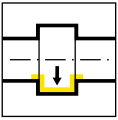

R = rechts wie gezeichnet
R = right hand version shown

L = links spiegelbildlich
L = left hand version

▲ ab Lager
on stock

HM-Sorten
Carbide grades
Δ 4 Wochen
4 weeks

Bestellnummer Part number	w	s	f	Ds	a	d	t _{max}	D _{min}	Z	HIS	MG12	EG55	TH35	TN35
R108.0150.00	1,5	3,2	4,8	9,6	7,8	6	1	8	1	306060R	▲	▲	▲	▲
R108.0200.00	2	3,2	4,8	9,6	7,8	6	1	8	1	306060R	▲	▲	▲	▲
L108.0150.00	1,5	3,2	4,8	9,6	7,8	6	1	8	1	306060L	▲		Δ	▲
L108.0200.00	2	3,2	4,8	9,6	7,8	6	1	8	1	306060L	▲		▲	▲
P	o	•	•	•										
M	-	o	•	•										
K	-	o	•	•										
N	-	-	•	•										
S	-	-	•	•										
H	-	-	-	-										

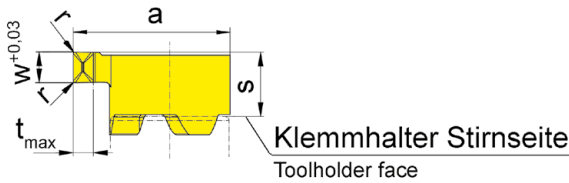
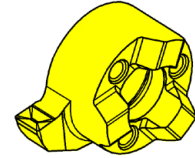
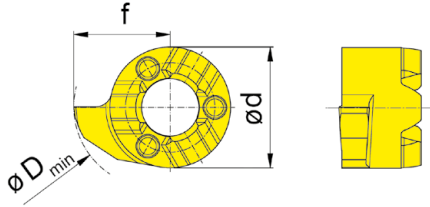
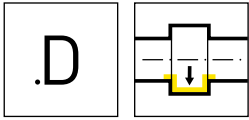

R = rechts wie gezeichnet
R = right hand version shown

L = links spiegelbildlich
L = left hand version

▲ ab Lager
on stock

HM-Sorten
Carbide grades
Δ 4 Wochen
4 weeks

Bestellnummer Part number	w	s	f	a	r	d	t _{max}	D _{min}	HIS	EG55	TH35
RS108.0100.D1	1	3,2	4,8	7,8	0,1	6	1	8	306060R	▲	▲
RS108.0150.D1	1,5	3,2	4,8	7,8	0,1	6	1	8	306060R	▲	▲
RS108.0200.D2	2	3,2	4,8	7,8	0,2	6	1	8	306060R	▲	▲
LS108.0100.D1	1	3,2	4,8	7,8	0,1	6	1	8	306060L	Δ	▲
LS108.0150.D1	1,5	3,2	4,8	7,8	0,1	6	1	8	306060L	Δ	Δ
LS108.0200.D2	2	3,2	4,8	7,8	0,2	6	1	8	306060L	Δ	▲
										P	●
										M	○
										K	○
										N	-
										S	-
										H	-

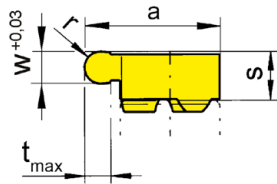
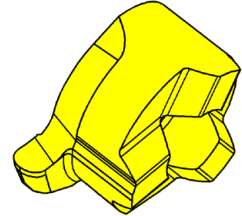
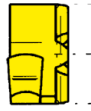
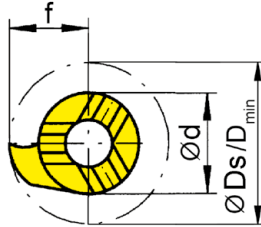
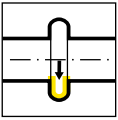

R = rechts wie gezeichnet
R = right hand version shown

L = links spiegelbildlich
L = left hand version

▲ ab Lager
on stock

HM-Sorten
Carbide grades
Δ 4 Wochen
4 weeks

Bestellnummer Part number	w	s	f	Ds	a	r	d	t _{max}	D _{min}	Z	HIS	MG12	EG55	TH35	TI25	TN35
R108.0004.08	0,8	3,2	4,8	9,6	7,8	0,4	6	1	8	1	306060R	▲	▲	▲		▲
R108.0006.12	1,2	3,2	4,8	9,6	7,8	0,6	6	1	8	1	306060R	▲	▲	▲		▲
R108.0009.18	1,8	3,2	4,8	9,6	7,8	0,9	6	1	8	1	306060R	▲	▲	▲	▲	▲
L108.0004.08	0,8	3,2	4,8	9,6	7,8	0,4	6	1	8	1	306060L	Δ	▲	▲		▲
L108.0006.12	1,2	3,2	4,8	9,6	7,8	0,6	6	1	8	1	306060L	▲	▲	▲		▲
L108.0009.18	1,8	3,2	4,8	9,6	7,8	0,9	6	1	8	1	306060L	Δ		▲	Δ	▲
P	o	•	•	•	•	•	•	•	•	•						
M	-	o	•	•	•	•	•	•	•	•						
K	-	o	•	•	•	•	•	•	•	•						
N	-	-	•	•	•	•	•	•	•	•						
S	-	-	•	•	•	•	•	•	•	•						
H	-	-	-	-	-	-	-	-	-	-						



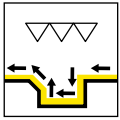

C

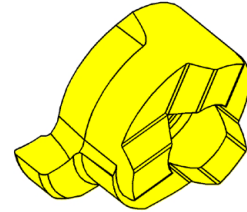
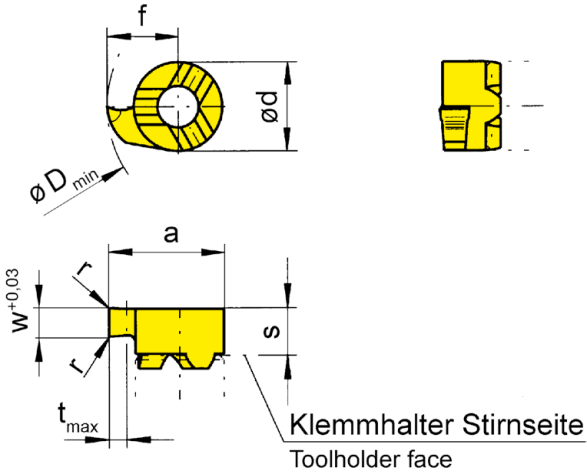

R = rechts wie gezeichnet
R = right hand version shown

L = links spiegelbildlich
L = left hand version

▲ ab Lager
on stock

HM-Sorten
Carbide grades
Δ 4 Wochen
4 weeks

Bestellnummer Part number	w	s	f	a	r	d	t _{max}	D _{min}	HIS	MG12	EG55	TH35	TI25	TN35
R108.0150.02	1,5	3,2	4,8	7,8	0,2	6	1	8	306060R	▲	▲	▲	▲	▲
L108.0150.02	1,5	3,2	4,8	7,8	0,2	6	1	8	306060L	▲	▲	▲	Δ	▲
P	o	•	•	•	•	•	•	•						
M	-	o	•	•	•	•	•	•						
K	-	o	•	•	•	•	•	•						
N	-	-	•	•	•	•	•	•						
S	-	-	•	•	•	•	•	•						
H	-	-	-	-	-	-	-	-						

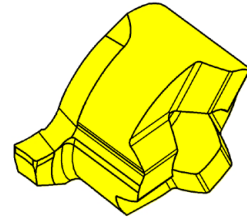
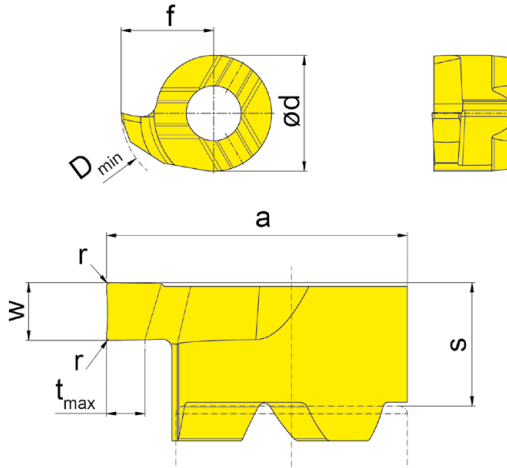
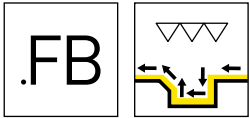

R = rechts wie gezeichnet
R = right hand version shown

L = links spiegelbildlich
L = left hand version

▲ ab Lager
on stock

HM-Sorten
Carbide grades
Δ 4 Wochen
4 weeks

Bestellnummer Part number	w	s	f	a	r	d	t _{max}	D _{min}	HIS	EG35
R108.FB10.01	1	3,2	4,8	7,8	0,1	6	1	8	306060R	▲
R108.FB15.01	1,5	3,2	4,8	7,8	0,1	6	1	8	306060R	▲
L108.FB10.01	1	3,2	4,8	7,8	0,1	6	1	8	306060L	▲
L108.FB15.01	1,5	3,2	4,8	7,8	0,1	6	1	8	306060L	▲

P	●
M	●
K	○
N	-
S	-
H	-

Berechnung der kleinstmöglichen Nutbreite w_x
Calculation of the smallest possible width of groove w_x

Beispiel R108.FB10.01
Example

$w_x = 2 \times \text{Schneidbreite } w - 2 \times \text{Eckenradius Schneidplatte } R$

$w_x = 2 \times \text{Width of insert } w - 2 \times \text{Corner radius insert } R$

$w_x = 2 \times 1 \text{ mm} - 2 \times 0,1 \text{ mm}$

$w_x = 1,8 \text{ mm}$

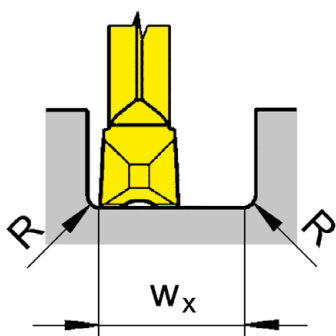

Bearbeitungsablauf
Processing flow

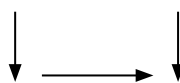

Schneidplatte Insert

S108 $\emptyset \geq 7,8 \text{ mm}$

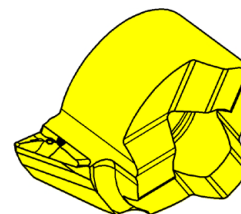
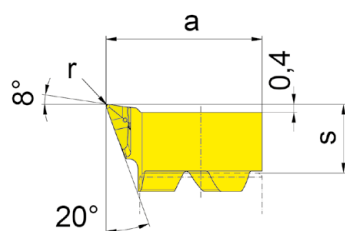
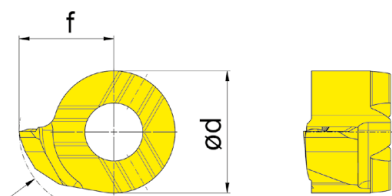
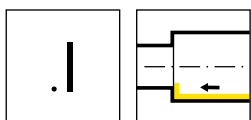

C

R = rechts wie gezeichnet
R = right hand version shown

▲ ab Lager
on stock

HM-Sorten
Carbide grades
Δ 4 Wochen
4 weeks

Bestellnummer Part number	s	f	a	r	d	D _{min}	HIS	HM-Sorten Carbide grades			
								EG35	EG55	IG35	
RS108.0820.105	3,37	4,65	7,65	0,05	6	7,8	306060R	Δ	-	Δ	
RS108.0820.110	3,38	4,65	7,65	0,1	6	7,8	306060R	▲	-	▲	
RS108.0820.120	3,4	4,65	7,65	0,2	6	7,8	306060R	-	▲	▲	
								P	●	●	-
								M	●	○	●
								K	○	○	-
								N	-	-	-
								S	-	-	●
								H	-	-	-

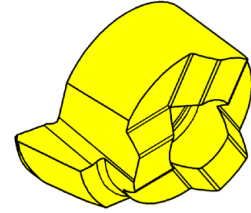
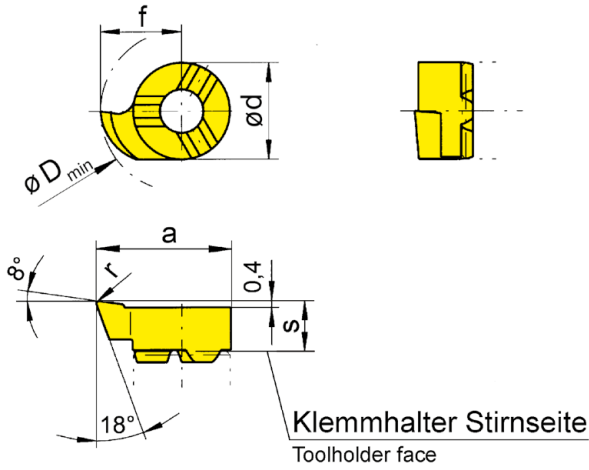
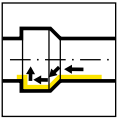

R = rechts wie gezeichnet
R = right hand version shown

L = links spiegelbildlich
L = left hand version

▲ ab Lager
on stock

HM-Sorten
Carbide grades
Δ 4 Wochen
4 weeks

Bestellnummer Part number	s	f	a	r	d	D _{min}	HIS	MG12	EG55	TF45	TH35	TI25	TN35
R108.1846.02	3,4	4,65	7,65	0,2	6	7,8	306060R	▲	▲	Δ	▲	▲	▲
L108.1846.02	3,4	4,65	7,65	0,2	6	7,8	306060L	▲	▲		▲	▲	▲
P	o	•	•	•	•	•							
M	-	o	•	•	•	•							
K	-	o	•	•	•	•							
N	-	-	•	•	•	•							
S	-	-	•	•	•	•							
H	-	-	-	-	-	-							



Schneidplatte Insert

S108

$\varnothing \geq 7,8 \text{ mm}$

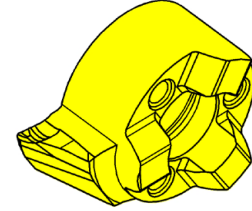
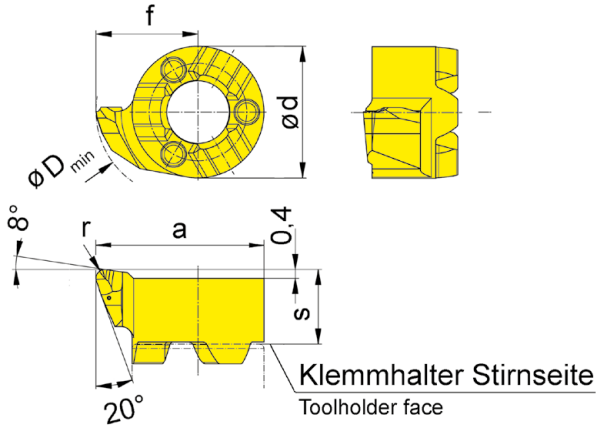
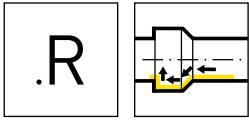

C

R = rechts wie gezeichnet
R = right hand version shown

L = links spiegelbildlich
L = left hand version

▲ ab Lager
on stock

HM-Sorten
Carbide grades
Δ 4 Wochen
4 weeks

Bestellnummer Part number	s	f	a	r	d	D _{min}	HIS	EG55	TH35
RS108.1846.R2	3,4	4,65	7,65	0,2	6	7,8	306060R	▲	▲
RS108.1846.R4	3,4	4,65	7,65	0,4	6	7,8	306060R	▲	▲
LS108.1846.R2	3,4	4,65	7,65	0,2	6	7,8	306060L	▲	▲
LS108.1846.R4	3,4	4,65	7,65	0,4	6	7,8	306060L	▲	▲
								P	●
								M	○
								K	○
								N	-
								S	-
								H	-

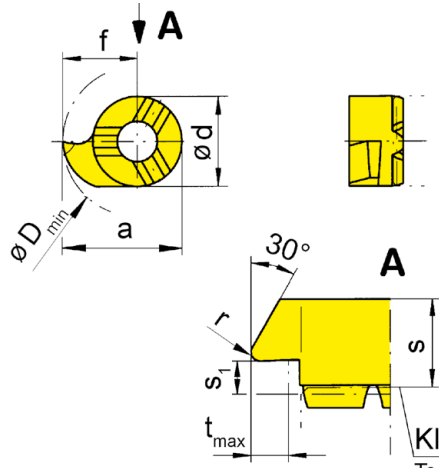
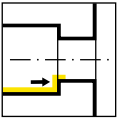

Klemhalter Stirnseite
Toolholder face

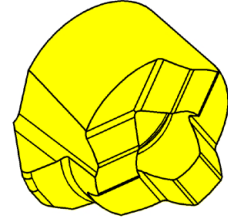

R = rechts wie gezeichnet
R = right hand version shown

L = links spiegelbildlich
L = left hand version

▲ ab Lager
on stock

HM-Sorten
Carbide grades
Δ 4 Wochen
4 weeks

Bestellnummer Part number	s	f	a	r	s ₁	d	t _{max}	D _{min}	HIS	EG55	TH35	TN35
R108.3046.02	3,6	4,65	7,65	0,2	0,8	6	1,3	7,8	306060R	▲	▲	▲
L108.3046.02	3,6	4,65	7,65	0,2	0,8	6	1,3	7,8	306060L	Δ	Δ	▲
P	●	●	●									
M	○	●	●									
K	○	●	●									
N	-	●	●									
S	-	●	●									
H	-	-	-									



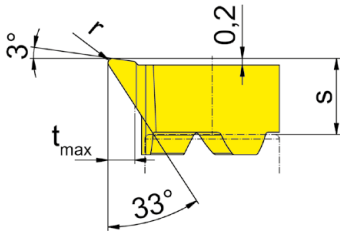
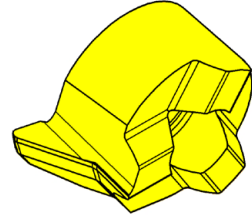
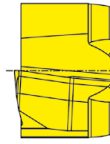
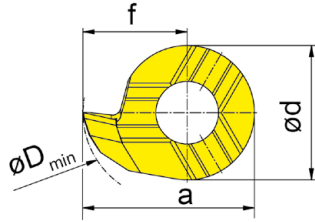
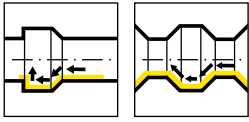

R = rechts wie gezeichnet
R = right hand version shown

L = links spiegelbildlich
L = left hand version

▲ ab Lager
on stock

HM-Sorten
Carbide grades
Δ 4 Wochen
4 weeks

Bestellnummer Part number	s	f	a	r	d	t _{max}	D _{min}	HIS	EG55
R108.3348.01	3,4	4,65	7,65	0,1	6	1,2	7,8	306060R	▲
R108.3348.02	3,4	4,65	7,65	0,2	6	1,2	7,8	306060R	▲
R108.3348.04	3,4	4,65	7,65	0,4	6	1,2	7,8	306060R	▲
L108.3348.01	3,4	4,65	7,65	0,1	6	1,2	7,8	306060L	Δ
L108.3348.02	3,4	4,65	7,65	0,2	6	1,2	7,8	306060L	Δ
L108.3348.04	3,4	4,65	7,65	0,4	6	1,2	7,8	306060L	Δ
									P ●
									M ○
									K ○
									N -
									S -
									H -

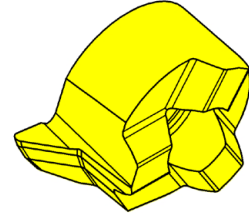
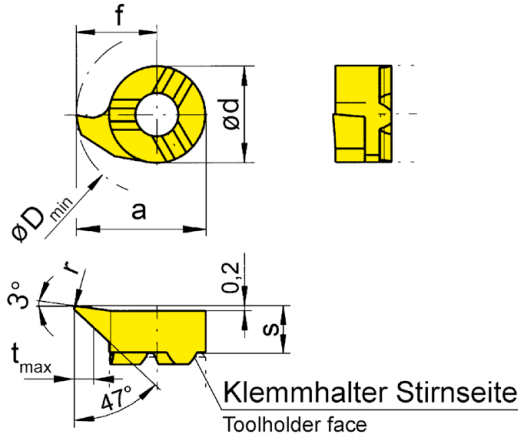
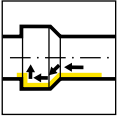

R = rechts wie gezeichnet
R = right hand version shown

L = links spiegelbildlich
L = left hand version

▲ ab Lager
on stock

HM-Sorten
Carbide grades
Δ 4 Wochen
4 weeks

Bestellnummer Part number	s	f	a	r	d	t _{max}	D _{min}	HIS	MG12	EG55	TH35	TN35
R108.4748.01	3,2	4,65	7,65	0,1	6	1,2	7,8	306060R		▲	▲	
R108.4748.02	3,2	4,65	7,65	0,2	6	1,2	7,8	306060R	Δ	▲	▲	▲
R108.4748.04	3,2	4,65	7,65	0,4	6	1,2	7,8	306060R		▲	▲	
L108.4748.01	3,2	4,65	7,65	0,1	6	1,2	7,8	306060L		▲	▲	
L108.4748.02	3,2	4,65	7,65	0,2	6	1,2	7,8	306060L		▲	▲	▲
L108.4748.04	3,2	4,65	7,65	0,4	6	1,2	7,8	306060L		▲	▲	
									P	o	•	•
									M	-	o	•
									K	-	o	•
									N	-	-	•
									S	-	-	•
									H	-	-	-

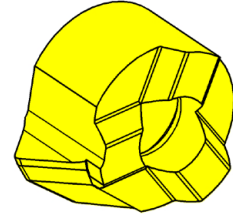
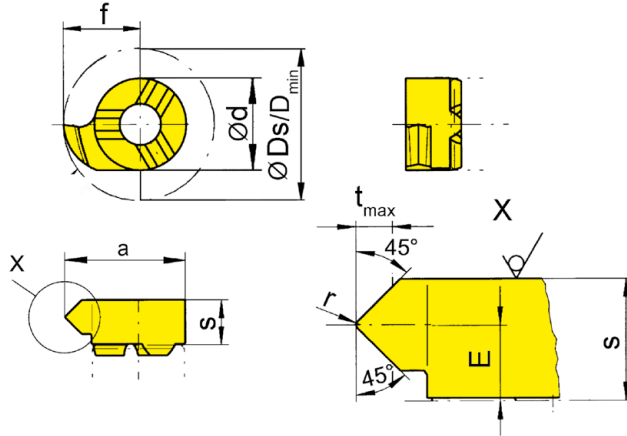
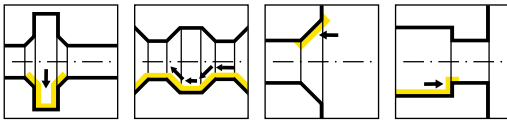

C

R = rechts wie gezeichnet
R = right hand version shown

L = links spiegelbildlich
L = left hand version

HM-Sorten
Carbide grades
▲ ab Lager
on stock
Δ 4 Wochen
4 weeks

Bestellnummer Part number	E	f	Ds	r	d	s	a	D _{min}	α	t _{max}	Z	HIS	EG55	TA45	TI25	TN35
R108.4545.02	1,8	4,65	9,3	0,2	6	3,6	7,65	7,8	45°	1,4	1	306060R	▲	▲	▲	▲
L108.4545.02	1,8	4,65	9,3	0,2	6	3,6	7,65	7,8	45°	1,4	1	306060L	▲	Δ	Δ	▲
P	●	●	●	●	●	●	●	●	●	●	●	●	●	●	●	●
M	○	●	●	●	●	●	●	●	●	●	●	●	●	●	●	●
K	○	●	●	●	●	●	●	●	●	●	●	●	●	●	●	●
N	-	●	●	●	●	●	●	●	●	●	●	●	●	●	●	●
S	-	●	●	●	●	●	●	●	●	●	●	●	●	●	●	●
H	-	-	-	-	-	-	-	-	-	-	-	-	-	-	-	-

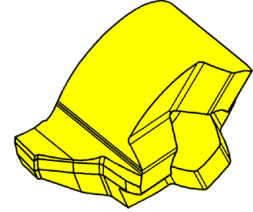
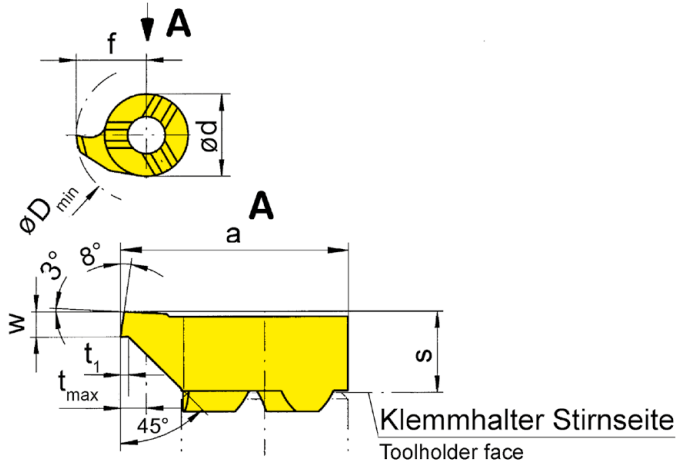
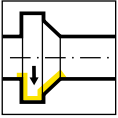

R = rechts wie gezeichnet
R = right hand version shown

L = links spiegelbildlich
L = left hand version

▲ ab Lager
on stock

HM-Sorten
Carbide grades
Δ 4 Wochen
4 weeks

Bestellnummer Part number	w	s	f	a	d	t _{max}	t ₁	D _{min}	HIS	MG12	EG55	TI25	TN35
R108.0810.45	1	3,2	4,8	7,8	6	1,5	0,2	8	306060R	▲	▲	▲	▲
L108.0810.45	1	3,2	4,8	7,8	6	1,5	0,2	8	306060L	Δ	▲	▲	▲
										P	o	•	•
										M	-	o	•
										K	-	o	•
										N	-	-	•
										S	-	-	•
										H	-	-	-

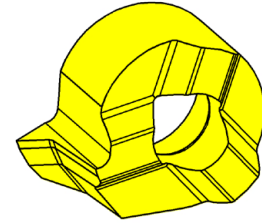
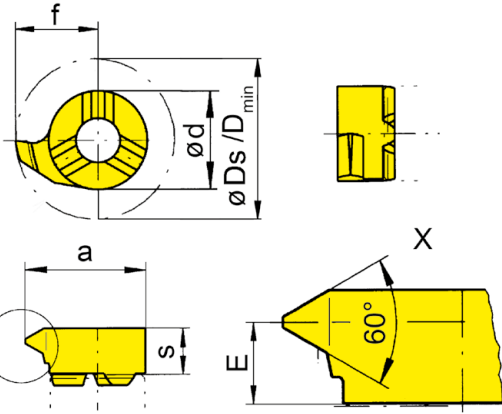

C

R = rechts wie gezeichnet
R = right hand version shown

L = links spiegelbildlich
L = left hand version

▲ ab Lager
on stock

HM-Sorten
Carbide grades
Δ 4 Wochen
4 weeks

Bestellnummer Part number	P	P _{max}	E	f	a	d	s	D _{min}	D _s	HIS	MG12	EG55	TH35	TI25	TN35
R108.0205.01	0,5	0,75	2,8	4,8	7,8	6	3,6	8	9,6	306060R	▲	▲	▲		▲
R108.0510.01	1	1,25	2,8	4,8	7,8	6	3,6	8	9,6	306060R	▲	▲	▲	▲	▲
R108.0815.01	1,5	1,75	2,6	4,8	7,8	6	3,6	8	9,6	306060R	▲	▲	▲		▲
L108.0205.01	0,5	0,75	2,8	4,8	7,8	6	3,6	8	9,6	306060L	Δ	▲	▲		▲
L108.0510.01	1	1,25	2,8	4,8	7,8	6	3,6	8	9,6	306060L	Δ	▲	▲	▲	▲
L108.0815.01	1,5	1,75	2,6	4,8	7,8	6	3,6	8	9,6	306060L	Δ	▲	▲		▲
	P	o	•	•	•	•	•								
	M	-	o	•	•	•	•								
	K	-	o	•	•	•	•								
	N	-	-	•	•	•	•								
	S	-	-	•	•	•	•								
	H	-	-	-	-	-	-								

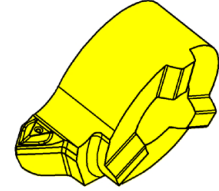
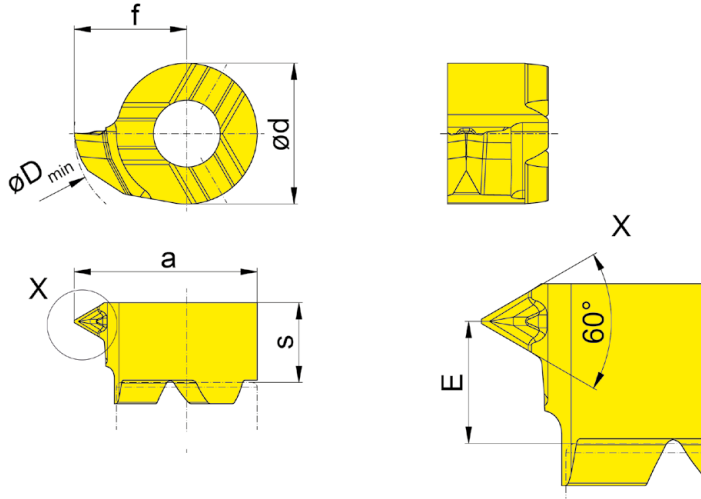
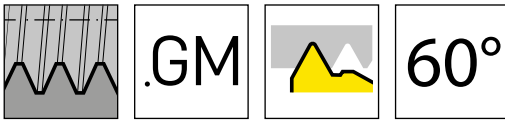

R = rechts wie gezeichnet
R = right hand version shown

▲ ab Lager
on stock

HM-Sorten
Carbide grades
Δ 4 Wochen
4 weeks

Bestellnummer Part number	P	P _{max}	E	f	a	d	s	D _{min}	HIS	EG55
RS108.0205.GM1	0,5	0,75	2,6	4,8	7,8	6	3,4	8	306060R	▲
RS108.0510.GM1	1	1,25	2,6	4,8	7,8	6	3,4	8	306060R	▲
RS108.0815.GM1	1,5	1,5	2,6	4,8	7,8	6	3,4	8	306060R	▲
LS108.0205.GM1	0,5	0,75	2,6	4,8	7,8	6	3,4	8	306060L	▲
LS108.0510.GM1	1	1,25	2,6	4,8	7,8	6	3,4	8	306060L	▲
LS108.0815.GM1	1,5	1,5	2,6	4,8	7,8	6	3,4	8	306060L	▲
										P ●
										M ○
										K ○
										N -
										S -
										H -



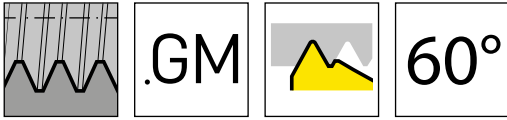

C

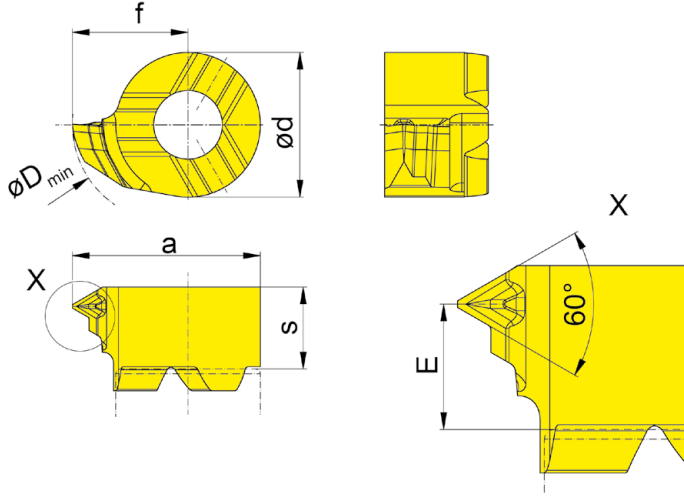

R = rechts wie gezeichnet
R = right hand version shown

L = links spiegelbildlich
L = left hand version

▲ ab Lager
on stock

HM-Sorten
Carbide grades
Δ 4 Wochen
4 weeks

Bestellnummer Part number	P	E	f	a	d	s	D _{min}	HIS	EG55
RS108.0305.GM2	0,5	2,6	4,8	7,8	6	3,4	8	306060R	▲
RS108.0510.GM2	1	2,6	4,8	7,8	6	3,4	8	306060R	▲
RS108.0512.GM2	1,25	2,6	4,8	7,8	6	3,4	8	306060R	▲
RS108.0815.GM2	1,5	2,6	4,8	7,8	6	3,4	8	306060R	▲
LS108.0305.GM2	0,5	2,6	4,8	7,8	6	3,4	8	306060L	▲
LS108.0510.GM2	1	2,6	4,8	7,8	6	3,4	8	306060L	▲
LS108.0512.GM2	1,25	2,6	4,8	7,8	6	3,4	8	306060L	▲
LS108.0815.GM2	1,5	2,6	4,8	7,8	6	3,4	8	306060L	▲
	P	●							
	M	o							
	K	o							
	N	-							
	S	-							
	H	-							

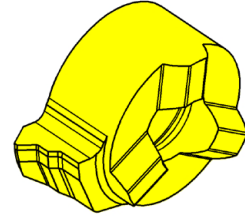
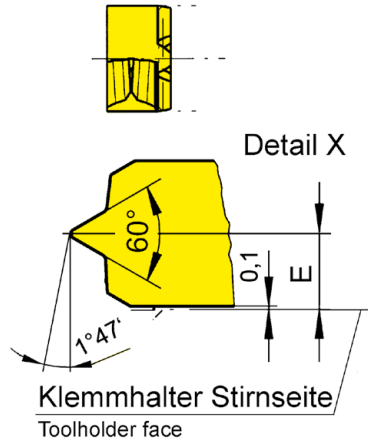
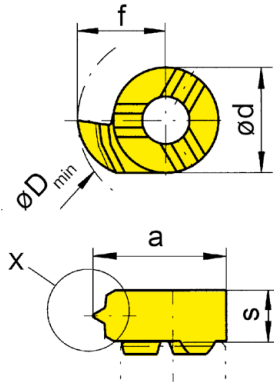

R = rechts wie gezeichnet
R = right hand version shown

▲ ab Lager
on stock

HM-Sorten
Carbide grades
Δ 4 Wochen
4 weeks

Bestellnummer Part number	TPI	E	f	d	s	D_{min}	HIS	EG55	TN35
R108.NP14.02	14	1,9	4,8	6	3,6	8	306060R	▲	▲
R108.NP18.02	18	1,9	4,8	6	3,6	8	306060R	▲	▲
R108.NP27.02	27	1,9	4,8	6	3,6	8	306060R	Δ	▲
								P	● ●
								M	○ ●
								K	○ ●
								N	- ●
								S	- ●
								H	- -



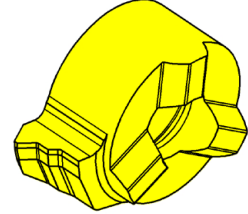
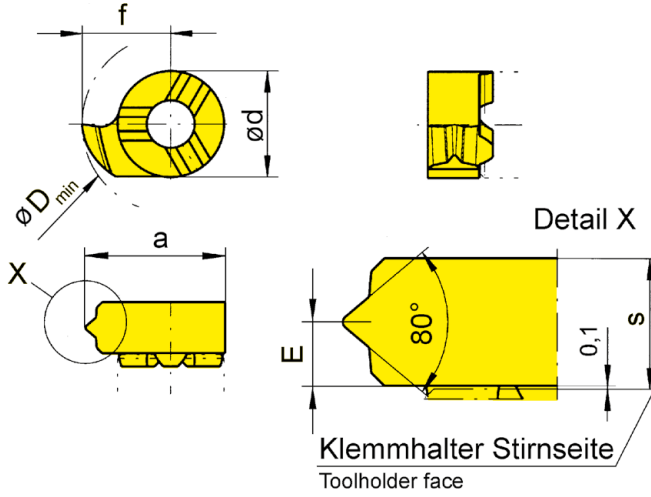

R = rechts wie gezeichnet
R = right hand version shown

▲ ab Lager
on stock

HM-Sorten
Carbide grades
Δ 4 Wochen
4 weeks

Bestellnummer Part number	TPI	E	f	d	s	D_{min}	HIS	EG55	TN35
R108.PG18.02	18	1,9	4,8	6	3,6	8	306060R	▲	▲
R108.PG20.02	20	1,9	4,8	6	3,6	8	306060R	▲	▲
								P ● ●	
								M ○ ●	
								K ○ ●	
								N - ●	
								S - ●	
								H - -	



Abbildung = rechtsschneidend
Picture = right hand cutting version

Bestellnummer Part number	d	l_1	l_2	h	l_4	d_1	HWS
B111.0008.01A	8	80	-	-	-	-	308080R • 308080L
B111.0012.00	12	75	16,5	11	40	8	308080R • 308080L
B111.0012.01	12	95	29	11	50	8	308080R • 308080L
B111.0012.02	12	110	42	11	50	8	308080R • 308080L
B111.0012.03	12	120	56	11	50	8	308080R • 308080L

w, a, tmax und f siehe Schneidplatten
w, a, tmax and f see inserts

Ersatzteile
Spare Parts

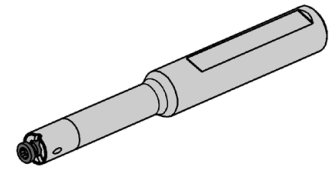
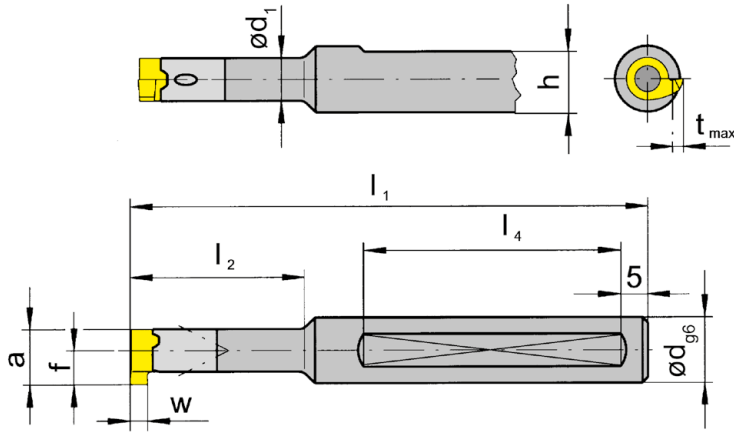
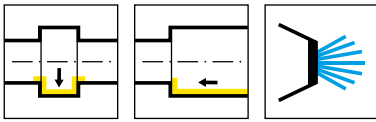
Klemmhalter Toolholder	Spannschraube Clamping Screw	TORX PLUS®-Schlüssel TORX PLUS® Wrench
B111...	3.5.12T10EP	T10PL

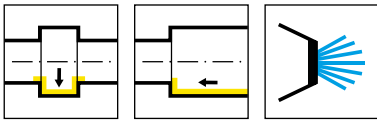

C

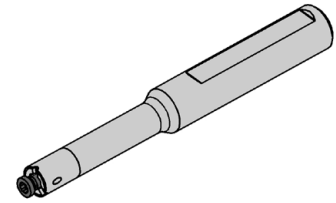
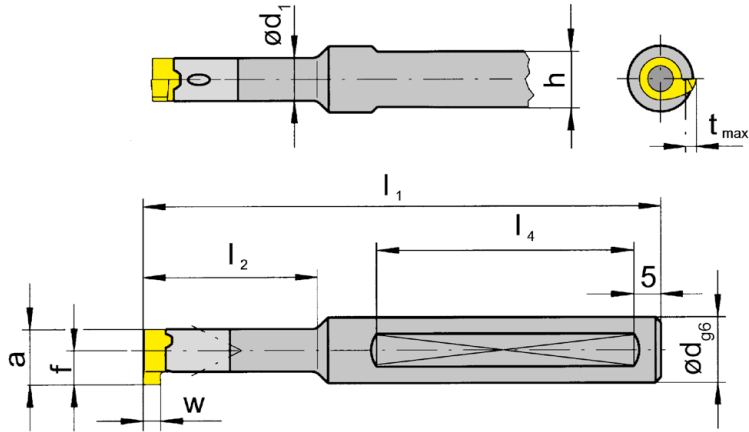

R = rechts wie gezeichnet
R = right hand version shown

Bestellnummer Part number	d	l_1	l_2	h	l_4	d_1	HWS
B111.0012.2.00	12	75	16,5	11	40	8	308080R • 308080L
B111.0012.2.01	12	95	29	11	50	8	308080R • 308080L
B111.0012.2.02	12	110	42	11	50	8	308080R • 308080L
B111.0012.2.03	12	120	56	11	50	8	308080R • 308080L

w, a, tmax und f siehe Schneidplatten
w, a, tmax and f see inserts

Ersatzteile
Spare Parts

Klemmhalter Toolholder	Spannschraube Clamping Screw	TORX PLUS®-Schlüssel TORX PLUS® Wrench
B111...	3.5.12T10EP	T10PL

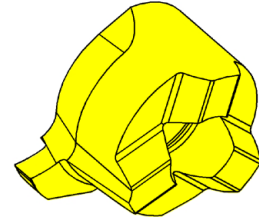
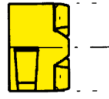
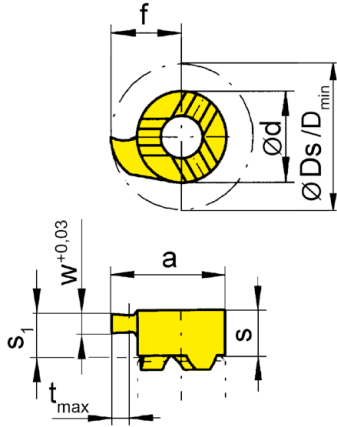
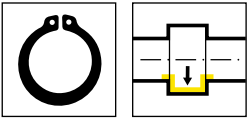

R = rechts wie gezeichnet
R = right hand version shown

L = links spiegelbildlich
L = left hand version

▲ ab Lager
on stock

HM-Sorten
Carbide grades
Δ 4 Wochen
4 weeks

Bestellnummer Part number	w	Nw	f	Ds	d	s	s ₁	a	t _{max}	D _{min}	Z	HIS	MG12	EG55	TH35	TN35
R111.0070.00	0,74	0,7	6,7	13,4	8	4,15	3,95	10,7	1,2	11	1	308080R		▲	▲	▲
R111.0080.00	0,84	0,8	6,7	13,4	8	4,15	3,95	10,7	1,3	11	1	308080R		▲	▲	▲
R111.0090.00	0,94	0,9	6,7	13,4	8	4,15	3,95	10,7	1,5	11	1	308080R	▲	▲	▲	▲
L111.0070.00	0,74	0,7	6,7	13,4	8	4,15	3,95	10,7	1,2	11	1	308080L			Δ	▲
L111.0080.00	0,84	0,8	6,7	13,4	8	4,15	3,95	10,7	1,3	11	1	308080L			Δ	▲
L111.0090.00	0,94	0,9	6,7	13,4	8	4,15	3,95	10,7	1,5	11	1	308080L	▲		▲	▲

Zapfenausführung
not face cutting, limited depth of cut

P	o	•	•	•
M	-	o	•	•
K	-	o	•	•
N	-	-	•	•
S	-	-	•	•
H	-	-	-	-

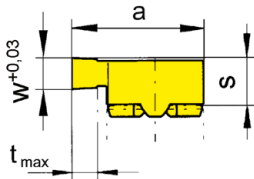
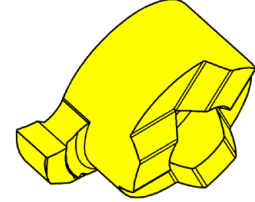
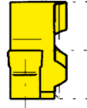
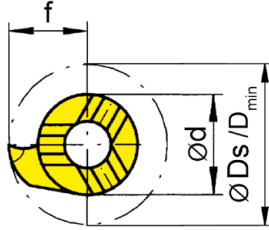
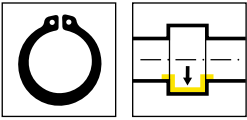

R = rechts wie gezeichnet
R = right hand version shown

L = links spiegelbildlich
L = left hand version

▲ ab Lager
on stock

HM-Sorten
Carbide grades
Δ 4 Wochen
4 weeks

Bestellnummer Part number	w	Nw	s	f	Ds	d	a	t _{max}	D _{min}	Z	HIS	MG12	EG55	TH35	TN35
R111.0110.00	1,19	1,1	3,95	6,7	13,4	8	10,7	2,3	11	1	308080R	▲	▲	▲	▲
R111.0130.00	1,39	1,3	3,95	6,7	13,4	8	10,7	2,3	11	1	308080R	▲	▲	▲	▲
R111.0160.00	1,69	1,6	3,95	6,7	13,4	8	10,7	2,3	11	1	308080R	▲	▲	▲	▲
L111.0110.00	1,19	1,1	3,95	6,7	13,4	8	10,7	2,3	11	1	308080L	▲	▲	▲	▲
L111.0130.00	1,39	1,3	3,95	6,7	13,4	8	10,7	2,3	11	1	308080L	Δ	Δ	▲	▲
L111.0160.00	1,69	1,6	3,95	6,7	13,4	8	10,7	2,3	11	1	308080L	Δ	▲	▲	▲
												P	o	•	•
												M	-	o	•
												K	-	o	•
												N	-	-	•
												S	-	-	•
												H	-	-	-

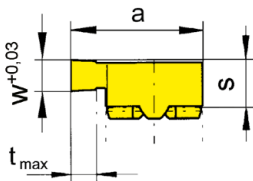
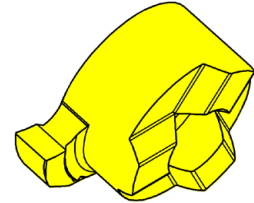
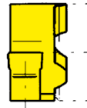
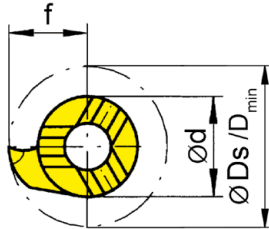
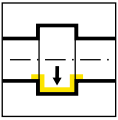

R = rechts wie gezeichnet
R = right hand version shown

L = links spiegelbildlich
L = left hand version

▲ ab Lager
on stock

HM-Sorten
Carbide grades
Δ 4 Wochen
4 weeks

Bestellnummer Part number	w	s	f	Ds	d	a	t _{max}	D _{min}	Z	HIS	MG12	EG55	TH35	TN35
R111.0100.1.00	1	3,95	6,7	13,4	8	10,7	2,3	11	1	308080R	▲	Δ	▲	▲
R111.0150.00	1,5	3,95	6,7	13,4	8	10,7	2,3	11	1	308080R	▲	▲	▲	▲
R111.0200.00	2	3,95	6,7	13,4	8	10,7	2,3	11	1	308080R	▲	▲	▲	▲
R111.0250.00	2,5	3,95	6,7	13,4	8	10,7	2,3	11	1	308080R	▲	▲	▲	▲
R111.0300.00	3	3,95	6,7	13,4	8	10,7	2,3	11	1	308080R	▲	▲	▲	▲
L111.0100.1.00	1	3,95	6,7	13,4	8	10,7	2,3	11	1	308080L	▲	Δ	▲	▲
L111.0150.00	1,5	3,95	6,7	13,4	8	10,7	2,3	11	1	308080L	▲	▲	▲	▲
L111.0200.00	2	3,95	6,7	13,4	8	10,7	2,3	11	1	308080L	▲	▲	▲	▲
L111.0250.00	2,5	3,95	6,7	13,4	8	10,7	2,3	11	1	308080L	▲	▲	▲	▲
L111.0300.00	3	3,95	6,7	13,4	8	10,7	2,3	11	1	308080L	▲	▲	▲	▲
											P	o	•	•
											M	-	o	•
											K	-	o	•
											N	-	-	•
											S	-	-	•
											H	-	-	-



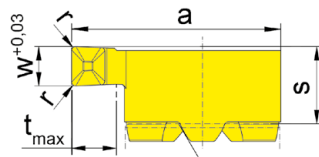
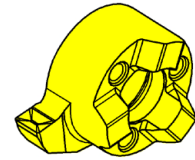
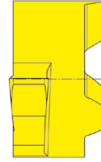
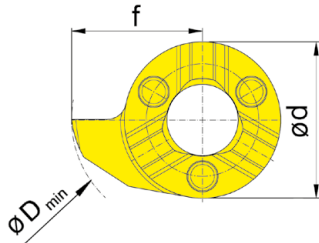
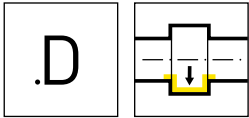

Klemhalter Stirnseite
Toolholder face

R = rechts wie gezeichnet
R = right hand version shown

L = links spiegelbildlich
L = left hand version

▲ ab Lager
on stock

HM-Sorten
Carbide grades
Δ 4 Wochen
4 weeks

Bestellnummer Part number	w	s	f	a	r	d	t _{max}	D _{min}	HIS	EG55	TH35	TN35
RS111.0150.D1	1,5	3,95	6,7	10,7	0,1	8	2,3	11	308080R	▲	▲	
RS111.0200.D2	2	3,95	6,7	10,7	0,2	8	2,3	11	308080R	▲	▲	
RS111.0250.D2	2,5	3,95	6,7	10,7	0,2	8	2,3	11	308080R	▲	▲	Δ
LS111.0150.D1	1,5	3,95	6,7	10,7	0,1	8	2,3	11	308080L	Δ	▲	
LS111.0200.D2	2	3,95	6,7	10,7	0,2	8	2,3	11	308080L	▲	▲	
LS111.0250.D2	2,5	3,95	6,7	10,7	0,2	8	2,3	11	308080L	Δ	▲	
P	●	●	●									
M	○	●	●									
K	○	●	●									
N	-	●	●									
S	-	●	●									
H	-	-	-									

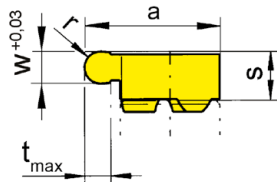
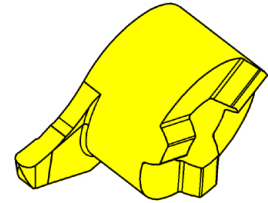
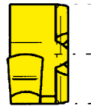
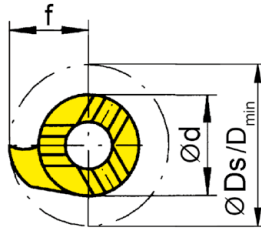
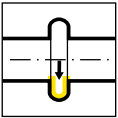

R = rechts wie gezeichnet
R = right hand version shown

L = links spiegelbildlich
L = left hand version

▲ ab Lager
on stock

HM-Sorten
Carbide grades
Δ 4 Wochen
4 weeks

Bestellnummer Part number	w	f	Ds	r	d	s	a	t _{max}	D _{min}	Z	HIS	MG12	EG55	TH35	TN35
R111.0004.08	0,8	6,7	13,4	0,4	8	3,95	10,7	2,3	11	1	308080R	▲	▲	▲	▲
R111.0006.12	1,2	6,7	13,4	0,6	8	3,95	10,7	2,3	11	1	308080R	▲	▲	▲	▲
R111.0009.18	1,8	6,7	13,4	0,9	8	3,95	10,7	2,3	11	1	308080R	▲	▲	▲	▲
R111.0010.20	2	6,7	13,4	1	8	3,95	10,7	2,3	11	1	308080R	▲	▲	▲	▲
R111.0015.30	3	6,7	13,4	1,5	8	3,95	10,7	2,3	11	1	308080R	▲	▲	▲	▲
L111.0004.08	0,8	6,7	13,4	0,4	8	3,95	10,7	2,3	11	1	308080L	▲	▲	▲	▲
L111.0006.12	1,2	6,7	13,4	0,6	8	3,95	10,7	2,3	11	1	308080L	Δ	▲	▲	▲
L111.0009.18	1,8	6,7	13,4	0,9	8	3,95	10,7	2,3	11	1	308080L	Δ	▲	▲	▲
L111.0010.20	2	6,7	13,4	1	8	3,95	10,7	2,3	11	1	308080L	▲	▲	▲	▲
L111.0015.30	3	6,7	13,4	1,5	8	3,95	10,7	2,3	11	1	308080L	Δ	▲	▲	▲
												P	o	•	•
												M	-	o	•
												K	-	o	•
												N	-	-	•
												S	-	-	•
												H	-	-	-



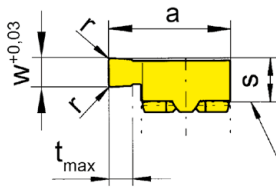
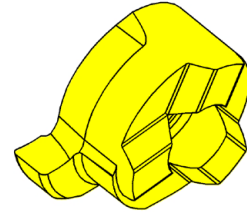
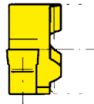
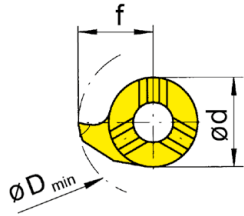
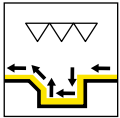

Klemmhalter Stirnseite
Toolholder face

R = rechts wie gezeichnet
R = right hand version shown

L = links spiegelbildlich
L = left hand version

▲ ab Lager
on stock

HM-Sorten
Carbide grades
Δ 4 Wochen
4 weeks

Bestellnummer Part number	w	s	f	a	r	d	t _{max}	D _{min}	HIS	MG12	EG55	TH35	TI25	TN35
R111.0200.02	2	3,95	6,7	10,7	0,2	8	2,3	11	308080R	▲	▲	▲	▲	▲
L111.0200.02	2	3,95	6,7	10,7	0,2	8	2,3	11	308080L	▲	▲	▲	Δ	▲
P	o	•	•	•	•	•	•	•	•	•	•	•	•	•
M	-	o	•	•	•	•	•	•	•	•	•	•	•	•
K	-	o	•	•	•	•	•	•	•	•	•	•	•	•
N	-	-	•	•	•	•	•	•	•	•	•	•	•	•
S	-	-	•	•	•	•	•	•	•	•	•	•	•	•
H	-	-	-	-	-	-	-	-	-	-	-	-	-	-

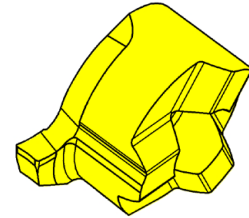
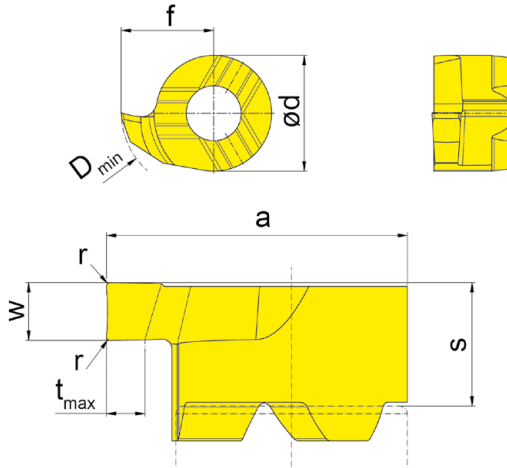
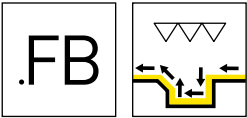

R = rechts wie gezeichnet
R = right hand version shown

L = links spiegelbildlich
L = left hand version

▲ ab Lager
on stock

HM-Sorten
Carbide grades
Δ 4 Wochen
4 weeks

Bestellnummer Part number	w	s	f	a	r	d	t _{max}	D _{min}	HIS	EG35
R111.FB10.01	1	3,95	6,7	10,7	0,1	8	2,3	11	308080R	▲
R111.FB15.01	1,5	3,95	6,7	10,7	0,1	8	2,3	11	308080R	▲
L111.FB10.01	1	3,95	6,7	10,7	0,1	8	2,3	11	308080L	▲
L111.FB15.01	1,5	3,95	6,7	10,7	0,1	8	2,3	11	308080L	▲

P	●
M	●
K	○
N	-
S	-
H	-

Berechnung der kleinstmöglichen Nutbreite w_x
Calculation of the smallest possible width of groove w_x

Beispiel R111.FB10.01
Example

$w_x = 2 \times \text{Schneidbreite } w - 2 \times \text{Eckenradius Schneidplatte } R$

$w_x = 2 \times \text{Width of insert } w - 2 \times \text{Corner radius insert } R$

$w_x = 2 \times 1 \text{ mm} - 2 \times 0,1 \text{ mm}$

$w_x = 1,8 \text{ mm}$

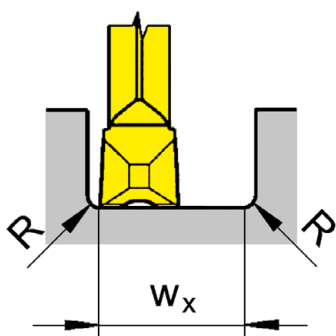

Bearbeitungsablauf
Processing flow

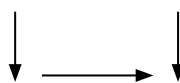

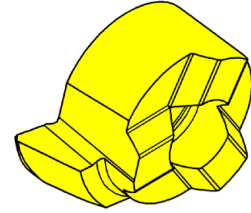
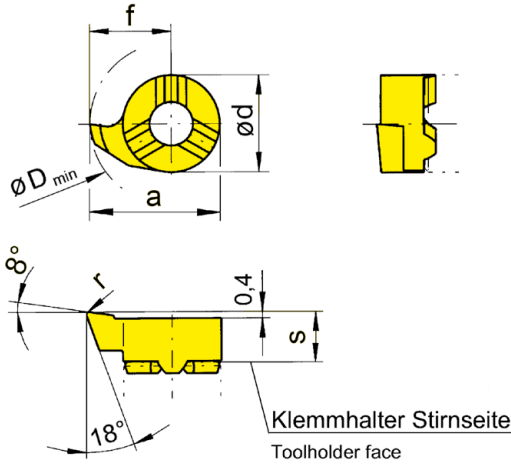
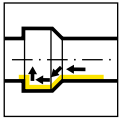

R = rechts wie gezeichnet
R = right hand version shown

L = links spiegelbildlich
L = left hand version

▲ ab Lager
on stock

HM-Sorten
Carbide grades
Δ 4 Wochen
4 weeks

Bestellnummer Part number	s	f	a	r	d	D _{min}	HIS	MG12	EG55	TH35	TI25	TN35
R111.1855.02	3,95	5,5	9,5	0,2	8	9,8	308080R	▲	▲	▲	▲	▲
R111.1867.02	3,95	6,7	10,7	0,2	8	11	308080R	▲	▲	▲	▲	▲
L111.1855.02	3,95	5,5	9,5	0,2	8	9,8	308080L	▲	▲	▲	▲	▲
L111.1867.02	3,95	6,7	10,7	0,2	8	11	308080L	▲	▲	▲	▲	▲
P	o	•	•	•	•							
M	-	o	•	•	•							
K	-	o	•	•	•							
N	-	-	•	•	•							
S	-	-	•	•	•							
H	-	-	-	-	-							

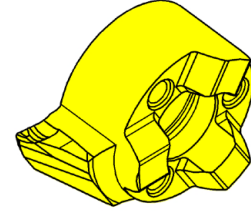
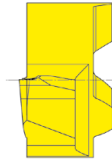
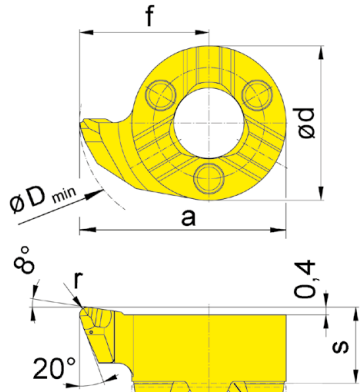
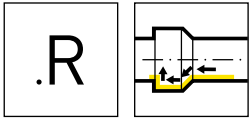

Klemmhalter Stirnseite
Toolholder face

R = rechts wie gezeichnet
R = right hand version shown

L = links spiegelbildlich
L = left hand version

▲ ab Lager
on stock

HM-Sorten
Carbide grades
Δ 4 Wochen
4 weeks

Bestellnummer Part number	s	f	a	r	d	D _{min}	HIS	EG55	TH35
RS111.1867.R2	3,95	6,7	10,7	0,2	8	11	308080R	▲	▲
RS111.1867.R4	3,95	6,7	10,7	0,4	8	11	308080R	▲	▲
LS111.1867.R2	3,95	6,7	10,7	0,2	8	11	308080L	▲	▲
LS111.1867.R4	3,95	6,7	10,7	0,4	8	11	308080L	▲	▲
								P	●
								M	○
								K	○
								N	-
								S	-
								H	-

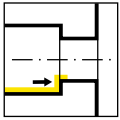

C

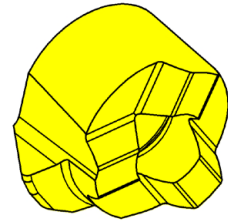
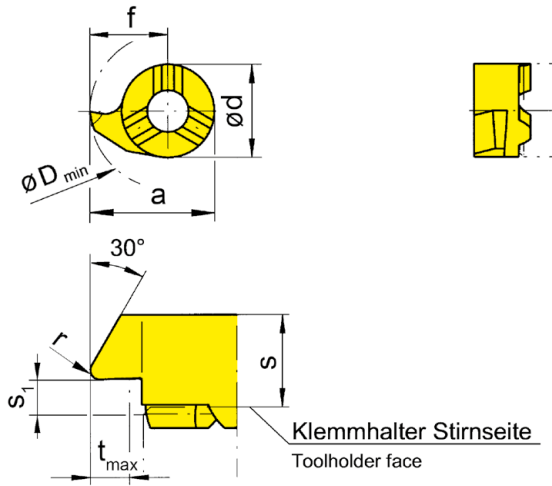

R = rechts wie gezeichnet
R = right hand version shown

L = links spiegelbildlich
L = left hand version

▲ ab Lager
on stock

HM-Sorten
Carbide grades
Δ 4 Wochen
4 weeks

Bestellnummer Part number	s	f	a	r	s ₁	d	t _{max}	D _{min}	HIS	EG55	TH35	TN35
R111.3067.02	4,15	6,7	10,7	0,2	1,4	8	2,3	11	308080R	▲	▲	▲
R111.3067.04	4,15	6,7	10,7	0,4	1,4	8	2,3	11	308080R	Δ	▲	Δ
L111.3067.02	4,15	6,7	10,7	0,2	1,4	8	2,3	11	308080L	▲	▲	▲
L111.3067.04	4,15	6,7	10,7	0,4	1,4	8	2,3	11	308080L	Δ	Δ	▲
P	●	●	●									
M	○	●	●									
K	○	●	●									
N	-	●	●									
S	-	●	●									
H	-	-	-									

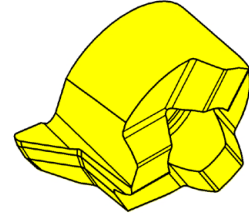
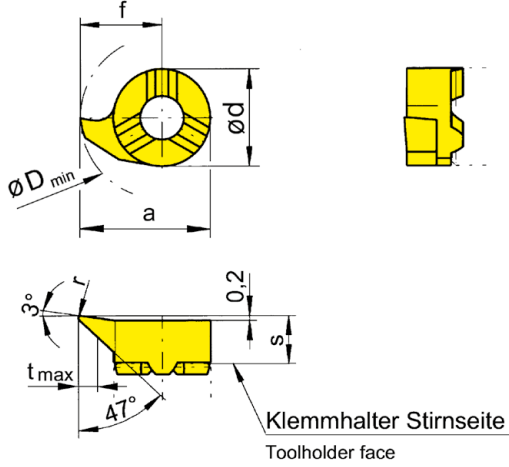
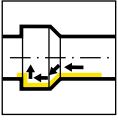

R = rechts wie gezeichnet
R = right hand version shown

L = links spiegelbildlich
L = left hand version

▲ ab Lager
on stock

HM-Sorten
Carbide grades
Δ 4 Wochen
4 weeks

Bestellnummer Part number	s	f	a	r	d	t _{max}	D _{min}	HIS	EG55	TH35	TI25	TN35
R111.4767.02	3,95	6,7	10,7	0,2	8	2,3	11	308080R	▲	▲	▲	▲
R111.4767.04	3,95	6,7	10,7	0,4	8	2,3	11	308080R	▲	▲	▲	▲
L111.4767.02	3,95	6,7	10,7	0,2	8	2,3	11	308080L	▲	▲	▲	▲
L111.4767.04	3,95	6,7	10,7	0,4	8	2,3	11	308080L	▲	▲	Δ	▲
P	●	●	●	●	●	●	●		●	●	●	●
M	○	●	●	●	●	●	●		○	●	●	●
K	○	●	●	●	●	●	●		○	●	●	●
N	-	●	●	●	●	●	●		-	●	●	●
S	-	●	●	●	●	●	●		-	●	●	●
H	-	-	-	-	-	-	-		-	-	-	-



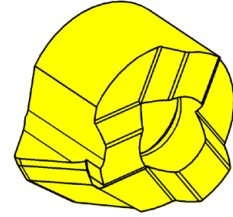
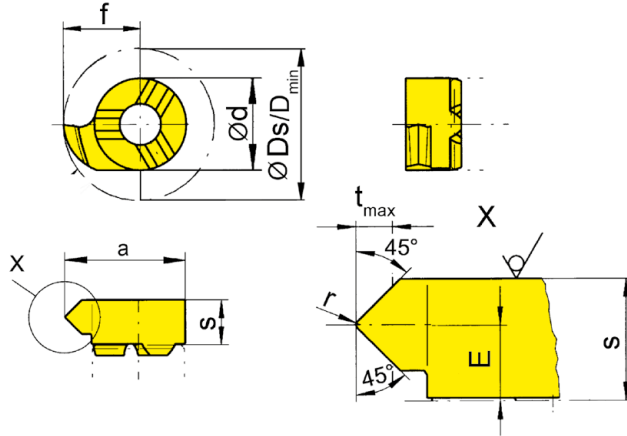
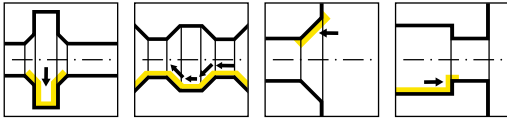

C

R = rechts wie gezeichnet
R = right hand version shown

L = links spiegelbildlich
L = left hand version

▲ ab Lager
on stock

HM-Sorten
Carbide grades
Δ 4 Wochen
4 weeks

Bestellnummer Part number	E	f	Ds	r	d	s	a	t _{max}	D _{min}	Z	HIS	EG55	TN35
R111.4545.02	2,4	6,7	13,4	0,2	8	4,15	10,7	1,5	11	1	308080R	▲	▲
L111.4545.02	2,4	6,7	13,4	0,2	8	4,15	10,7	1,5	11	1	308080L	▲	▲
P	●	●											
M	○	●											
K	○	●											
N	-	●											
S	-	●											
H	-	-											

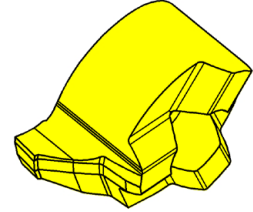
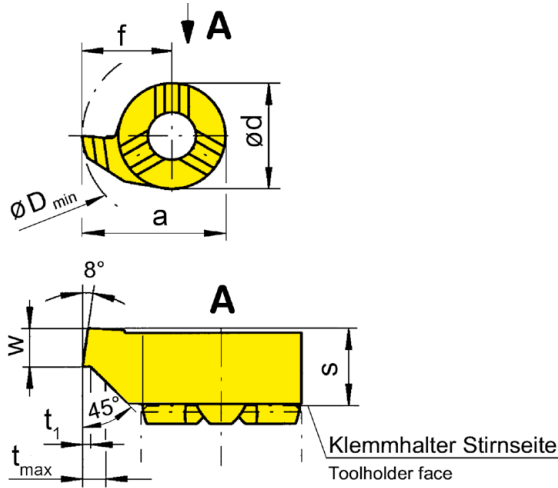
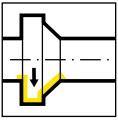

R = rechts wie gezeichnet
R = right hand version shown

L = links spiegelbildlich
L = left hand version

▲ ab Lager
on stock

HM-Sorten
Carbide grades
Δ 4 Wochen
4 weeks

Bestellnummer Part number	w	s	a	f	d	t _{max}	t _{1max}	D _{min}	HIS	MG12	EG55	TI25
R111.0810.45	1	3,95	10,7	6,7	8	1,5	0,2	11	308080R	▲	▲	▲
L111.0810.45	1	3,95	10,7	6,7	8	1,5	0,2	11	308080L	Δ	▲	▲
										P	o	•
										M	-	o
										K	-	o
										N	-	-
										S	-	-
										H	-	-

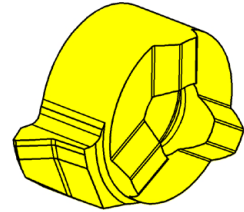
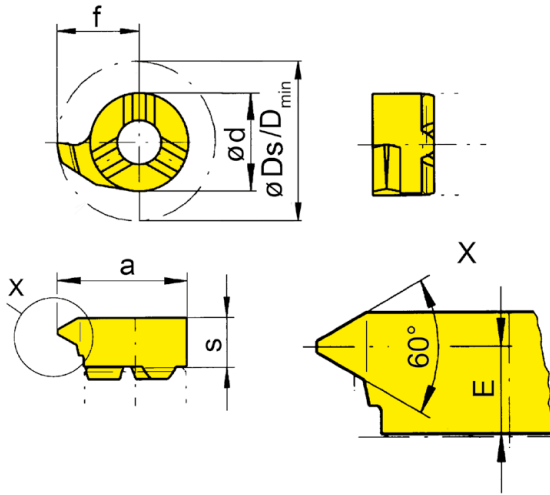

C

R = rechts wie gezeichnet
R = right hand version shown

L = links spiegelbildlich
L = left hand version

▲ ab Lager
on stock

HM-Sorten
Carbide grades
Δ 4 Wochen
4 weeks

Bestellnummer Part number	P	P _{max}	E	s	f	a	d	Ds	D _{min}	HIS	HM-Sorten Carbide grades			
											MG12	EG55	TH35	TN35
R111.0205.01	0,5	0,75	3,5	4,15	6,7	10,7	8	13,4	11	308080R	▲	▲	▲	▲
R111.0510.01	1	1,25	3,3	4,15	6,7	10,7	8	13,4	11	308080R	▲	▲	▲	▲
R111.0815.01	1,5	1,75	3,3	4,15	6,7	10,7	8	13,4	11	308080R	▲	▲	▲	▲
R111.1020.01	2	2	3	4,15	6,7	10,7	8	13,4	11	308080R	▲	▲	▲	▲
R111.1325.01	2,5	2,5	2,8	4,15	6,7	10,7	8	13,4	11	308080R	Δ	▲	▲	▲
L111.0205.01	0,5	0,75	3,5	4,15	6,7	10,7	8	13,4	11	308080L	Δ	Δ	Δ	▲
L111.0510.01	1	1,25	3,3	4,15	6,7	10,7	8	13,4	11	308080L	▲	Δ	Δ	▲
L111.0815.01	1,5	1,75	3,3	4,15	6,7	10,7	8	13,4	11	308080L	▲	Δ	Δ	▲
L111.1020.01	2	2	3	4,15	6,7	10,7	8	13,4	11	308080L	Δ	Δ	Δ	▲
L111.1325.01	2,5	2,5	2,8	4,15	6,7	10,7	8	13,4	11	308080L	Δ	Δ	Δ	▲
	P	o	•	•	•	•	•	•	•	•	•	•	•	•
	M	-	o	•	•	•	•	•	•	•	•	•	•	•
	K	-	o	•	•	•	•	•	•	•	•	•	•	•
	N	-	-	•	•	•	•	•	•	•	•	•	•	•
	S	-	-	•	•	•	•	•	•	•	•	•	•	•
	H	-	-	-	-	-	-	-	-	-	-	-	-	-

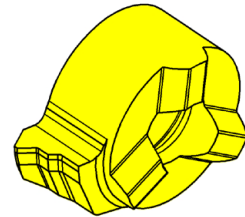
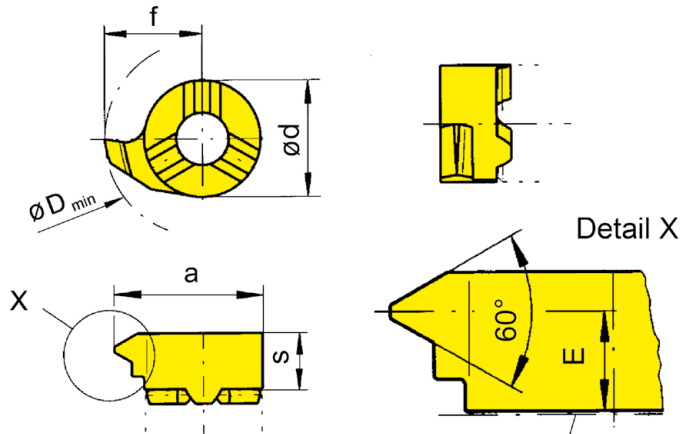

R = rechts wie gezeichnet
R = right hand version shown

L = links spiegelbildlich
L = left hand version

▲ ab Lager
on stock

HM-Sorten
Carbide grades
Δ 4 Wochen
4 weeks

Bestellnummer Part number	P	E	f	a	d	s	D _{min}	HIS	MG12	EG55	TI25	TN35
R111.0510.02	1	3,3	6,7	10,7	8	4,15	11	308080R		▲		▲
R111.0815.02	1,5	3,3	6,7	10,7	8	4,15	11	308080R	▲	▲	Δ	▲
R111.1020.02	2	3	6,7	10,7	8	4,15	11	308080R		▲	Δ	▲
R111.1325.02	2,5	2,8	6,7	10,7	8	4,15	11	308080R		▲		▲
R111.1630.02	3	2,8	6,7	10,7	8	4,15	11	308080R		▲	Δ	▲
L111.0510.02	1	3,3	6,7	10,7	8	4,15	11	308080L		Δ		▲
L111.0815.02	1,5	3,3	6,7	10,7	8	4,15	11	308080L	Δ	▲	Δ	▲
L111.1020.02	2	3	6,7	10,7	8	4,15	11	308080L		▲		▲
L111.1325.02	2,5	2,8	6,7	10,7	8	4,15	11	308080L		Δ		Δ
L111.1630.02	3	2,8	6,7	10,7	8	4,15	11	308080L		Δ		Δ
P	o	•	•	•								
M	-	o	•	•								
K	-	o	•	•								
N	-	-	•	•								
S	-	-	•	•								
H	-	-	-	-								



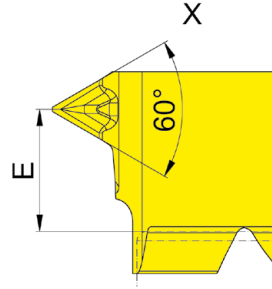
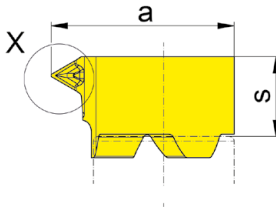
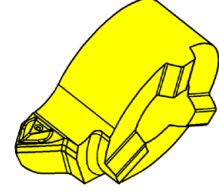
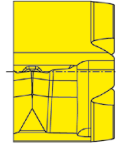
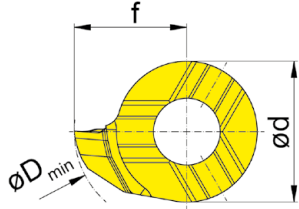
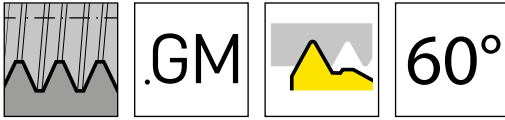

R = rechts wie gezeichnet
R = right hand version shown

▲ ab Lager
on stock

HM-Sorten
Carbide grades
Δ 4 Wochen
4 weeks

Bestellnummer Part number	P	P _{max}	E	f	a	d	s	D _{min}	HIS	EG55
RS111.0205.GM1	0,5	0,75	3,1	6,7	10,7	8	4,1	11	308080R	▲
RS111.0510.GM1	1	1,25	3,1	6,7	10,7	8	4,1	11	308080R	▲
RS111.0815.GM1	1,5	1,75	3,1	6,7	10,7	8	4,1	11	308080R	▲
RS111.1020.GM1	2	2	3,1	6,7	10,7	8	4,1	11	308080R	▲
LS111.0205.GM1	0,5	0,75	3,1	6,7	10,7	8	4,1	11	308080L	▲
LS111.0510.GM1	1	1,25	3,1	6,7	10,7	8	4,1	11	308080L	▲
LS111.0815.GM1	1,5	1,75	3,1	6,7	10,7	8	4,1	11	308080L	▲
LS111.1020.GM1	2	2	3,1	6,7	10,7	8	4,1	11	308080L	▲
	P	●								
	M	o								
	K	o								
	N	-								
	S	-								
	H	-								

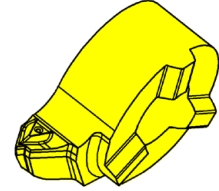
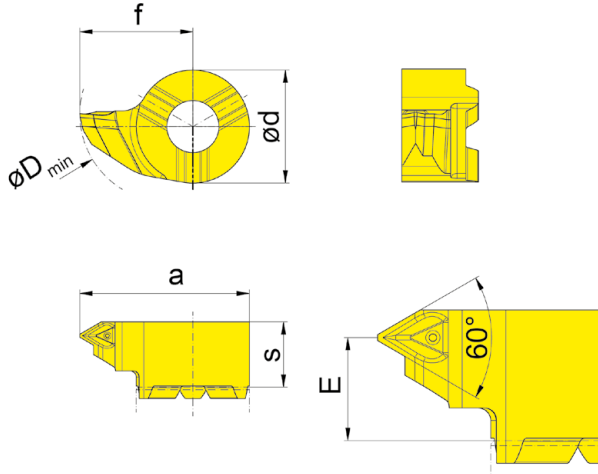
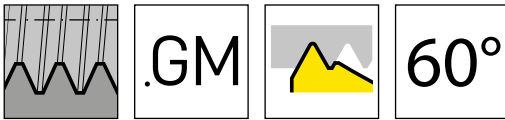

R = rechts wie gezeichnet
R = right hand version shown

▲ ab Lager
on stock

HM-Sorten
Carbide grades
Δ 4 Wochen
4 weeks

Bestellnummer Part number	P	E	f	a	d	s	D _{min}	HIS	EG55
RS111.0510.GM2	1	3,1	6,7	10,7	8	4,1	11	308080R	▲
RS111.0815.GM2	1,5	3,1	6,7	10,7	8	4,1	11	308080R	▲
RS111.1020.GM2	2	3,1	6,7	10,7	8	4,1	11	308080R	▲
LS111.0510.GM2	1	3,1	6,7	10,7	8	4,1	11	308080L	▲
LS111.0815.GM2	1,5	3,1	6,7	10,7	8	4,1	11	308080L	▲
LS111.1020.GM2	2	3,1	6,7	10,7	8	4,1	11	308080L	▲
	P	●							
	M	o							
	K	o							
	N	-							
	S	-							
	H	-							

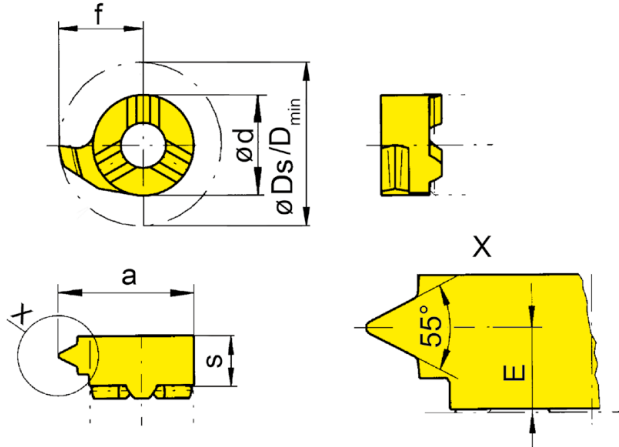

C

R = rechts wie gezeichnet
R = right hand version shown

L = links spiegelbildlich
L = left hand version

▲ ab Lager
on stock

HM-Sorten
Carbide grades
Δ 4 Wochen
4 weeks

Bestellnummer Part number	TPI	E	s	f	a	d	Ds	D _{min}	HIS	HM-Sorten Carbide grades			
										EG55	TA45	TN35	
R111.5514.02	14	2,5	4,15	6,7	10,7	8	13,4	11	308080R	▲		▲	
R111.5519.02	19	2,9	4,15	6,7	10,7	8	13,4	11	308080R	▲	Δ	▲	
L111.5514.02	14	2,5	4,15	6,7	10,7	8	13,4	11	308080L	Δ		▲	
L111.5519.02	19	2,9	4,15	6,7	10,7	8	13,4	11	308080L		Δ	▲	
										P	●	●	●
										M	○	●	●
										K	○	●	●
										N	-	●	●
										S	-	●	●
										H	-	-	-

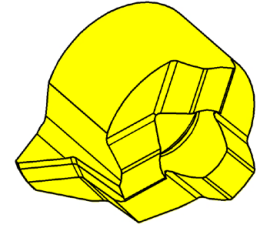
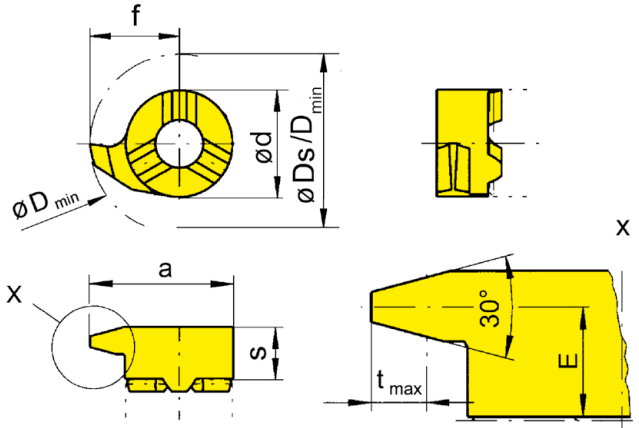

R = rechts wie gezeichnet
R = right hand version shown

L = links spiegelbildlich
L = left hand version

▲ ab Lager
on stock

HM-Sorten
Carbide grades
Δ 4 Wochen
4 weeks

Bestellnummer Part number	P	E	f	a	d	s	D _{min}	D _s	HIS	MG12	EG55	TN35
R111.1015.01	1,5	3,5	6,7	10,7	8	4,15	11	13,4	308080R		▲	▲
R111.1220.01	2	3,3	6,7	10,7	8	4,15	11	13,4	308080R		▲	▲
R111.1730.01	3	3	6,7	10,7	8	4,15	11	13,4	308080R	Δ	▲	▲
R111.2240.01	4	2,5	6,7	10,7	8	4,15	11	13,4	308080R		▲	▲
L111.1015.01	1,5	3,5	6,7	10,7	8	4,15	11	13,4	308080L		Δ	Δ
L111.1220.01	2	3,3	6,7	10,7	8	4,15	11	13,4	308080L		▲	▲
L111.1730.01	3	3	6,7	10,7	8	4,15	11	13,4	308080L	Δ	▲	▲
L111.2240.01	4	2,5	6,7	10,7	8	4,15	11	13,4	308080L		▲	▲
	P	o	•	•								
	M	-	o	•								
	K	-	o	•								
	N	-	-	•								
	S	-	-	•								
	H	-	-	-								



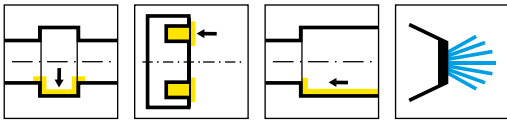

C



Abbildung = rechtsschneidend
Picture = right hand cutting version

Bestellnummer Part number	d	l ₁	l ₂	h	l ₄	HWS
B114.0012.00	12	75	19,5	11	40	311090R • 311090L
B114.0012.01	12	100	34	11	50	311090R • 311090L
B114.0012.02	12	110	45	11	50	311090R • 311090L
B114.0012.03	12	130	64	11	50	311090R • 311090L
B114.0016.00	16	80	19,5	15	40	311090R • 311090L
B114.0016.01	16	100	34	15	50	311090R • 311090L
B114.0016.02	16	110	45	15	50	311090R • 311090L
B114.0016.03	16	130	64	15	50	311090R • 311090L

w, a, tmax und f siehe Schneidplatten
w, a, tmax and f see inserts

Ersatzteile

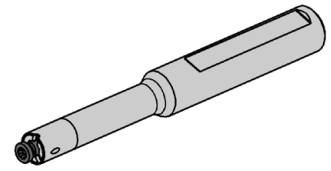
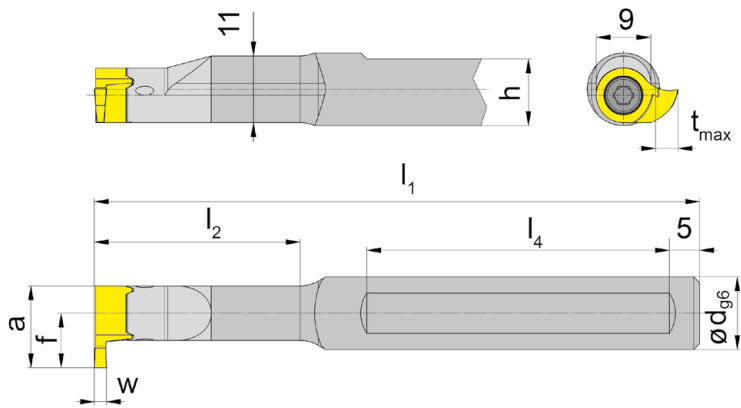
Spare Parts

Klemmhalter Toolholder	Spannschraube Clamping Screw	TORX PLUS®-Schlüssel TORX PLUS® Wrench
B114...	4.12T15EP	T15PQ



Abbildung = rechtsschneidend
Picture = right hand cutting version

Bestellnummer Part number	d	l ₁	l ₂	h	l ₄	HWS
B114.0012.2.00	12	75	19,5	11	40	311090R • 311090L
B114.0012.2.01	12	100	34	11	50	311090R • 311090L
B114.0012.2.02	12	110	45	11	50	311090R • 311090L
B114.0012.2.03	12	130	64	11	50	311090R • 311090L
B114.0016.2.00	16	80	19,5	14	40	311090R • 311090L
B114.0016.2.01	16	100	34	14	50	311090R • 311090L
B114.0016.2.02	16	110	45	14	50	311090R • 311090L
B114.0016.2.03	16	130	64	14	50	311090R • 311090L

w, a, tmax und f siehe Schneidplatten
w, a, tmax and f see inserts

Ersatzteile
Spare Parts

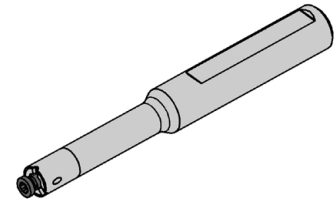
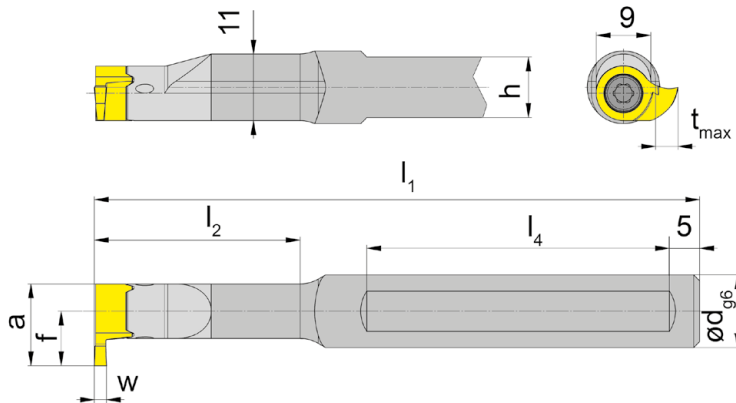
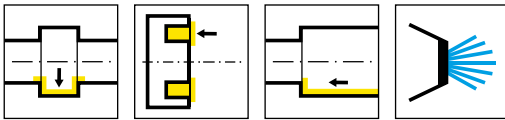
Klemmhalter Toolholder	Spannschraube Clamping Screw	TORX PLUS®-Schlüssel TORX PLUS® Wrench
B114...	4.12T15EP	T15PQ

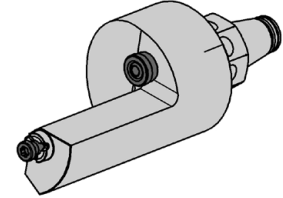
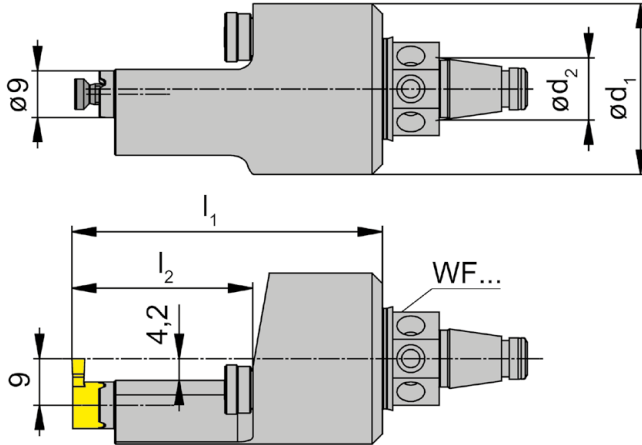
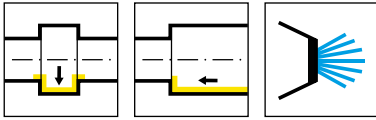

Bestellnummer Part number	d_1	l_1	d_2	l_2	HWS	HMS
WFB.2H0.114	33	60	12	35	311090R • 311090L	WFB
WFB.3H0.114	50	80	20	32	311090R • 311090L	WFB

Ersatzteile

Spare Parts

Klemmhalter Toolholder	Spannschraube Clamping Screw	Kugelspritzdüse Coolant spray nozzle	TORX PLUS®-Schlüssel TORX PLUS® Wrench
WFB...	4.12T15EP	020.0806.3116	T15PQ



Abbildung = rechtsschneidend
Picture = right hand cutting version

Bestellnummer Part number	d	l_1	l_2	h	l_4	HWS
RBA114.0016.01	16	99,7	28,7	15	50	311090R • 311090L
RBA114.0016.02	16	109,7	39,7	15	50	311090R • 311090L
LBA114.0016.01	16	99,7	28,7	15	50	311090R • 311090L
LBA114.0016.02	16	109,7	39,7	15	50	311090R • 311090L

w, a, s, tmax und f siehe Schneidplatten
w, a, s, tmax and f see inserts

Ersatzteile
Spare Parts

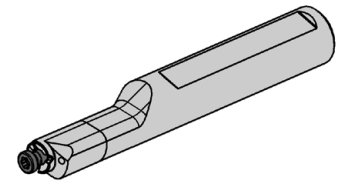
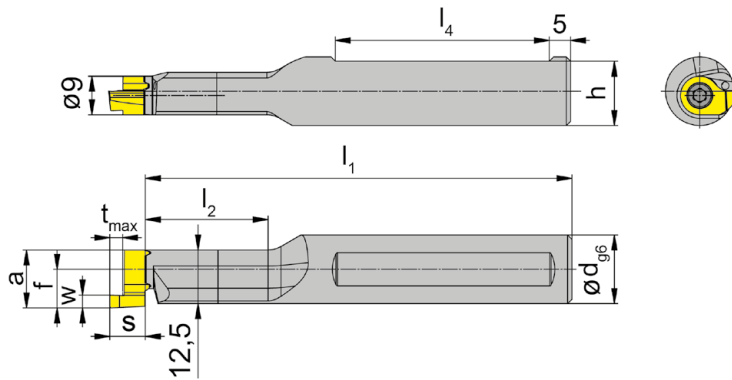
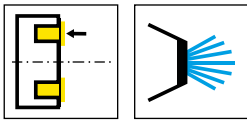
Klemmhalter Toolholder	Spannschraube Clamping Screw	TORX PLUS®-Schlüssel TORX PLUS® Wrench
R/LBA114...	4.12T15EP	T15PQ

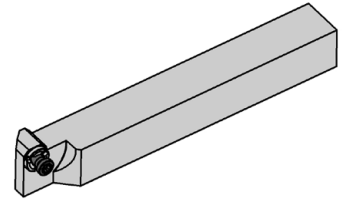
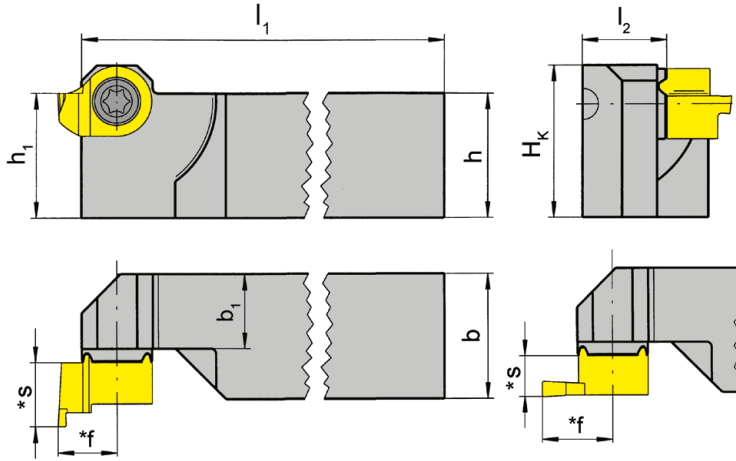
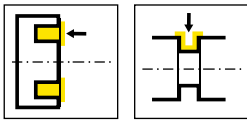

R = rechts wie gezeichnet
R = right hand version shown

L = links spiegelbildlich
L = left hand version

Bestellnummer Part number	h	b	l ₁	l ₂	h ₁	b ₁	H _k	HWS
RHC114.1212.01	12	12	122	11,2	12	9,5	15,6	311090R • 311090L
RHC114.1616.01	16	16	122	11,2	16	9,5	19,6	311090R • 311090L
RHC114.2020.01	20	20	122	15,2	20	13,5	23,6	311090R • 311090L
RHC114.2525.01	25	25	147	20,2	25	18,5	28,6	311090R • 311090L
LHC114.1212.01	12	12	122	11,2	12	9,5	15,6	311090R • 311090L
LHC114.1616.01	16	16	122	11,2	16	9,5	19,6	311090R • 311090L
LHC114.2020.01	20	20	122	15,2	20	13,5	23,6	311090R • 311090L
LHC114.2525.01	25	25	147	20,2	25	18,5	28,6	311090R • 311090L

* siehe Schneidplatten
* see inserts

Ersatzteile
Spare Parts

Klemmhalter Toolholder	Spannschraube Clamping Screw	TORX PLUS®-Schlüssel TORX PLUS® Wrench
R/LHC114...	4.12T15EP	T15PQ

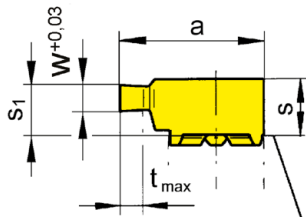
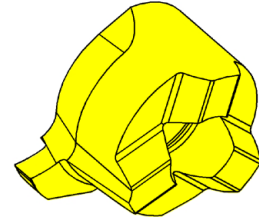
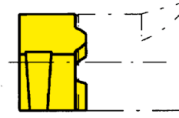
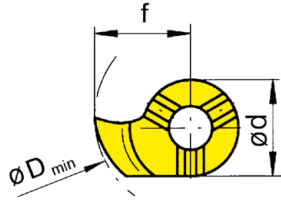
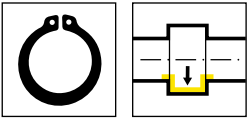

Klemmhalter Stirnseite

Toolholder face

R = rechts wie gezeichnet
R = right hand version shown

L = links spiegelbildlich
L = left hand version

▲ ab Lager
on stock

HM-Sorten
Carbide grades
Δ 4 Wochen
4 weeks

Bestellnummer Part number	w	Nw	s	f	a	s ₁	d	t _{max}	D _{min}	HIS	EG55	TN35
R114.0070.00	0,74	0,7	5,5	9	13,5	5,3	9	1,2	14	311090R	▲	▲
R114.0080.00	0,84	0,8	5,5	9	13,5	5,3	9	1,3	14	311090R	▲	▲
R114.0090.00	0,94	0,9	5,5	9	13,5	5,3	9	1,5	14	311090R	▲	▲
L114.0070.00	0,74	0,7	5,5	9	13,5	5,3	9	1,2	14	311090L		▲
L114.0080.00	0,84	0,8	5,5	9	13,5	5,3	9	1,3	14	311090L	Δ	▲
L114.0090.00	0,94	0,9	5,5	9	13,5	5,3	9	1,5	14	311090L	▲	▲

Zapfenausführung
not face cutting, limited depth of cut

	EG55	TN35
P	●	●
M	○	●
K	○	●
N	-	●
S	-	●
H	-	-



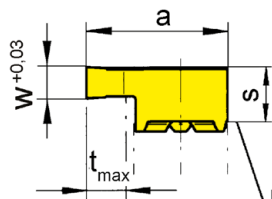
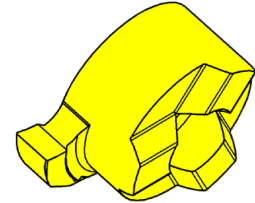
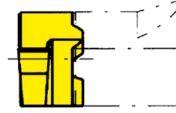
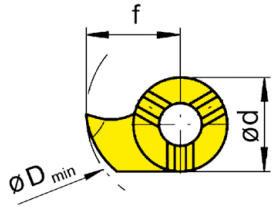
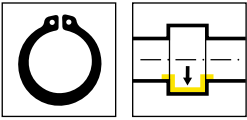

Klemmhalter Stirnseite
Toolholder face

R = rechts wie gezeichnet
R = right hand version shown

L = links spiegelbildlich
L = left hand version

▲ ab Lager
on stock

HM-Sorten
Carbide grades
Δ 4 Wochen
4 weeks

Bestellnummer Part number	w	Nw	s	f	a	d	t _{max}	D _{min}	HIS	EG55	TH35	TN35
R114.0110.00	1,19	1,1	5,3	9	13,5	9	4	14	311090R	▲	▲	▲
R114.0130.00	1,39	1,3	5,3	9	13,5	9	4	14	311090R	▲	▲	▲
R114.0160.00	1,69	1,6	5,3	9	13,5	9	4	14	311090R	▲	▲	▲
L114.0110.00	1,19	1,1	5,3	9	13,5	9	4	14	311090L	▲	▲	▲
L114.0130.00	1,39	1,3	5,3	9	13,5	9	4	14	311090L	▲	▲	▲
L114.0160.00	1,69	1,6	5,3	9	13,5	9	4	14	311090L	▲	▲	▲
P	●	●	●									
M	○	○	○									
K	○	○	○									
N	-	●	●									
S	-	●	●									
H	-	-	-									

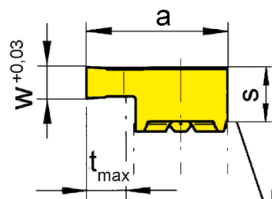
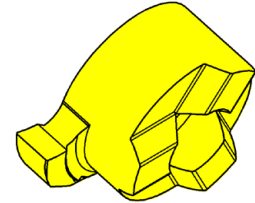
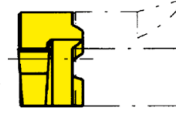
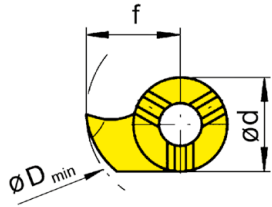
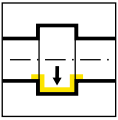

Klemmhalter Stirnseite
Toolholder face

R = rechts wie gezeichnet
R = right hand version shown

L = links spiegelbildlich
L = left hand version

▲ ab Lager
on stock

HM-Sorten
Carbide grades
Δ 4 Wochen
4 weeks

Bestellnummer Part number	w	s	f	a	d	t _{max}	D _{min}	HIS	MG12	EG55	TH35	TN35
R114.0150.00	1,5	5,3	9	13,5	9	4	14	311090R	▲	▲	▲	▲
R114.0200.00	2	5,3	9	13,5	9	4	14	311090R	▲	▲	▲	▲
R114.0250.00	2,5	5,3	9	13,5	9	4	14	311090R	▲	▲	▲	▲
R114.0300.00	3	5,3	9	13,5	9	4	14	311090R	▲	▲	▲	▲
L114.0150.00	1,5	5,3	9	13,5	9	4	14	311090L	▲	▲	▲	▲
L114.0200.00	2	5,3	9	13,5	9	4	14	311090L	▲	▲	▲	▲
L114.0250.00	2,5	5,3	9	13,5	9	4	14	311090L	▲	▲	▲	▲
L114.0300.00	3	5,3	9	13,5	9	4	14	311090L	▲	▲	▲	▲
									P	o	•	•
									M	-	o	•
									K	-	o	•
									N	-	-	•
									S	-	-	•
									H	-	-	-



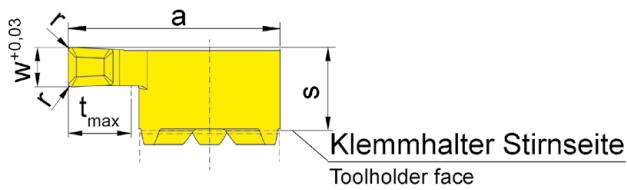
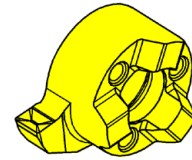
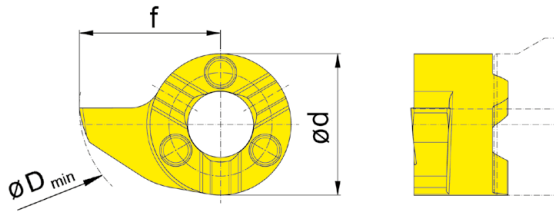
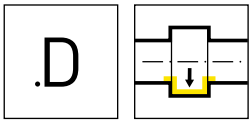

R = rechts wie gezeichnet
R = right hand version shown

L = links spiegelbildlich
L = left hand version

▲ ab Lager
on stock

HM-Sorten
Carbide grades
Δ 4 Wochen
4 weeks

Bestellnummer Part number	w	s	f	a	r	d	t _{max}	D _{min}	HIS	EG55	TF45	TH35	TN35
RS114.0200.D2	2	5,3	9	13,5	0,2	9	4	14	311090R	▲	▲	▲	▲
RS114.0250.D2	2,5	5,3	9	13,5	0,2	9	4	14	311090R	▲	▲	▲	▲
RS114.0300.D2	3	5,3	9	13,5	0,2	9	4	14	311090R	▲	▲	▲	▲
LS114.0200.D2	2	5,3	9	13,5	0,2	9	4	14	311090L	▲	Δ	▲	▲
LS114.0250.D2	2,5	5,3	9	13,5	0,2	9	4	14	311090L	▲	Δ	▲	▲
LS114.0300.D2	3	5,3	9	13,5	0,2	9	4	14	311090L	▲	▲	▲	▲
P	●	●	●	●	●	●	●	●					
M	○	●	●	●	●	●	●	●					
K	○	●	●	●	●	●	●	●					
N	-	●	●	●	●	●	●	●					
S	-	●	●	●	●	●	●	●					
H	-	-	-	-	-	-	-	-					

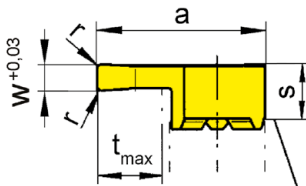
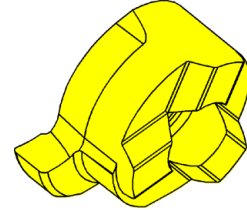
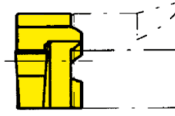
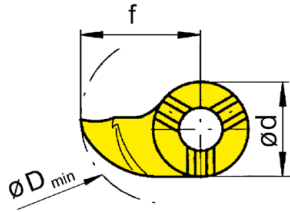
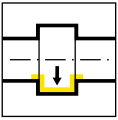

Klemmhalter Stirnseite
Toolholder face

R = rechts wie gezeichnet
R = right hand version shown

L = links spiegelbildlich
L = left hand version

▲ ab Lager
on stock

HM-Sorten
Carbide grades
Δ 4 Wochen
4 weeks

Bestellnummer Part number	w	s	f	a	r	d	t _{max}	D _{min}	HIS	EG55	TH35	TI25	TN35
R114.0150.1.02	1,5	5,3	11,3	15,8	0,2	9	6,5	16,5	311090R	▲	▲		▲
R114.0200.1.02	2	5,3	11,3	15,8	0,2	9	6,5	16,5	311090R	▲	▲	▲	▲
R114.0250.1.02	2,5	5,3	11,3	15,8	0,2	9	6,5	16,5	311090R	▲	▲		▲
R114.0300.1.02	3	5,3	11,3	15,8	0,2	9	6,5	16,5	311090R	▲	▲		▲
L114.0150.1.02	1,5	5,3	11,3	15,8	0,2	9	6,5	16,5	311090L	▲	▲		▲
L114.0200.1.02	2	5,3	11,3	15,8	0,2	9	6,5	16,5	311090L	▲	▲	Δ	▲
L114.0250.1.02	2,5	5,3	11,3	15,8	0,2	9	6,5	16,5	311090L	▲	▲		▲
L114.0300.1.02	3	5,3	11,3	15,8	0,2	9	6,5	16,5	311090L	▲	▲		▲
										P	●	●	●
										M	○	●	●
										K	○	●	●
										N	-	●	●
										S	-	●	●
										H	-	-	-



Schneidplatte Insert

S114 $\emptyset \geq 16,5 \text{ mm}$

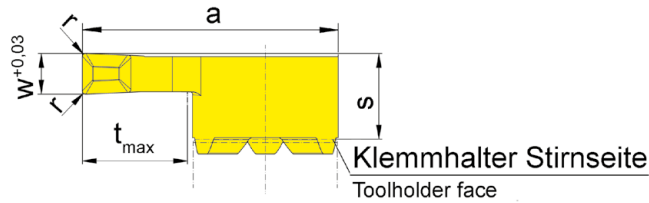
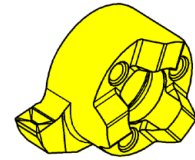
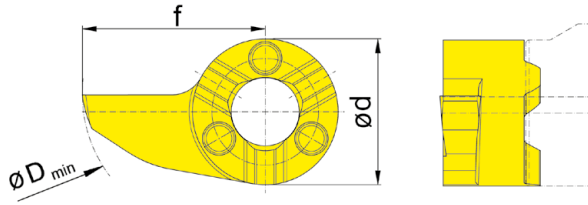
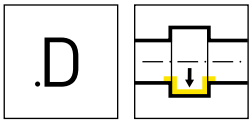

R = rechts wie gezeichnet
R = right hand version shown

L = links spiegelbildlich
L = left hand version

▲ ab Lager
on stock

HM-Sorten
Carbide grades
Δ 4 Wochen
4 weeks

Bestellnummer Part number	w	s	f	a	r	d	t _{max}	D _{min}	HIS	EG55	TH35
RS114.0200.1.D2	2	5,3	11,3	15,8	0,2	9	6,5	16,5	311090R	▲	▲
RS114.0250.1.D2	2,5	5,3	11,3	15,8	0,2	9	6,5	16,5	311090R	▲	▲
RS114.0300.1.D2	3	5,3	11,3	15,8	0,2	9	6,5	16,5	311090R	▲	▲
LS114.0200.1.D2	2	5,3	11,3	15,8	0,2	9	6,5	16,5	311090L	▲	▲
LS114.0250.1.D2	2,5	5,3	11,3	15,8	0,2	9	6,5	16,5	311090L	Δ	▲
LS114.0300.1.D2	3	5,3	11,3	15,8	0,2	9	6,5	16,5	311090L	▲	▲
										P	●
										M	○
										K	○
										N	-
										S	-
										H	-

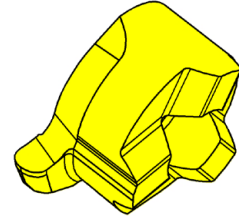
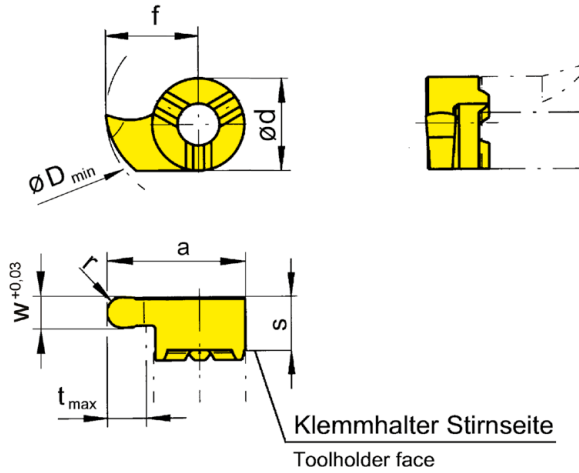
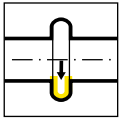

R = rechts wie gezeichnet
R = right hand version shown

L = links spiegelbildlich
L = left hand version

▲ ab Lager
on stock

HM-Sorten
Carbide grades
Δ 4 Wochen
4 weeks

Bestellnummer Part number	w	s	f	a	r	d	t _{max}	D _{min}	HIS	EG55	TH35	TI25	TN35
R114.0004.08	0,8	5,3	9	13,5	0,4	9	4	14	311090R			▲	
R114.0006.12	1,2	5,3	9	13,5	0,6	9	4	14	311090R	▲	▲		▲
R114.0009.18	1,8	5,3	9	13,5	0,9	9	4	14	311090R	▲	▲		▲
R114.0010.20	2	5,3	9	13,5	1	9	4	14	311090R	▲	▲		▲
R114.0011.22	2,2	5,3	9	13,5	1,1	9	4	14	311090R	▲	▲		▲
R114.0015.30	3	5,3	9	13,5	1,5	9	4	14	311090R	▲	▲		▲
R114.0020.40	4	5,3	9	13,5	2	9	4	14	311090R	▲	▲		
L114.0004.08	0,8	5,3	9	13,5	0,4	9	4	14	311090L			▲	
L114.0006.12	1,2	5,3	9	13,5	0,6	9	4	14	311090L	▲	▲		▲
L114.0009.18	1,8	5,3	9	13,5	0,9	9	4	14	311090L	▲	▲		▲
L114.0010.20	2	5,3	9	13,5	1	9	4	14	311090L	▲	▲		▲
L114.0011.22	2,2	5,3	9	13,5	1,1	9	4	14	311090L	Δ	▲		▲
L114.0015.30	3	5,3	9	13,5	1,5	9	4	14	311090L	▲	▲		▲
L114.0020.40	4	5,3	9	13,5	2	9	4	14	311090L	Δ	Δ		
P	•	•	•	•	•	•	•	•					
M	o	•	•	•	•	•	•	•					
K	o	•	•	•	•	•	•	•					
N	-	•	•	•	•	•	•	•					
S	-	•	•	•	•	•	•	•					
H	-	-	-	-	-	-	-	-					



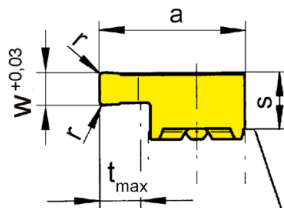
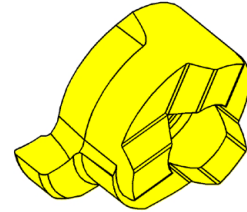
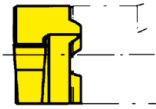
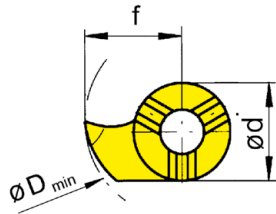
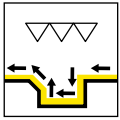

Klemmhalter Stirnseite
Toolholder face

R = rechts wie gezeichnet
R = right hand version shown

L = links spiegelbildlich
L = left hand version

▲ ab Lager
on stock

HM-Sorten
Carbide grades
Δ 4 Wochen
4 weeks

Bestellnummer Part number	w	s	f	a	r	d	t _{max}	D _{min}	HIS	MG12	EG55	TH35	TI25	TN35
R114.0200.02	2	5,3	9	13,5	0,2	9	4	14	311090R	▲	▲	▲	▲	▲
L114.0200.02	2	5,3	9	13,5	0,2	9	4	14	311090L	▲	▲	▲	▲	▲
P	o	•	•	•	•	•	•	•	•	•	•	•	•	•
M	-	o	•	•	•	•	•	•	•	•	•	•	•	•
K	-	o	•	•	•	•	•	•	•	•	•	•	•	•
N	-	-	•	•	•	•	•	•	•	•	•	•	•	•
S	-	-	•	•	•	•	•	•	•	•	•	•	•	•
H	-	-	-	-	-	-	-	-	-	-	-	-	-	-

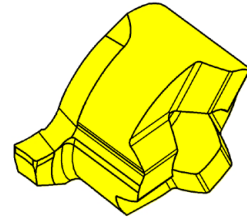
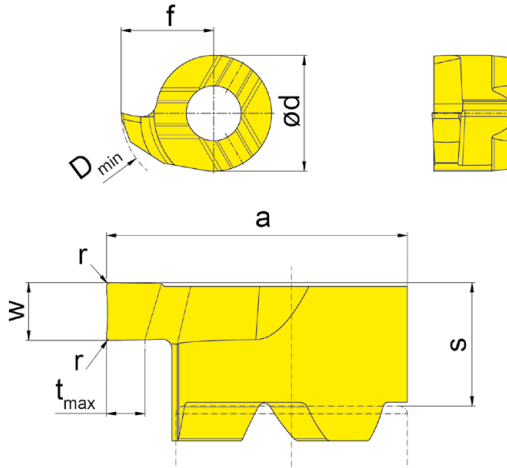
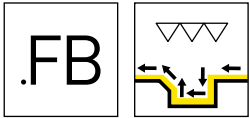

R = rechts wie gezeichnet
R = right hand version shown

L = links spiegelbildlich
L = left hand version

▲ ab Lager
on stock

HM-Sorten
Carbide grades
Δ 4 Wochen
4 weeks

Bestellnummer Part number	w	s	f	a	r	d	t _{max}	D _{min}	HIS	EG35
R114.FB10.01	1	5,3	9	13,5	0,1	9	4	14	311090R	▲
R114.FB15.01	1,5	5,3	9	13,5	0,1	9	4	14	311090R	▲
L114.FB10.01	1	5,3	9	13,5	0,1	9	4	14	311090L	▲
L114.FB15.01	1,5	5,3	9	13,5	0,1	9	4	14	311090L	▲

P	●
M	●
K	○
N	-
S	-
H	-

Berechnung der kleinstmöglichen Nutbreite w_x
Calculation of the smallest possible width of groove w_x

Beispiel R114.FB10.01
Example

$w_x = 2 \times \text{Schneidbreite } w - 2 \times \text{Eckenradius Schneidplatte } R$

$w_x = 2 \times \text{Width of insert } w - 2 \times \text{Corner radius insert } R$

$w_x = 2 \times 1 \text{ mm} - 2 \times 0,1 \text{ mm}$

$w_x = 1,8 \text{ mm}$

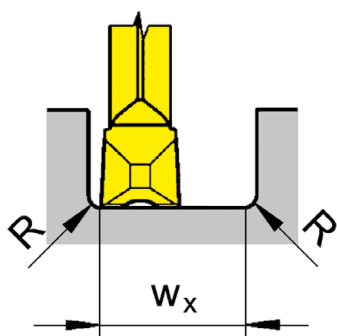

Bearbeitungsablauf
Processing flow

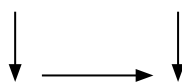

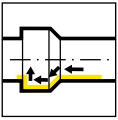

C

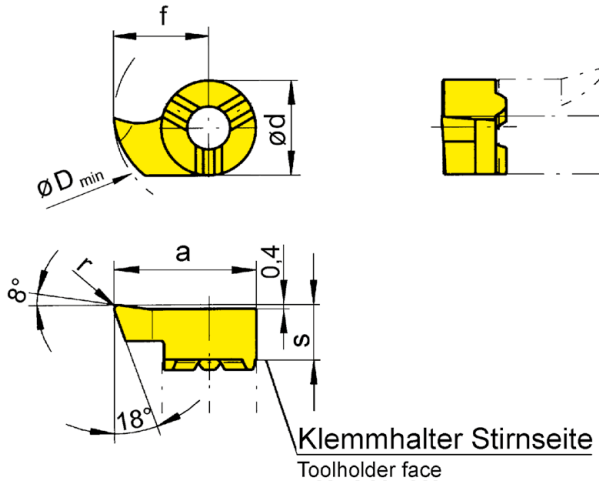

R = rechts wie gezeichnet
R = right hand version shown

L = links spiegelbildlich
L = left hand version

▲ ab Lager
on stock

HM-Sorten
Carbide grades
Δ 4 Wochen
4 weeks

Bestellnummer Part number	s	f	a	r	d	D _{min}	HIS	MG12	EG55	TH35	TI25	TN35
R114.1890.02	5,3	8,7	13,2	0,2	9	13,8	311090R	▲	▲	▲	Δ	▲
L114.1890.02	5,3	8,7	13,2	0,2	9	13,8	311090L	▲	▲	▲	Δ	▲
P	o	•	•	•	•							
M	-	o	•	•	•							
K	-	o	•	•	•							
N	-	-	•	•	•							
S	-	-	•	•	•							
H	-	-	-	-	-							

Schneidplatte Insert

S114

$\varnothing \geq 13,8 \text{ mm}$

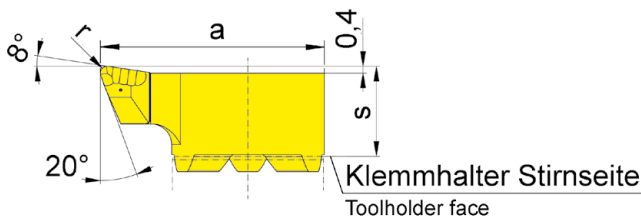
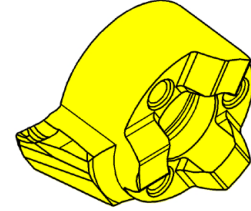
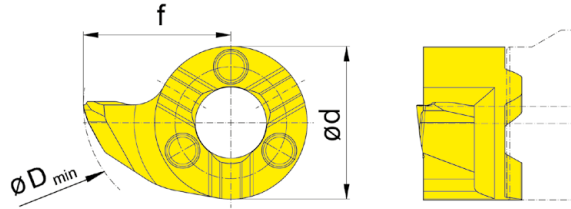
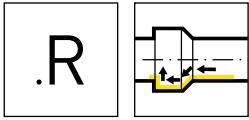

R = rechts wie gezeichnet
R = right hand version shown

L = links spiegelbildlich
L = left hand version

▲ ab Lager
on stock

HM-Sorten
Carbide grades
Δ 4 Wochen
4 weeks

Bestellnummer Part number	s	f	a	r	d	D _{min}	HIS	EG55	TH35
RS114.1890.R2	5,3	8,7	13,2	0,2	9	13,8	311090R	▲	▲
RS114.1890.R4	5,3	8,7	13,2	0,4	9	13,8	311090R	▲	▲
LS114.1890.R2	5,3	8,7	13,2	0,2	9	13,8	311090L	▲	▲
LS114.1890.R4	5,3	8,7	13,2	0,4	9	13,8	311090L	▲	▲
								P	●
								M	○
								K	○
								N	-
								S	-
								H	-



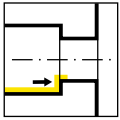

C

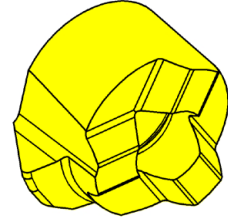
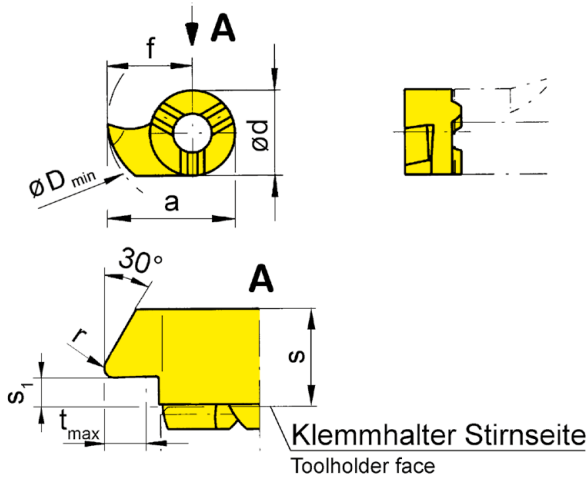

R = rechts wie gezeichnet
R = right hand version shown

L = links spiegelbildlich
L = left hand version

▲ ab Lager
on stock

HM-Sorten
Carbide grades
Δ 4 Wochen
4 weeks

Bestellnummer Part number	s	f	r	s ₁	d	t _{max}	D _{min}	HIS	EG55	TH35	TN35
R114.3090.02	5,5	8,7	0,2	2,4	9	3,5	13,8	311090R	▲	▲	▲
L114.3090.02	5,5	8,7	0,2	2,4	9	3,5	13,8	311090L	▲	▲	▲
P	●	●	●								
M	○	●	●								
K	○	●	●								
N	-	●	●								
S	-	●	●								
H	-	-	-								

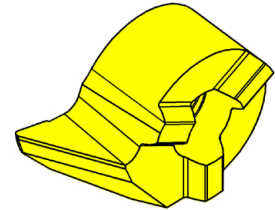
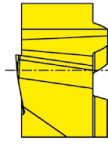
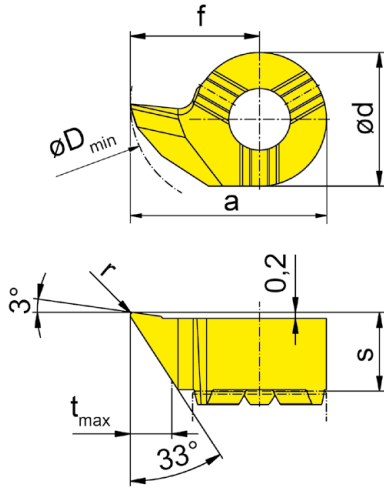
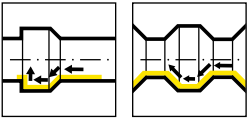

R = rechts wie gezeichnet
R = right hand version shown

L = links spiegelbildlich
L = left hand version

▲ ab Lager
on stock

HM-Sorten
Carbide grades
Δ 4 Wochen
4 weeks

Bestellnummer Part number	s	f	a	r	d	t _{max}	D _{min}	HIS	EG55
R114.3387.02	5,3	8,7	13,2	0,2	9	2,8	13,8	311090R	▲
R114.3387.04	5,3	8,7	13,2	0,4	9	2,8	13,8	311090R	▲
L114.3387.02	5,3	8,7	13,2	0,2	9	2,8	13,8	311090L	Δ
L114.3387.04	5,3	8,7	13,2	0,4	9	2,8	13,8	311090L	Δ
									P ●
									M ○
									K ○
									N -
									S -
									H -



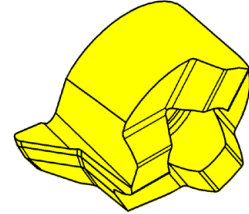
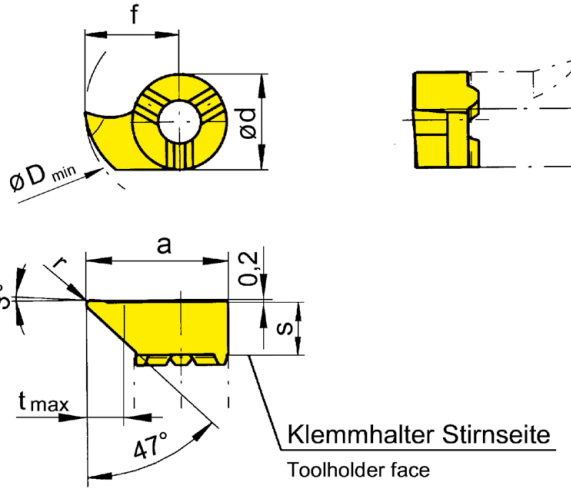
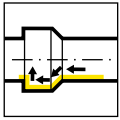

R = rechts wie gezeichnet
R = right hand version shown

L = links spiegelbildlich
L = left hand version

▲ ab Lager
on stock

HM-Sorten
Carbide grades
Δ 4 Wochen
4 weeks

Bestellnummer Part number	s	f	a	r	d	t _{max}	D _{min}	HIS	EG55	TH35	TI25	TN35
R114.4787.02	5,3	8,7	13,2	0,2	9	3	13,8	311090R	▲	▲	Δ	▲
R114.4787.04	5,3	8,7	13,2	0,4	9	3	13,8	311090R	▲	▲		
R114.4710.02	5,3	11	15,5	0,2	9	5	16	311090R	▲	▲		▲
L114.4787.02	5,3	8,7	13,2	0,2	9	3	13,8	311090L	▲	▲		▲
L114.4787.04	5,3	8,7	13,2	0,4	9	3	13,8	311090L	▲	▲		
L114.4710.02	5,3	11	15,5	0,2	9	5	16	311090L	Δ	▲		▲
P	●	●	●	●	●	●	●					
M	○	●	●	●	●	●	●					
K	○	●	●	●	●	●	●					
N	-	●	●	●	●	●	●					
S	-	●	●	●	●	●	●					
H	-	-	-	-	-	-	-					

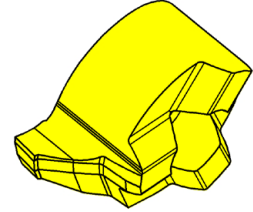
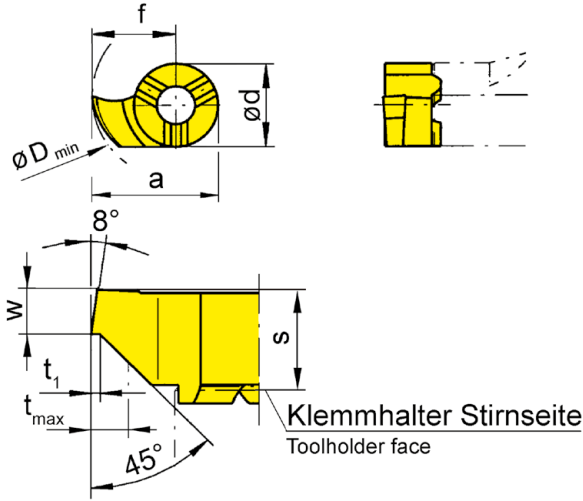
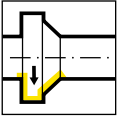

R = rechts wie gezeichnet
R = right hand version shown

L = links spiegelbildlich
L = left hand version

▲ ab Lager
on stock

HM-Sorten
Carbide grades
Δ 4 Wochen
4 weeks

Bestellnummer Part number	w	s	f	a	d	t_{max}	t_1	D_{min}	HIS	MG12	EG55	TI25	TN35
R114.0815.45	1,5	5,3	9	13,5	9	1,5	0,2	14	311090R	▲	▲	▲	Δ
L114.0815.45	1,5	5,3	9	13,5	9	1,5	0,2	14	311090L	Δ	▲	▲	▲
P	o	•	•	•									
M	-	o	•	•									
K	-	o	•	•									
N	-	-	•	•									
S	-	-	•	•									
H	-	-	-	-									



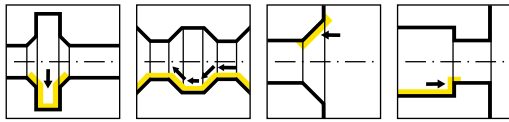

C

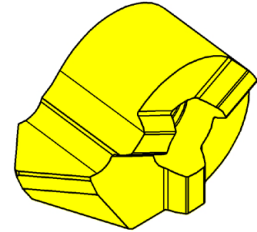
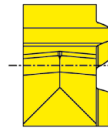
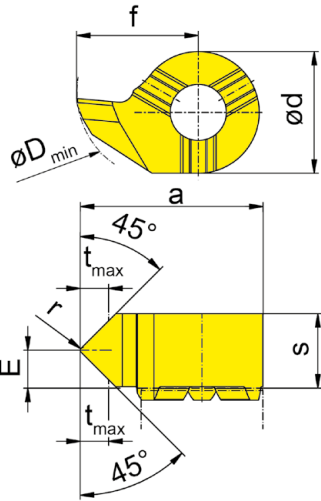

R = rechts wie gezeichnet
R = right hand version shown

L = links spiegelbildlich
L = left hand version

Bestellnummer Part number	E	s	f	r	d	t _{max}	D _{min}	HIS	EG55
R114.4545.02	2,8	5,5	9	0,2	9	2,1	14	311090R	▲
L114.4545.02	2,8	5,5	9	0,2	9	2,1	14	311090L	Δ

man. linke Platte (PD)
kommt nicht

P	●
M	○
K	○
N	-
S	-
H	-

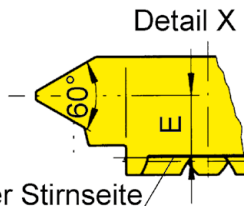
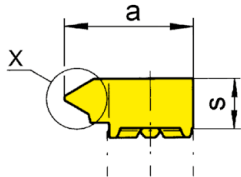
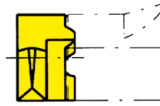
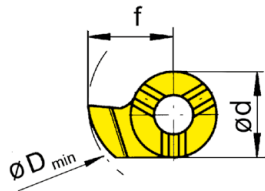

Klemhalter Stirnseite
Toolholder face

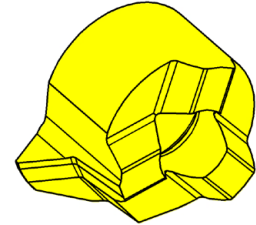

R = rechts wie gezeichnet
R = right hand version shown

L = links spiegelbildlich
L = left hand version

▲ ab Lager
on stock

HM-Sorten
Carbide grades
△ 4 Wochen
4 weeks

Bestellnummer Part number	P	P _{max}	E	f	a	d	s	D _{min}	HIS	EG55	TH35	TN35
R114.0205.01	0,5	0,75	4,8	9	9	9	5,5	14	311090R	▲	▲	▲
R114.1020.01	2	2	4,2	9	13,5	9	5,5	14	311090R	▲	▲	▲
R114.0510.01	1	1,25	4,7	9	13,5	9	5,5	14	311090R	▲	▲	▲
R114.1325.01	2,5	2,5	4,2	9	13,5	9	5,5	14	311090R	▲	▲	▲
R114.0815.01	1,5	1,75	4,5	9	13,5	9	5,5	14	311090R	▲	▲	▲
L114.0205.01	0,5	0,75	4,8	9	9	9	5,5	14	311090L	△	△	△
L114.1020.01	2	2	4,2	9	13,5	9	5,5	14	311090L	△	△	△
L114.0510.01	1	1,25	4,7	9	13,5	9	5,5	14	311090L	△	△	▲
L114.1325.01	2,5	2,5	4,2	9	13,5	9	5,5	14	311090L	△	▲	△
L114.0815.01	1,5	1,75	4,5	9	13,5	9	5,5	14	311090L	▲	▲	▲
P	●	●	●	●	●	●	●	●	●	●	●	●
M	○	○	○	○	○	○	○	○	○	○	○	○
K	○	○	○	○	○	○	○	○	○	○	○	○
N	-	-	-	-	-	-	-	-	-	-	-	-
S	-	-	-	-	-	-	-	-	-	-	-	-
H	-	-	-	-	-	-	-	-	-	-	-	-

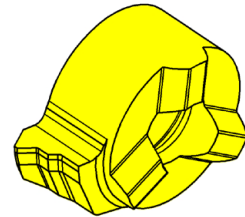
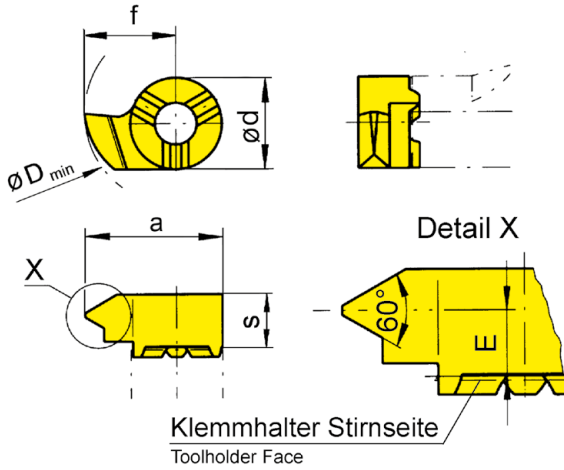

C

R = rechts wie gezeichnet
R = right hand version shown

L = links spiegelbildlich
L = left hand version

▲ ab Lager
on stock

HM-Sorten
Carbide grades
Δ 4 Wochen
4 weeks

Bestellnummer Part number	P	E	f	a	d	s	D _{min}	HIS	EG55	TN35
R114.0510.02	1	4,7	9	13,5	9	5,5	14	311090R	▲	▲
R114.0815.02	1,5	4,5	9	13,5	9	5,5	14	311090R	▲	▲
R114.1020.02	2	4,2	9	13,5	9	5,5	14	311090R	▲	▲
R114.1325.02	2,5	4,2	9	13,5	9	5,5	14	311090R	▲	▲
L114.0510.02	1	4,7	9	13,5	9	5,5	14	311090L	Δ	▲
L114.0815.02	1,5	4,5	9	13,5	9	5,5	14	311090L	Δ	▲
L114.1020.02	2	4,2	9	13,5	9	5,5	14	311090L	Δ	▲
L114.1325.02	2,5	4,2	9	13,5	9	5,5	14	311090L	Δ	▲
	P	●	●							
	M	○	●							
	K	○	●							
	N	-	●							
	S	-	●							
	H	-	-							

Schneidplatte Insert

S114

$\emptyset \geq 14 \text{ mm}$

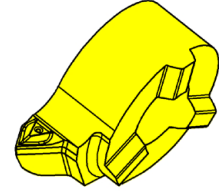
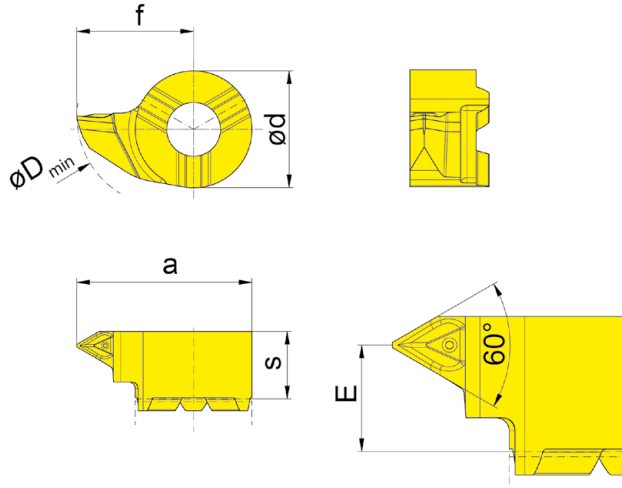
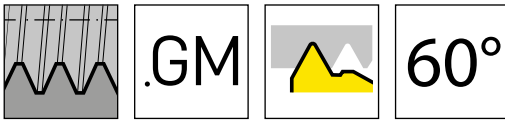

R = rechts wie gezeichnet
R = right hand version shown

L = links spiegelbildlich
L = left hand version

▲ ab Lager
on stock

HM-Sorten
Carbide grades
Δ 4 Wochen
4 weeks

Bestellnummer Part number	P	P _{max}	E	f	a	d	s	D _{min}	HIS	EG55
RS114.0205.GM1	0,5	0,75	4,1	9	13,5	9	5,2	14	311090R	▲
RS114.0510.GM1	1	1,25	4,1	9	13,5	9	5,2	14	311090R	▲
RS114.0815.GM1	1,5	1,75	4,1	9	13,5	9	5,2	14	311090R	▲
RS114.1020.GM1	2	2	4,1	9	13,5	9	5,2	14	311090R	▲
RS114.1325.GM1	2,5	2,5	4,1	9	13,5	9	5,2	14	311090R	▲
LS114.0205.GM1	0,5	0,75	4,1	9	13,5	9	5,2	14	311090L	▲
LS114.0510.GM1	1	1,25	4,1	9	13,5	9	5,2	14	311090L	▲
LS114.0815.GM1	1,5	1,75	4,1	9	13,5	9	5,2	14	311090L	▲
LS114.1020.GM1	2	2	4,1	9	13,5	9	5,2	14	311090L	▲
LS114.1325.GM1	2,5	2,5	4,1	9	13,5	9	5,2	14	311090L	▲
										P ●
										M o
										K o
										N -
										S -
										H -



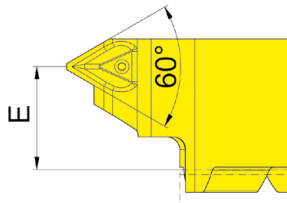
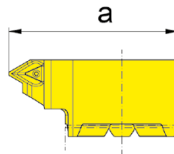
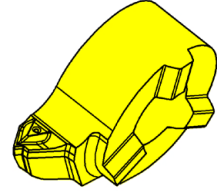
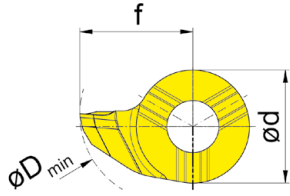
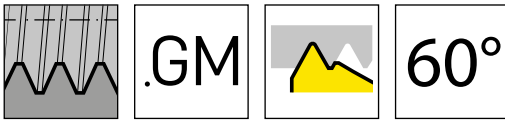

R = rechts wie gezeichnet
R = right hand version shown

L = links spiegelbildlich
L = left hand version

▲ ab Lager
on stock

HM-Sorten
Carbide grades
Δ 4 Wochen
4 weeks

Bestellnummer Part number	P	E	f	a	d	s	D _{min}	HIS	EG55
RS114.0510.GM2	1	4,1	9	13,5	9	5,2	14	311090R	▲
RS114.0815.GM2	1,5	4,1	9	13,5	9	5,2	14	311090R	▲
RS114.1020.GM2	2	4,1	9	13,5	9	5,2	14	311090R	▲
RS114.1325.GM2	2,5	4,1	9	13,5	9	5,2	14	311090R	▲
LS114.0510.GM2	1	4,1	9	13,5	9	5,2	14	311090L	▲
LS114.0815.GM2	1,5	4,1	9	13,5	9	5,2	14	311090L	▲
LS114.1020.GM2	2	4,1	9	13,5	9	5,2	14	311090L	▲
LS114.1325.GM2	2,5	4,1	9	13,5	9	5,2	14	311090L	▲
	P	●							
	M	o							
	K	o							
	N	-							
	S	-							
	H	-							

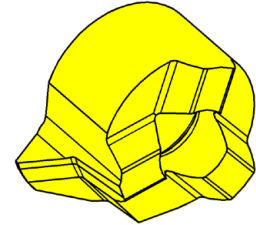
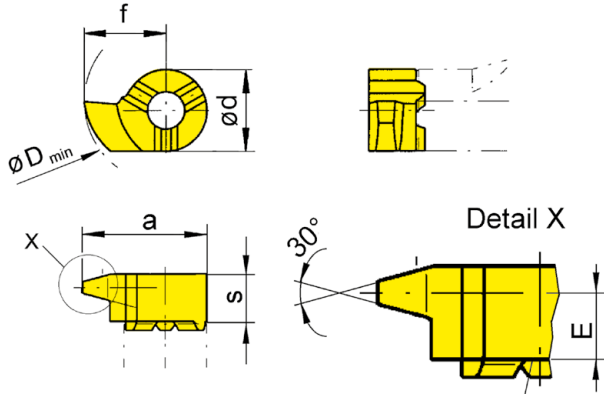

Klemhalter Stirnseite
Toolholder face

R = rechts wie gezeichnet
R = right hand version shown

L = links spiegelbildlich
L = left hand version

▲ ab Lager
on stock

HM-Sorten
Carbide grades
Δ 4 Wochen
4 weeks

Bestellnummer Part number	P	E	f	a	d	s	D _{min}	HIS	HM-Sorten Carbide grades		
									EG55	TN35	
R114.1730.01	3	4,3	9	13,5	9	5,5	14	311090R	▲	▲	
R114.2240.01	4	4	9	13,5	9	5,5	14	311090R	▲	▲	
R114.2750.01	5	3,55	9	13,5	9	5,5	14	311090R	▲	▲	
L114.2240.01	4	4	9	13,5	9	5,5	14	311090L	Δ	▲	
L114.2750.01	5	3,55	9	13,5	9	5,5	14	311090L	Δ	▲	
									P	●	●
									M	○	●
									K	○	●
									N	-	●
									S	-	●
									H	-	-

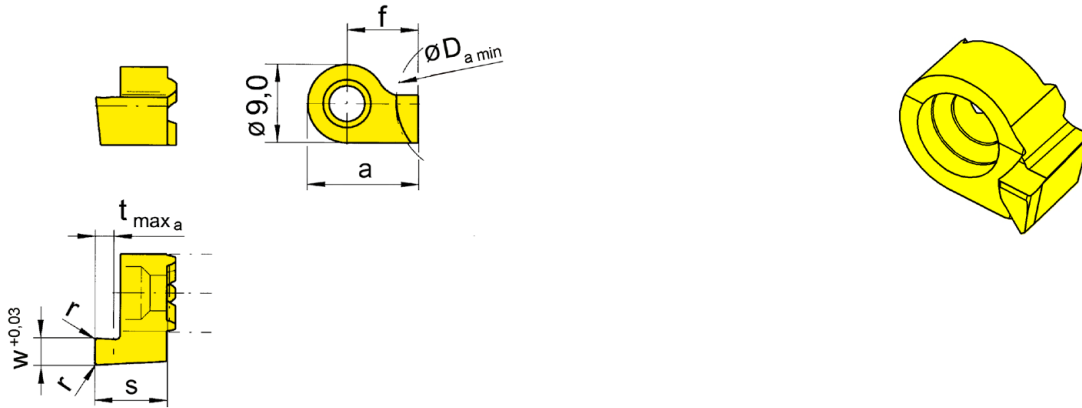
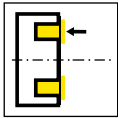

R = rechts wie gezeichnet
R = right hand version shown

L = links spiegelbildlich
L = left hand version

▲ ab Lager
on stock

HM-Sorten
Carbide grades
Δ 4 Wochen
4 weeks

Bestellnummer Part number	w	s	f	a	r	t _{max a}	D _{a min}	HIS	EG55	TN35
R114.1205.00	0,5	8,3	7,5	12	-	1	12	311090R	Δ	▲
R114.1210.00	1	8,3	7,5	12	-	1,5	12	311090R	▲	▲
R114.1215.00	1,5	8,3	7,5	12	0,2	2,5	12	311090R	▲	▲
R114.1220.00	2	8,3	7,5	12	0,2	3	12	311090R	▲	▲
R114.1225.00	2,5	8,3	7,5	12	0,2	3	12	311090R	▲	▲
R114.1230.00	3	8,3	7,5	12	0,2	3	12	311090R	▲	▲
R114.1220.5.00	2	10,8	7,5	12	0,2	5	12	311090R	▲	▲
R114.1225.5.00	2,5	10,8	7,5	12	0,2	5	12	311090R	▲	▲
R114.1230.6.00	3	11,8	7,5	12	0,2	6	12	311090R	▲	▲
L114.1205.00	0,5	8,3	7,5	12	-	1	12	311090L	Δ	▲
L114.1210.00	1	8,3	7,5	12	-	1,5	12	311090L	▲	▲
L114.1215.00	1,5	8,3	7,5	12	0,2	2,5	12	311090L	▲	▲
L114.1220.00	2	8,3	7,5	12	0,2	3	12	311090L	▲	▲
L114.1225.00	2,5	8,3	7,5	12	0,2	3	12	311090L	▲	▲
L114.1230.00	3	8,3	7,5	12	0,2	3	12	311090L	▲	▲
L114.1220.5.00	2	10,8	7,5	12	0,2	5	12	311090L	▲	▲
L114.1225.5.00	2,5	10,8	7,5	12	0,2	5	12	311090L	▲	▲
L114.1230.6.00	3	11,8	7,5	12	0,2	6	12	311090L	▲	▲

Bearbeitung **HINTER** der Drehmitte!
Machining **BEHIND** centre line

Ausführung R = Spindel linksdrehend! Bei Verwendung der Axialstechplatte Typ 114 mit Klemmhalter Typ B114 verlängern sich die Haltermaße l1 und l2 um 3,0 / 5,5 oder 6,5 mm.

R = rotation anti-clockwise! Using the face grooving insert type 114 on toolholder type B114 the size l1 and l2 will be enlarged by 3,0 / 5,5 or 6,5 mm.

P	●	●
M	○	●
K	○	●
N	-	●
S	-	●
H	-	-

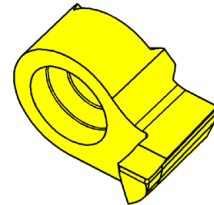
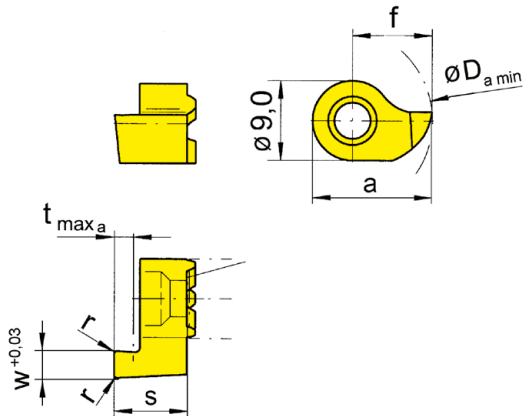
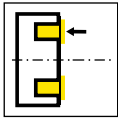

R = rechts wie gezeichnet
R = right hand version shown

L = links spiegelbildlich
L = left hand version

▲ ab Lager
on stock

HM-Sorten
Carbide grades
▲ 4 Wochen
4 weeks

Bestellnummer Part number	w	s	f	a	r	t _{max a}	D _{a min}	HIS	MG12	EG55	TF45	TN35
R114.1410.00	1	8,3	9	13,5	-	1,5	14	311090R	Δ	▲		▲
R114.1415.00	1,5	8,3	9	13,5	0,2	2,5	14	311090R		▲		▲
R114.1420.00	2	8,3	9	13,5	0,2	3	14	311090R		▲		▲
R114.1425.00	2,5	8,3	9	13,5	0,2	3	14	311090R		▲		▲
R114.1430.00	3	8,3	9	13,5	0,2	3	14	311090R	▲	▲		▲
R114.1420.5.00	2	10,8	9	13,5	0,2	5	14	311090R		▲		▲
R114.1425.5.00	2,5	10,8	9	13,5	0,2	5	14	311090R		▲		▲
R114.1430.6.00	3	11,8	9	13,5	0,2	6	14	311090R		▲		▲
L114.1410.00	1	8,3	9	13,5	-	1,5	14	311090L	Δ	▲		▲
L114.1415.00	1,5	8,3	9	13,5	0,2	2,5	14	311090L		▲		▲
L114.1420.00	2	8,3	9	13,5	0,2	3	14	311090L		▲		▲
L114.1425.00	2,5	8,3	9	13,5	0,2	3	14	311090L		▲		▲
L114.1430.00	3	8,3	9	13,5	0,2	3	14	311090L	Δ			▲
L114.1420.5.00	2	10,8	9	13,5	0,2	5	14	311090L		▲		▲
L114.1425.5.00	2,5	10,8	9	13,5	0,2	5	14	311090L		▲		▲
L114.1430.6.00	3	11,8	9	13,5	0,2	6	14	311090L		▲		▲

Bearbeitung **VOR** der Drehmitte!
Machining **IN-FRONT** of centre line

Ausführung R = Spindel rechtsdrehend! Bei Verwendung der Axialstechplatte Typ 114 mit Klemmhalter Typ B114 verlängern sich die Haltermaße l1 und l2 um 3,0 / 5,5 oder 6,5 mm.
R = rotation clockwise! Using the face grooving insert type 114 on toolholder type B114 the size l1 and l2 will be enlarged by 3,0 / 5,5 or 6,5 mm.

P	o	•	•	•
M	-	o	•	•
K	-	o	•	•
N	-	-	•	•
S	-	-	•	•
H	-	-	-	-



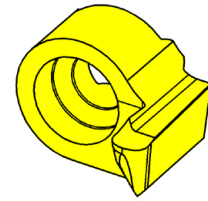
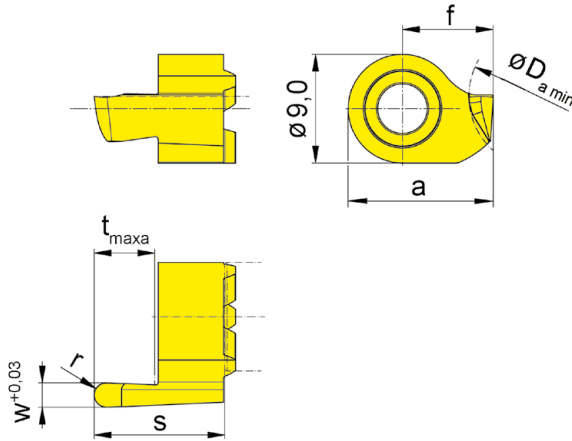
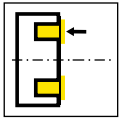

R = rechts wie gezeichnet
R = right hand version shown

L = links spiegelbildlich
L = left hand version

▲ ab Lager
on stock

HM-Sorten
Carbide grades
Δ 4 Wochen
4 weeks

Bestellnummer Part number	w	s	f	a	r	t _{max a}	D _{a min}	HIS	EG55	TN35
R114.1220.5.10	2	10,8	7,5	12	1	5	12	311090R	▲	▲
R114.1225.5.12	2,5	10,8	7,5	12	1,25	5	12	311090R	▲	▲
R114.1230.6.15	3	11,8	7,5	12	1,5	6	12	311090R	▲	▲
L114.1220.5.10	2	10,8	7,5	12	1	5	12	311090L	▲	▲
L114.1225.5.12	2,5	10,8	7,5	12	1,25	5	12	311090L	▲	▲
L114.1230.6.15	3	11,8	7,5	12	1,5	6	12	311090L	▲	▲

Vollradius Bearbeitung **HINTER** der Drehmitte!
Full radius Machining **BEHIND** centre line

Ausführung R = Spindel linksdrehend! Bei Verwendung der Axialstechplatte Typ 114 mit Klemmhalter Typ B114 verlängern sich die Haltermaße l1 und l2 um 5,5 oder 6,5 mm.

R = rotation anti-clockwise! Using the face grooving insert type 114 on toolholder type B114 the size l1 and l2 will be enlarged by 5,5 mm or 6,5 mm.

P	●	●
M	○	●
K	○	●
N	-	●
S	-	●
H	-	-

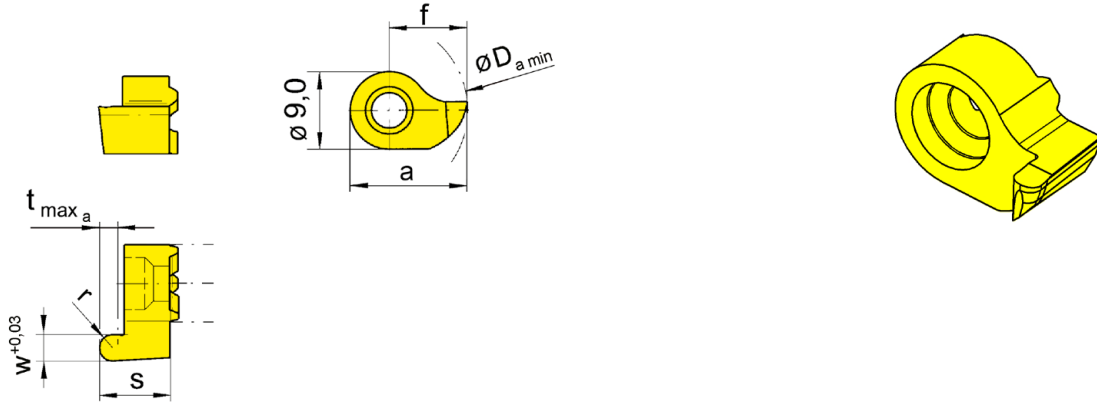
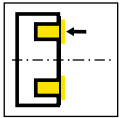

R = rechts wie gezeichnet
R = right hand version shown

L = links spiegelbildlich
L = left hand version

▲ ab Lager
on stock

HM-Sorten
Carbide grades
Δ 4 Wochen
4 weeks

Bestellnummer Part number	w	s	f	a	r	t _{max a}	D _{a min}	HIS	EG55	TN35
R114.1410.05	1	8,3	9	13,5	0,5	1,5	14	311090R	▲	▲
R114.1416.08	1,6	8,3	9	13,5	0,8	2,5	14	311090R	▲	▲
R114.1420.10	2	8,3	9	13,5	1	3	14	311090R	▲	▲
R114.1425.12	2,5	8,3	9	13,5	1,25	3	14	311090R	▲	▲
R114.1430.15	3	8,3	9	13,5	1,5	3	14	311090R	▲	▲
L114.1410.05	1	8,3	9	13,5	0,5	1,5	14	311090L	▲	▲
L114.1416.08	1,6	8,3	9	13,5	0,8	2,5	14	311090L	▲	▲
L114.1420.10	2	8,3	9	13,5	1	3	14	311090L	▲	▲
L114.1425.12	2,5	8,3	9	13,5	1,25	3	14	311090L	▲	▲
L114.1430.15	3	8,3	9	13,5	1,5	3	14	311090L	Δ	▲

Vollradius Bearbeitung **VOR** der Drehmitte!
Full radius Machining **IN-FRONT** of centre line

Ausführung R = Spindel rechtsdrehend! Bei Verwendung der Axialsteckplatte Typ 114 mit Klemhalter Typ B114 verlängern sich die Haltermaße l1 und l2 um 3,0 mm.
R = rotation clockwise! Using the face grooving insert type 114 on toolholder type B114 the size l1 and l2 will be enlarged by 3,0 mm.

R = rotation clockwise! Using the face grooving insert type 114 on toolholder type B114 the size l1 and l2 will be enlarged by 3,0 mm.

P	●	●
M	○	●
K	○	●
N	-	●
S	-	●
H	-	-



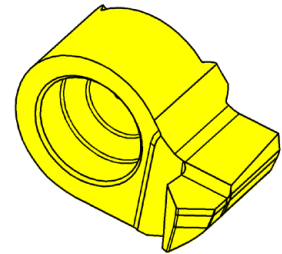
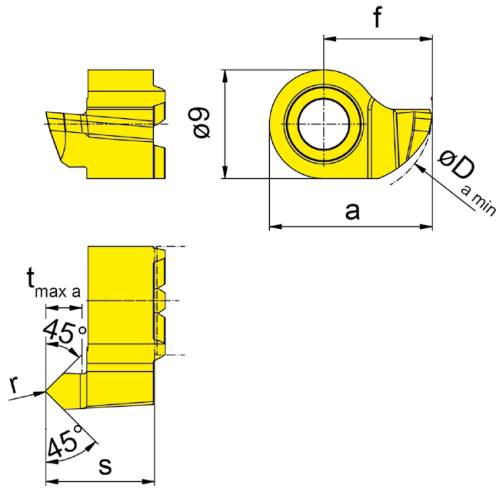
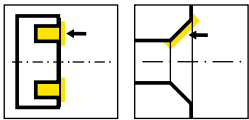

R = rechts wie gezeichnet
R = right hand version shown

L = links spiegelbildlich
L = left hand version

▲ ab Lager
on stock

HM-Sorten
Carbide grades
Δ 4 Wochen
4 weeks

Bestellnummer Part number	s	f	a	r	$t_{\max a}$	$D_{a \min}$	HIS	EG55
R114.4545.14	9	9	13,5	0,1	3	14	311090R	▲
L114.4545.14	9	9	13,5	0,1	3	14	311090L	Δ
								P ●
								M ○
								K ○
								N -
								S -
								H -

Mini



D

- CVD-Dickschicht

- PKD-bestückt

- CBN-bestückt

- CVD-D

- PCD tipped

- PCBN tipped

Schneidplatte
Insert
107/108/111/114
11P/116

PKD
PCD

Seite/Page
277-278, 280-
281, 283-284,
286-289

CVD-D

Seite/Page
279, 282, 285,
290-292

CBN
PCBN

Seite/Page
293-294

D

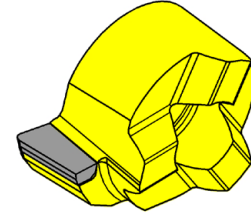
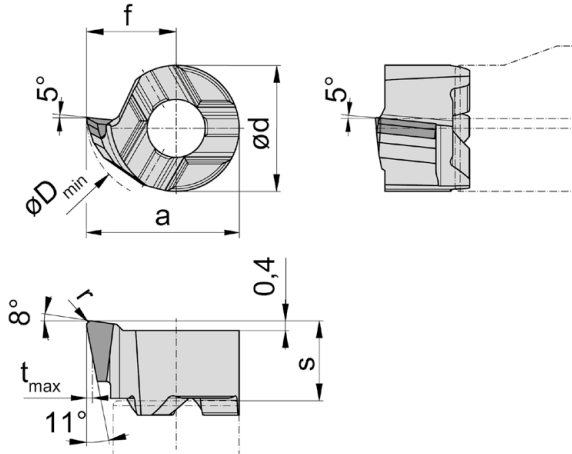
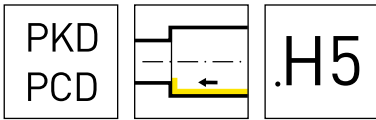

R = rechts wie gezeichnet
R = right hand version shown

▲ ab Lager
on stock

HM-Sorten
Carbide grades
Δ 4 Wochen
4 weeks

Bestellnummer Part number	s	f	a	r	d	t _{max}	D _{min}	HIS	PD75
R107.1002.1.H5.P	3,3	3,7	6,3	0,2	5,2	0,3	6,8	107052R	▲
R107.1004.1.H5.P	3,3	3,7	6,3	0,4	5,2	0,3	6,8	107052R	▲
									P -
									M -
									K -
									N ●
									S -
									H -



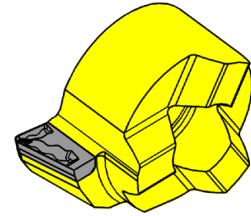
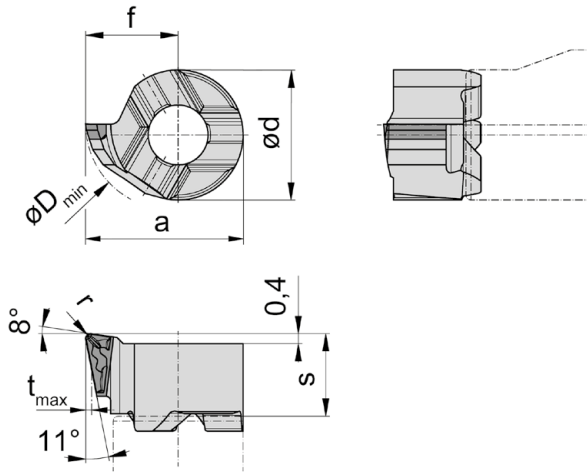
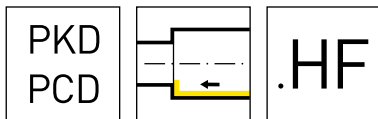

D

R = rechts wie gezeichnet
R = right hand version shown

▲ ab Lager
on stock

HM-Sorten
Carbide grades
Δ 4 Wochen
4 weeks

Bestellnummer Part number	s	f	a	r	d	t _{max}	D _{min}	HIS	PD75
R107.1002.1.HF.P	3,3	3,7	6,3	0,2	5,2	0,3	6,8	107052R	▲
									P -
									M -
									K -
									N ●
									S -
									H -

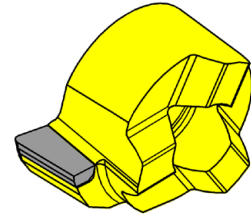
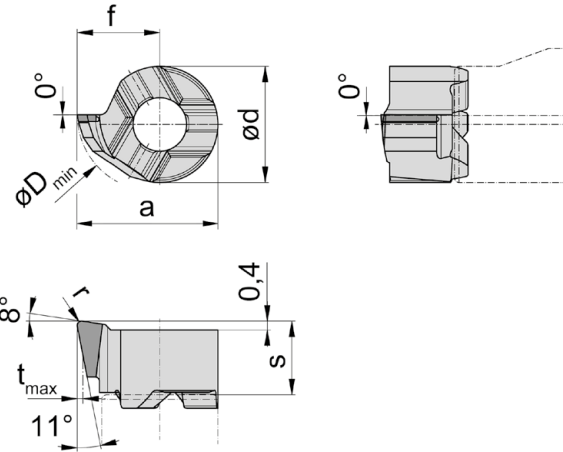
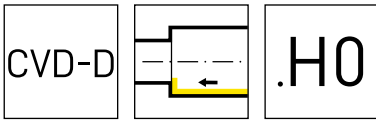

R = rechts wie gezeichnet
R = right hand version shown

▲ ab Lager
on stock

HM-Sorten
Carbide grades
Δ 4 Wochen
4 weeks

Bestellnummer Part number	s	f	a	r	d	t _{max}	D _{min}	HIS	HD03
R107.1002.1.H0.C	3,3	3,7	6,3	0,2	5,2	0,3	6,8	107052R	▲
R107.1004.1.H0.C	3,3	3,7	6,3	0,4	5,2	0,3	6,8	107052R	▲
									P -
									M -
									K -
									N ●
									S -
									H -



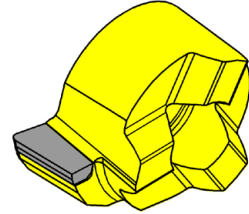
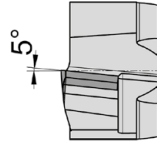
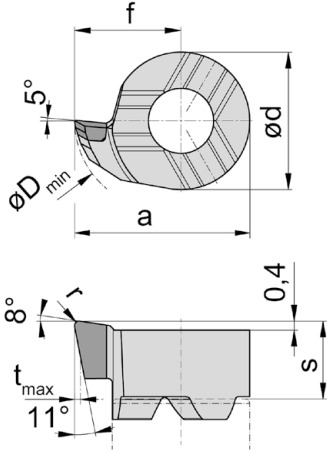
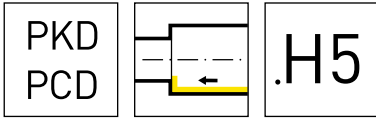

D

R = rechts wie gezeichnet
R = right hand version shown

HM-Sorten
Carbide grades
▲ ab Lager
on stock
Δ 4 Wochen
4 weeks

Bestellnummer Part number	s	f	a	r	d	t _{max}	D _{min}	HIS	PD75
R108.1002.H5.P	3,4	4,65	7,65	0,2	6	0,3	7,8	306060R	▲
R108.1004.H5.P	3,4	4,65	7,65	0,4	6	0,3	7,8	306060R	▲
									P -
									M -
									K -
									N ●
									S -
									H -

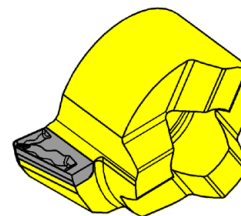
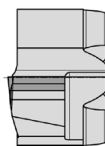
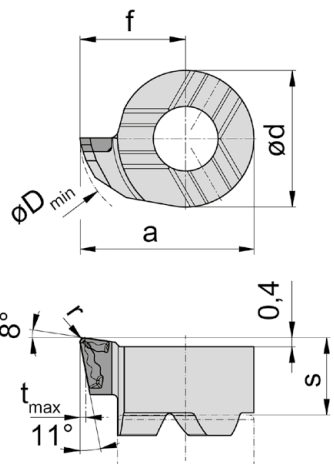
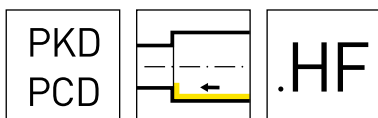

R = rechts wie gezeichnet
R = right hand version shown

▲ ab Lager
on stock

HM-Sorten
Carbide grades
Δ 4 Wochen
4 weeks

Bestellnummer Part number	s	f	a	r	d	t _{max}	D _{min}	HIS	PD75
R108.1002.HF.P	3,4	4,65	7,65	0,2	6	0,3	7,8	306060R	▲
R108.1004.HF.P	3,4	4,65	7,65	0,4	6	0,3	7,8	306060R	▲
									P -
									M -
									K -
									N ●
									S -
									H -

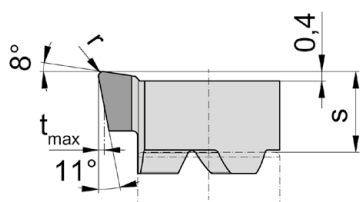
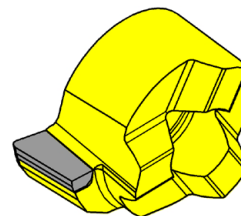
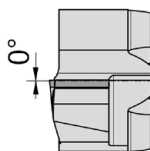
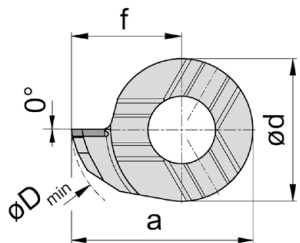
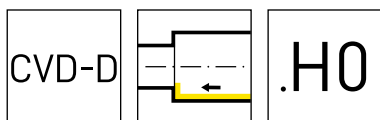

D

R = rechts wie gezeichnet
R = right hand version shown

▲ ab Lager
on stock

HM-Sorten
Carbide grades
Δ 4 Wochen
4 weeks

Bestellnummer Part number	s	f	a	r	d	t _{max}	D _{min}	HIS	HD03
R108.1002.H0.C	3,4	4,65	7,65	0,2	6	0,3	7,8	306060R	▲
R108.1004.H0.C	3,4	4,65	7,65	0,4	6	0,3	7,8	306060R	▲
									P -
									M -
									K -
									N ●
									S -
									H -

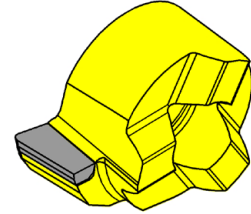
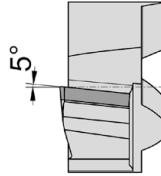
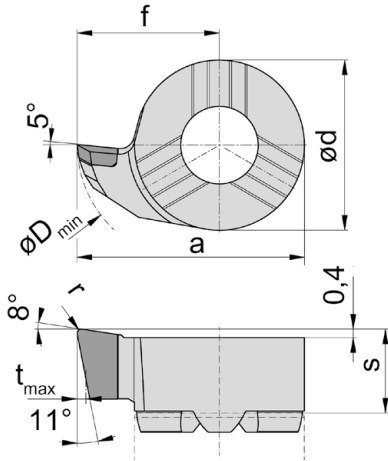
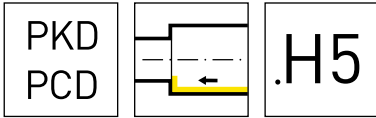

R = rechts wie gezeichnet
R = right hand version shown

▲ ab Lager
on stock

HM-Sorten
Carbide grades
Δ 4 Wochen
4 weeks

Bestellnummer Part number	s	f	a	r	d	t _{max}	D _{min}	HIS	PD75
R111.1002.H5.P	3,95	6,7	10,7	0,2	8	0,4	11	308080R	▲
R111.1004.H5.P	3,95	6,7	10,7	0,4	8	0,4	11	308080R	▲
									P -
									M -
									K -
									N ●
									S -
									H -



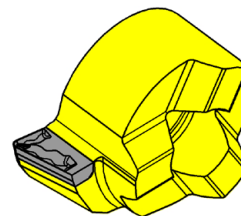
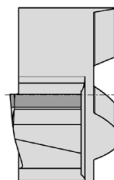
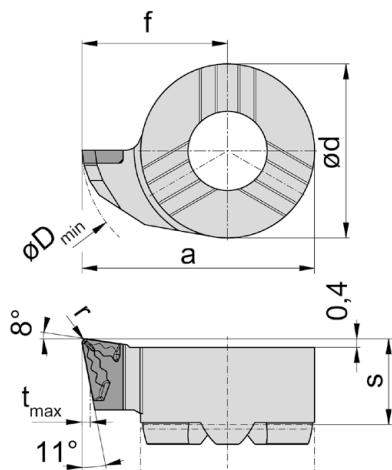
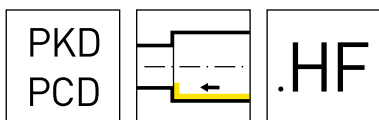

D

R = rechts wie gezeichnet
R = right hand version shown

▲ ab Lager
on stock

HM-Sorten
Carbide grades
Δ 4 Wochen
4 weeks

Bestellnummer Part number	s	f	a	r	d	t _{max}	D _{min}	HIS	PD75
R111.1002.HF.P	3,95	6,7	10,7	0,2	8	0,4	11	308080R	▲
R111.1004.HF.P	3,95	6,7	10,7	0,4	8	0,4	11	308080R	▲
									P -
									M -
									K -
									N ●
									S -
									H -

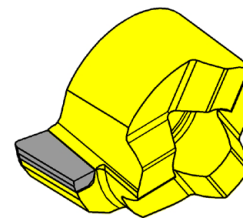
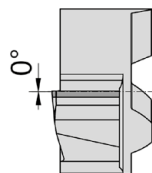
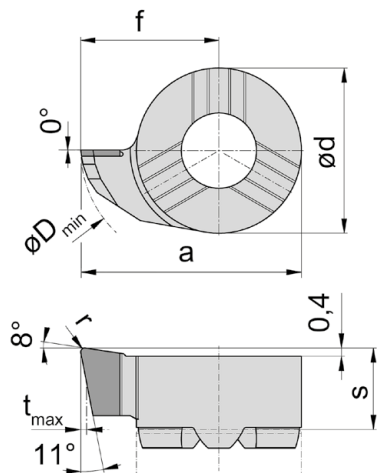
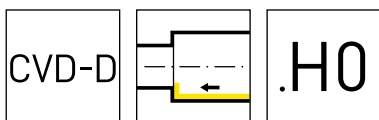

R = rechts wie gezeichnet
R = right hand version shown

▲ ab Lager
on stock

HM-Sorten
Carbide grades
Δ 4 Wochen
4 weeks

Bestellnummer Part number	s	f	a	r	d	t _{max}	D _{min}	HIS	HD03
R111.1002.H0.C	3,95	6,7	10,7	0,2	8	0,4	11	308080R	▲
R111.1004.H0.C	3,95	6,7	10,7	0,4	8	0,4	11	308080R	▲
									P -
									M -
									K -
									N ●
									S -
									H -

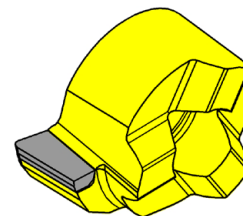
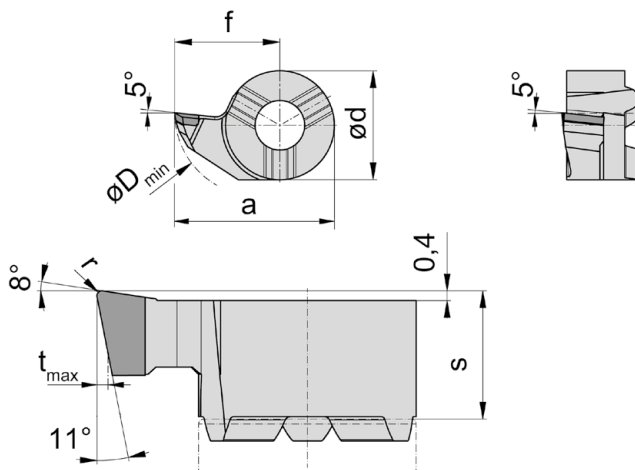
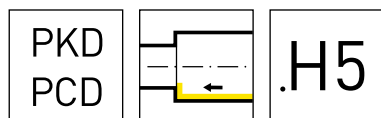

D

R = rechts wie gezeichnet
R = right hand version shown

▲ ab Lager
on stock

HM-Sorten
Carbide grades
Δ 4 Wochen
4 weeks

Bestellnummer Part number	s	f	a	r	d	t _{max}	D _{min}	HIS	PD75
R114.1002.H5.P	5,3	8,7	13,2	0,2	9	0,4	13,8	311090R	▲
R114.1004.H5.P	5,3	8,7	13,2	0,4	9	0,4	13,8	311090R	▲
R114.1008.H5.P	5,3	8,7	13,2	0,8	9	0,4	13,8	311090R	▲
									P -
									M -
									K -
									N ●
									S -
									H -

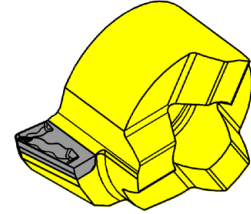
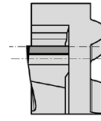
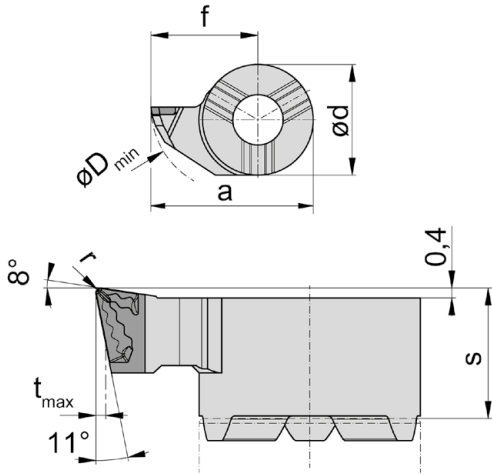
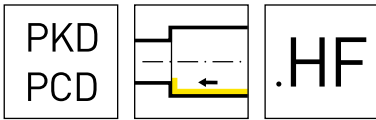

R = rechts wie gezeichnet
R = right hand version shown

▲ ab Lager
on stock

HM-Sorten
Carbide grades
Δ 4 Wochen
4 weeks

Bestellnummer Part number	s	f	a	r	d	t _{max}	D _{min}	HIS	PD75
R114.1002.HF.P	5,3	8,7	13,2	0,2	9	0,4	13,8	311090R	▲
R114.1004.HF.P	5,3	8,7	13,2	0,4	9	0,4	13,8	311090R	▲
R114.1008.HF.P	5,3	8,7	13,2	0,8	9	0,4	13,8	311090R	▲
									P -
									M -
									K -
									N ●
									S -
									H -



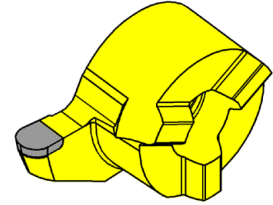
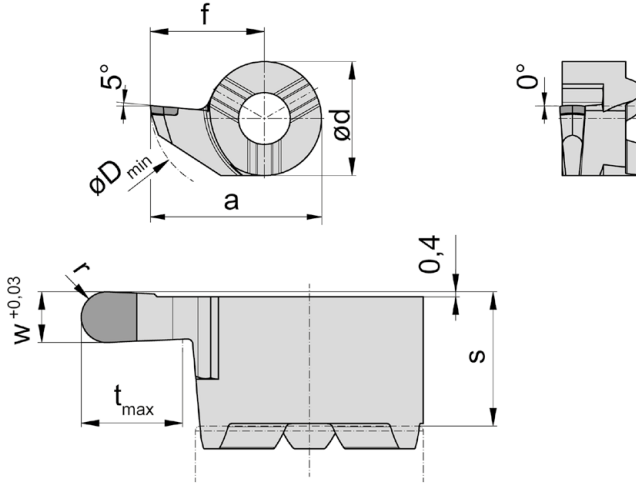
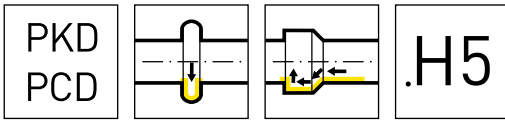

D

R = rechts wie gezeichnet
R = right hand version shown

▲ ab Lager
on stock

HM-Sorten
Carbide grades
Δ 4 Wochen
4 weeks

Bestellnummer Part number	w	s	f	a	r	d	t _{max}	D _{min}	HIS	PD75
R114.VR20.H5.P	2	5,3	9	13,5	1	9	4	14	311090R	▲
R114.VR30.H5.P	3	5,3	9	13,5	1,5	9	4	14	311090R	▲
										P -
										M -
										K -
										N ●
										S -
										H -

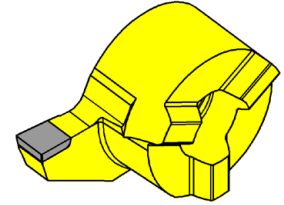
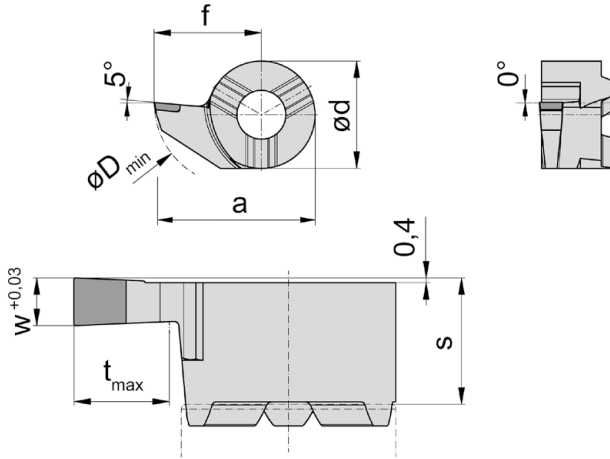
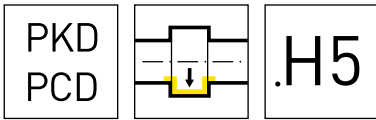

R = rechts wie gezeichnet
R = right hand version shown

HM-Sorten
Carbide grades
▲ ab Lager
on stock
Δ 4 Wochen
4 weeks

Bestellnummer Part number	w	s	f	a	d	t _{max}	D _{min}	HIS	PD75
R114.0100.H5.P	1	5,3	9	13,5	9	4	14	311090R	▲
R114.0200.H5.P	2	5,3	9	13,5	9	4	14	311090R	▲
R114.0300.H5.P	3	5,3	9	13,5	9	4	14	311090R	▲
									P -
									M -
									K -
									N ●
									S -
									H -



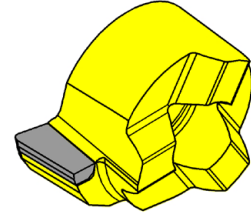
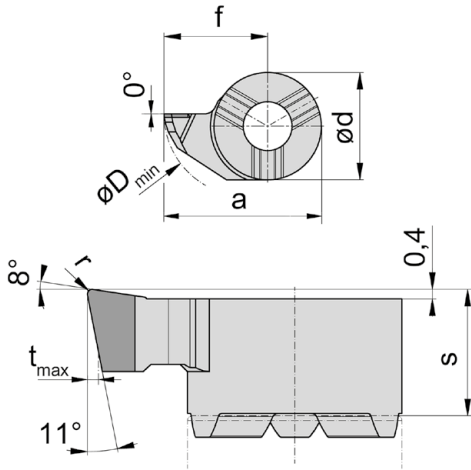
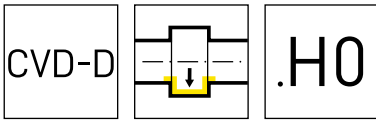

D

R = rechts wie gezeichnet
R = right hand version shown

HM-Sorten
Carbide grades
▲ ab Lager
on stock
Δ 4 Wochen
4 weeks

Bestellnummer Part number	s	f	a	r	d	t _{max}	D _{min}	HIS	HD03
R114.1002.H0.C	5,3	8,7	13,2	0,2	9	0,4	13,8	311090R	▲
R114.1004.H0.C	5,3	8,7	13,2	0,4	9	0,4	13,8	311090R	▲
R114.1008.H0.C	5,3	8,7	13,2	0,8	9	0,4	13,8	311090R	▲
									P -
									M -
									K -
									N ●
									S -
									H -

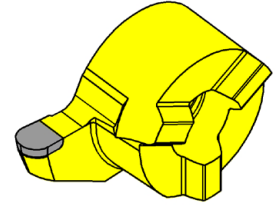
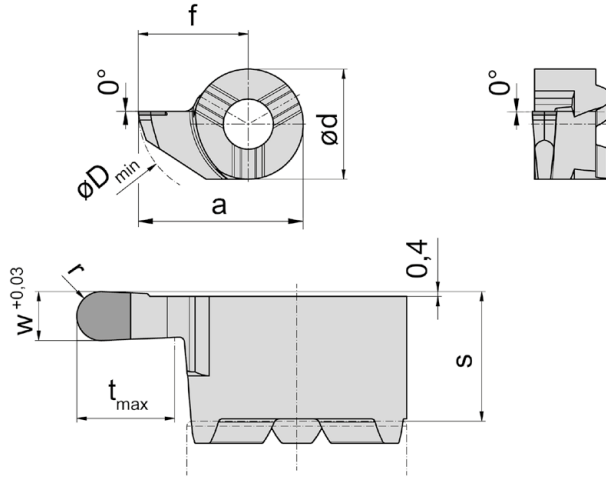
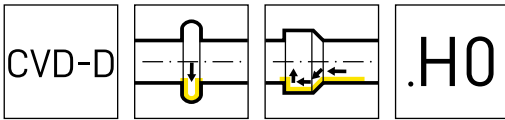

R = rechts wie gezeichnet
R = right hand version shown

▲ ab Lager
on stock

HM-Sorten
Carbide grades
Δ 4 Wochen
4 weeks

Bestellnummer Part number	w	s	f	a	r	d	t _{max}	D _{min}	HIS	HD03
R114.VR20.H0.C	2	5,3	9	13,5	1	9	4	14	311090R	▲
R114.VR30.H0.C	3	5,3	9	13,5	1,5	9	4	14	311090R	▲
										P -
										M -
										K -
										N ●
										S -
										H -



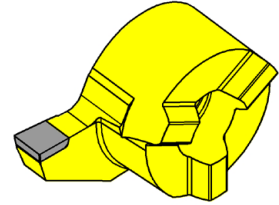
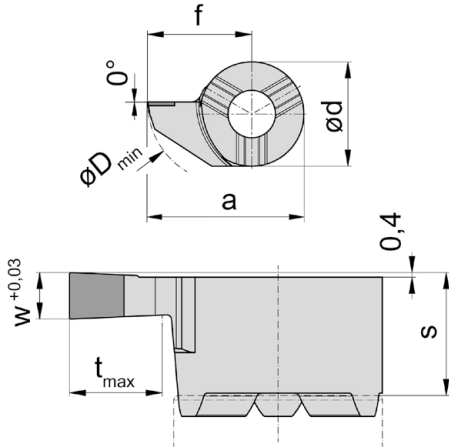
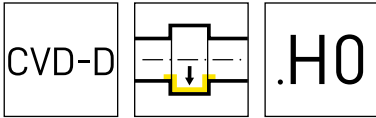

D

R = rechts wie gezeichnet
R = right hand version shown

HM-Sorten
Carbide grades
▲ ab Lager
on stock
Δ 4 Wochen
4 weeks

Bestellnummer Part number	w	s	f	a	d	t _{max}	D _{min}	HIS	HD03
R114.0100.H0.C	1	5,3	9	13,5	9	4	14	311090R	▲
R114.0200.H0.C	2	5,3	9	13,5	9	4	14	311090R	▲
R114.0300.H0.C	3	5,3	9	13,5	9	4	14	311090R	▲
									P -
									M -
									K -
									N ●
									S -
									H -

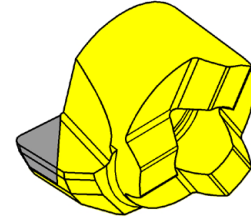
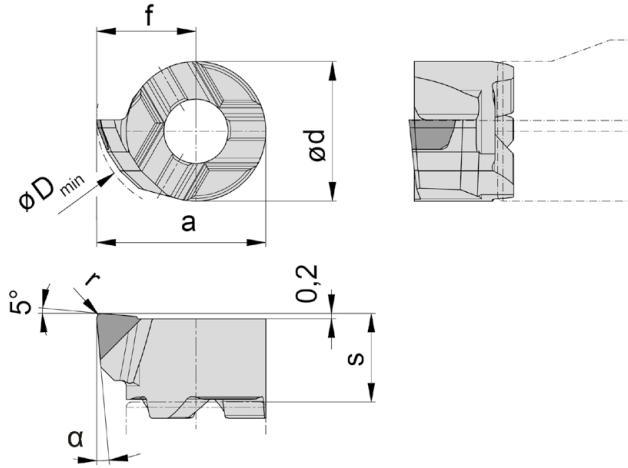
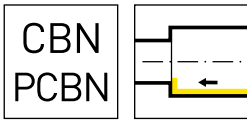

ISO Mat. Code



R = rechts wie gezeichnet
R = right hand version shown

L = links spiegelbildlich
L = left hand version

▲ ab Lager
on stock

HM-Sorten
Carbide grades
Δ 4 Wochen
4 weeks

Bestellnummer Part number	s	f	a	r	d	D _{min}	α	HIS	CB10	CB35
R107.0537.02.B	3,3	3,7	6,3	0,2	5,2	6,8	5°	107052R	▲	
R107.1837.01.B	3,3	3,7	6,3	0,1	5,2	6,8	18°	107052R	▲	▲
R107.1837.02.B	3,3	3,7	6,3	0,2	5,2	6,8	18°	107052R	▲	▲
R108.0547.03.B	3,5	4,65	7,65	0,3	6	7,8	5°	306060R	▲	
R108.1847.03.B	3,5	4,65	7,65	0,3	6	7,8	18°	306060R	▲	▲
R108.1847.15.B	3,5	4,65	7,65	0,15	6	7,8	18°	306060R	▲	▲
R11P.1859.03.B	4,2	5,9	9,4	0,3	7	9,8	18°	11P070R	▲	▲
R11P.1859.15.B	4,2	5,9	9,4	0,15	7	9,8	18°	11P070R	▲	▲
R111.0557.03.B	3,95	5,7	9,7	0,3	8	10	5°	308080R	▲	
R111.0567.03.B	3,95	6,7	10,7	0,3	8	11	5°	308080R	▲	
R114.0572.04.B	5,3	7,25	11,75	0,4	9	12,5	5°	311090R	▲	
R114.1872.02.B	5,3	7,25	11,75	0,2	9	12,5	18°	311090R	▲	▲
R114.1872.04.B	5,3	7,25	11,75	0,4	9	12,5	18°	311090R	▲	▲
R116.0582.04.B	5,3	8,2	13,7	0,4	11	14	5°	116110R	▲	
L107.1837.01.B	3,3	3,7	6,3	0,1	5,2	6,8	18°	107052L	Δ	Δ
L107.1837.02.B	3,3	3,7	6,3	0,2	5,2	6,8	18°	107052L	Δ	Δ
L108.1847.03.B	3,5	4,65	7,65	0,3	6	7,8	18°	306060L	Δ	Δ
L108.1847.15.B	3,5	4,65	7,65	0,15	6	7,8	18°	306060L	Δ	Δ
L11P.1859.03.B	4,2	5,9	9,4	0,3	7	9,8	18°	11P070L	Δ	
L11P.1859.15.B	4,2	5,9	9,4	0,15	7	9,8	18°	11P070L	Δ	Δ
L114.1872.02.B	5,3	7,25	11,75	0,2	9	12,5	18°	311090L	▲	▲
L114.1872.04.B	5,3	7,25	11,75	0,4	9	12,5	18°	311090L	▲	▲



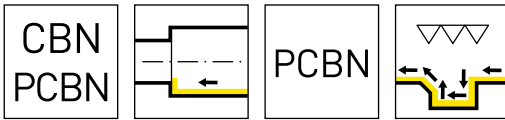

D

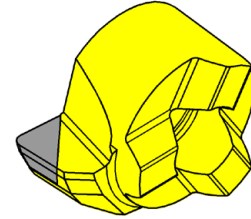
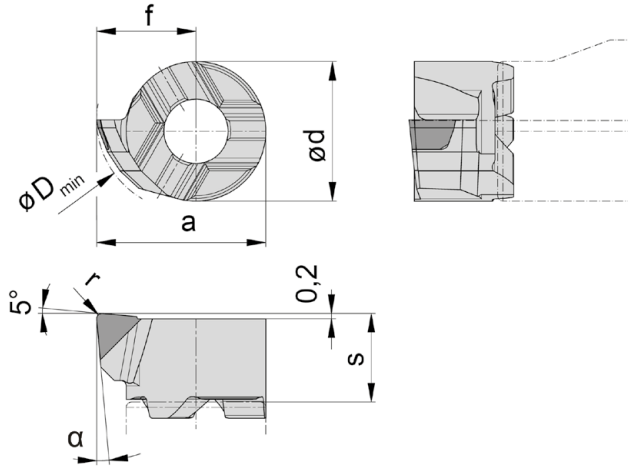

ISO Mat. Code



R = rechts wie gezeichnet
R = right hand version shown

L = links spiegelbildlich
L = left hand version

▲ ab Lager
on stock

HM-Sorten
Carbide grades
Δ 4 Wochen
4 weeks

Bestellnummer Part number	s	f	a	r	d	D _{min}	α	HIS	CH1G
R107.1837.01.BA	3,3	3,7	6,3	0,1	5,2	6,8	18°	107052R	▲
R107.1837.02.BA	3,3	3,7	6,3	0,2	5,2	6,8	18°	107052R	▲
R108.1847.03.BA	3,5	4,65	7,65	0,3	6	7,8	18°	306060R	▲
R108.1847.15.BA	3,5	4,65	7,65	0,15	6	7,8	18°	306060R	▲
R11P.1859.03.BA	4,2	5,9	9,4	0,3	7	9,8	18°	11P070R	▲
R11P.1859.15.BA	4,2	5,9	9,4	0,15	7	9,8	18°	11P070R	▲
R114.1872.02.BA	5,3	7,25	11,75	0,2	9	12,5	18°	311090R	▲
R114.1872.04.BA	5,3	7,25	11,75	0,4	9	12,5	18°	311090R	▲
L107.1837.01.BA	3,3	3,7	6,3	0,1	5,2	6,8	18°	107052L	Δ
L107.1837.02.BA	3,3	3,7	6,3	0,2	5,2	6,8	18°	107052L	Δ
L108.1847.03.BA	3,5	4,65	7,65	0,3	6	7,8	18°	306060L	Δ
L108.1847.15.BA	3,5	4,65	7,65	0,15	6	7,8	18°	306060L	Δ
L11P.1859.03.BA	4,2	5,9	9,4	0,3	7	9,8	18°	11P070L	Δ
L11P.1859.15.BA	4,2	5,9	9,4	0,15	7	9,8	18°	11P070L	Δ
L114.1872.02.BA	5,3	7,25	11,75	0,2	9	12,5	18°	311090L	▲
L114.1872.04.BA	5,3	7,25	11,75	0,4	9	12,5	18°	311090L	▲

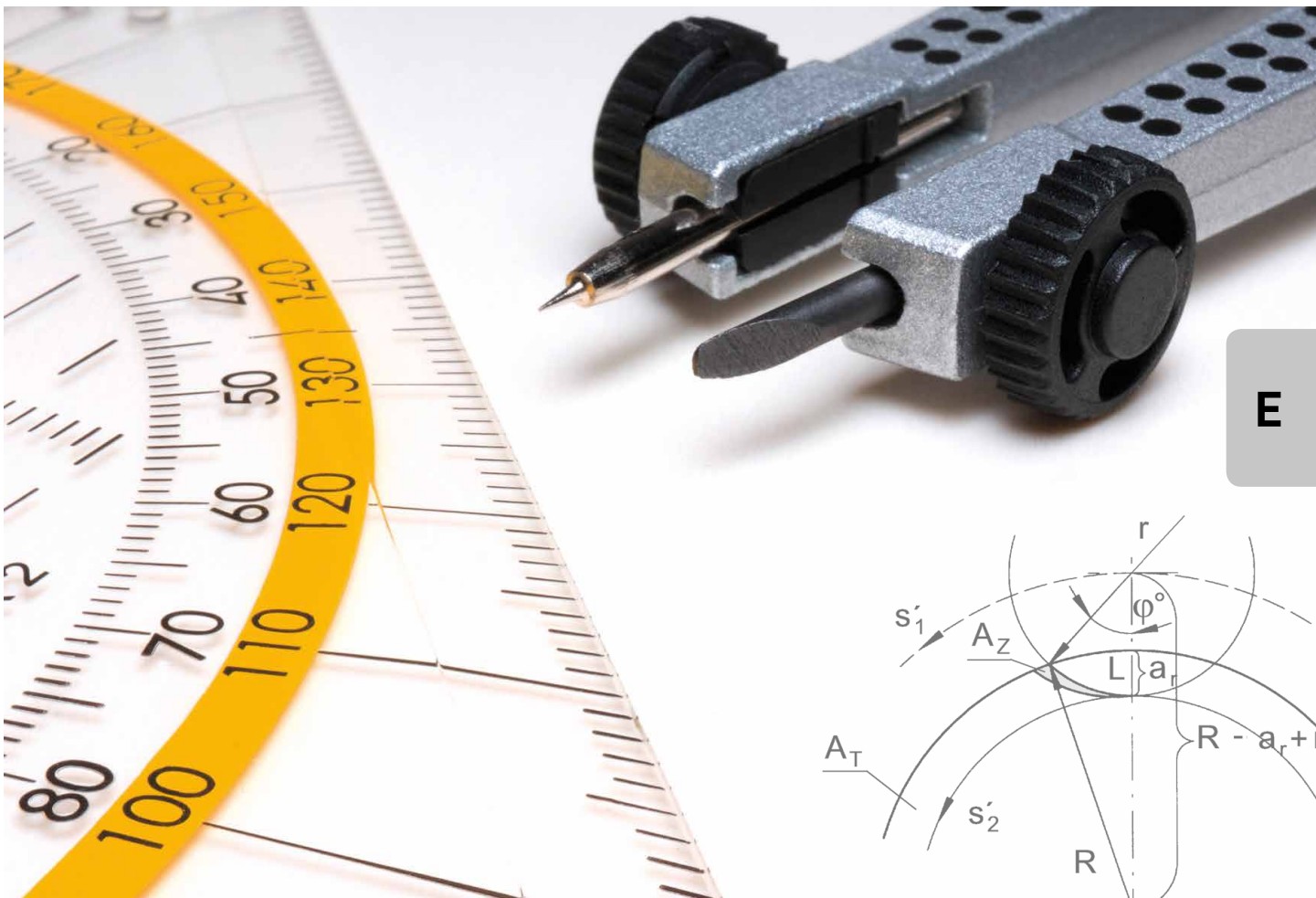

Inhalt/Summary

Seite/Page

Beschichtungsübersicht

296-297

Coating Overview

Schnitttdaten und Geometrien

298-305

Cutting Data and Geometries

**Technische Informationen
Gewindedrehen**

306-307

Technical Information Threading

**Schnitttdaten Hochharte
Schneidstoffe**

308-310

Cutting Data Ultra-Hard
Cutting Material

Anzugsmomente

311

Torque of Screws

Beschichtungsübersicht

Coating Overview



E

Schneidstoff Material group	Schichtaufbau Coating structure	Empfehlung Recommendation						Anwendung Application
		P05	M05	K05	N05	S05	H05	
TH3_	TiAlN	P10	M10	K10	N10	S10	H10	Für mittlere Vorschübe, auch geeignet bei Schnittunterbrechungen For medium feeds, also suitable for interrupted cuts
		P20	M20	K20	N20	S20	H20	
		P30	M30	K30	N30	S30	H30	
		P40	M40	K40	N40			
		P50	M50					
EG3_	AlTiN + TiN	P05	M05	K05	N05	S05	H05	Für kleine bis mittlere Vorschübe, zum Schlichten ohne Schnittunterbrechung For small to medium feeds, for finishing without any interruption of the cut
		P10	M10	K10	N10	S10	H10	
		P20	M20	K20	N20	S20	H20	
		P30	M30	K30	N30	S30	H30	
		P40	M40	K40	N40			
		P50	M50					
EG5_	AlTiN + TiN	P05	M05	K05	N05	S05	H05	Für mittlere Vorschübe, auch geeignet bei Schnittunterbrechungen For medium feeds, also suitable for interrupted cuts
		P10	M10	K10	N10	S10	H10	
		P20	M20	K20	N20	S20	H20	
		P30	M30	K30	N30	S30	H30	
		P40	M40	K40	N40			
		P50	M50					
ES1_	AlTiN	P05	M05	K05	N05	S05	H05	Für Feinstbearbeitungen und kleine Vorschübe, zum Schlichten ohne Schnittunterbrechung For superfinishing and small feeds, for finishing without interrupting the cut
		P10	M10	K10	N10	S10	H10	
		P20	M20	K20	N20	S20	H20	
		P30	M30	K30	N30	S30	H30	
		P40	M40	K40	N40			
		P50	M50					
IG3_	TiAlSiN	P05	M05	K05	N05	S05	H05	Für hohe Schnittgeschwindigkeiten ohne Schnittunterbrechung For high cutting speeds without any interruption of the cut
		P10	M10	K10	N10	S10	H10	
		P20	M20	K20	N20	S20	H20	
		P30	M30	K30	N30	S30	H30	
		P40	M40	K40	N40			
		P50	M50					

Beschichtungsübersicht

Coating Overview



Schneidstoff Material group	Schichtaufbau Coating structure	Empfehlung Recommendation						Anwendung Application
		P05	M05	K05	N05	S05	H05	
SG3_	TiAlCrSiN	P10	M10	K10	N10	S10	H10	Für kleine bis mittlere Vorschübe, zum Schlichten ohne Schnittunterbrechung
		P20	M20	K20	N20	S20	H20	
		P30	M30	K30	N30	S30	H30	For small to medium feeds, for finishing without any interruption of the cut
		P40	M40	K40	N40			
		P50	M50					
TI2_	TiCN	P05	M05	K05	N05	S05	H05	Für kleine bis mittlere Vorschübe bei niedrigen Schnittgeschwindigkeiten, Reduzierung von Aufbauschnitten
		P10	M10	K10	N10	S10	H10	
		P20	M20	K20	N20	S20	H20	For small to medium feeds at low low cutting speeds, Reduction of built-up edges
		P30	M30	K30	N30	S30	H30	
		P40	M40	K40	N40			
		P50	M50					
TN3_	TiN	P05	M05	K05	N05	S05	H05	Für niedrige Schnittgeschwindigkeiten, geeignet bei Schnittunterbrechungen
		P10	M10	K10	N10	S10	H10	
		P20	M20	K20	N20	S20	H20	For low cutting speeds, Suitable for cutting interruptions
		P30	M30	K30	N30	S30	H30	
		P40	M40	K40	N40			
		P50	M50					



ISO 513		P	M	K	N	S	H
+ Zähigkeit / Tenacity - Verschleißfestigkeit / Wear resistance +	05	05	05	05	05	05	05
	10	10	10	10	10	10	10
	20	20	20	20	20	20	20
	30	30	30	30	30	30	30
	40	40	40	40	40		
	50	50					

E

Werkstoff Material		Materialgruppe Material group	Härte (HB) Hardness Brinell	Zugfestigkeit R_m [N/mm ²] Tensile Strength	Beispiel Werkstoff Example Material	
P	unlegierter Stahl Carbon steel	~ 0,2 % C	P1.1	125	430	CK15
		~ 0,4% C geglüht annealed	P1.2	190	610	19Mn6
		~ 0,4% C vergütet quenched	P1.3	210	640	36Mn5
		~ 0,6% C geglüht annealed	P1.4	190	610	C55
		~ 0,6% C vergütet quenched	P1.5	300	1000	CK60
		Automatenstahl Free cutting steel	P1.6	220	750	9SMn28
	niedrig legierter Stahl (<5%) Alloyed steel	geglüht annealed	P2.1	180	590	100Cr6
		vergütet quenched	P2.2	280	960	14NiCr10
		vergütet quenched	P2.3	350	1250	34CrMo4
		vergütet quenched	P2.4	430	1450	55Cr3
	hochlegierter Stahl (>5%) high alloyed steel	geglüht annealed	P3.1	200	680	X10CrAl18
		gehärtet hardened	P3.2	350	1200	X210Cr2
	Stahlguss Cast steel	unlegiert unalloyed	P4.1	180	590	GE200
		legiert alloyed	P4.2	220	750	GX40CrSi28
	Sinterstahl Sintered steel	weich soft	P5.1	220	570	Sint-D39
	M	Rostfreier Stahl Stainless steel	martensitisch ferritisch martensitic ferritic	M1.1	200	680
austenitisch austenitic			M1.2	300	1000	X6CrNiMo- Ti17-12-2
austenitisch ferritisch austenitic ferritic			M1.3	230	780	X2CrNi- Mo-N17-13-3
H	Gehärtete Stähle Hardened steels	50-55 HRC	H1.1	-	-	
		55-60 HRC	H1.2	-	-	
		60-63 HRC	H1.3	-	-	
		> 63HRC	H1.4	-	-	

Schnittgeschwindigkeit vc (m/min) / Startwerte Cutting speed vc (m/min) / Start values									
	MG12	TN3_	TI2_	TH3_ TF4_	AN2_ RC2_	EG3_ EG5_	IG3_	DD2_	SG3_
	120-16	180 - 16	180 - 16	210 - 16	210 - 16	200 - 16	230-16		230-16
	110-16	170-16	170-16	200-16	200-16	200-16	230-16		230-16
	110-16	160-16	160-16	190-16	190-16	190-16	220-16		220-16
	110-16	150-16	150-16	180-16	180-16	180-16	210-16		210-16
	100-16	120-16	140-16	170-16	170-16	170-16	200-16		200-16
	120-16	160-16	160-16	190-16	190-16	190-16	220-16		220-16
	90 - 16	150 - 16	150 - 16	180-16	180-16	180 - 16	210-16		210-160
	85-16	140-16	140-16	180-16	180-16	180 - 16	210-160		210-160
	80-16	140-16	140-16	180-16	180-16	180 - 16	210-16		210-16
	80-16	140-16	140-16	160-16	160-16	160-16	180-16		180-16
	90-16	90 - 16	90 - 16	140 - 16	140 - 16	120 - 16	140-16		140-16
									140-16
	110-16	180 - 16	180 - 16	180 - 16	180 - 16	160 - 16	180-16		180-16
	70-16	170-16		180 - 16	180 - 16	160 - 16	180-16		180-16
		90 - 16		90 - 19	90 - 16	90 - 16	100 - 15		100 - 16
		80 - 16		80 - 16	80 - 16	80 - 16	80 - 16		40 - 16
		60-16		60-16	60-16	60-16	70-16		80-16
							50 - 16		60 - 16
							50 - 16		60 - 16

E

E

Werkstoff Material		Materialgruppe Material group	Härte (HB) Hardness Brinell	Zugfestigkeit R_m [N/mm ²] Tensile Strength	Beispiel Werkstoff Example Material	
K Grauguss Grey cast iron	niedrige Festigkeit low tensile strength	K1.1	180	250	GG-25	
	hohe Festigkeit high tensile strength	K1.2	250	350	GG-40	
	Kugelgraphitguss Spheroidal graphite cast iron	ferritisch ferritic	K2.1	160	400	GGG-40
		perlitisches perlitic	K2.2	260	700	GGG-60
	Temperguss Malleable cast iron	ferritisch ferritic	K3.1	200	400	GTW-45
		perlitisches perlitic	K3.2	260	700	GTS-55-04
	Ausferritisches Gusseisen/ADI Ausferritic spheroidal cast iron / ADI	vergütet quenched	K4.1	260	800	
		vergütet quenched	K4.2	350	1050	
		vergütet quenched	K4.3	450	1400	
N Al-Legierungen Al-alloys	nicht vergütbar not heat treatable	N1.1	30		AlMg1	
	vergütbar heat treatable	N1.2	100	340	AlMgSi1	
	Al-Guss- Legierung Al-cast-alloy	< 6% Si	N2.1	80	300	AlMgSi6
		6-10% Si	N2.2	100	320	AlSi7Mg
		10-15 % Si	N2.3	130	450	AlSi12
	Kupfer- Legierungen Copper-alloys	Reinkupfer Pure copper	N3.1	100	340	Cu
		Messing, Bronze Brass	N3.2	90	310	CuZn40Pb
		Messing bleifrei Lead-free brass	N3.3	110	430	CuZn40
		hochfest high strength	N3.4	300	1000	CuZ- n25Al5-Mn4Fe3
	Graphit Graphite	N4.1				
S Warmfeste Legierung (Fe) Heat resistant alloy	geglüht annealed	S1.1	200	670		
	gehärtet hardened	S1.2	275	930		
	Warmfeste Legierung (Ni, Co) Heat resistant alloy	geglüht annealed	S2.1	250	840	Inconel 600
		gehärtet hardened	S2.2	350	1200	Inconel 713

Schnittgeschwindigkeit vc (m/min) / Startwerte Cutting speed vc (m/min) / Start values									
MG12	TN3_	TI2_	TH3_ TF4_	AN2_ RC2_	EG3_ EG5_	IG3_	DD2_	SG3_	
90 - 16	150 - 16		160 - 16		160 - 16				
	120 - 16								
90 - 16	130 - 16								
	100-16		160 - 18		140 - 16				
	130 - 16		180 - 16		160 - 18				
220 - 16		220 - 16	220 - 16		220 - 16		350 - 16		
220 - 16		220 - 16	220 - 16		220 - 16		350 - 16		
220 - 16		220 - 16	220 - 16		220 - 16		350 - 16		
							350-16		
220 - 16							300 - 16		
220 - 16							300 - 16		
220 - 16							250 - 16		
180 - 16							200 - 16		
50-16						75-16		75 - 16	
50-16									
30-16						40 - 16		40 - 16	
30-16						40 - 16		40 - 16	

E

Schnittdaten

Cutting Data



Werkstoff Material		Materialgruppe Material group	Härte (HB) Hardness Brinell	Zugfestigkeit R _m [N/mm ²] Tensile Strength	Beispiel Werkstoff Example Material	
S	Titan	Titanlegierung α Titanium alloy α	S3.1	120	240	Ti99,7
		Titanlegierung α-β Titanium alloy α-β	S3.2	360	1200	Ti6Al4V
		Titanlegierung β Titanium alloy β	S3.3	410	1400	Ti-10V-2Fe-3Al
O	Thermoplaste Thermoplastics		01.1			
	Duroplaste Duro plaste		01.2			
	Kunststoffe glas- faserverstärkt Plastics glass fibre reinforced	GFK	01.3			
	Kunststoffe kohle- faserverstärkt Plastics carbon fibre reinforced	CKF	01.4			

E

Schnittgeschwindigkeit vc (m/min) / Startwerte Cutting speed vc (m/min) / Start values									
	MG12	TN3_	TI2_	TH3_ TF4_	AN2_ RC2_	EG3_ EG5_	IG3_	DD2_	SG3_
	30-16						75 - 16		85-16
	30-16						75 - 16		85-16
	30-16						75-16		85-16
	150 - 16								
	150 - 16								
	150 - 16								
	300 - 16								

E

Schnittdaten R/L105.B0...

Cutting data R/L105.B0...



E

Ausdrehen Stahl Boring Steel		Schnitttiefe ap (mm) Depth of cut ap (mm)					
		0,5	1	1,5	2	2,5	3
		Vorschub f [mm/U] Feed rate f [mm/rev]					
R/L105.B0.30.20.045.1	1,5*D	0,03-0,05	0,02-0,03				
R/L105.B0.30.20.075.1	2,5*D	0,03-0,05	0,02-0,03				
R/L105.B0.40.20.060.1	1,5*D	0,04-0,06	0,04-0,06	0,04-0,06			
R/L105.B0.40.20.100.1	2,5*D	0,04-0,06	0,04-0,06	0,04-0,06			
R/L105.B0.50.20.075.1	1,5*D	0,05-0,08	0,05-0,08	0,04-0,07	0,04-0,07		
R/L105.B0.50.20.125.1	2,5*D	0,05-0,08	0,05-0,08	0,04-0,07	0,04-0,07		
R/L105.B0.60.20.090.1	1,5*D	0,07-0,1	0,07-0,1	0,07-0,1	0,07-0,1	0,05-0,08	
R/L105.B0.60.20.150.1	2,5*D	0,07-0,1	0,07-0,1	0,07-0,1	0,07-0,1	0,05-0,08	
R/L105.B0.70.20.105.1	1,5*D	0,08-0,1	0,07-0,1	0,07-0,1	0,07-0,1	0,07-0,08	0,05-0,07
R/L105.B0.70.20.175.1	2,5*D	0,08-0,1	0,07-0,1	0,07-0,1	0,07-0,1	0,07-0,08	0,05-0,07

Vorschubwerte für rostfreie Materialien: Minimal-Werte wählen.

Feed rates for stainless materials: Select minimum values.

Bohren Stahl Drilling Steel		Vorschub f [mm/U] Feed rate f [mm/rev]
R/L105.B0.30.20.045.2	1,5*D	0,01-0,02
R/L105.B0.30.20.075.2	2,5*D	0,01-0,02
R/L105.B0.40.20.060.2	1,5*D	0,01-0,02
R/L105.B0.40.20.100.2	2,5*D	0,01-0,02
R/L105.B0.50.20.075.2	1,5*D	0,02-0,04
R/L105.B0.50.20.125.2	2,5*D	0,02-0,04
R/L105.B0.60.20.090.2	1,5*D	0,03-0,05
R/L105.B0.60.20.150.2	2,5*D	0,03-0,05
R/L105.B0.70.20.105.2	1,5*D	0,03-0,05
R/L105.B0.70.20.175.2	2,5*D	0,03-0,05

Zum Bohren empfehlen wir die Universalgeometrie

For drilling we recommend the universal geometry



R/L105.B0...1

Geometrie mit Spantreppe für bessere Spankontrolle

- Ausdrehen mit großen Zustellungen
- Für allgemeine Stähle
- Mit Schleppschneide für höhere Vorschübe
- Bessere Spankontrolle
- Bohren in allgemeinen Stählen
- Bei problematischen Anwendungen mit dem Ziel Prozesssicherheit
- Auch bei langspanenden Werkstoffen

Geometry with chipbreaker for better chip control

- Turning with large infeeds
- For general steels
- With trailing cutting edge for higher feeds
- Better chip control
- Drilling in general steels
- For problematic applications with the aim of process reliability
- Also for long-chipping materials

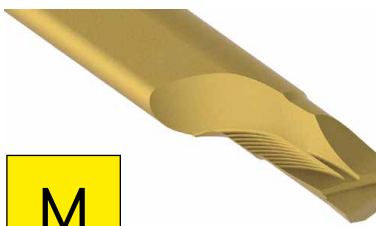

R/L105.B0...2

Universalgeometrie

- Ausdrehen mit großen Zustellungen
- Leichtschneidende Universalgeometrie auch für rostfreie Stähle
- Mit Schleppschneide für höhere Vorschübe
- Weniger Schnittdruck, auch für dünnwandige Bauteile
- Zum Bohren in Stahl und NE-Metallen

Universal geometry

- Turning with large infeeds
- Easy cutting universal geometry also for stainless steels
- With trailing cutting edge for higher feeds
- Less cutting pressure, suitable even for thin-walled components
- For drilling in steel and non-ferrous metals

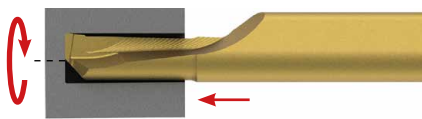

Bohren ins Volle mit ebenem Bohrungsgrund
Drilling into the solid and achieving a flat hole bottom



Drehen von Plankonturen
Turning of face profiles

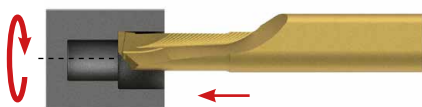

Drehen von Innenkonturen
Turning of internal profiles

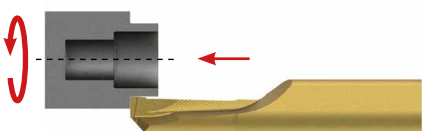

Drehen von Außenkonturen
Turning of external profiles

V _{max} m/min	Stahl (Nmm ² Festigkeit) Steel (N/mm ² Tensile strength)					rostfr. Stahl Stainless steel	Grauguss Grey cast iron	Al
	400-500	500-700	700-850	850-1150	> 1150			
	160	140	120	90	70	90	100	300

Steigung Pitch		Anzahl der Schnitte Number of passes							
mm	Gg/'' tpi	Stahl (Nmm ² Festigkeit) Steel (N/mm ² Tensile strength)					rostfr. Stahl Stainless steel	Grauguss Grey cast iron	Al
		400-500	500-700	700-850	850-1150	> 1150			
0,8	32	10	10	12	12	14	14	12	10
1,0	24	13	13	15	15	18	18	15	13
1,25	20-19	16	16	19	19	22	22	19	16
1,5	16	20	20	23	23	27	27	23	20
1,75	14	23	23	27	27	31	31	27	23
2,0	12-11	27	27	30	30	36	36	30	27
2,5	10	33	33	38	38	45	45	38	33
3,0-3,5	8	40	40	46	46	54	54	46	40

Die Anzahl der Durchgänge für das Gewindedrehen in o.g. Tabelle sind nur Richtwerte.

Folgendes ist zu beachten:

- Beim 1. Durchgang darf die Zustellung nicht zu groß sein, um Ausbrüche an der Schneide zu vermeiden.
- Leerschnitte (ohne Zustellung) sind in der Tabelle nicht berücksichtigt.

The recommended number of passes in the above table are approximate figures.

Please note:

- to avoid breakages at the cutting edge, the depth of cut at the first pass should not be too deep
- finishing passes (with zero depth of cut) are not considered in the table

Vorschubsrichtung Innengewindedrehen

Feed direction internal threading

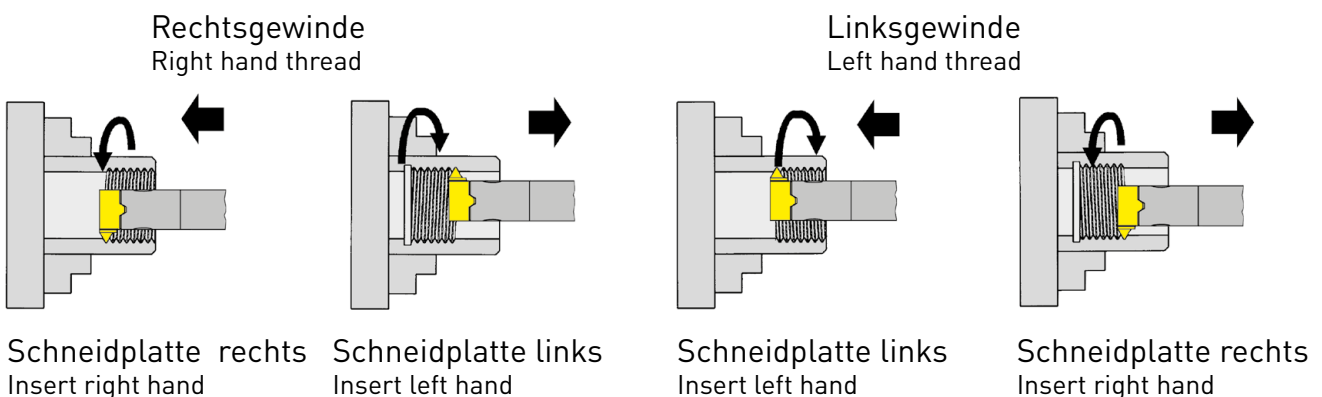

Zustellung In-Feed

Radiale Zustellung

Die gebräuchlichste Methode Gewinde herzustellen. Beide Schneiden sind gleichzeitig im Eingriff.

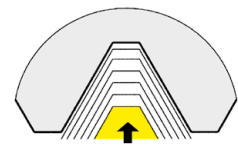

Radial In-Feed

Metal removed on both sides of the insert simultaneously. The most commonly used method for thread production.

Modifizierte Flankenzustellung

Weniger Verschleiß der Schleppschnaide und eine bessere Oberflächengüte der entsprechenden Gewindeflanke.



Modified flank in-feed

Less wear of the trailing edge and better surface finish on corresponding flank.

Wechselnde Flankenzustellung

Beide Schneidflanken werden gleichmäßig benutzt, ergibt höhere Standzeiten.



Alternating flank in-feed

Both edges are being fully utilized which means longer tool life.

Einseitige Flankenzustellung

Geringerer Schnittdruck und bessere Wärmeabfuhr.



Flank in-feed

More easily formed chip and better heat dissipation.

Werkstoff Material	Ausführung Version	Schnittgeschwindigkeit v_c Cutting speed v_c		Empfohlene Kühlung Recommended Coolant
		min	max	
Al-Knetlegierungen Al-wrought alloys	.HF	150	4500	Emulsion Emulsion
untereutektisches Aluminium Aluminium alloys up to 12% Si content	.HF	100	3500	Emulsion Emulsion
übereutektisches Aluminium Aluminium alloys with 12-20% Si content	.HF	80	1500	Emulsion Emulsion
Magnesium Magnesium	.H5 / .HF	100	4000	Emulsion Emulsion
Kupfer, Bronze, Messing bleifrei Copper, Bronze, Brass without lead	.H5 / .HF	90	1600	Öl Oil
Kupfer OFHC, Wolfram-Kupfer OFHC Copper, Tungsten copper	.H5	50	800	Öl Oil
Zink, Messing (MS58) Zinc, Brass (MS58)	.H5 / .HF	100	1800	Öl Oil
Neusilber, Kupfer-Nickel-Legierungen Nickel silver, Copper-nickel-alloys	.H5	80	450	Emulsion Emulsion
Titan, Molybdän, Platin, Iridium Titanium, Molybdenum, Platin, Iridium	.H5	40	250	Emulsion Emulsion
Graphit Graphite	.H0	50	1000	Luft Air
Hartmetall und Keramik, fertig gesintert Carbide and ceramik, sintered	.H0	25	80	Luft Air
Hartmetall und Keramik, vorgesintert Carbide and ceramik, presintered	.H0	40	100	Luft Air
Kunststoffe, Faserverbundwerkstoffe Synthetics, Reinforced plastics	.H5	120	1700	Luft Air
GFK GFRP	.H5 / .H0	100	500	Luft Air
CFK CFRP	.H5 / .H0	80	300	Luft Air

Weitere Informationen zu Diamantschneidstoffen finden Sie in unserem Katalog:
„HOCHHARTE SCHNEIDSTOFFE“ (KHOCHHART100DE)

For more information on diamond cutting materials, please see our catalogue:
„ULTRA-HARD CUTTING MATERIALS“ (KHOCHHART100DE)

Geometrie .HF
Geometry

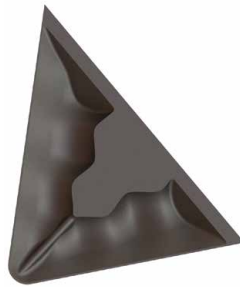

Bohrungsbearbeitung
bore machining

E

Werkstoff Material	Eckenradius Corner radius [mm]	HORN 3D-Spanleitstufe HORN 3D chip breaker .HF			
		Schnitttiefe a_p [mm] Depth of cut a_p [mm]		Vorschub f [mm/U] Feed rate f [mm/rev]	
		min	max	min	max
Aluminium, Knetlegierungen Aluminium, Wrought alloys	0,2	0,05	1,1	0,05	0,10
	0,4	0,07	1,2	0,06	0,15
Messing bleifrei Brass without lead	0,2	0,05	1,0	0,05	0,10
	0,4	0,1	1,2	0,08	0,15

Bei der Schnitttiefe a_p ist der Anstellwinkel des eingesetzten Klemmhalters zu beachten.
Please consider the a_p in relation to the approach angle of the toolholder.

D_{min} Angabe wird gegebenenfalls durch Materialeigenschaften beeinflusst.
The specified D_{min} value may be affected by material properties.

Werkstoff Material	Substrat Substrate	Einsatzgebiet Application	v_c m/min	f_n (mm/trs) (mm/giro)	a_p (mm)	Kühlung Coolant	
H gehärteter Stahl - <u>ohne</u> Schnittunterbrechung Hardened Steel - <u>without</u> interrupted cut 45-65 HRC	CB10	Ø 2,0 - Ø 4,0	80-140	0,01-0,03	0,01-0,05	Luft/Emulsion Air/Emulsion	
		> Ø 4,0	90-150	0,02-0,05	0,02-0,15		
	gehärteter Stahl - <u>mit</u> Schnittunterbrechung Hardened Steel - <u>with</u> interrupted cut 45-65 HRC	CB35	Ø 2,0 - Ø 4,0	90-150	0,01-0,03	0,01-0,05	Luft Air
			> Ø 4,0	100-160	0,02-0,05	0,02-0,15	
P Sinterstahl, weich (z.B. Sint D11) Sintered steel, soft < 220 HB	CH1G	Ø 2,0 - Ø 4,0	80-280	0,02-0,10	0,02-0,12	Emulsion Emulsion	
	CB35	> Ø 4,0	100-390	0,02-0,18	0,02-0,40		
K Grauguss "GG" (GJL) Grey cast iron < 240 HB	CB35	Ø 2,0 - Ø 4,0	300-1000	0,02-0,10	0,02-0,15	Emulsion/Luft Emulsion/Air	
		> Ø 4,0	400-1200	0,03-0,18	0,02-0,40		
	CB35	Ø 2,0 - Ø 4,0	150-650	0,02-0,07	0,02-0,12	Emulsion/Luft Emulsion/Air	
		> Ø 4,0	200-700	0,02-0,13	0,02-0,35		
	Grauguss „GGV“ (GJV) Grey cast iron 220-300 HB	CH1G CB35	Ø 2,0 - Ø 4,0	140-400	0,01-0,05	0,01-0,25	Emulsion/Luft Emulsion/Air
			> Ø 4,0	180-550	0,02-0,11	0,02-0,32	
ADl (vergütet / hardened)	CH1G	Ø 2,0 - Ø 4,0	50-110	0,01-0,025	0,01-0,05	Emulsion Emulsion	
		> Ø 4,0	80-130	0,01-0,06	0,015-0,25		
S Nickel-Basis und Superlegierungen Nickel based and Superalloys Schlichtbearbeitung / Finishing	CH1G	Ø 2,0 - Ø 4,0	140-250	0,01-0,03	0,01-0,06	Emulsion (Hochdruck) Emulsion (High pressure)	
		> Ø 4,0	180-350	0,01-0,045	0,01-0,18		
	CH1G	Ø 2,0 - Ø 4,0	60-200	0,01-0,025	0,01-0,04	Emulsion (Hochdruck) Emulsion (High pressure)	
		> Ø 4,0	100-300	0,01-0,05	0,01-0,08		

E

Nachstehende Drehmomente sind für die Spannschrauben zulässig. Wir empfehlen keine zusätzlichen Gleitmittel wie Kupferpaste oder ähnliches für die Schrauben zu verwenden.

Following torques are allowed for screws of inserts. We recommend to use no additional gliding means (such as copper paste) for screws.

Typ type	Schraube Screw	M_d Nm	Schlüssel Wrench	Klinge Blade
001	8.075.1835	5	SW4DIN911	DSW40K
125	3.512T10EP	3	T10PL	DT10PK
145	5.13T20EP	6,5	T20PQ	DT20PK / DT20PQ
962	6.075T15P	5	T15PQ	DT15PK
963	6.075T15P	5	T15PQ	DT15PK
AIH	030.3509.T15P	2,5	T10PL	DT10PK
	6.075T15P	5	T15PQ	DT15PK
B10P	2.6.5T8EP	1,2	T8PL	DT8PK
B11P	3.10T9P	1,8	T9PL	DT9PK
B18P	5.13T20EP	6	T20PQ	DT20PK / DT20PQ
B105	6.075T15P	5	T15PQ	DT15PK
B105.00...A...	030.00M8.1188	4	T25PQ	DT25PK / DT25PQ
B105.00...S...	030.0000.1157	2	T15PL	DT15PK
B105.A022...	030.0422T10P	2	T10PL	DT10PK
B106	1.8.4T6EP	0,9	T6PL	DT6PK
B107	2.2.5T7EP	1,1	T7PL	DT7PK
B108	2.6.5T8EP	1,2	T8PL	DT8PK
B109	6.075T15P	5	T15PQ	DT15PK
B110	6.075T15P	5	T15PQ	DT15PK
B111	3.512T10EP	3	T10PL	DT10PK
B114	4.12T15EP	5	T15PQ	DT15PK
B116	5.13T20EP	6,5	T20PQ	DT20PK / DT20PQ
BA114	4.12.T15P	5	T15PQ	DT15PK
BGT001	DIN912M5x10	5	SW4DIN911	DSW40K
BGT001.C...	DIN912M5x14	5	SW4DIN911	DSW40K
BKT	6.075T15P	5	T15PQ	DT15PK
BKT105...S...	030.0000.1157	2	T15PL	DT15PK
BU105	6.075T15P	5	T15PQ	DT15PK
BU105.00...S...	030.0000.1157	2	T15PL	DT15PK
H105	6.075T15P	5	T15PQ	DT15PK
HC105	6.075T15P	5	T15PQ	DT15PK
HC114	4.12T15EP	5	T15PQ	DT15PK
IR105	6.075T15P	5	T15PQ	DT15PK
KC760	5.12.T20P	6	T15PQ	DT15PK
N	6.075T15P	5	T15PQ	DT15PK
VDI	6.075T15P	5	T15PQ	DT15PK
WFB...105	6.075T15P	5	T15PQ	DT15PK
WFB...110	6.075T15P	5	T15PQ	DT15PK
WFB...14	4.12T15EP	5	T15PQ	DT15PK

E

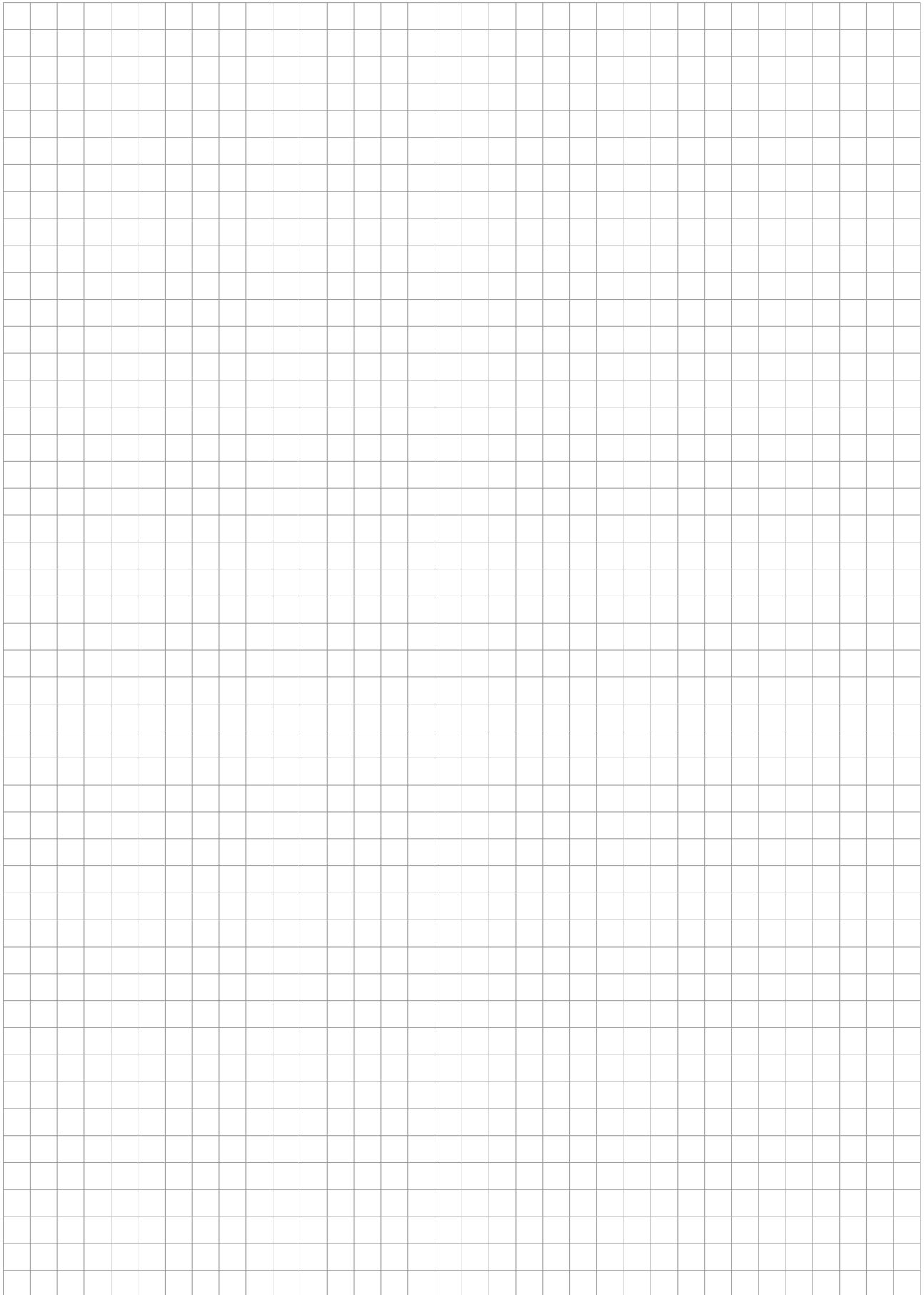

100/101



**Klemmhalter und
Schneidplatten**

**Toolholder and
Inserts**

Geometrien und
Vorschübe
Geometries and feed rates

Seite/Page
315-316

Klemmhalter
Toolholder
910/H100/H101

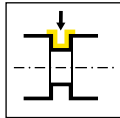

Seite/Page
317-336, 361

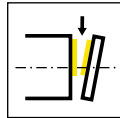

Seite/Page
337-350

Schneidplatte
Insert
S100/S101

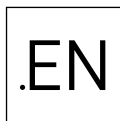

Seite/Page
351, 354

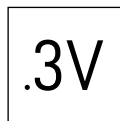

Seite/Page
352, 358

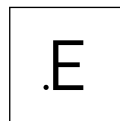

Seite/Page
353

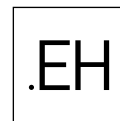

Seite/Page
355

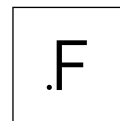

Seite/Page
356

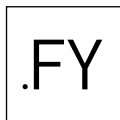

Seite/Page
357, 364

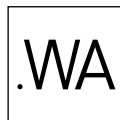

Seite/Page
359

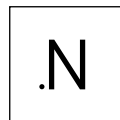

Seite/Page
360

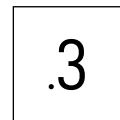

Seite/Page
362-363

F

Geometrien und Vorschübe

Geometries and feed rates



Geometrie Geometry	Werkstoff Material	Vorschubbereich f [mm/U] Feed rate f [mm/rev]	Bearbeitung Machining						
	<table border="1"> <tr> <td>P</td> <td>M</td> <td>K</td> </tr> <tr> <td>N</td> <td>S</td> <td>H</td> </tr> </table>	P	M	K	N	S	H	<p>↓ 0,15-0,25</p> <p>↔ 0,15-0,40</p>	
P	M	K							
N	S	H							
	<table border="1"> <tr> <td>P</td> <td>M</td> <td>K</td> </tr> <tr> <td>N</td> <td>S</td> <td>H</td> </tr> </table>	P	M	K	N	S	H	<p>↓ 0,05-0,20</p>	
P	M	K							
N	S	H							
	<table border="1"> <tr> <td>P</td> <td>M</td> <td>K</td> </tr> <tr> <td>N</td> <td>S</td> <td>H</td> </tr> </table>	P	M	K	N	S	H	<p>↓ 0,08-0,30</p>	
P	M	K							
N	S	H							
	<table border="1"> <tr> <td>P</td> <td>M</td> <td>K</td> </tr> <tr> <td>N</td> <td>S</td> <td>H</td> </tr> </table>	P	M	K	N	S	H	<p>↓ 0,25-0,4</p>	
P	M	K							
N	S	H							
	<table border="1"> <tr> <td>P</td> <td>M</td> <td>K</td> </tr> <tr> <td>N</td> <td>S</td> <td>H</td> </tr> </table>	P	M	K	N	S	H	<p>↓ 0,10-0,45</p>	
P	M	K							
N	S	H							



Geometrien und Vorschübe

Geometries and feed rates



Geometrie Geometry	Werkstoff Material	Vorschubbereich f [mm/U] Feed rate f [mm/rev]	Bearbeitung Machining						
	<table border="1"> <tr> <td>P</td> <td>M</td> <td>K</td> </tr> <tr> <td>N</td> <td>S</td> <td>H</td> </tr> </table>	P	M	K	N	S	H	<p>↓ 0,03-0,15</p>	
P	M	K							
N	S	H							
	<table border="1"> <tr> <td>P</td> <td>M</td> <td>K</td> </tr> <tr> <td>N</td> <td>S</td> <td>H</td> </tr> </table>	P	M	K	N	S	H	<p>↓ 0,03-0,15</p>	
P	M	K							
N	S	H							
	<table border="1"> <tr> <td>P</td> <td>M</td> <td>K</td> </tr> <tr> <td>N</td> <td>S</td> <td>H</td> </tr> </table>	P	M	K	N	S	H	<p>↓ 0,05-0,25</p> <p>↔ 0,05-0,25</p>	
P	M	K							
N	S	H							
	<table border="1"> <tr> <td>P</td> <td>M</td> <td>K</td> </tr> <tr> <td>N</td> <td>S</td> <td>H</td> </tr> </table>	P	M	K	N	S	H	<p>↓ 0,07-0,25</p>	
P	M	K							
N	S	H							

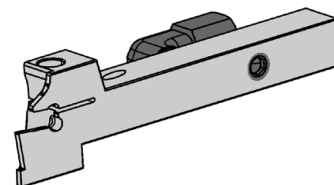
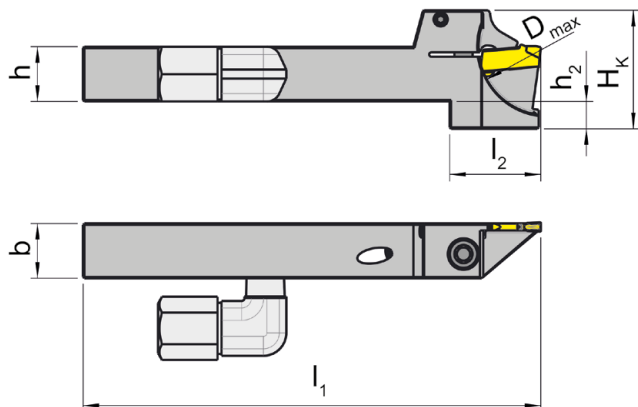
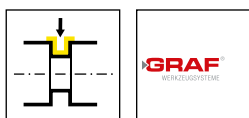

R = rechts wie gezeichnet
R = right hand version shown

L = links spiegelbildlich
L = left hand version

Bestellnummer Part number	h	b	l ₁	H _k	l ₂	h ₂	D _{max}	HWS
910.L.1012.01.2IK	10	12	100	24	20	6	20	100018
910.L.1212.01.2IK	12	12	100	26	20	6	26	100018
910.L.1616.01.2IK	16	16	100	34	25	10	42	100018
910.R.1012.01.2IK	10	12	100	24	20	6	20	100018
910.R.1212.01.2IK	12	12	100	26	20	6	26	100018
910.R.1616.01.2IK	16	16	100	34	25	10	42	100018



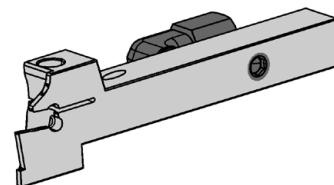
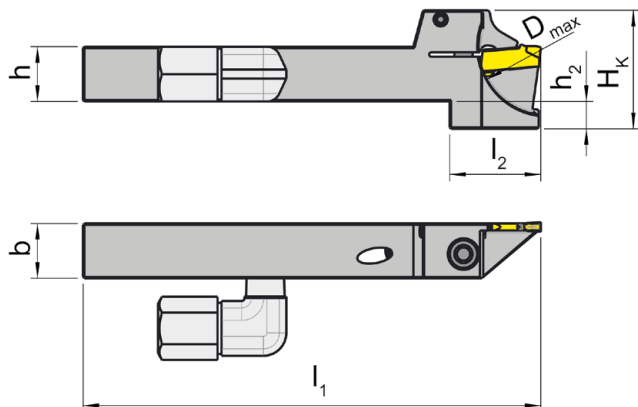
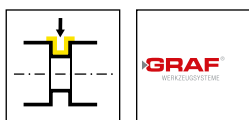

R = rechts wie gezeichnet
R = right hand version shown

L = links spiegelbildlich
L = left hand version

F

Bestellnummer Part number	h	b	l ₁	H _k	l ₂	h ₂	D _{max}	HWS
910.L.1012.02.2IK	10	12	100	24	20	6	20	100028
910.L.1212.02.2IK	12	12	100	26	20	6	26	100028
910.L.1616.02.2IK	16	16	100	34	25	10	42	100028
910.R.1012.02.2IK	10	12	100	24	20	6	20	100028
910.R.1212.02.2IK	12	12	100	26	20	6	26	100028
910.R.1616.02.2IK	16	16	100	34	25	10	42	100028
910.L.1212.03.2IK	12	12	100	26	20	6	26	100038
910.L.1616.03.2IK	16	16	100	34	25	10	42	100038
910.R.1212.03.2IK	12	12	100	26	20	6	26	100038
910.R.1616.03.2IK	16	16	100	34	25	10	42	100038

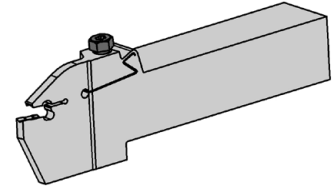
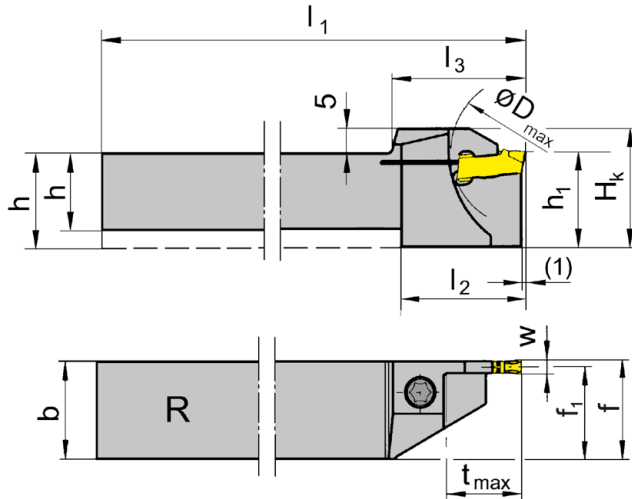
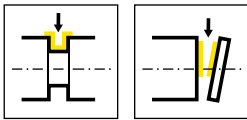

R = rechts wie gezeichnet
R = right hand version shown

L = links spiegelbildlich
L = left hand version

Bestellnummer Part number	h	b	l ₁	l ₂	l ₃	h ₁	f ₁	f	t _{max}	D _{max}	H _k	HWS
RH100.1010.01	10	10	125	19	21	13	9,25	f ₁ +w/2	10,5	21	18	100018
RH100.1010.11	10	10	125	21	23	16	9,25	f ₁ +w/2	13	42	21	100018
RH100.1212.01	12	12	125	21	23	16	11,25	f ₁ +w/2	13	26	21	100018
RH100.1212.11	12	12	125	21	26	16	11,25	f ₁ +w/2	16	42	21	100018
RH100.1616.11	16	16	125	24	26	20	15,25	f ₁ +w/2	16	42	25	100018
RH100.1616.21	16	16	125	30	33,5	20	15,25	f ₁ +w/2	21	42	25	100018
RH100.2020.11	20	20	125	-	26	20	19,25	f ₁ +w/2	16	42	25	100018
RH100.2020.21	20	20	125	-	33,5	20	19,25	f ₁ +w/2	21	42	25	100018
LH100.1010.01	10	10	125	19	21	13	9,25	f ₁ +w/2	10,5	21	18	100018
LH100.1010.11	10	10	125	21	23	16	9,25	f ₁ +w/2	13	42	21	100018
LH100.1212.01	12	12	125	21	23	16	11,25	f ₁ +w/2	13	26	21	100018
LH100.1212.11	12	12	125	21	26	16	11,25	f ₁ +w/2	16	42	21	100018
LH100.1616.11	16	16	125	24	26	20	15,25	f ₁ +w/2	16	42	25	100018
LH100.1616.21	16	16	125	30	33,5	20	15,25	f ₁ +w/2	21	42	25	100018
LH100.2020.11	20	20	125	-	33,5	20	19,25	f ₁ +w/2	16	42	25	100018
LH100.2020.21	20	20	125	-	33,5	20	19,25	f ₁ +w/2	21	42	25	100018

w siehe Schneidplatten
w see inserts

Ersatzteile

Spare Parts

Klemmhalter Toolholder	Spannschraube Clamping Screw	TORX PLUS®-Schlüssel TORX PLUS® Wrench
R/LH100...	4.15T15P	T15PQ



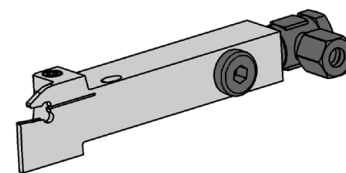
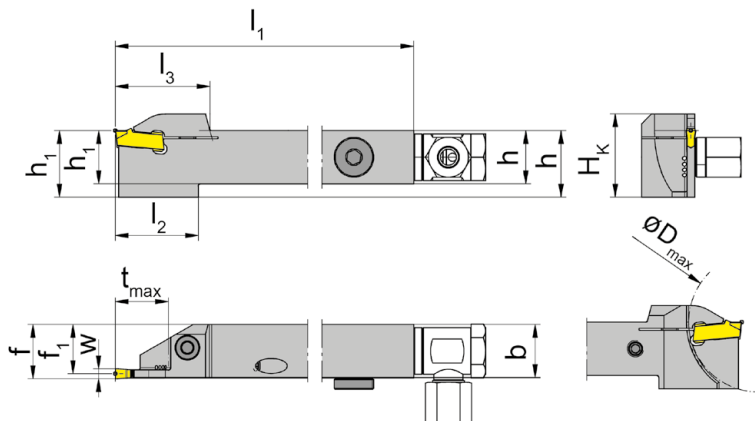
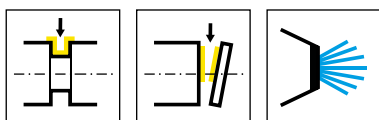

F

R = rechts wie gezeichnet
R = right hand version shown

L = links spiegelbildlich
L = left hand version

Bestellnummer Part number	h	b	l ₁	l ₂	l ₃	h ₁	f ₁	f	t _{max}	D _{max}	H _k	HWS
RH100.1212.01.IK	12	12	125	21	23	12	11,25	f ₁ +w/2	13	26	21	100018
RH100.1212.11.IK	12	12	125	21	26	12	11,25	f ₁ +w/2	16	42	21	100018
RH100.1616.11.IK	16	16	125	24	26	16	15,25	f ₁ +w/2	16	42	25	100018
RH100.1616.21.IK	16	16	125	30	33,5	16	15,25	f ₁ +w/2	21	42	25	100018
RH100.2020.11.IK	20	20	125	-	33,5	20	19,25	f ₁ +w/2	16	42	25	100018
RH100.2020.21.IK	20	20	125	-	33,5	20	19,25	f ₁ +w/2	21	42	25	100018
LH100.1212.01.IK	12	12	125	21	23	12	11,25	f ₁ +w/2	13	26	21	100018
LH100.1212.11.IK	12	12	125	21	26	12	11,25	f ₁ +w/2	16	42	21	100018
LH100.1616.11.IK	16	16	125	24	26	16	15,25	f ₁ +w/2	16	42	25	100018
LH100.1616.21.IK	16	16	125	30	33,5	16	15,25	f ₁ +w/2	21	42	25	100018
LH100.2020.11.IK	20	20	125	-	33,5	20	19,25	f ₁ +w/2	16	42	25	100018
LH100.2020.21.IK	20	20	125	-	33,5	20	19,25	f ₁ +w/2	21	42	25	100018

w siehe Schneidplatten
w see inserts

Ersatzteile

Spare Parts

Klemmhalter Toolholder	Spannschraube Clamping Screw	Kühlmittelanschluss Coolant supply	TORX PLUS®-Schlüssel TORX PLUS® Wrench	Verschlusschraube Screw Plug
R/LH100.1212...	4.15T15P	004.00.22	T15PQ	
R/LH100...	4.15T15P	004.00.16	T15PQ	004.00.26
R/LH100.2020.21.IK	4.15T15P	004.00.16	T20PQ	004.00.26

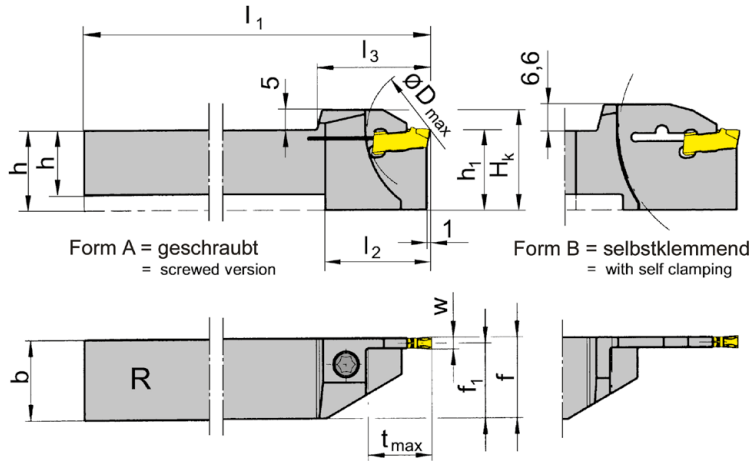
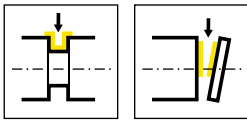

R = rechts wie gezeichnet
R = right hand version shown

L = links spiegelbildlich
L = left hand version

Bestellnummer Part number	h	b	l ₁	l ₂	l ₃	h ₁	f ₁	f	t _{max}	D _{max}	H _k	Form	HWS
RH100.1212.02	12	12	125	21	23	16	11,05	f ₁ +w/2	13	25	21	A	100028
RH100.1616.02	16	16	125	19	21	20	15,05	f ₁ +w/2	10,5	42	25	A	100028
RH100.1212.12	12	12	125	24	26	16	11,05	f ₁ +w/2	16	42	25	A	100028
RH100.1616.12	16	16	125	24	26	20	15,05	f ₁ +w/2	16	42	25	A	100028
RH100.2020.12	20	20	125	-	26	20	19,05	f ₁ +w/2	16	42	25	A	100028
RH100.1616.22	16	16	125	30	33,5	20	15,05	f ₁ +w/2	21	42	25	A	100028
RH100.2020.22	20	20	125	-	33,5	20	19,05	f ₁ +w/2	21	42	25	A	100028
RH100.2020.32	20	20	125	35	38,5	25	19,05	f ₁ +w/2	32,5	65	31,6	B	100028
LH100.1212.02	12	12	125	21	23	16	11,05	f ₁ +w/2	13	25	21	A	100028
LH100.1616.02	16	16	125	19	21	20	15,05	f ₁ +w/2	10,5	42	25	A	100028
LH100.1212.12	12	12	125	24	26	16	11,05	f ₁ +w/2	16	42	25	A	100028
LH100.1616.12	16	16	125	24	26	20	15,05	f ₁ +w/2	16	42	25	A	100028
LH100.2020.12	20	20	125	-	26	20	19,05	f ₁ +w/2	16	42	25	A	100028
LH100.1616.22	16	16	125	30	33,5	20	15,05	f ₁ +w/2	21	42	25	A	100028
LH100.2020.22	20	20	125	-	33,5	20	19,05	f ₁ +w/2	21	42	25	A	100028
LH100.2020.32	20	20	125	35	38,5	25	19,05	f ₁ +w/2	32,5	65	31,6	B	100028

w siehe Schneidplatten
w see inserts

Der Schlüssel **P39L** gehört nicht zum Lieferumfang des Schneidenträgers R/LH100.2020.32. Bitte separat bestellen!
Wrench P39L is not combined with blade R/LH100.2020.32 - separate order required!

Ersatzteile

Spare Parts

Klemmhalter Toolholder	Spannschraube Clamping Screw	TORX PLUS®-Schlüssel TORX PLUS® Wrench
R/LH100...	4.15T15P	T15PQ



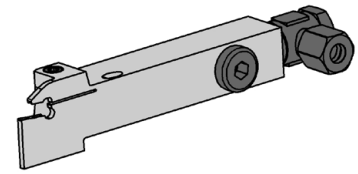
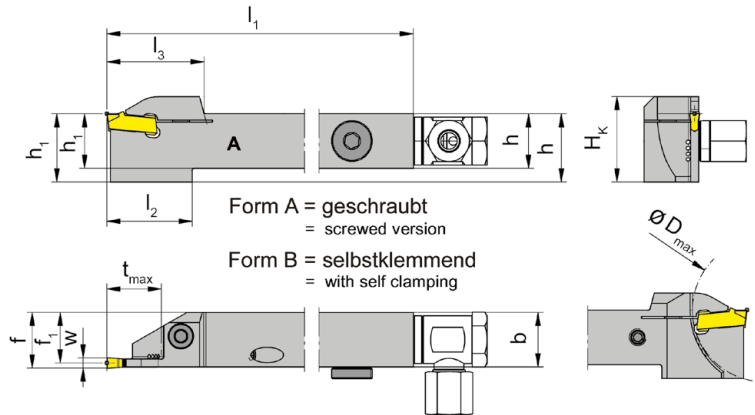
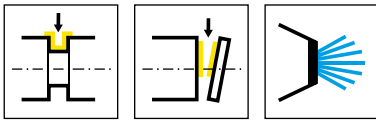

R = rechts wie gezeichnet
R = right hand version shown

L = links spiegelbildlich
L = left hand version

Bestellnummer Part number	h	b	l ₁	l ₂	l ₃	h ₁	f ₁	f	t _{max}	D _{max}	H _k	Form	HWS
RH100.1212.02.IK	12	12	125	21	23	16	11,05	f ₁ +w/2	13	25	21	A	100028
RH100.1616.02.IK	16	16	125	19	21	20	15,05	f ₁ +w/2	10,5	42	25	A	100028
RH100.1212.12.IK	12	12	125	24	26	16	11,05	f ₁ +w/2	16	42	25	A	100028
RH100.1616.12.IK	16	16	125	24	28,5	20	15,05	f ₁ +w/2	16	42	25	A	100028
RH100.2020.12.IK	20	20	125	-	26	20	19,05	f ₁ +w/2	16	42	25	A	100028
RH100.1616.22.IK	16	16	125	30	33,5	20	15,05	f ₁ +w/2	21	42	25	A	100028
RH100.2020.22.IK	20	20	125	-	33,5	20	19,05	f ₁ +w/2	21	42	25	A	100028
LH100.1212.02.IK	12	12	125	21	23	16	11,05	f ₁ +w/2	13	25	21	A	100028
LH100.1616.02.IK	16	16	125	19	21	20	15,05	f ₁ +w/2	10,5	42	25	A	100028
LH100.1616.12.IK	16	16	125	24	28,5	20	15,05	f ₁ +w/2	16	42	25	A	100028
LH100.2020.12.IK	20	20	125	-	26	20	19,05	f ₁ +w/2	16	42	25	A	100028
LH100.1616.22.IK	16	16	125	30	33,5	20	15,05	f ₁ +w/2	21	42	25	A	100028
LH100.2020.22.IK	20	20	125	-	33,5	20	19,05	f ₁ +w/2	21	42	25	A	100028

w siehe Schneidplatten
w see inserts

Ersatzteile

Spare Parts

Klemmhalter Toolholder	Spannschraube Clamping Screw	Kühlmittelanschluss Coolant supply	TORX PLUS®-Schlüssel TORX PLUS® Wrench	Verschlusschraube Screw Plug
RH100.1212.12.IK	4.15T15P	004.00.22	T15PQ	
R/LH100...	4.15T15P	004.00.16	T15PQ	004.00.26
R/LH100.2020.22.IK	5.17T20P		T20PQ	

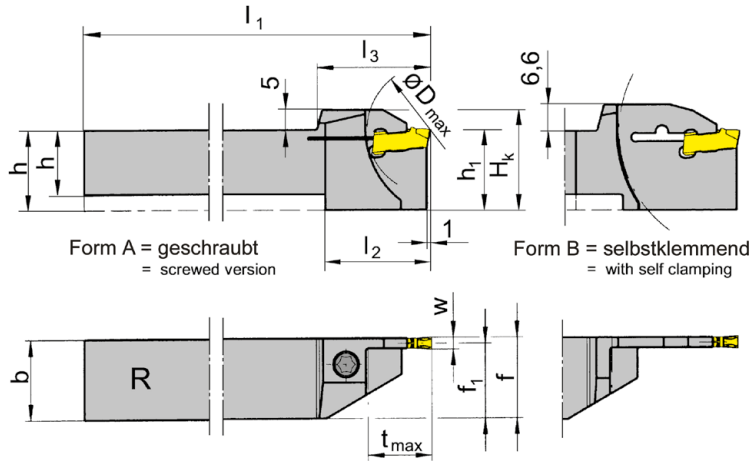
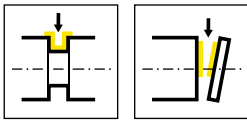

R = rechts wie gezeichnet
R = right hand version shown

L = links spiegelbildlich
L = left hand version

Bestellnummer Part number	h	b	l ₁	l ₂	l ₃	h ₁	f ₁	f	t _{max}	D _{max}	H _k	Form	HWS
RH100.1212.03	12	12	125	21	23	16	10,85	f ₁ +w/2	13	26	25	A	100028
RH100.1616.03	16	16	125	19,5	23	20	14,85	f ₁ +w/2	10,5	42	25	A	100038
RH100.1616.13	16	16	125	25	28,5	20	14,85	f ₁ +w/2	16	42	25	A	100038
RH100.1616.23	16	16	125	30	33,5	20	14,85	f ₁ +w/2	21	42	25	A	100038
RH100.2020.13	20	20	125	-	28,5	20	18,85	f ₁ +w/2	16	42	25	A	100038
RH100.2020.23	20	20	125	-	33,5	20	18,85	f ₁ +w/2	21	42	25	-	100038
RH100.2020.33	20	20	125	35	38,5	25	18,85	f ₁ +w/2	32,5	65	31,6	B	100038
LH100.1212.03	12	12	125	21	23	16	10,85	f ₁ +w/2	13	26	25	A	100028
LH100.1616.03	16	16	125	19,5	23	20	14,85	f ₁ +w/2	10,5	42	25	A	100038
LH100.1616.13	16	16	125	25	28,5	20	14,85	f ₁ +w/2	16	42	25	A	100038
LH100.1616.23	16	16	125	30	33,5	20	14,85	f ₁ +w/2	21	42	25	A	100038
LH100.2020.13	20	20	125	-	28,5	20	18,85	f ₁ +w/2	16	42	25	A	100038
LH100.2020.23	20	20	125	-	33,5	20	18,85	f ₁ +w/2	21	42	25	A	100038
LH100.2020.33	20	20	125	35	38,5	25	18,85	f ₁ +w/2	32,5	65	31,6	B	100038

w siehe Schneidplatten
w see inserts

Der Schlüssel **P39L** gehört nicht zum Lieferumfang des Schneidenträgers R/LH100...33. Bitte separat bestellen!
Wrench P39L is not combined with blade R/LH100...33 - separate order required!

Ersatzteile

Spare Parts

Klemmhalter Toolholder	Spannschraube Clamping Screw	TORX PLUS®-Schlüssel TORX PLUS® Wrench
R/LH100...	3.5.12T10EP	T10PL



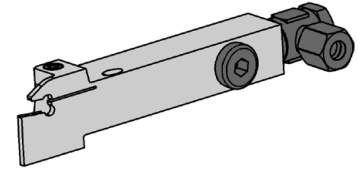
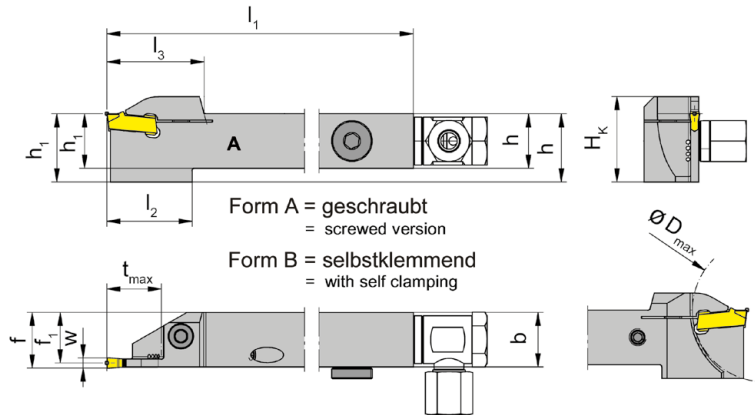
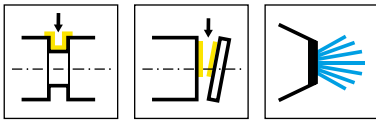

R = rechts wie gezeichnet
R = right hand version shown

L = links spiegelbildlich
L = left hand version

F

Bestellnummer Part number	h	b	l ₁	l ₂	l ₃	h ₁	f ₁	f	t _{max}	D _{max}	H _k	Form	HWS
RH100.1212.03.IK	12	12	125	21	23	16	10,85	f ₁ +w/2	13	26	25	A	100038
RH100.1616.03.IK	16	16	125	19,5	23	20	14,85	f ₁ +w/2	10,5	42	25	A	100038
RH100.1616.13.IK	16	16	125	25	28,5	20	14,85	f ₁ +w/2	16	42	25	A	100038
RH100.2020.13.IK	20	20	125	-	28,5	20	18,85	f ₁ +w/2	16	42	25	A	100038
RH100.1616.23.IK	16	16	125	30	33,5	20	14,85	f ₁ +w/2	21	42	25	A	100038
RH100.2020.23.IK	20	20	125	-	33,5	20	18,85	f ₁ +w/2	21	42	25	A	100038
RH100.2020.33.IK	20	20	125	35	38,5	25	18,85	f ₁ +w/2	32,5	65	31,6	B	100038
LH100.1212.03.IK	12	12	125	21	23	16	10,85	f ₁ +w/2	13	26	25	A	100038
LH100.1616.03.IK	16	16	125	19,5	23	20	14,85	f ₁ +w/2	10,5	42	25	A	100038
LH100.1616.13.IK	16	16	125	25	28,5	20	14,85	f ₁ +w/2	16	42	25	A	100038
LH100.2020.13.IK	20	20	125	-	28,5	20	18,85	f ₁ +w/2	16	42	25	A	100038
LH100.1616.23.IK	16	16	125	30	33,5	20	14,85	f ₁ +w/2	21	42	25	A	100038
LH100.2020.23.IK	20	20	125	-	33,5	20	18,85	f ₁ +w/2	21	42	25	A	100038
LH100.2020.33.IK	20	20	125	35	38,5	25	18,85	f ₁ +w/2	32,5	65	31,6	B	100038

w siehe Schneidplatten
w see inserts

Der Schlüssel **P39L** gehört nicht zum Lieferumfang des Schneidenträgers R/LH100...33. Bitte separat bestellen!
Wrench P39L is not combined with blade R/LH100...33 - separate order required!

Ersatzteile

Spare Parts

Klemmhalter Toolholder	Spannschraube Clamping Screw	Kühlmittelsanschluss Coolant supply	TORX PLUS®-Schlüssel TORX PLUS® Wrench	Verschlusschraube Screw Plug
R/LH100.1212.03.IK	5.17T20P	004.00.22	T20PQ	-
R/LH100...	5.17T20P	004.00.16	T20PQ	004.00.26
RH100.1616.23.IK	4.15T15P	004.00.16	T15PQ	004.00.26

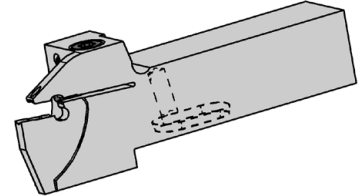
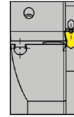
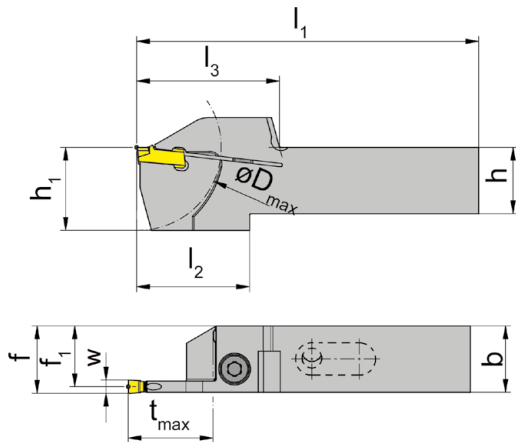
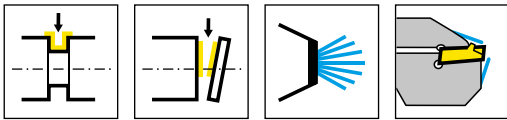

R = rechts wie gezeichnet
R = right hand version shown

L = links spiegelbildlich
L = left hand version

Bestellnummer Part number	h	b	l ₁	l ₂	l ₃	h ₁	f ₁	f	t _{max}	D _{max}	HWS
RH100.1616.2.23.IK	16	16	89	35	39	25	14,65	f ₁ +w/2	21,5	42	100038
RH100.2020.2.23.IK	20	20	102	33	39	25	18,65	f ₁ +w/2	21,5	42	100038
RH100.2020.2.73.IK	20	20	106	37	43	25	18,65	f ₁ +w/2	25,5	50	100038
RH100.2020.34.4.73.IK	20	20	115	48	53	30	18,65	f ₁ +w/2	34	68	100038
LH100.1616.2.23.IK	16	16	89	35	39	25	14,65	f ₁ +w/2	21,5	42	100038
LH100.2020.2.23.IK	20	20	102	33	39	25	18,65	f ₁ +w/2	21,5	42	100038
LH100.2020.2.73.IK	20	20	106	37	43	25	18,65	f ₁ +w/2	25,5	50	100038
LH100.2020.34.4.73.IK	20	20	115	48	53	30	18,65	f ₁ +w/2	34	68	100038

w siehe Schneidplatten
w see inserts

Ersatzteile
Spare Parts

Klemmhalter Toolholder	Spannschraube Clamping Screw	TORX PLUS®-Schlüssel TORX PLUS® Wrench
R/LH100...	6.23T25P	T25PQ



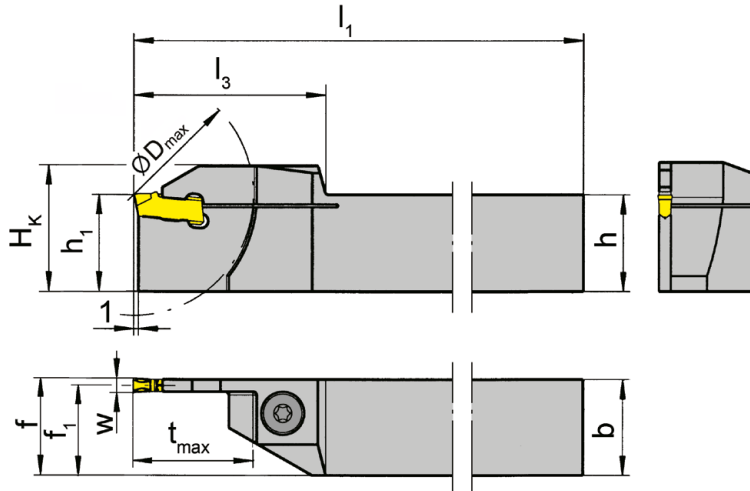
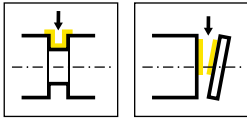

L = links wie gezeichnet
L = left hand version shown

R = rechts spiegelbildlich
R = right hand version

Bestellnummer Part number	h	b	l ₁	l ₃	h ₁	f ₁	f	t _{max}	D _{max}	H _K	HWS
RH100.2020.73	20	20	125	40	20	18,85	f ₁ +w/2	25	50	26	100038
RH100.2020.74	20	20	125	40	20	18,85	f ₁ +w/2	25	50	26	100048
LH100.2020.73	20	20	125	40	20	18,85	f ₁ +w/2	25	50	26	100038
LH100.2020.74	20	20	125	40	20	18,85	f ₁ +w/2	25	50	26	100048

w siehe Schneidplatten
w see inserts

Ersatzteile
Spare Parts

Klemmhalter Toolholder	Spannschraube Clamping Screw	TORX PLUS®-Schlüssel TORX PLUS® Wrench
R/LH100...	6.23T25P	T25PQ

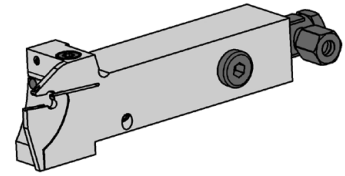
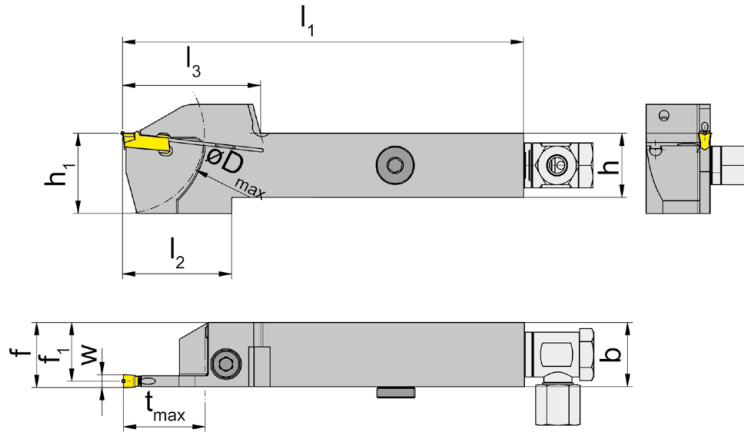
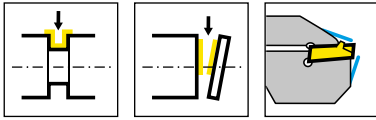

R = rechts wie gezeichnet
R = right hand version shown

L = links spiegelbildlich
L = left hand version

Bestellnummer Part number	h	b	l ₁	l ₂	l ₃	h ₁	f ₁	f	t _{max}	D _{max}	HWS
RH100.1616.0.23.IK	16	20	125	35	39	25	14,65	f ₁ +w/2	21,5	42	100038
RH100.1616.0.24.IK	16	20	125	35	39	25	14,3	f ₁ +w/2	21,5	42	100048
RH100.2020.0.23.IK	20	20	125	33	39	25	18,65	f ₁ +w/2	21,5	42	100038
RH100.2020.0.24.IK	20	20	125	33	39	25	18,3	f ₁ +w/2	21,5	42	100048
LH100.1616.0.23.IK	16	16	125	35	39	25	14,65	f ₁ +w/2	21,5	42	100038
LH100.1616.0.24.IK	16	16	125	35	39	25	14,3	f ₁ +w/2	21,5	42	100048
LH100.2020.0.23.IK	20	20	125	33	39	25	18,65	f ₁ +w/2	21,5	42	100038
LH100.2020.0.24.IK	20	20	125	33	39	25	18,3	f ₁ +w/2	21,5	42	100048

w siehe Schneidplatten
w see inserts

Ersatzteile
Spare Parts

Klemmhalter Toolholder	Kühlmittelanschluss Coolant supply	Spannschraube Clamping Screw	TORX PLUS®-Schlüssel TORX PLUS® Wrench	Verschlusschraube Screw Plug
R/LH100...	004.00.16	6.23T25P	T25PQ	004.00.26



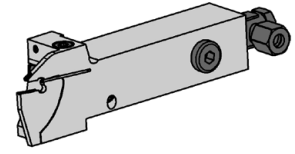
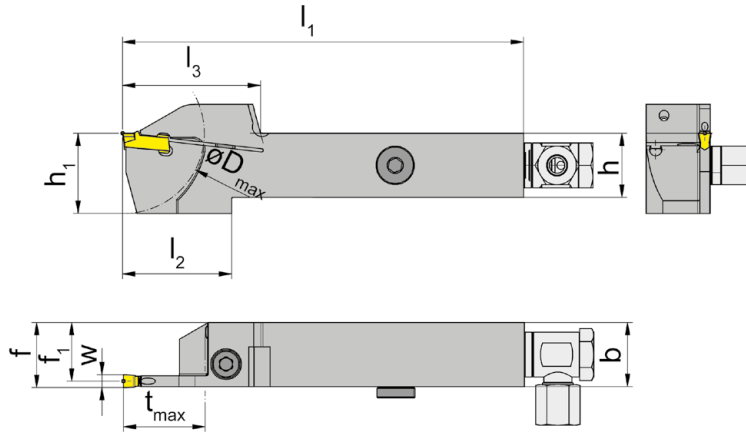
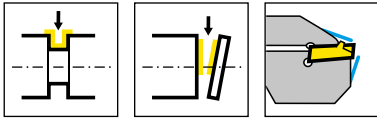

R = rechts wie gezeichnet
R = right hand version shown

L = links spiegelbildlich
L = left hand version

Bestellnummer Part number	h	b	l ₁	l ₂	l ₃	h ₁	f ₁	f	t _{max}	D _{max}	HWS
RH100.2020.0.73.IK	20	20	125	37	43	25	18,65	f ₁ +w/2	25,5	50	100038
LH100.2020.0.73.IK	20	20	125	37	43	25	18,65	f ₁ +w/2	25,5	50	100038
LH100.2020.0.74.IK	20	20	125	37	43	25	18,3	f ₁ +w/2	25,5	50	100048

w siehe Schneidplatten
w see inserts

Ersatzteile
Spare Parts

Klemmhalter Toolholder	Kühlmittelanschluss Coolant supply	Spannschraube Clamping Screw	TORX PLUS®-Schlüssel TORX PLUS® Wrench	Verschlusschraube Screw Plug
R/LH100.2020.0.73.IK	004.00.16	6.23T25P	T25PQ	004.00.26
LH100.2020.0.74.IK	004.00.16	6.23T25P	T20PQ	004.00.26

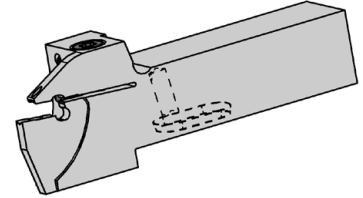
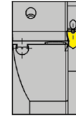
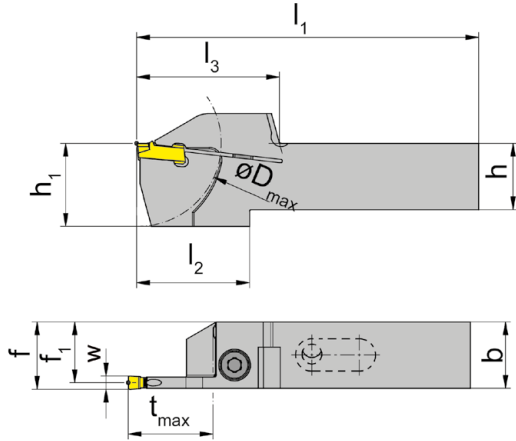
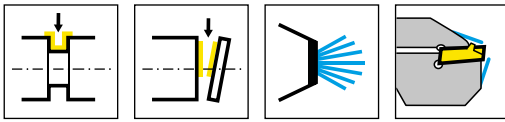

R = rechts wie gezeichnet
R = right hand version shown

L = links spiegelbildlich
L = left hand version

Bestellnummer Part number	h	b	l ₁	l ₂	l ₃	h ₁	f ₁	f	t _{max}	D _{max}	HWS
RH100.1616.2.24.IK	16	16	89	35	39	25	14,3	f ₁ +w/2	21,5	42	100048
RH100.2020.2.24.IK	20	20	102	33	39	25	18,3	f ₁ +w/2	21,5	42	100048
RH100.2020.2.74.IK	20	20	106	37	43	25	18,3	f ₁ +w/2	25,5	50	100048
LH100.1616.2.24.IK	16	16	89	35	39	25	14,3	f ₁ +w/2	21,5	42	100048
LH100.2020.2.24.IK	20	20	102	33	39	25	18,3	f ₁ +w/2	21,5	42	100048
LH100.2020.2.74.IK	20	20	106	37	43	25	18,3	f ₁ +w/2	25,5	50	100048

w siehe Schneidplatten
w see inserts

Ersatzteile
Spare Parts

Klemmhalter Toolholder	Spannschraube Clamping Screw	TORX PLUS®-Schlüssel TORX PLUS® Wrench
R/LH100...	6.23T25P	T25PQ



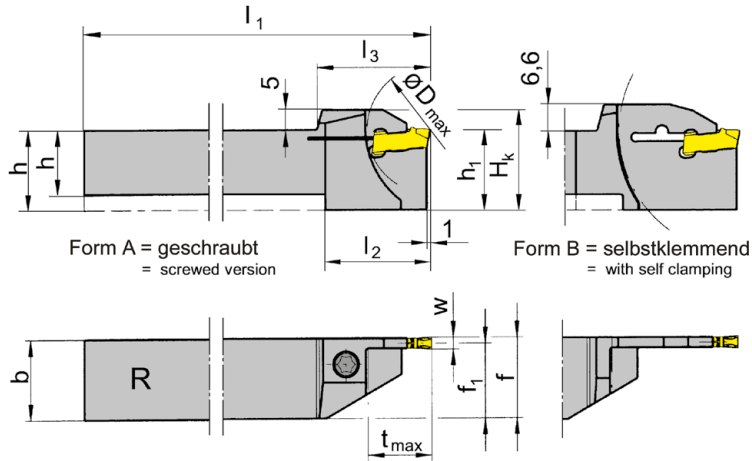
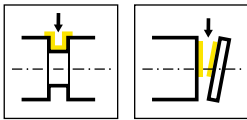

R = rechts wie gezeichnet
R = right hand version shown

L = links spiegelbildlich
L = left hand version

Bestellnummer Part number	h	b	l ₁	l ₂	l ₃	h ₁	f ₁	f	t _{max}	D _{max}	H _k	Form	HWS
RH100.1616.04	16	16	125	19,5	23	20	14,45	f ₁ +w/2	10,5	42	25	A	100048
RH100.1616.14	16	16	125	25	28,5	20	14,45	f ₁ +w/2	16	42	25	A	100048
RH100.2020.14	20	20	125	-	28,5	20	18,45	f ₁ +w/2	16	42	25	A	100048
RH100.2020.34	20	20	125	35	38,5	25	18,45	f ₁ +w/2	32,5	65	31,6	B	100048
LH100.1616.04	16	16	125	19,5	23	20	14,45	f ₁ +w/2	10,5	42	25	A	100048
LH100.1616.14	16	16	125	25	28,5	20	14,45	f ₁ +w/2	16	42	25	A	100048
LH100.2020.14	20	20	125	-	28,5	20	18,45	f ₁ +w/2	16	42	25	A	100048
LH100.1616.24	16	16	125	30	33,5	20	14,45	f ₁ +w/2	21	42	25	A	100048
LH100.2020.34	20	20	125	35	38,5	25	18,45	f ₁ +w/2	32,5	65	31,6	B	100048

w siehe Schneidplatten
w see inserts

Der Schlüssel **P39L** gehört nicht zum Lieferumfang des Schneidenträgers R/LH100...34. Bitte separat bestellen!
Wrench P39L is not combined with blade R/LH100...34 - separate order required!

Ersatzteile

Spare Parts

Klemmhalter Toolholder	Spannschraube Clamping Screw	TORX PLUS®-Schlüssel TORX PLUS® Wrench
R/LH100...	5.17T20P	T20PQ

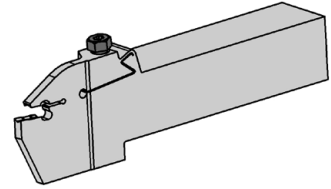
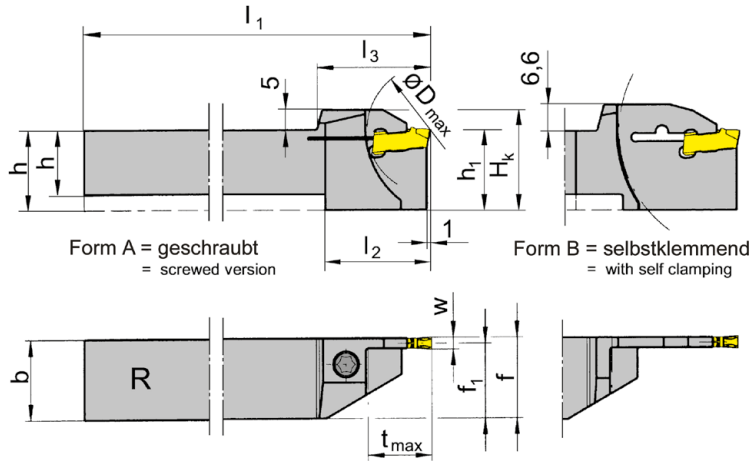
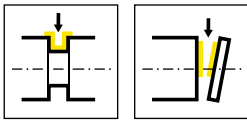

R = rechts wie gezeichnet
R = right hand version shown

L = links spiegelbildlich
L = left hand version

Bestellnummer Part number	h	b	l ₁	l ₂	l ₃	h ₁	f ₁	f	t _{max}	D _{max}	H _k	Form	HWS
RH100.2020.15	20	20	125	-	28,5	20	18,05	f ₁ +w/2	16	42	25	A	100058
RH100.2020.35	20	20	125	35	38,5	20	18,05	f ₁ +w/2	32,5	65	31,6	B	100058
LH100.2020.15	20	20	125	-	28,5	20	18,05	f ₁ +w/2	16	42	25	A	100058
LH100.2020.35	20	20	125	35	38,5	25	18,05	f ₁ +w/2	32,5	65	31,6	B	100058

w siehe Schneidplatten
w see inserts

Der Schlüssel **P39L** gehört nicht zum Lieferumfang des Schneidenträgers R/LH100...35. Bitte separat bestellen!
Wrench P39L is not combined with blade R/LH100...35 - separate order required!

Ersatzteile

Spare Parts

Klemmhalter Toolholder	Spannschraube Clamping Screw	TORX PLUS®-Schlüssel TORX PLUS® Wrench
R/LH100....	5.17T20P	T20PQ



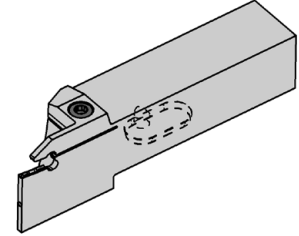
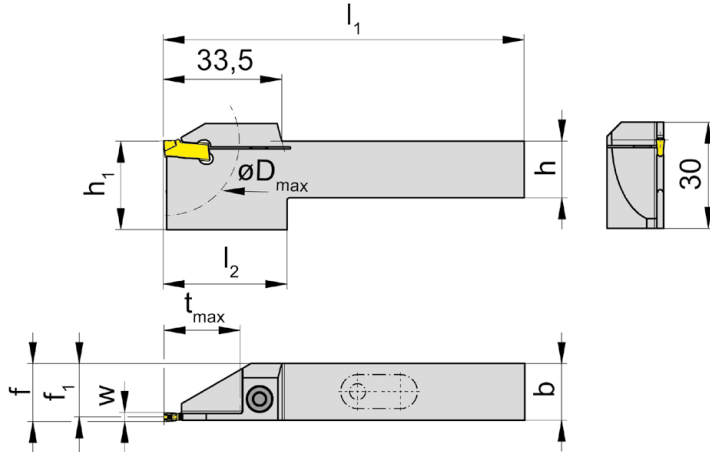
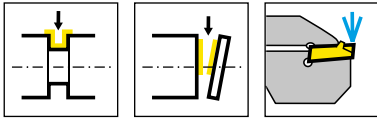

R = rechts wie gezeichnet
R = right hand version shown

L = links spiegelbildlich
L = left hand version

F

Bestellnummer Part number	h	b	l ₁	l ₂	h ₁	f ₁	f	t _{max}	D _{max}	HWS
RH100.2020.3.22.IK	20	20	102	35	25	19,05	f ₁ +w/2	21,5	42	100029
LH100.1616.3.22.IK	16	16	89	35	25	15,05	f ₁ +w/2	21,5	42	100029
LH100.2020.3.22.IK	20	20	102	35	25	19,05	f ₁ +w/2	21,5	42	100029

w siehe Schneidplatten
w see inserts

Ersatzteile

Spare Parts

Klemmhalter Toolholder	Spannschraube Clamping Screw	TORX PLUS®-Schlüssel TORX PLUS® Wrench
R/LH100...	5.17T20P	T20PQ

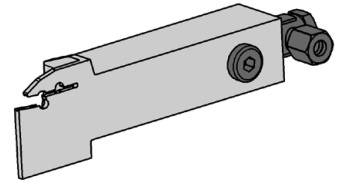
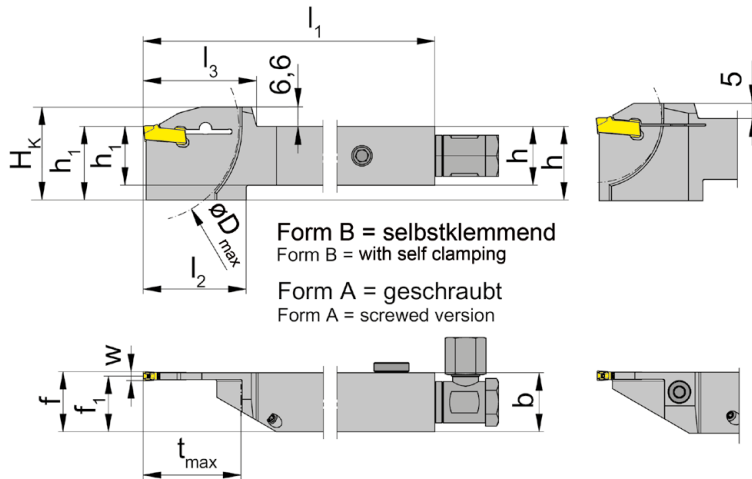
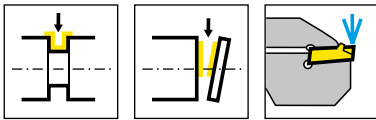

L = links wie gezeichnet
L = left hand version shown

R = rechts spiegelbildlich
R = right hand version

Bestellnummer Part number	h	b	l ₁	l ₂	l ₃	h ₁	f ₁	f	t _{max}	D _{max}	H _K	Form	HWS
RH100.1616.1.23.IK	16	16	125	35	33,5	27	14,85	f ₁ +w/2	21,5	42	32	A	100039
RH100.2020.1.13.IK	20	20	125	30	28,5	27	18,85	f ₁ +w/2	16	42	32	A	100039
RH100.2020.1.23.IK	20	20	125	35	33,5	27	18,85	f ₁ +w/2	21,5	42	32	A	100039
RH100.2020.1.33.IK	20	20	125	35	38,5	27	18,85	f ₁ +w/2	33	65	33,6	B	100039
RH100.2020.1.34.IK	20	20	125	35	38,5	27	18,45	f ₁ +w/2	33	65	33,6	B	100039
LH100.1616.1.23.IK	16	16	125	35	33,5	27	14,85	f ₁ +w/2	21,5	42	32	A	100039
LH100.2020.1.13.IK	20	20	125	30	28,5	27	18,85	f ₁ +w/2	16	42	32	A	100039
LH100.2020.1.23.IK	20	20	125	35	33,5	27	18,85	f ₁ +w/2	21,5	42	32	A	100039
LH100.2020.1.33.IK	20	20	125	35	38,5	27	18,85	f ₁ +w/2	33	65	33,6	B	100039

w siehe Schneidplatten
w see inserts

Der Schlüssel **P39L** gehört nicht zum Lieferumfang des Schneidenträgers H100...33/...34. Bitte separat bestellen!
Wrench P39L is not combined with blade H100...33/...34 separate order required!

Ersatzteile

Spare Parts

Klemmhalter Toolholder	Spannschraube Clamping Screw	Kühlmittelanschluss Coolant supply	TORX PLUS®-Schlüssel TORX PLUS® Wrench	Verschlusschraube Screw Plug	Spannschlüssel Wrench
R/LH100...	5.17T20P	004.00.16	T20PQ	004.00.26	
R/LH100...33.IK/...34.IK		004.00.16		004.00.26	P39L

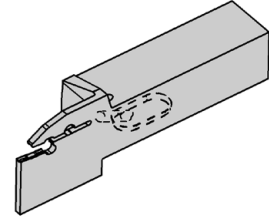
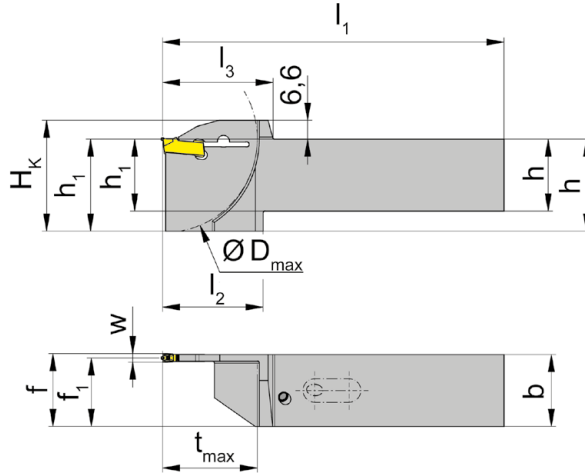
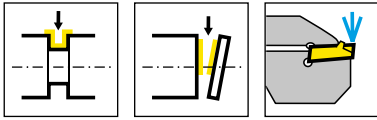

L = links wie gezeichnet
L = left hand version shown

R = rechts spiegelbildlich
R = right hand version

Bestellnummer Part number	h	b	l ₁	l ₂	l ₃	h ₁	f ₁	f	t _{max}	D _{max}	H _K	HWS
RH100.2020.3.33.IK	20	20	104	35	38,5	27	18,85	f ₁ +w/2	33	65	33,6	100039
LH100.2020.3.33.IK	20	20	104	35	38,5	27	18,85	f ₁ +w/2	33	65	33,6	100039

w siehe Schneidplatten
w see inserts

Der Schlüssel **P39L** gehört nicht zum Lieferumfang des Schneidenträgers R/LH100...33. Bitte separat bestellen!
Wrench P39L is not combined with blade R/LH100...33 - separate order required!

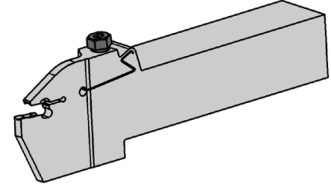
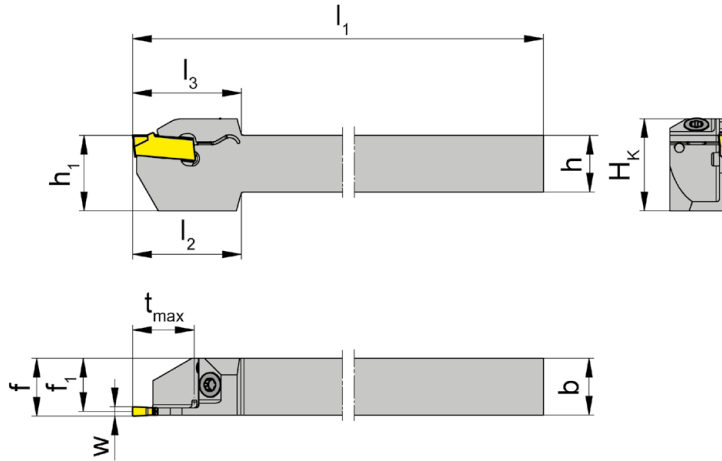
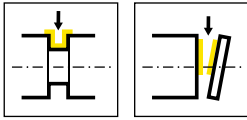

R = rechts wie gezeichnet
R = right hand version shown

L = links spiegelbildlich
L = left hand version

Bestellnummer Part number	h	b	l ₁	l ₂	l ₃	h ₁	f ₁	f	t _{max}	D _{max}	H _k	HWS
RH100.1212.24.61	12	12	125	23	23	16	11,25	f ₁ +w/2	13	26	19,5	100018
RH100.1212.32.63	12	12	125	27	24	16	10,85	f ₁ +w/2	17	34	19,5	100038
RH100.1616.24.61	16	16	125	23	-	16	15,25	f ₁ +w/2	13	26	19,5	100018
RH100.1616.32.63	16	16	125	27	-	16	14,85	f ₁ +w/2	17	34	19,5	100038
LH100.1212.24.61	12	12	125	23	23	16	11,25	f ₁ +w/2	13	26	19,5	100018
LH100.1212.32.63	12	12	125	24	27	16	10,85	f ₁ +w/2	17	34	19,5	100038
LH100.1616.24.61	16	16	125	-	23	16	15,25	f ₁ +w/2	13	26	19,5	100018
LH100.1616.32.63	16	16	125	-	27	16	14,85	f ₁ +w/2	17	34	19,5	100038

w siehe Schneidplatten
w see inserts

Ersatzteile
Spare Parts

Klemmhalter Toolholder	Spannschraube Clamping Screw	TORX PLUS®-Schlüssel TORX PLUS® Wrench
R/LH100...	3.5.12T10EP	T10PL



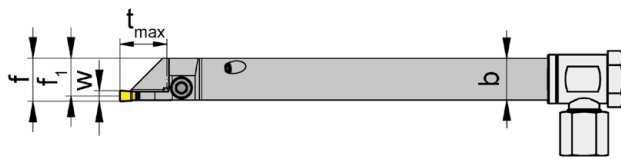
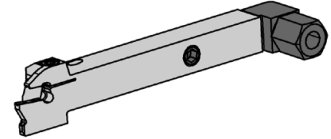
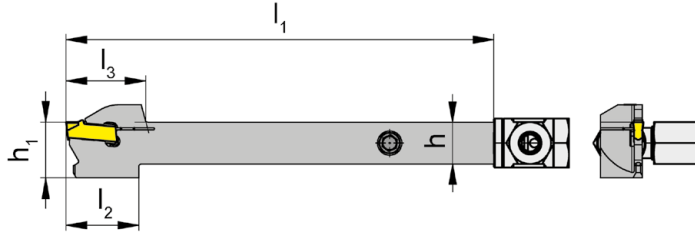
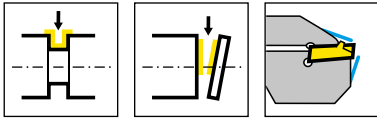

R = rechts wie gezeichnet
R = right hand version shown

L = links spiegelbildlich
L = left hand version

Bestellnummer Part number	h	b	l ₁	l ₂	l ₃	h ₁	f ₁	f	t _{max}	D _{max}	HWS
RH100.1212.5.23.IK	12	12	125	21	23	16	10,85	f ₁ +w/2	13,5	26	100038
LH100.1212.5.23.IK	12	12	125	21	23	16	10,85	f ₁ +w/2	13,5	26	100038

w siehe Schneidplatten
w see inserts

Ersatzteile
Spare Parts

Klemmhalter Toolholder	Spannschraube Clamping Screw	Kühlmittelananschluss Coolant supply	TORX PLUS®-Schlüssel TORX PLUS® Wrench
R/LH100.1212.5.23.IK	4.15T15P	004.00.61	T15PQ

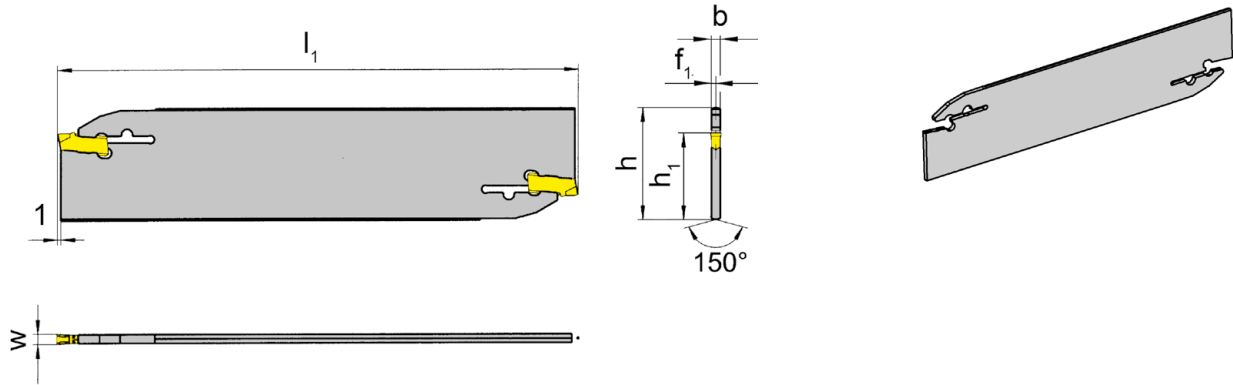
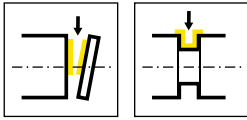

Bestellnummer Part number	h	b	l ₁	h ₁	f ₁	t _{max}	HWS
H100.2601.01	26	1,5	110	21,4	0,75	25	100018
H100.2602.02	26	1,9	110	21,4	0,95	37,5	100028
H100.2603.03	26	2,3	110	21,4	1,15	37,5	100038
H100.2604.04	26	3,1	110	21,8	1,65	40	100048
H100.3201.01	32	1,5	150	24,8	0,75	25	100018
H100.3202.02	32	1,9	150	24,8	0,95	50	100028
H100.3203.03	32	2,3	150	24,8	1,15	50	100038
H100.3204.04	32	3,1	160	24,8	1,65	55	100048
H100.3205.05	32	3,9	160	24,8	2	55	100058

w siehe Schneidplatten
w see inserts

Der Schlüssel **P39L** gehört nicht zum Lieferumfang des Schneidenträgers. Bitte separat bestellen!
Wrench P39L is not combined with toolholder - separate order required!



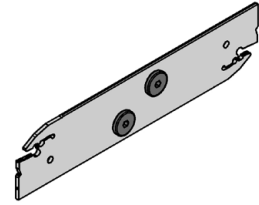
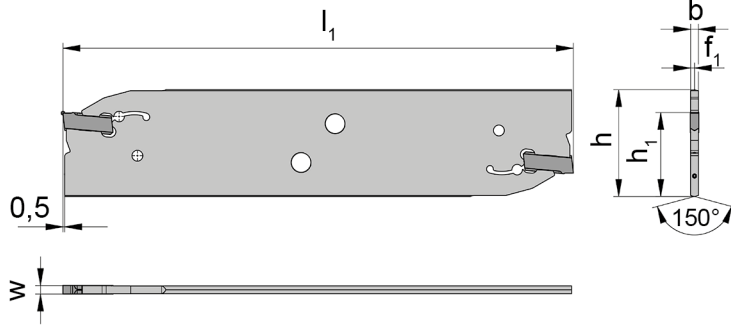
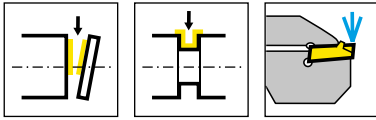

F

Bestellnummer Part number	h	b	l ₁	h ₁	f ₁	t _{max}	HWS
H100.2602.8.02.IK	26	1,9	110	21,4	0,95	35	100029 • 100028
H100.2603.8.03.IK	26	2,3	110	21,4	1,15	35	100039 • 100038
H100.2604.8.04.IK	26	3,1	110	21,4	1,55	35	100049 • 100048
H100.3202.8.02.IK	32	1,9	150	24,8	0,95	55	100029 • 100028
H100.3203.8.03.IK	32	2,3	150	24,8	1,15	60	100039 • 100038
H100.3204.8.04.IK	32	3,1	150	24,8	1,55	60	100049 • 100048

Der Schlüssel P101.02 gehört nicht zum Lieferumfang des Halters. Bitte separat bestellen!
Wrench P101.02 is not combined with slotting cutter - separate order required!

Ersatzteile

Spare Parts

Klemmhalter Toolholder	IK-Verschluss Coolant plug
H100...	020.IK01.5732

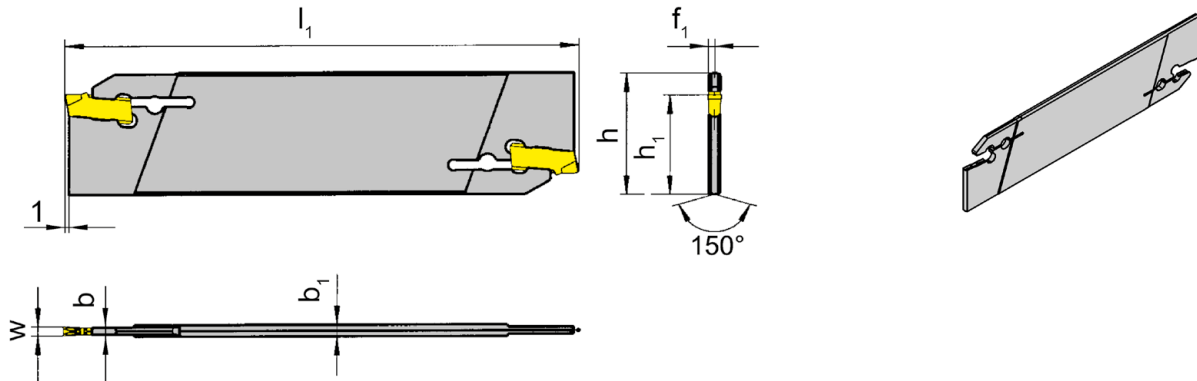
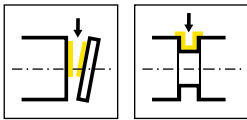

Bestellnummer Part number	h	b	l_1	h_1	f_1	t_{max}	b_1	HWS
H100.2603.01	26	1,5	110	21,4	1,15	21	2,3	100018
H100.2603.02	26	1,9	110	21,4	1,15	21	2,3	100028
H100.3203.01	32	1,5	150	24,8	1,15	25	2,3	100018
H100.3203.02	32	1,9	150	24,8	1,15	25	2,3	100028

Der Schlüssel **P39L** gehört nicht zum Lieferumfang des Schneidenträgers. Bitte separat bestellen!
Wrench P39L is not combined with toolholder - separate order required!



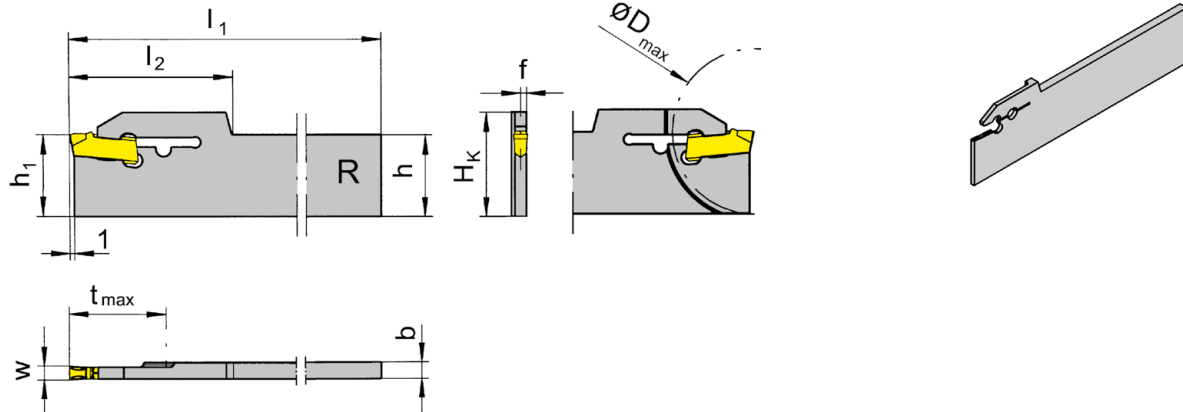
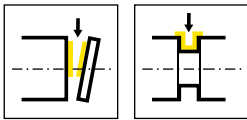

R = Rechtsausführung
R = right hand version

F

Bestellnummer Part number	H _k	b	l ₁	h ₁	f	l ₂	t _{max}	D _{max}	h	HWS
RH100.1703.21	22,1	3,2	110	17,4	0,75	32	17,5	35	17,4	100018
RH100.2203.21	26,9	3,2	150	22,2	0,75	32	32	50	22,1	100018
RH100.1703.33	22,1	3,2	110	17,4	1,15	34,5	30	60	17,4	100038
RH100.2203.33	26,9	3,2	150	22,2	1,15	34,5	38	76	22,1	100038

w siehe Schneidplatten
w see inserts

Der Schlüssel **P39L** gehört nicht zum Lieferumfang des Schneidenträgers R/LH100...33. Bitte separat bestellen!
Wrench P39L is not combined with blade R/LH100...33 - separate order required!

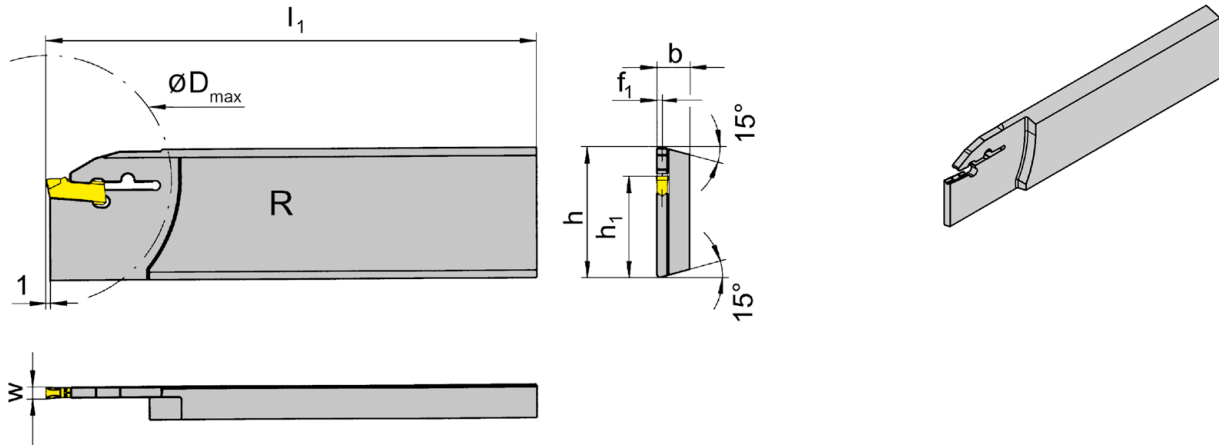
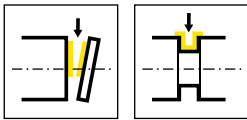

R = rechts wie gezeichnet
R = right hand version shown

L = links spiegelbildlich
L = left hand version

Bestellnummer Part number	h	b	l ₁	h ₁	f ₁	t _{max}	D _{max}	HWS
RH100.2608.31	26	7,9	110	21,4	0,75	21	42	100018
RH100.2608.32	26	7,9	110	21,4	0,95	25	50	100028
RH100.2608.33	26	7,9	110	21,4	1,15	25	50	100038
RH100.3208.31	32	7,9	112	24,8	0,75	25	50	100018
RH100.3208.32	32	7,9	112	24,8	0,95	34	68	100028
RH100.3208.33	32	7,9	112	24,8	1,15	34	68	100038
RH100.3208.34	32	7,9	112	24,8	1,55	34	68	100048
LH100.2608.31	26	7,9	110	21,4	0,75	21	42	100018
LH100.2608.32	26	7,9	110	21,4	0,95	25	50	100028
LH100.2608.33	26	7,9	110	21,4	1,15	25	50	100038
LH100.2608.34	26	7,9	110	21,4	1,55	25	50	100048
LH100.3208.31	32	7,9	112	24,8	0,75	25	50	100018
LH100.3208.32	32	7,9	112	24,8	0,95	34	68	100028
LH100.3208.33	32	7,9	112	24,8	1,15	34	68	100038
LH100.3208.34	32	7,9	112	24,8	1,55	34	68	100048

w siehe Schneidplatten
w see inserts

Der Schlüssel **P39L** gehört nicht zum Lieferumfang des Schneidenträgers. Bitte separat bestellen!
Wrench P39L is not combined with toolholder - separate order required!



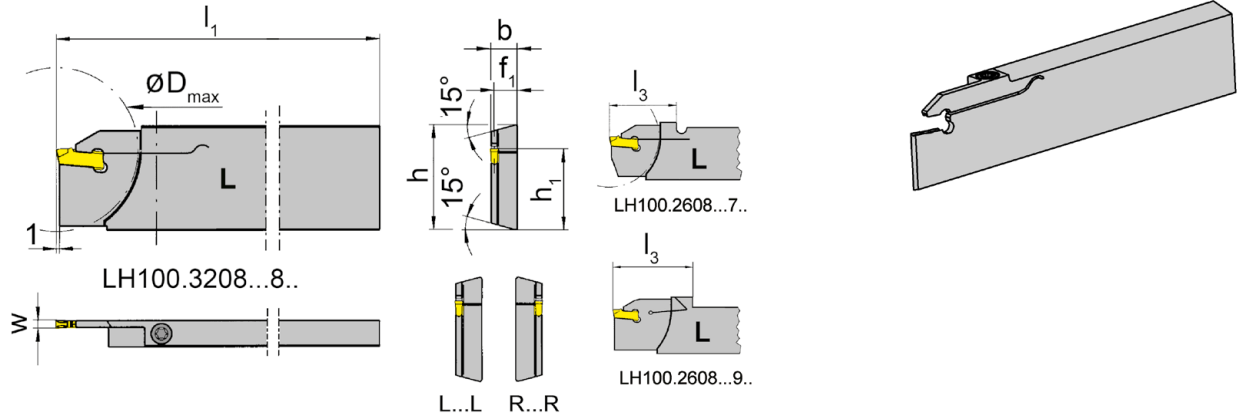
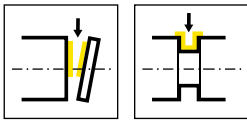

L = links wie gezeichnet
L = left hand version shown

R = rechts spiegelbildlich
R = right hand version

F

Bestellnummer Part number	h	b	l ₁	h ₁	f ₁	l ₃	t _{max}	D _{max}	HWS
RH100.2608.71R	26	7,9	110	21,4	7,15	33,8	25	50	100018
RH100.3208.71R	32	7,9	112	24,8	7,15	33,8	25	50	100018
RH100.2608.72R	26	7,9	110	21,4	6,95	33,8	25	50	100028
RH100.3208.72R	32	7,9	112	24,8	6,95	33,8	25	50	100028
RH100.2608.93R	26	8	115	21,4	6,85	40	25	50	100038
RH100.3208.93R	32	8	115	24,8	6,85	42	32,5	65	100038
LH100.2608.71L	26	7,9	110	21,4	7,15	33,8	25	50	100018
LH100.3208.71L	32	7,9	112	24,8	7,15	33,8	25	50	100018
LH100.2608.72L	26	7,9	110	21,4	6,95	33,8	25	50	100028
LH100.3208.72L	32	7,9	112	24,8	6,95	33,8	25	50	100028
LH100.2608.93L	26	8	115	21,4	6,85	40	25	50	100038
LH100.3208.93L	32	8	115	24,8	6,85	42	32,5	65	100038

w siehe Schneidplatten
w see inserts

Ersatzteile

Spare Parts

Klemmhalter Toolholder	Spannschraube Clamping Screw	TORX PLUS®-Schlüssel TORX PLUS® Wrench
R/LH100...	4.15T15P	T15PQ
R/LH100...93R/L	030.0413.T15P	T15PQ

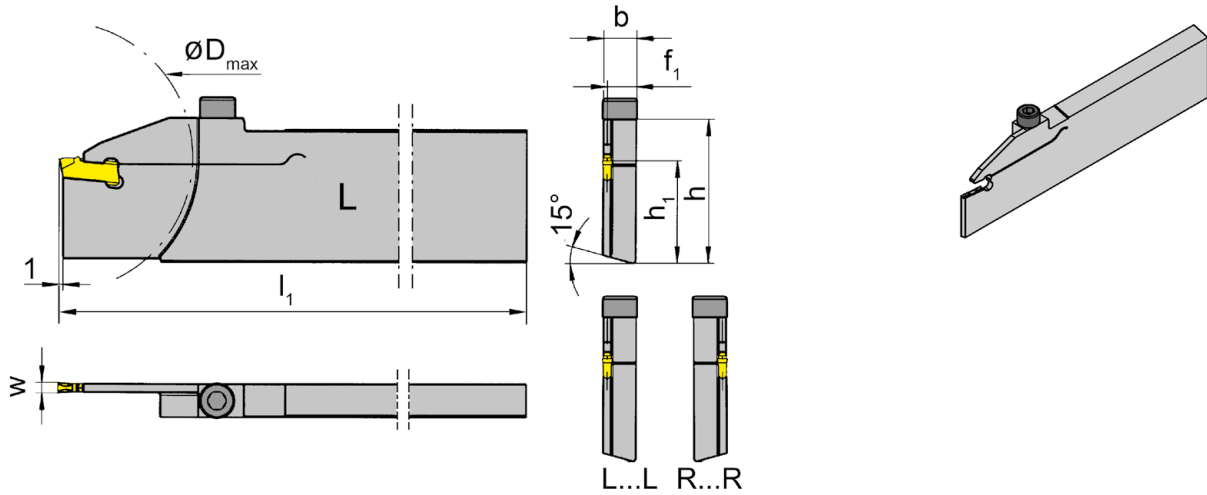
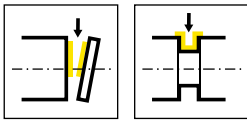

L = links wie gezeichnet
L = left hand version shown

R = rechts spiegelbildlich
R = right hand version

Bestellnummer Part number	h	b	l_1	h_1	f_1	t_{max}	D_{max}	HWS
RH100.3280.73R	32	7,9	130	24,8	6,75	32,5	65	100038
RH100.3280.74R	32	7,9	130	24,8	6,35	32,5	65	100048
LH100.3280.73L	32	7,9	130	24,8	6,75	32,5	65	100038
LH100.3280.74L	32	7,9	130	24,8	6,35	32,5	65	100048

w siehe Schneidplatten
w see inserts



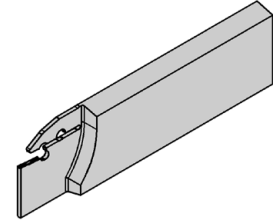
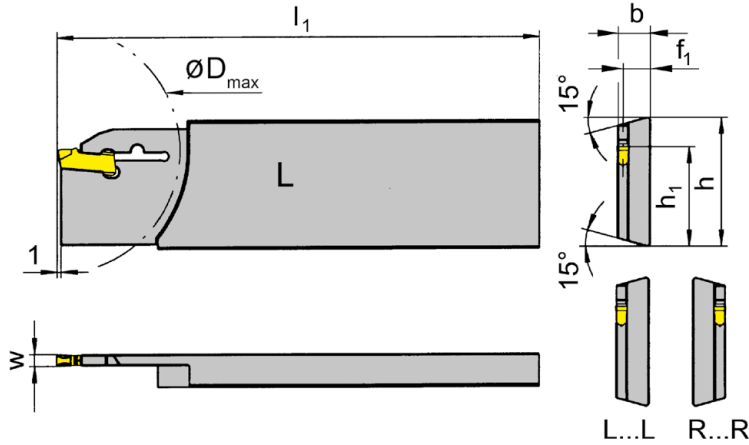
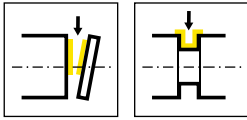

L = links wie gezeichnet
L = left hand version shown

R = rechts spiegelbildlich
R = right hand version

F

Bestellnummer Part number	h	b	l_1	h_1	f_1	t_{max}	D_{max}	HWS
RH100.2608.31R	26	7,9	110	21,4	7,15	21	42	100018
RH100.3208.31R	32	7,9	112	24,8	7,15	25	50	100018
RH100.2608.32R	26	7,9	110	21,4	6,95	25	50	100028
RH100.3208.32R	32	7,9	112	24,8	6,95	34	68	100028
RH100.2608.33R	26	7,9	110	21,4	6,75	25	50	100038
RH100.3208.33R	32	7,9	112	24,8	6,75	34	68	100038
RH100.2608.34R	26	7,9	110	21,4	6,35	25	50	100048
RH100.3208.34R	32	7,9	112	24,8	6,35	34	68	100048
LH100.2608.31L	26	7,9	110	21,4	7,15	21	42	100018
LH100.3208.31L	32	7,9	112	24,8	7,15	25	50	100018
LH100.2608.32L	26	7,9	110	21,4	6,95	25	50	100028
LH100.3208.32L	32	7,9	112	24,8	6,95	34	68	100028
LH100.2608.33L	26	7,9	110	21,4	6,75	25	50	100038
LH100.3208.33L	32	7,9	112	24,8	6,75	34	68	100038
LH100.2608.34L	26	7,9	110	21,4	6,35	25	50	100048
LH100.3208.34L	32	7,9	112	24,8	6,35	34	68	100048

w siehe Schneidplatten
w see inserts

Der Schlüssel **P39L** gehört nicht zum Lieferumfang des Schneidenträgers. Bitte separat bestellen!
Wrench P39L is not combined with toolholder - separate order required!

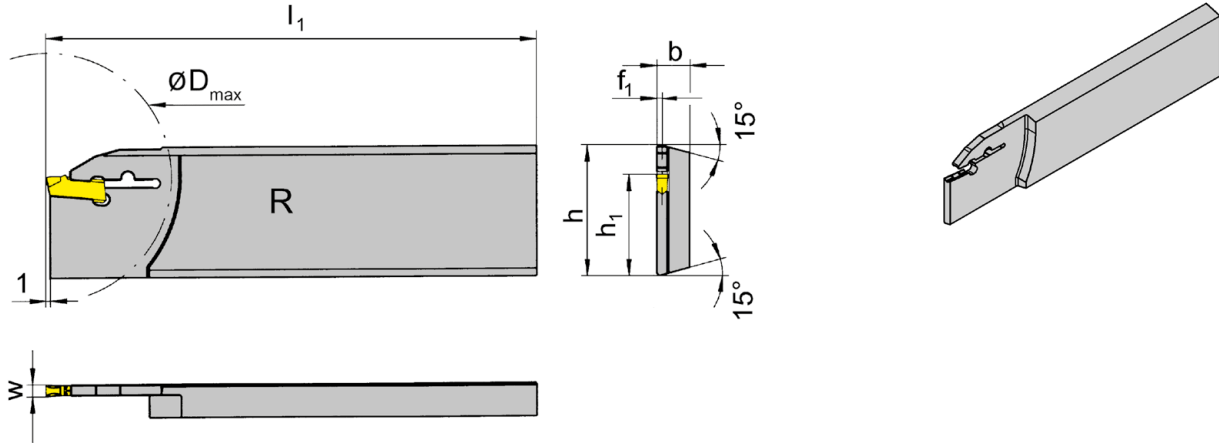
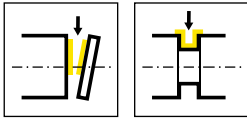

R = Rechtsausführung
R = right hand version

Bestellnummer Part number	h	b	l ₁	h ₁	f ₁	t _{max}	D _{max}	HWS
RH100.3208.2.44	32	7,9	160	24,8	1,55	41	80	100048
RH100.3208.44	32	7,9	130	24,8	1,55	41	80	100048

w siehe Schneidplatten
w see inserts

Der Schlüssel **P39L** gehört nicht zum Lieferumfang des Schneidenträgers. Bitte separat bestellen!
Wrench P39L is not combined with toolholder - separate order required!



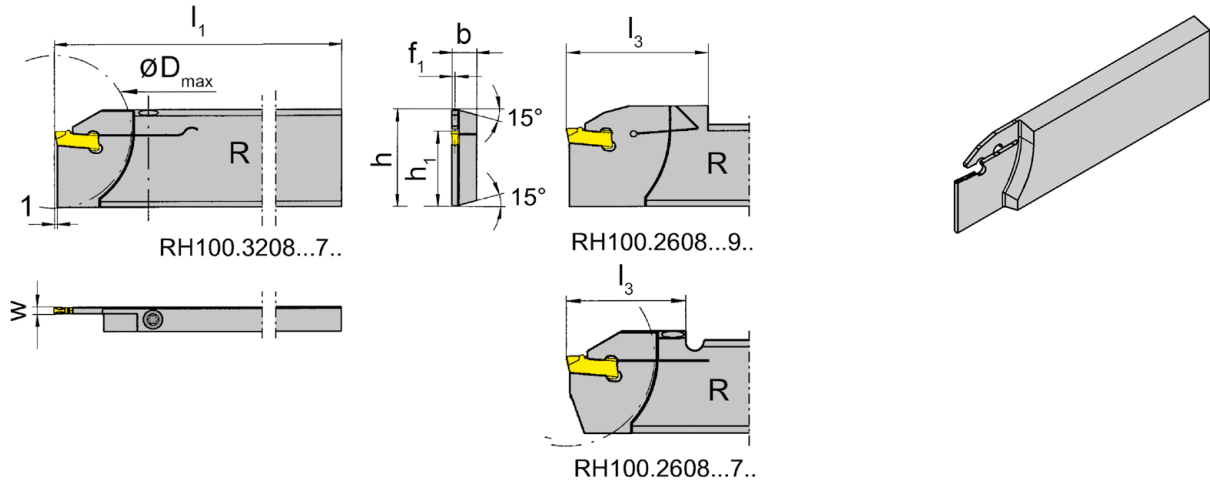
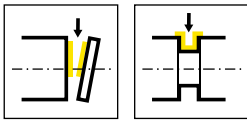

R = rechts wie gezeichnet
R = right hand version shown

L = links spiegelbildlich
L = left hand version

F

Bestellnummer Part number	h	b	l ₁	h ₁	f ₁	l ₃	t _{max}	D _{max}	HWS
RH100.2608.71	26	7,9	110	21,4	0,75	33,8	25	50	100018
RH100.3208.71	32	7,9	112	24,8	0,75	33,8	25	50	100018
RH100.2608.72	26	7,9	110	21,4	0,95	33,8	25	50	100028
RH100.3208.72	32	7,9	112	24,8	0,95	33,8	25	50	100028
RH100.2608.93	26	8	112	21,4	1,15	40	25	50	100038
RH100.3208.93	32	8	112	24,8	1,15	40	32,5	65	100038
LH100.2608.71	26	7,9	110	21,4	0,75	33,8	25	50	100018
LH100.3208.71	32	7,9	112	24,8	0,75	33,8	25	50	100018
LH100.2608.72	26	7,9	110	21,4	0,95	33,8	25	50	100028
LH100.3208.72	32	7,9	112	24,8	0,95	33,8	25	50	100028
LH100.2608.93	26	8	112	21,4	1,15	40	25	50	100038
LH100.3208.93	32	8	112	24,8	1,15	40	32,5	65	100038

w siehe Schneidplatten
w see inserts

Ersatzteile

Spare Parts

Klemmhalter Toolholder	Spannschraube Clamping Screw	TORX PLUS®-Schlüssel TORX PLUS® Wrench
R/LH100...	4.15T15P	T15PQ
R/LH100...93	030.0413.T15P	T15PQ

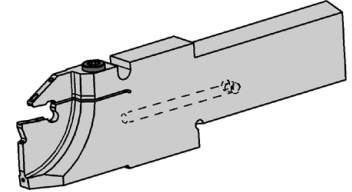
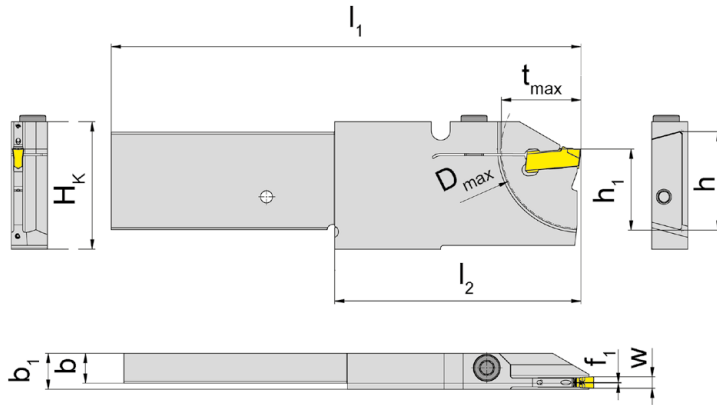
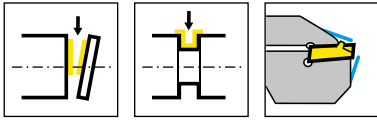

R = rechts wie gezeichnet
R = right hand version shown

L = links spiegelbildlich
L = left hand version

Bestellnummer Part number	H _k	h	b	l ₁	h ₁	f	t _{max}	l ₂	D _{max}	b ₁	HWS
RH100.2608.2.16.4.72.IK	33,6	26	7,9	124	21,4	0,2	16	65	32	9,5	100028
RH100.2608.2.16.4.72R.IK	33,6	26	7,9	124	21,4	6,4	16	65	32	9,5	100028
RH100.2608.2.21.4.73.IK	33,6	26	7,9	124	21,4	0,2	21	65	42	9,5	100038
RH100.2608.2.21.4.73R.IK	33,6	26	7,9	124	21,4	6,4	21	65	42	9,5	100038

für DMG MORI (Multisprint)
for machines DMG MORI (Multisprint)

w siehe Schneidplatten
w see inserts

Ersatzteile
Spare Parts

Klemmhalter Toolholder	Spannschraube Clamping Screw	TORX PLUS®-Schlüssel TORX PLUS® Wrench
RH100...	5.13T20P	T20PQ



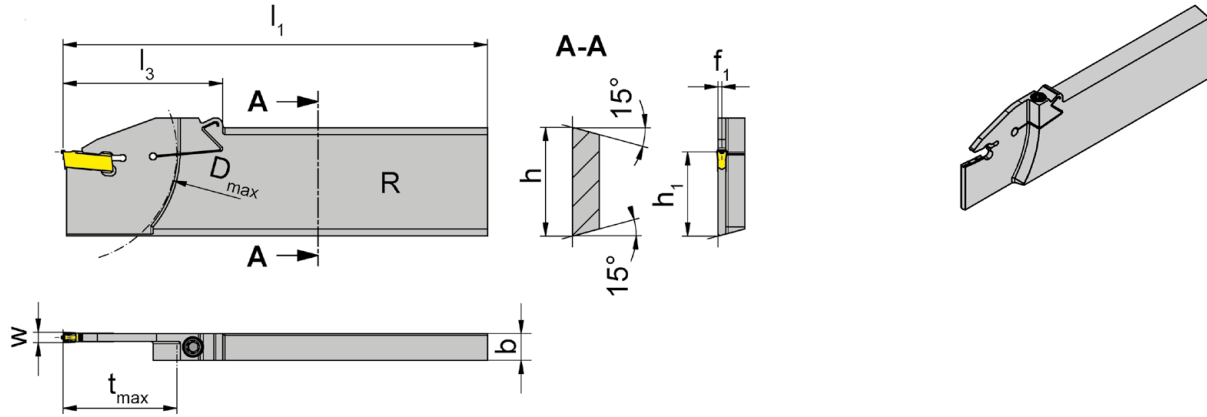
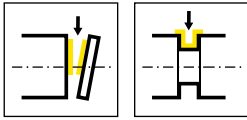

R = rechts wie gezeichnet
R = right hand version shown

L = links spiegelbildlich
L = left hand version

F

Bestellnummer Part number	h	b	l ₁	h ₁	f ₁	l ₃	t _{max}	D _{max}	Maschinentyp Machine type	HWS
RH100.3208.83	32	8	125	24,8	1,15	47	33,5	65	TraubTNX65/42, IndexC65	100038
LH100.3208.83	32	8	125	24,8	1,15	47	33,5	65	TraubTNX65/42, IndexC65	100038
LH100.3208.15.83	32	8	150	24,8	1,15	47	33,5	65	TraubTNX65/42, IndexC65	100038
LH100.3208.84	32	8	125	24,8	1,5	47	33,5	65	TraubTNX65/42, IndexC65	100048

w siehe Schneidplatten
w see inserts

Ersatzteile
Spare Parts

Klemmhalter Toolholder	Spannschraube Clamping Screw	TORX PLUS®-Schlüssel TORX PLUS® Wrench
R/LH100...	030.505P.0718	T15PQ
LH100.3208.15.83	030.505P.0718	T15PL

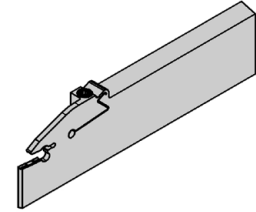
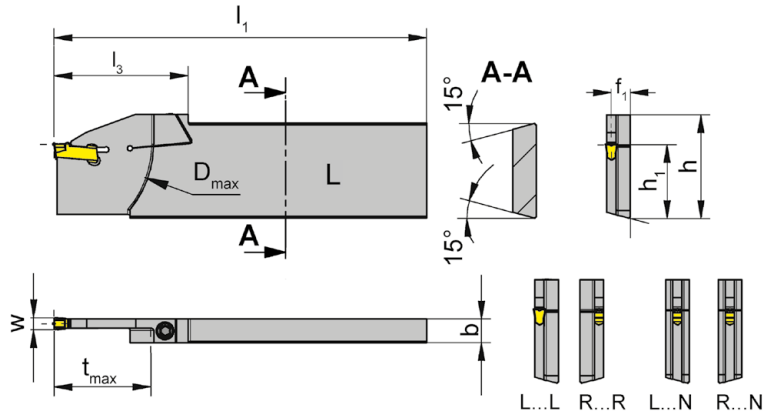
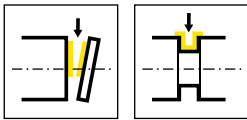

L = links wie gezeichnet
L = left hand version shown

R = rechts spiegelbildlich
R = right hand version

Bestellnummer Part number	h	b	l ₁	h ₁	f ₁	l ₃	t _{max}	D _{max}	Maschinentyp Machine type	HWS
RH100.3208.83R	32	8	125	24,8	6,85	47	33,5	65	TraubTNX65/42, IndexC65	100038
RH100.3208.84R	32	8	125	24,8	6,5	47	33,5	65	TraubTNX65/42, IndexC65	100048
RH100.3208.84N	32	8	134	24,8	4	54,5	41	80	TraubTNX80/65	100048
LH100.3208.83L	32	8	125	24,8	6,85	47	33,5	65	TraubTNX65/42, IndexC65	100038
LH100.3208.83N	32	8	125	24,8	4	47	33,5	65	TraubTNX65/42, IndexC65	100038
LH100.3208.84L	32	8	125	24,8	6,5	47	33,5	65	TraubTNX65/42, IndexC65	100048
LH100.3208.84N	32	8	134	24,8	4	54,5	41	80	TraubTNX80/65	100048

w siehe Schneidplatten
w see inserts

Ersatzteile

Spare Parts

Klemmhalter Toolholder	Spannschraube Clamping Screw	TORX PLUS®-Schlüssel TORX PLUS® Wrench
R/LH100.3208....	030.505P.0718	T15PQ



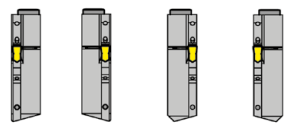
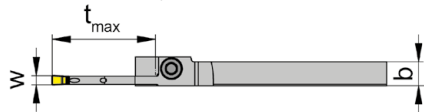
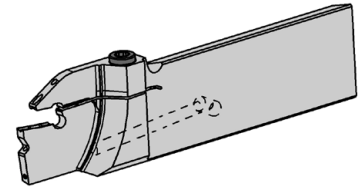
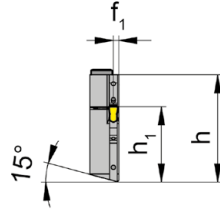
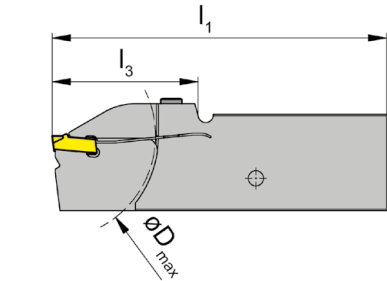
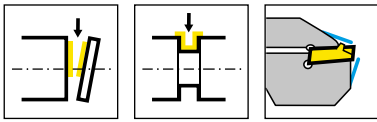

R...IK L...IK R...R.IK L...L.IK

L = links wie gezeichnet
L = left hand version shown

R = rechts spiegelbildlich
R = right hand version

F

Bestellnummer Part number	h	b	l ₁	h ₁	f ₁	l ₃	t _{max}	D _{max}	HWS
RH100.2608.26.4.73.IK	26	7,9	110	21,4	1,8	40	25	50	100038
RH100.2608.26.4.73R.IK	26	7,9	110	21,4	6,55	40	25	50	100038
RH100.3208.34.4.73.IK	32	7,9	110	24,8	1,8	48	34	68	100038
RH100.3208.34.4.73R.IK	32	7,9	110	24,8	6,55	48	34	68	100038
LH100.2608.26.4.73.IK	26	7,9	110	21,4	1,8	40	25	50	100038
LH100.2608.26.4.73L.IK	26	7,9	110	21,4	6,55	40	25	50	100038
LH100.3208.34.4.73.IK	32	7,9	110	24,8	1,8	48	34	68	100038
LH100.3208.34.4.73L.IK	32	7,9	110	24,8	6,55	48	34	68	100038

für TRAUB- und INDEX-Maschinen
for machines TRAUB and INDEX

w siehe Schneidplatten
w see inserts

Ersatzteile

Spare Parts

Klemmhalter Toolholder	Spannschraube Clamping Screw	TORX PLUS®-Schlüssel TORX PLUS® Wrench
R/LH100...	5.13T20P	T20PQ

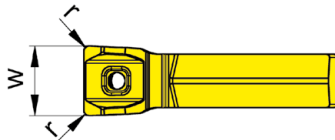
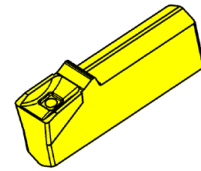
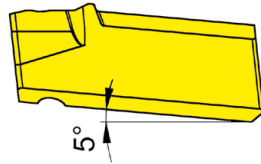
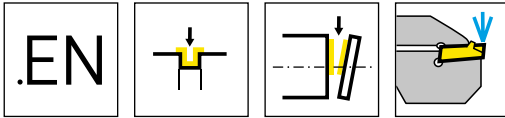

▲ ab Lager
on stock

△ 4 Wochen
4 weeks

HM-Sorten
Carbide grades

Bestellnummer Part number	w	r	HIS	HM-Sorten Carbide grades		
				AS45	EG55	HP65
S100.0250.EN2.IK	2,5	0,2	100029	▲	△	▲
S100.0300.EN2.IK	3	0,2	100039	▲	▲	▲
S100.0400.EN3.IK	4	0,3	100049	▲	▲	▲
P	●	●	●	●	●	●
M	●	○	●	●	○	●
K	●	○	●	●	○	●
N	○	-	○	○	-	○
S	●	-	●	●	-	●
H	-	-	-	-	-	-



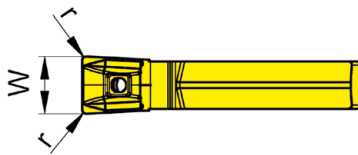
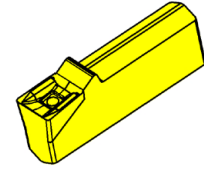
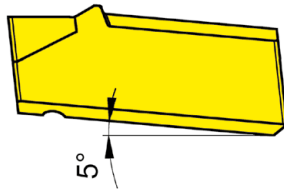
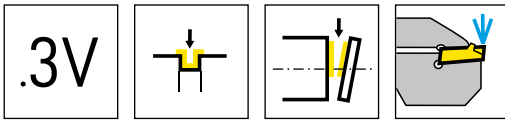

HM-Sorten
Carbide grades
▲ ab Lager
on stock
△ 4 Wochen
4 weeks

▲ ab Lager
on stock

△ 4 Wochen
4 weeks

Bestellnummer Part number	w	r	HIS	HP65	IG35
S100.0250.3V2.IK	2,5	0,2	100029	▲	▲
S100.0300.3V2.IK	3	0,2	100039	▲	▲
				P ● -	
				M ● ●	
				K ● -	
				N ○ -	
				S ● ●	
				H - -	

F

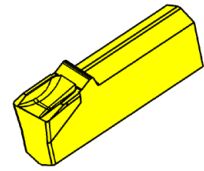
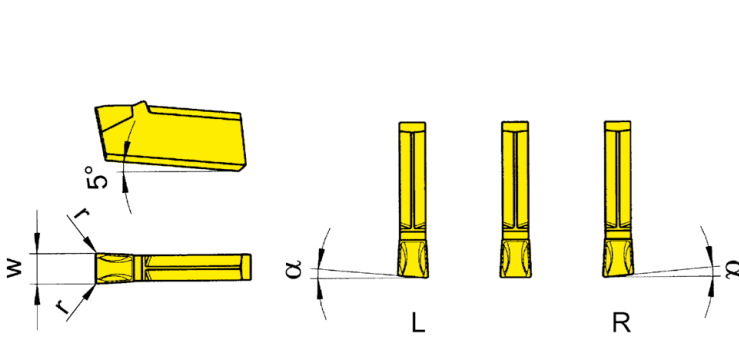
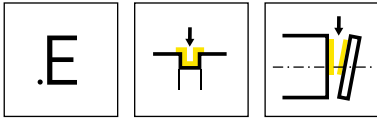

R = Rechtsausführung
R = right hand version

L = Linksausführung
L = left hand version

▲ ab Lager
on stock

HM-Sorten
Carbide grades
Δ 4 Wochen
4 weeks

Bestellnummer Part number	w	r	α	HIS	ALX2	ALX3	AS63	AS66	TC92	TC93	TF42	TF43	TF45	TF46
RS100.0520.E2	2	0,2	5°	100018					Δ			▲	▲	Δ
RS100.0525.E2	2,5	0,2	5°	100028					Δ	▲		▲	▲	Δ
RS100.0530.E2	3	0,2	5°	100038		▲			Δ	Δ	▲	▲	▲	▲
RS100.0540.E2	4	0,2	5°	100048		Δ			Δ	Δ		▲	▲	Δ
LS100.0520.E2	2	0,2	5°	100018					Δ	Δ		Δ	▲	Δ
LS100.0525.E2	2,5	0,2	5°	100028					Δ	Δ		Δ	Δ	Δ
LS100.0530.E2	3	0,2	5°	100038		▲			▲	Δ	Δ	▲	▲	▲
LS100.0540.E2	4	0,2	5°	100048		Δ			Δ	Δ		▲	▲	Δ
S100.0200.E2	2	0,2	0°	100018		▲				Δ		▲	▲	▲
S100.0250.E2	2,5	0,2	0°	100028					Δ			▲	▲	▲
S100.0300.E2	3	0,2	0°	100038	Δ	▲	▲	▲	▲	▲	▲	▲	▲	▲
S100.0400.E3	4	0,3	0°	100048		▲				▲		▲	▲	▲
S100.0500.E3	5	0,3	0°	100058				Δ	Δ	▲		▲	▲	▲
P	●	●	●	●	●	●	●	●	●	●	●	●	●	●
M	-	-	-	O	-	-	-	-	-	-	-	●	●	O
K	-	-	-	●	-	-	-	-	-	-	-	-	-	●
N	-	-	-	●	-	-	-	-	-	-	-	-	●	●
S	-	-	-	O	-	-	-	-	-	-	-	-	●	O
H	-	-	-	-	-	-	-	-	-	-	-	-	-	-



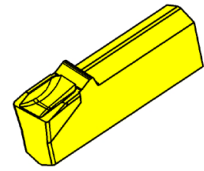
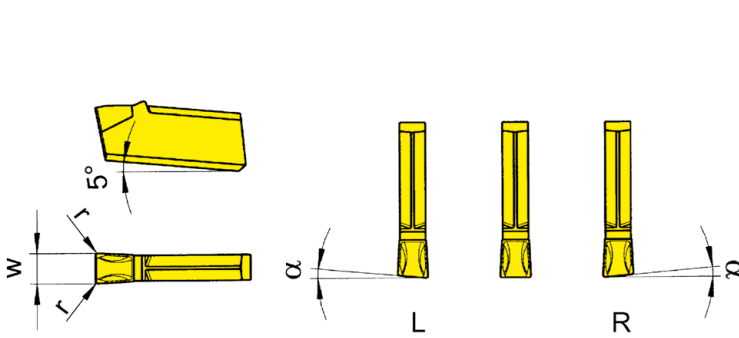
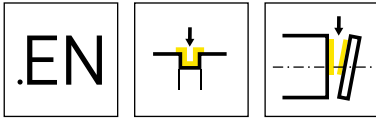

R = Rechtsausführung
R = right hand version

L = Linksausführung
L = left hand version

▲ ab Lager
on stock

HM-Sorten
Carbide grades
Δ 4 Wochen
4 weeks

Bestellnummer Part number	w	r	α	HIS	HM-Sorten Carbide grades							
					ALX3	ALX5	AS62	AS63	AS66	AS6G	TF45	
RS100.0530.EN2	3	0,2	5°	100038			▲		▲			
RS100.0540.EN2	4	0,2	5°	100048	▲							
LS100.0540.EN2	4	0,2	5°	100048	▲							
S100.0200.EN2	2	0,2	0°	100018	▲	Δ					▲	
S100.0220.EN2	2,2	0,2	0°	100018							▲	
S100.0250.EN2	2,5	0,2	0°	100028							▲	
S100.0300.EN2	3	0,2	0°	100038	▲	Δ		▲	▲		▲	Δ
S100.0400.EN3	4	0,3	0°	100048	▲			▲			▲	
S100.0500.EN3	5	0,3	0°	100058	▲							
P					●	●	●	●	●	●	●	●
M					-	●	-	-	○	●	●	●
K					-	●	-	-	●	●	●	●
N					-	●	-	-	●	●	●	●
S					-	●	-	-	○	●	●	●
H					-	-	-	-	-	-	-	-

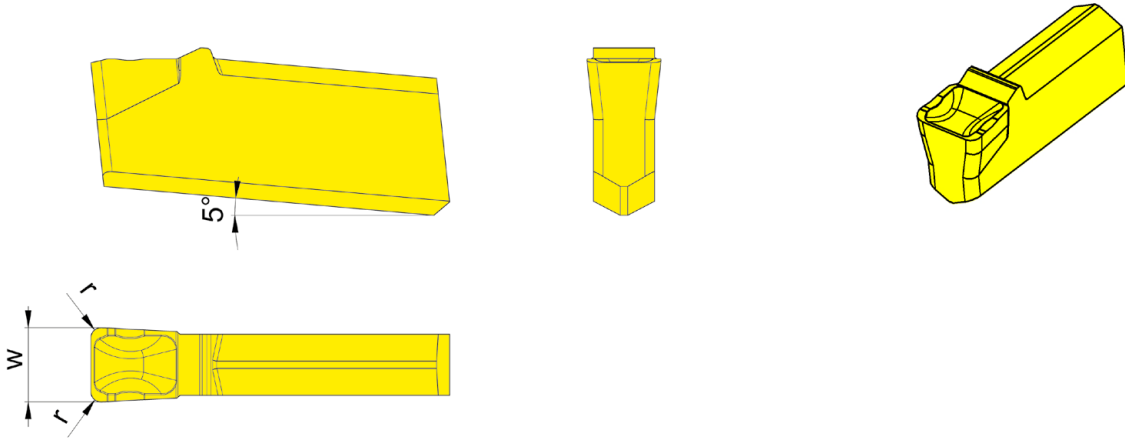
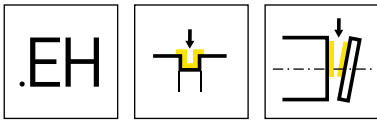

HM-Sorten
Carbide grades

▲ ab Lager
on stock

Δ 4 Wochen
4 weeks

Bestellnummer Part number	w	r	HIS	IG6G
S100.0300.EH4	3	0,4	100038	▲
S100.0400.EH6	4	0,6	100048	▲
				P ●
				M ○
				K ○
				N -
				S -
				H -



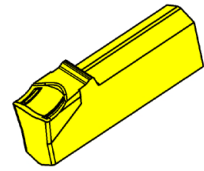
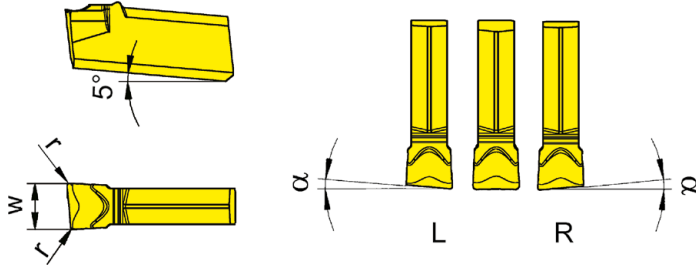
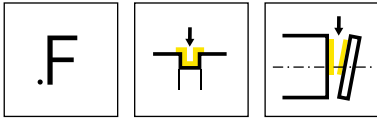

R = rechts wie gezeichnet
R = right hand version shown

L = links spiegelbildlich
L = left hand version

▲ ab Lager
on stock

HM-Sorten
Carbide grades
Δ 4 Wochen
4 weeks

Bestellnummer Part number	w	r	α	HIS	TC92	TC93	TF42	TF43	TF45	TF46	Ti22
RS100.0520.F2	2	0,2	5°	100018	Δ	Δ		Δ	▲	Δ	Δ
RS100.0525.F2	2,5	0,2	5°	100028	Δ	Δ		Δ	▲	Δ	Δ
RS100.0530.F2	3	0,2	5°	100038	Δ	Δ		▲	▲	▲	Δ
RS100.0540.F2	4	0,2	5°	100048	Δ	Δ			▲	Δ	Δ
LS100.0520.F2	2	0,2	5°	100018	Δ	Δ		Δ		Δ	Δ
LS100.0525.F2	2,5	0,2	5°	100028	Δ	Δ		Δ	▲	Δ	Δ
LS100.0530.F2	3	0,2	5°	100038	Δ			Δ	▲		Δ
LS100.0540.F2	4	0,2	5°	100048	Δ	Δ		Δ	▲	Δ	Δ
S100.0200.F2	2	0,2	-	100018	▲	Δ		▲	▲	▲	Δ
S100.0250.F2	2,5	0,2	0°	100028	Δ	Δ			▲	Δ	▲
S100.0300.F2	3	0,2	0°	100038			▲	Δ	▲	▲	Δ
S100.0400.F3	4	0,3	0°	100048	Δ	▲		▲	▲	▲	Δ
S100.0500.F3	5	0,3	0°	100058	Δ			Δ	▲	Δ	Δ
P					●	●	●	●	●	●	●
M					-	-	-	-	●	○	-
K					-	-	-	-	●	●	-
N					-	-	-	-	●	●	-
S					-	-	-	-	●	○	-
H					-	-	-	-	-	-	-

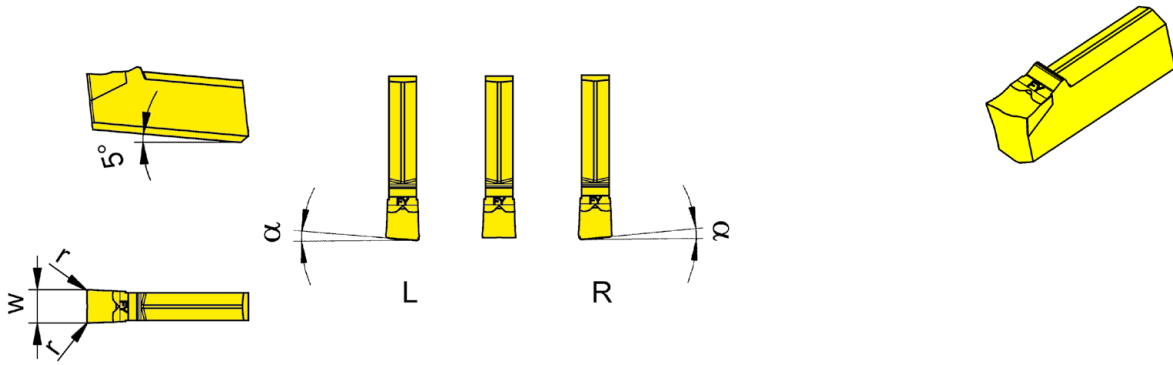
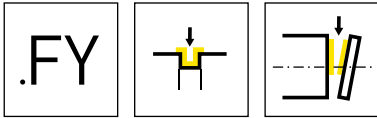

R = Rechtsausführung
R = right hand version

L = Linksausführung
L = left hand version

▲ ab Lager
on stock

HM-Sorten
Carbide grades
Δ 4 Wochen
4 weeks

Bestellnummer Part number	w	r	α	HIS	AS45	HP65	IG35	PH35	TI25
RS100.1520.FY0	2	0	15°	100018	▲		▲		
RS100.1530.FY0	3	-	15°	100038	▲		▲		
LS100.1520.FY0	2	0	15°	100018	▲		▲		
LS100.1530.FY0	3	-	15°	100038	▲		▲		
S100.0200.FY2	2	0,2	-	100018	Δ	▲	▲	Δ	▲
S100.0220.FY2	2,2	0,2	0°	100018			▲		▲
S100.0250.FY2	2,5	0,2	0°	100028	Δ	▲	▲		▲
S100.0300.FY2	3	0,2	0°	100038	Δ	▲	▲		▲
S100.0400.FY3	4	0,3	0°	100048		▲	▲		▲
P	●	●	-	○	●				
M	●	●	●	○	●				
K	●	●	-	●	●				
N	○	○	-	-	●				
S	●	●	●	-	●				
H	-	-	-	-	-				



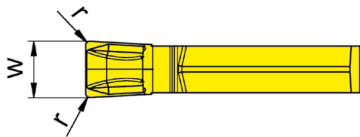
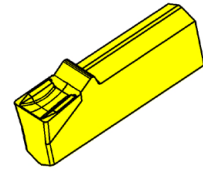
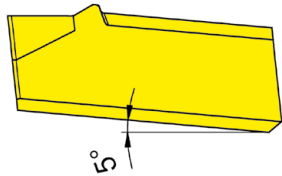
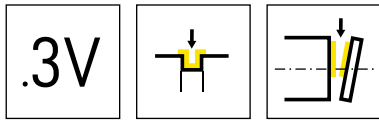

HM-Sorten
Carbide grades

▲ ab Lager
on stock

△ 4 Wochen
4 weeks

F

Bestellnummer Part number	w	r	HIS		AS45	HP35	HP65	IG35	PH35
S100.0200.3V2	2	0,2	100018	▲	▲	△	▲	▲	△
S100.0250.3V2	2,5	0,2	100028	▲	▲	▲	▲	▲	▲
S100.0300.3V2	3	0,2	100038	▲	▲	▲	▲	▲	▲
S100.0400.3V3	4	0,3	100048	▲	▲	▲	▲	▲	▲
P	●	○	●	-	○				
M	●	●	●	●	○				
K	●	○	●	-	●				
N	○	-	○	-	-				
S	●	○	●	●	-				
H	-	-	-	-	-				

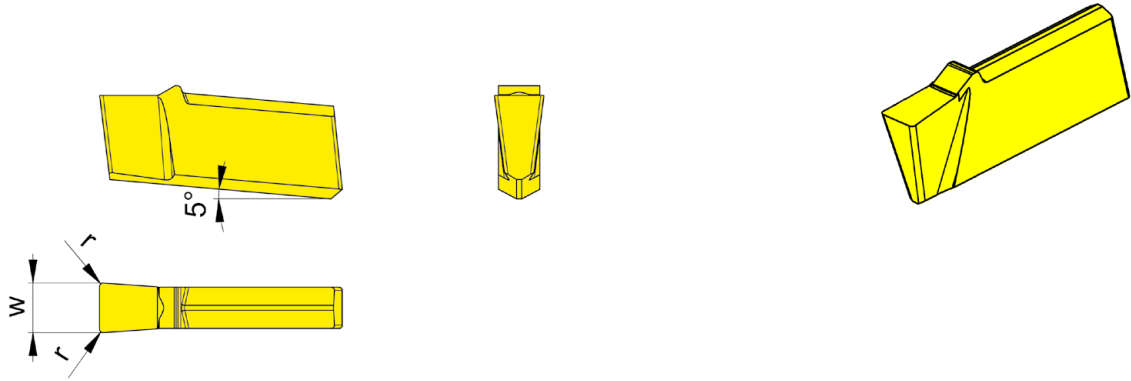
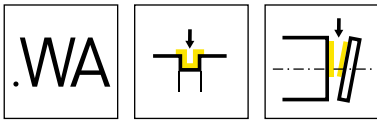

HM-Sorten
Carbide grades

▲ ab Lager
on stock

△ 4 Wochen
4 weeks

Bestellnummer Part number	w	r	HIS	K10	DD26
S100.0200.WA2	2	0,2	100018	▲	▲
S100.0300.WA2	3	0,2	100038	▲	▲
				P ●	-
				M ○	-
				K ●	-
				N ●	●
				S ○	○
				H -	-



Schneidplatte

Insert

S100

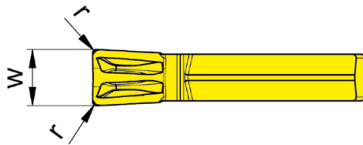
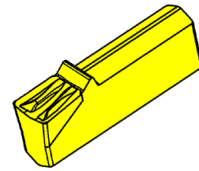
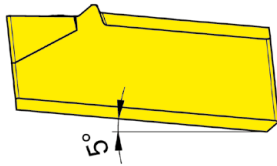
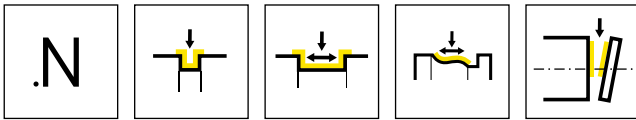

HM-Sorten
Carbide grades

▲ ab Lager
on stock

Δ 4 Wochen
4 weeks

Bestellnummer Part number	w	r	HIS	AS45	HP65
S100.0300.N2	3	0,2	100038	▲	▲
S100.0400.N3	4	0,3	100048	▲	▲
P	●	●			
M	●	●			
K	●	●			
N	o	o			
S	●	●			
H	-	-			

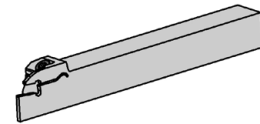
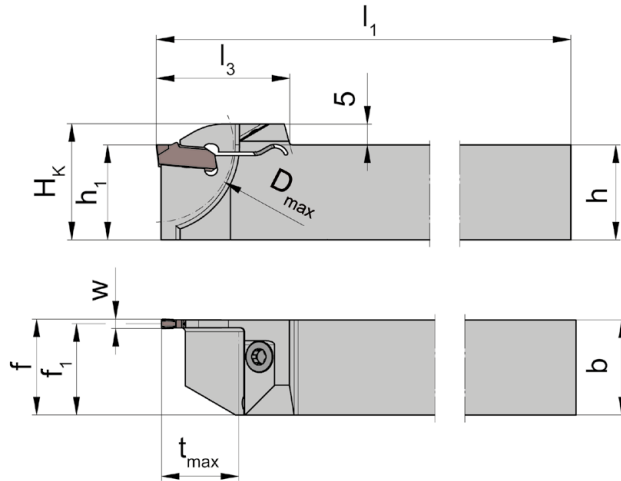
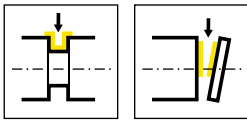

L = links wie gezeichnet
L = left hand version shown

R = rechts spiegelbildlich
R = right hand version

Bestellnummer Part number	h	b	l ₁	l ₃	h ₁	f ₁	f	t _{max}	H _k	D _{max}	HWS
RH101.1010.1.12	10	10	125	22,5	10	9,53	f ₁ +w/2	13	13,5	26	10112
RH101.1212.1.12	12	12	125	22,5	12	11,53	f ₁ +w/2	13	15,5	26	10112
RH101.1616.1.12	16	16	125	22,5	16	15,53	f ₁ +w/2	13	19,5	26	10112
RH101.1010.1.16	10	10	125	22,5	10	9,35	f ₁ +w/2	13	13,5	26	10116
RH101.1212.1.16	12	12	125	22,5	12	11,35	f ₁ +w/2	13	15,5	26	10116
RH101.1616.1.16	16	16	125	22,5	16	15,35	f ₁ +w/2	13	19,5	26	10116
LH101.1010.1.12	10	10	125	22,5	10	9,53	f ₁ +w/2	13	13,5	26	10112
LH101.1212.1.12	12	12	125	22,5	12	11,53	f ₁ +w/2	13	15,5	26	10112
LH101.1616.1.12	16	16	125	22,5	16	15,53	f ₁ +w/2	13	19,5	26	10112
LH101.1010.1.16	10	10	125	22,5	10	9,35	f ₁ +w/2	13	13,5	26	10116
LH101.1212.1.16	12	12	125	22,5	12	11,35	f ₁ +w/2	13	15,5	26	10116
LH101.1616.1.16	16	16	125	22,5	16	15,35	f ₁ +w/2	13	19,5	26	10116

w siehe Schneidplatten
w see inserts

Ersatzteile
Spare Parts

Klemmhalter Toolholder	Spannschraube Clamping Screw	TORX PLUS®-Schlüssel TORX PLUS® Wrench
R/LH101...	3.5.12T10EP	T10PL



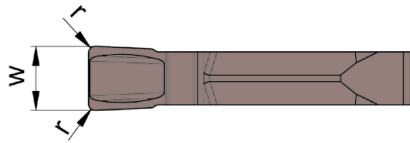
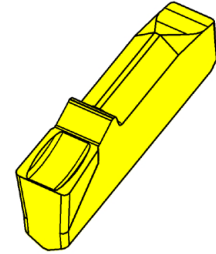
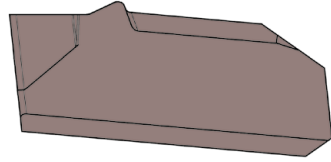
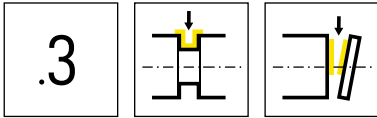

HM-Sorten
Carbide grades

▲ ab Lager
on stock

Δ 4 Wochen
4 weeks

Bestellnummer Part number	w	r	HIS	AS45	IG35
S101.0120.315	1,2	0,15	10112	▲	▲
S101.0160.315	1,6	0,15	10116	▲	▲
				P ●	-
				M ●	●
				K ●	-
				N ○	-
				S ●	●
				H -	-

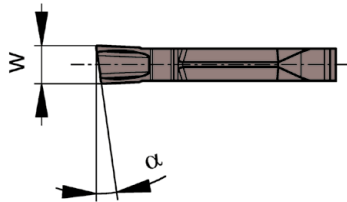
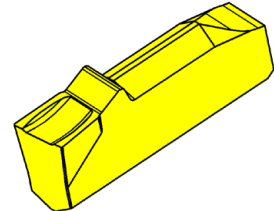
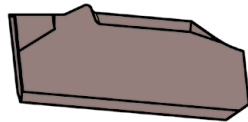
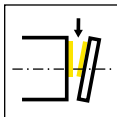
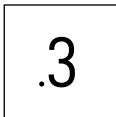

R = rechts wie gezeichnet
R = right hand version shown

L = links spiegelbildlich
L = left hand version

▲ ab Lager
on stock

HM-Sorten
Carbide grades
Δ 4 Wochen
4 weeks

Bestellnummer Part number	w	α	HIS	AS45	EG55	IG35
RS101.0812.30	1,2	8°	10112		▲	▲
RS101.0816.30	1,6	8°	10116	▲		▲
RS101.0820.30	2	8°	10120	▲		▲
RS101.0825.30	2,5	8°	10120	▲		▲
LS101.0812.30	1,2	8°	10112		▲	▲
LS101.0816.30	1,6	8°	10116	▲		▲
LS101.0820.30	2	8°	10120	▲		▲
LS101.0825.30	2,5	8°	10120	▲		▲
P	●	●	-			
M	●	○	●			
K	●	○	-			
N	○	-	-			
S	●	-	●			
H	-	-	-			



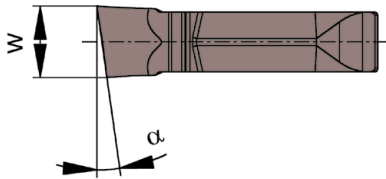
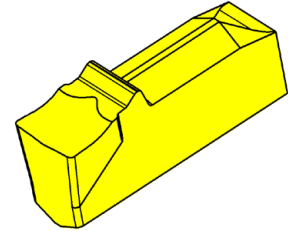
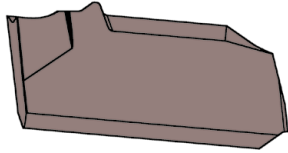
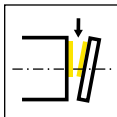

R = rechts wie gezeichnet
R = right hand version shown

L = links spiegelbildlich
L = left hand version

▲ ab Lager
on stock

HM-Sorten
Carbide grades
Δ 4 Wochen
4 weeks

F

Bestellnummer Part number	w	α	HIS	AS45	IG35
RS101.0830.FY0	3	8°	10130	▲	▲
LS101.0830.FY0	3	8°	10130	▲	▲
				P ● -	
				M ● ●	
				K ● -	
				N ○ -	
				S ● ●	
				H - -	

224



G

**Klemmhalter und
Schneidplatten**

**Toolholder and
Inserts**

Geometrien und
Vorschübe
Geometries and feed rates

Seite/Page
367-371

Klemmhalter
Toolholder
H224

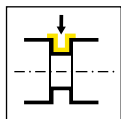

Seite/Page
372-381, 383-
390

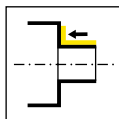

Seite/Page
382

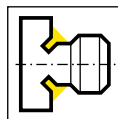

Seite/Page
391

Wendeschneidplatte
Indexable insert
S224

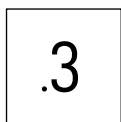

Seite/Page
392

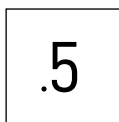

Seite/Page
393

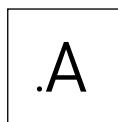

Seite/Page
394

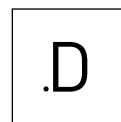

Seite/Page
395

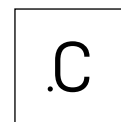

Seite/Page
396



Seite/Page
397

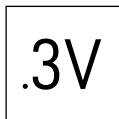

Seite/Page
398, 413

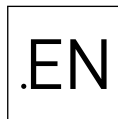

Seite/Page
399

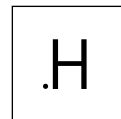

Seite/Page
400

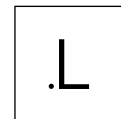

Seite/Page
401



Seite/Page
402

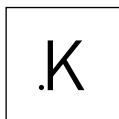

Seite/Page
403



Seite/Page
404



Seite/Page
405

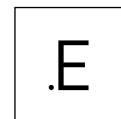

Seite/Page
406



Seite/Page
407



Seite/Page
408

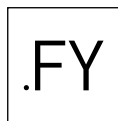

Seite/Page
409

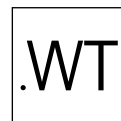

Seite/Page
410



Seite/Page
411



Seite/Page
412

Geometrie Geometry	Werkstoff Material	Vorschubbereich f [mm/U] Feed rate f [mm/rev]	Bearbeitung Machining						
	<table border="1"> <tr> <td>P</td> <td>M</td> <td>K</td> </tr> <tr> <td>N</td> <td>S</td> <td>H</td> </tr> </table>	P	M	K	N	S	H	<p>↓ 0,15-0,25</p> <p>↔ 0,15-0,40</p>	
P	M	K							
N	S	H							
	<table border="1"> <tr> <td>P</td> <td>M</td> <td>K</td> </tr> <tr> <td>N</td> <td>S</td> <td>H</td> </tr> </table>	P	M	K	N	S	H	<p>↓ 0,10-0,45</p> <p>↔ 0,15-0,60</p>	
P	M	K							
N	S	H							
	<table border="1"> <tr> <td>P</td> <td>M</td> <td>K</td> </tr> <tr> <td>N</td> <td>S</td> <td>H</td> </tr> </table>	P	M	K	N	S	H	<p>↓ 0,05-0,30</p> <p>↔ 0,10-0,30</p>	
P	M	K							
N	S	H							
	<table border="1"> <tr> <td>P</td> <td>M</td> <td>K</td> </tr> <tr> <td>N</td> <td>S</td> <td>H</td> </tr> </table>	P	M	K	N	S	H	<p>↓ 0,02-0,10</p>	
P	M	K							
N	S	H							
	<table border="1"> <tr> <td>P</td> <td>M</td> <td>K</td> </tr> <tr> <td>N</td> <td>S</td> <td>H</td> </tr> </table>	P	M	K	N	S	H	<p>↓ 0,03-0,15</p> <p>↔ 0,05-0,20</p>	
P	M	K							
N	S	H							

G

Geometrie Geometry	Werkstoff Material	Vorschubbereich f [mm/U] Feed rate f [mm/rev]	Bearbeitung Machining						
	<table border="1"> <tr> <td>P</td> <td>M</td> <td>K</td> </tr> <tr> <td>N</td> <td>S</td> <td>H</td> </tr> </table>	P	M	K	N	S	H	<p>↓ 0,10-0,22</p> <p>↔ 0,05-0,20</p>	
P	M	K							
N	S	H							
	<table border="1"> <tr> <td>P</td> <td>M</td> <td>K</td> </tr> <tr> <td>N</td> <td>S</td> <td>H</td> </tr> </table>	P	M	K	N	S	H	<p>↓ 0,05-0,20</p>	
P	M	K							
N	S	H							
	<table border="1"> <tr> <td>P</td> <td>M</td> <td>K</td> </tr> <tr> <td>N</td> <td>S</td> <td>H</td> </tr> </table>	P	M	K	N	S	H	<p>↓ 0,10-0,45</p>	
P	M	K							
N	S	H							
	<table border="1"> <tr> <td>P</td> <td>M</td> <td>K</td> </tr> <tr> <td>N</td> <td>S</td> <td>H</td> </tr> </table>	P	M	K	N	S	H	<p>↓ 0,15-0,25</p> <p>↔ 0,10-0,25</p>	
P	M	K							
N	S	H							
	<table border="1"> <tr> <td>P</td> <td>M</td> <td>K</td> </tr> <tr> <td>N</td> <td>S</td> <td>H</td> </tr> </table>	P	M	K	N	S	H	<p>↓ 0,10-0,22</p> <p>↔ 0,05-0,20</p>	
P	M	K							
N	S	H							

G

Geometrien und Vorschübe

Geometries and feed rates



Geometrie Geometry	Werkstoff Material	Vorschubbereich f [mm/U] Feed rate f [mm/rev]	Bearbeitung Machining						
	<table border="1"> <tr> <td>P</td> <td>M</td> <td>K</td> </tr> <tr> <td>N</td> <td>S</td> <td>H</td> </tr> </table>	P	M	K	N	S	H	<p>↓ 0,07-0,25</p>	
P	M	K							
N	S	H							
	<table border="1"> <tr> <td>P</td> <td>M</td> <td>K</td> </tr> <tr> <td>N</td> <td>S</td> <td>H</td> </tr> </table>	P	M	K	N	S	H	<p>↓ 0,05-0,25</p> <p>↔ 0,05-0,25</p>	
P	M	K							
N	S	H							
	<table border="1"> <tr> <td>P</td> <td>M</td> <td>K</td> </tr> <tr> <td>N</td> <td>S</td> <td>H</td> </tr> </table>	P	M	K	N	S	H	<p>↓ 0,10-0,45</p> <p>↔ 0,05-0,25</p>	
P	M	K							
N	S	H							
	<table border="1"> <tr> <td>P</td> <td>M</td> <td>K</td> </tr> <tr> <td>N</td> <td>S</td> <td>H</td> </tr> </table>	P	M	K	N	S	H	<p>↓ 0,02-0,10</p> <p>↔ 0,02-0,15</p>	
P	M	K							
N	S	H							
	<table border="1"> <tr> <td>P</td> <td>M</td> <td>K</td> </tr> <tr> <td>N</td> <td>S</td> <td>H</td> </tr> </table>	P	M	K	N	S	H	<p>↓ 0,08-0,30</p>	
P	M	K							
N	S	H							

G

Geometrie Geometry	Werkstoff Material	Vorschubbereich f [mm/U] Feed rate f [mm/rev]	Bearbeitung Machining						
	<table border="1"> <tr> <td>P</td> <td>M</td> <td>K</td> </tr> <tr> <td>N</td> <td>S</td> <td>H</td> </tr> </table>	P	M	K	N	S	H	<p>↓ 0,03-0,15</p>	
P	M	K							
N	S	H							
	<table border="1"> <tr> <td>P</td> <td>M</td> <td>K</td> </tr> <tr> <td>N</td> <td>S</td> <td>H</td> </tr> </table>	P	M	K	N	S	H	<p>↓ 0,02-0,10 ↔ 0,0015-0,07</p>	
P	M	K							
N	S	H							
	<table border="1"> <tr> <td>P</td> <td>M</td> <td>K</td> </tr> <tr> <td>N</td> <td>S</td> <td>H</td> </tr> </table>	P	M	K	N	S	H	<p>↓ 0,03-0,15</p>	
P	M	K							
N	S	H							
	<table border="1"> <tr> <td>P</td> <td>M</td> <td>K</td> </tr> <tr> <td>N</td> <td>S</td> <td>H</td> </tr> </table>	P	M	K	N	S	H	<p>↓ 0,06-0,08 ↔ 0,06-0,08</p>	
P	M	K							
N	S	H							
	<table border="1"> <tr> <td>P</td> <td>M</td> <td>K</td> </tr> </table>	P	M	K	<p>↓ 0,05-0,15</p>				
P	M	K							

G

Geometrie
Geometry

Werkstoff
Material

Vorschubbereich f [mm/U]
Feed rate f [mm/rev]

Bearbeitung
Machining

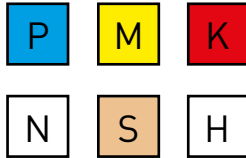

↔ 0,05-0,2

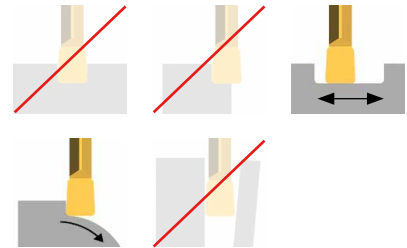

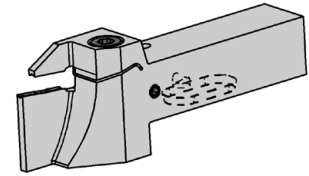
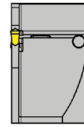
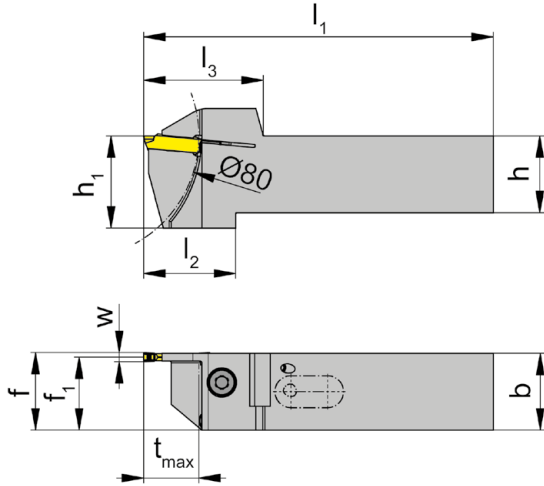
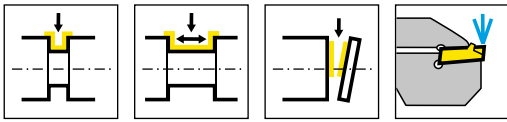

L = links wie gezeichnet
L = left hand version shown

R = rechts spiegelbildlich
R = right hand version

Bestellnummer Part number	h	b	l ₁	l ₂	l ₃	h ₁	f ₁	f	t _{max}	HWS
RH224.1616.3.23.IK	16	16	87	33	39	25	14,75	f ₁ +w/2	18	224039
RH224.2020.3.23.IK	20	20	99	30	39	25	18,75	f ₁ +w/2	18	224039
LH224.1616.3.23.IK	16	16	87	33	39	25	14,75	f ₁ +w/2	18	224039
LH224.2020.3.23.IK	20	20	99	30	39	25	18,75	f ₁ +w/2	18	224039

w siehe WSP
w see indexable inserts

Ersatzteile
Spare Parts

Klemmhalter Toolholder	Spannschraube Clamping Screw	TORX PLUS®-Schlüssel TORX PLUS® Wrench
R/LH224...	6.23T25P	T25PQ

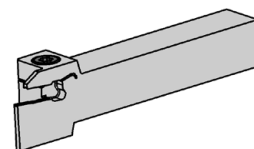
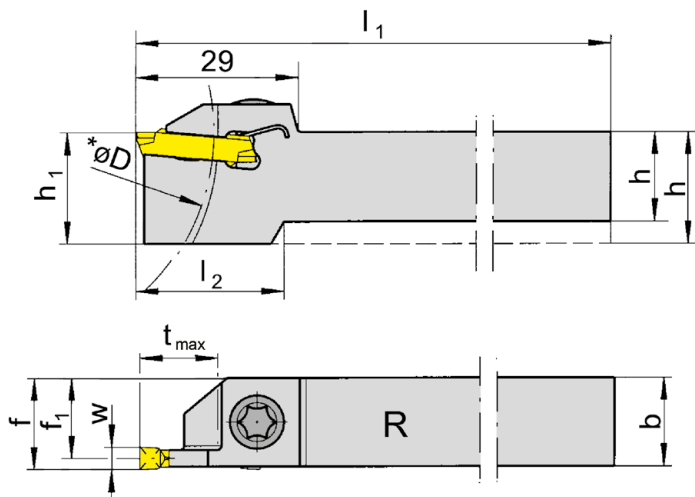
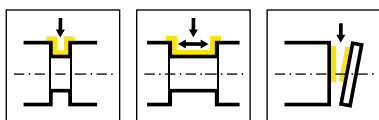

R = rechts wie gezeichnet
R = right hand version shown

L = links spiegelbildlich
L = left hand version

Bestellnummer Part number	h	b	l ₁	l ₂	h ₁	f ₁	f	t _{max}	D _{max}	HWS
RH224.1616.01	16	16	125	25	20	15,3	f ₁ +w/2	14	80	224018
RH224.2020.01	20	20	125	-	20	19,3	f ₁ +w/2	14	80	224018
RH224.1616.02	16	16	125	25	20	15,1	f ₁ +w/2	14	80	224028
RH224.2020.02	20	20	125	-	20	19,1	f ₁ +w/2	14	80	224028
RH224.1616.03	16	16	125	25	20	14,9	f ₁ +w/2	14	80	224038
RH224.2020.03	20	20	125	-	20	18,9	f ₁ +w/2	14	80	224038
LH224.1616.01	16	16	125	25	20	15,3	f ₁ +w/2	14	80	224018
LH224.2020.01	20	20	125	-	20	19,3	f ₁ +w/2	14	80	224018
LH224.1616.02	16	16	125	25	20	15,1	f ₁ +w/2	14	80	224028
LH224.2020.02	20	20	125	-	20	19,1	f ₁ +w/2	14	80	224028
LH224.1616.03	16	16	125	25	20	14,9	f ₁ +w/2	14	80	224038
LH224.2020.03	20	20	125	-	20	18,9	f ₁ +w/2	14	80	224038

w siehe WSP
w see indexable inserts

Ersatzteile

Spare Parts

Klemmhalter Toolholder	Spannschraube Clamping Screw	TORX PLUS®-Schlüssel TORX PLUS® Wrench
R/LH224...	6.23T25P	T25PQ



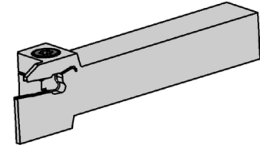
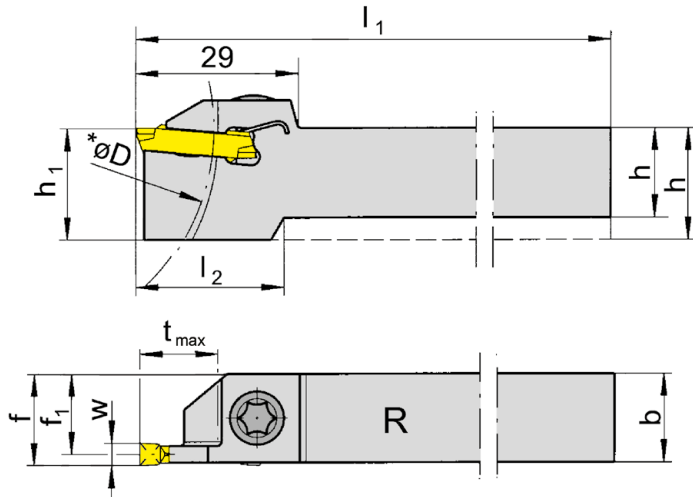
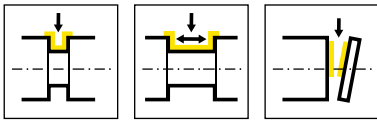

R = rechts wie gezeichnet
R = right hand version shown

L = links spiegelbildlich
L = left hand version

Bestellnummer Part number	h	b	l ₁	l ₂	h ₁	f ₁	f	t _{max}	D _{max}	HWS
RH224.1616.04	16	16	125	25	20	14,55	f ₁ +w/2	14	80	224048
RH224.2020.04	20	20	125	-	20	18,55	f ₁ +w/2	14	80	224048
RH224.1616.05	16	16	125	-	20	18,15	f ₁ +w/2	14	80	224058
RH224.2020.05	20	20	125	-	20	18,15	f ₁ +w/2	14	80	224058
RH224.2020.06	20	20	125	-	20	17,75	f ₁ +w/2	14	80	224068
LH224.1616.04	16	16	125	25	20	14,55	f ₁ +w/2	14	80	224048
LH224.2020.04	20	20	125	-	20	18,55	f ₁ +w/2	14	80	224048
LH224.1616.05	16	16	125	-	20	18,15	f ₁ +w/2	14	80	224058
LH224.2020.05	20	20	125	-	20	18,15	f ₁ +w/2	14	80	224058
LH224.2020.06	20	20	125	-	20	17,75	f ₁ +w/2	14	80	224068

w siehe WSP
w see indexable inserts

Ersatzteile
Spare Parts

Klemmhalter Toolholder	Spannschraube Clamping Screw	TORX PLUS®-Schlüssel TORX PLUS® Wrench
R/LH224...	6.23T25P	T25PQ



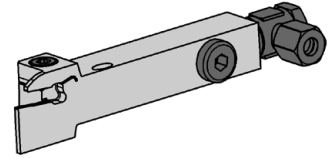
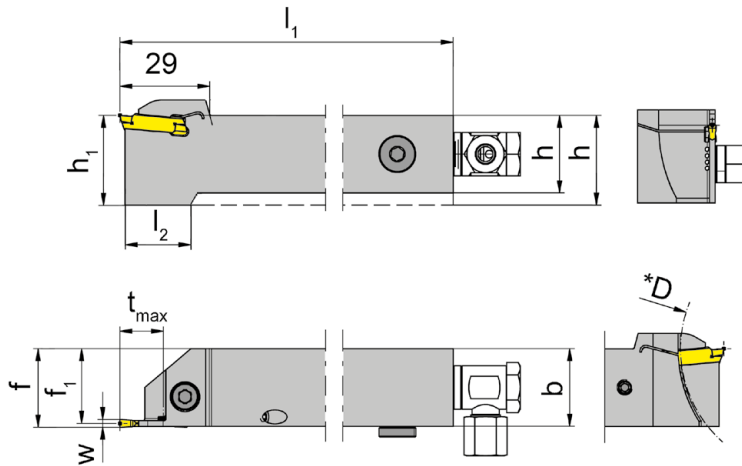
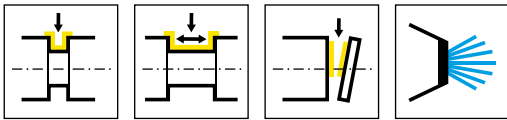

R = rechts wie gezeichnet
R = right hand version shown

L = links spiegelbildlich
L = left hand version

Bestellnummer Part number	h	b	l ₁	l ₂	h ₁	f ₁	f	t _{max}	D _{max}	HWS
RH224.1616.01.IK	16	16	125	25	20	15,3	f ₁ +w/2	14	80	224018
RH224.2020.01.IK	20	20	125	-	20	19,3	f ₁ +w/2	14	80	224018
RH224.1616.02.IK	16	16	125	25	20	15,1	f ₁ +w/2	14	80	224028
RH224.2020.02.IK	20	20	125	-	20	19,1	f ₁ +w/2	14	80	224028
RH224.1616.03.IK	16	16	125	25	20	14,9	f ₁ +w/2	14	80	224038
RH224.2020.03.IK	20	20	125	-	20	18,9	f ₁ +w/2	14	80	224038
LH224.1616.01.IK	16	16	125	25	20	15,3	f ₁ +w/2	14	80	224018
LH224.2020.01.IK	20	20	125	-	20	19,3	f ₁ +w/2	14	80	224018
LH224.1616.02.IK	16	16	125	25	20	15,1	f ₁ +w/2	14	80	224028
LH224.2020.02.IK	20	20	125	-	20	19,1	f ₁ +w/2	14	80	224028
LH224.1616.03.IK	16	16	125	25	20	14,9	f ₁ +w/2	14	80	224038
LH224.2020.03.IK	20	20	125	-	20	18,9	f ₁ +w/2	14	80	224038

w siehe WSP
w see indexable inserts

Ersatzteile

Spare Parts

Klemmhalter Toolholder	Kühlmittelanschluss Coolant supply	Spannschraube Clamping Screw	TORX PLUS®-Schlüssel TORX PLUS® Wrench	Verschlusschraube Screw Plug
R/LH224...	004.00.16	6.23T25P	T25PQ	004.00.26



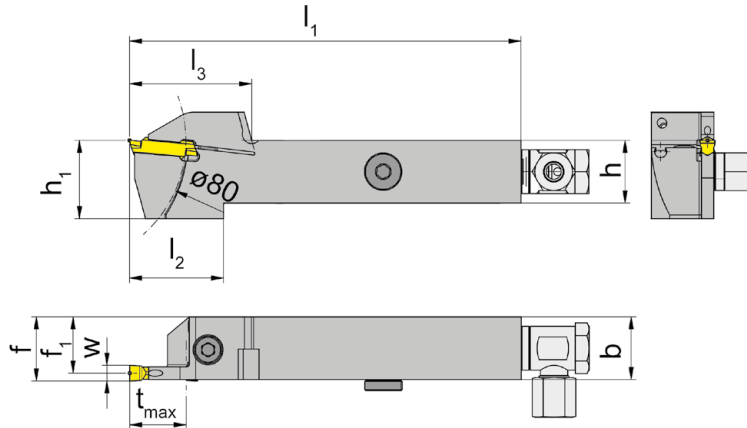
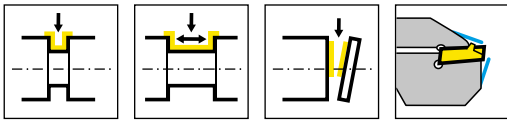

R = rechts wie gezeichnet
R = right hand version shown

L = links spiegelbildlich
L = left hand version

Bestellnummer Part number	h	b	l ₁	l ₂	l ₃	h ₁	f ₁	f	t _{max}	HWS
RH224.1616.0.03.IK	16	16	125	29	35	25	14,75	f ₁ +w/2	14	224038
RH224.2020.0.03.IK	20	20	125	26	35	25	18,75	f ₁ +w/2	14	224038
RH224.1616.0.04.IK	16	16	125	29	35	25	14,3	f ₁ +w/2	14	224048
RH224.2020.0.04.IK	20	20	125	26	35	25	18,3	f ₁ +w/2	14	224048
RH224.1616.0.05.IK	16	16	125	29	35	25	13,95	f ₁ +w/2	14	224058
RH224.2020.0.05.IK	20	20	125	26	35	25	17,95	f ₁ +w/2	14	224058
LH224.1616.0.03.IK	16	16	125	29	35	25	14,75	f ₁ +w/2	14	224038
LH224.2020.0.03.IK	20	20	125	26	35	25	18,75	f ₁ +w/2	14	224038
LH224.1616.0.04.IK	16	16	125	29	35	25	14,3	f ₁ +w/2	14	224048
LH224.2020.0.04.IK	20	20	125	26	35	25	18,3	f ₁ +w/2	14	224048
LH224.1616.0.05.IK	16	16	125	29	35	25	13,95	f ₁ +w/2	14	224058

w siehe WSP
w see indexable inserts

Ersatzteile

Spare Parts

Klemmhalter Toolholder	Kühlmittelanschluss Coolant supply	Spannschraube Clamping Screw	TORX PLUS®-Schlüssel TORX PLUS® Wrench	Verschlusschraube Screw Plug
R/LH224...	004.00.16	6.23T25P	T25PQ	004.00.26

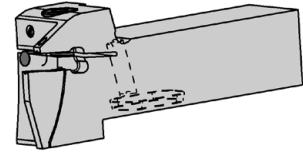
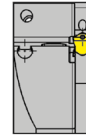
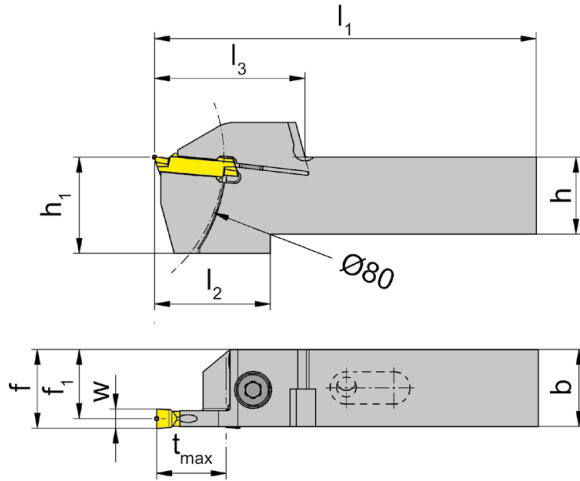
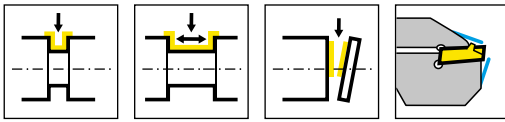

R = rechts wie gezeichnet
R = right hand version shown

L = links spiegelbildlich
L = left hand version

Bestellnummer Part number	h	b	l ₁	l ₂	l ₃	h ₁	f ₁	f	t _{max}	HWS
RH224.1616.2.03.IK	16	16	83	29	35	25	14,75	f ₁ +w/2	14	224038
RH224.1616.2.04.IK	16	16	83	29	35	25	14,3	f ₁ +w/2	14	224048
RH224.2020.2.03.IK	20	20	95	26	35	25	18,75	f ₁ +w/2	14	224038
RH224.2020.2.04.IK	20	20	95	26	35	25	18,3	f ₁ +w/2	14	224048
RH224.2020.2.05.IK	20	20	95	26	35	25	17,95	f ₁ +w/2	14	224058
LH224.1616.2.03.IK	16	16	83	29	35	25	14,75	f ₁ +w/2	14	224038
LH224.1616.2.04.IK	16	16	83	29	35	25	14,3	f ₁ +w/2	14	224048
LH224.1616.2.05.IK	16	16	83	29	35	25	13,95	f ₁ +w/2	14	224058
LH224.2020.2.03.IK	20	20	95	26	35	25	18,75	f ₁ +w/2	14	224038
LH224.2020.2.04.IK	20	20	95	26	35	25	18,3	f ₁ +w/2	14	224048
LH224.2020.2.05.IK	20	20	95	26	35	25	17,95	f ₁ +w/2	14	224058

w siehe WSP
w see indexable inserts

Ersatzteile

Spare Parts

Klemmhalter Toolholder	Spannschraube Clamping Screw	TORX PLUS®-Schlüssel TORX PLUS® Wrench
R/LH224...	6.23T25P	T25PQ



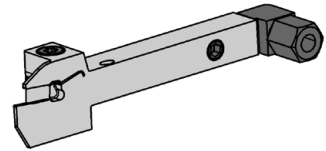
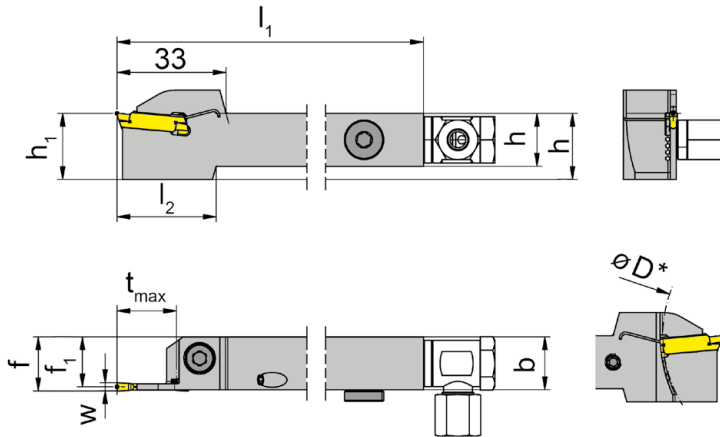
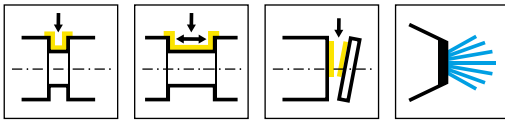

R = rechts wie gezeichnet
R = right hand version shown

L = links spiegelbildlich
L = left hand version

Bestellnummer Part number	h	b	l ₁	l ₂	h ₁	f ₁	f	t _{max}	D _{max}	HWS
RH224.1212.21.IK	12	12	125	33	20	11,3	f ₁ +w/2	18	80	224018
RH224.1616.21.IK	16	16	125	30	20	15,3	f ₁ +w/2	18	80	224018
RH224.2020.21.IK	20	20	125	-	20	19,3	f ₁ +w/2	18	80	224018
RH224.1616.22.IK	16	16	125	30	20	15,1	f ₁ +w/2	18	80	224028
RH224.2020.22.IK	20	20	125	-	20	19,1	f ₁ +w/2	18	80	224028
RH224.1212.23.IK	12	12	125	33	20	10,9	f ₁ +w/2	18	80	224038
RH224.1616.23.IK	16	16	125	30	20	14,9	f ₁ +w/2	18	80	224038
RH224.2020.23.IK	20	20	125	-	20	18,9	f ₁ +w/2	18	80	224038
LH224.1212.21.IK	12	12	125	33	20	11,3	f ₁ +w/2	18	80	224018
LH224.1616.21.IK	16	16	125	30	20	15,3	f ₁ +w/2	18	80	224018
LH224.2020.21.IK	20	20	125	-	20	19,3	f ₁ +w/2	18	80	224018
LH224.1212.22.IK	12	12	125	33	20	11,1	f ₁ +w/2	18	80	224028
LH224.1616.22.IK	16	16	125	30	20	15,1	f ₁ +w/2	18	80	224028
LH224.2020.22.IK	20	20	125	-	20	19,1	f ₁ +w/2	18	80	224028
LH224.1212.23.IK	12	12	125	33	20	10,9	f ₁ +w/2	18	80	224038
LH224.1616.23.IK	16	16	125	30	20	14,9	f ₁ +w/2	18	80	224038
LH224.2020.23.IK	20	20	125	-	20	18,9	f ₁ +w/2	18	80	224038

w siehe WSP
w see indexable inserts

Ersatzteile

Spare Parts

Klemmhalter Toolholder	Kühlmittelanschluss Coolant supply	Spannschraube Clamping Screw	TORX PLUS®-Schlüssel TORX PLUS® Wrench	Verschlusschraube Screw Plug
R/LH224.1212....	004.00.22	6.23T25P	T25PQ	
R/LH224...	004.00.16	6.23T25P	T25PQ	004.00.26

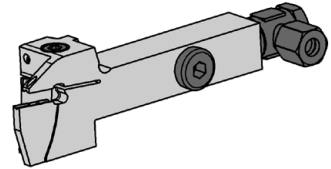
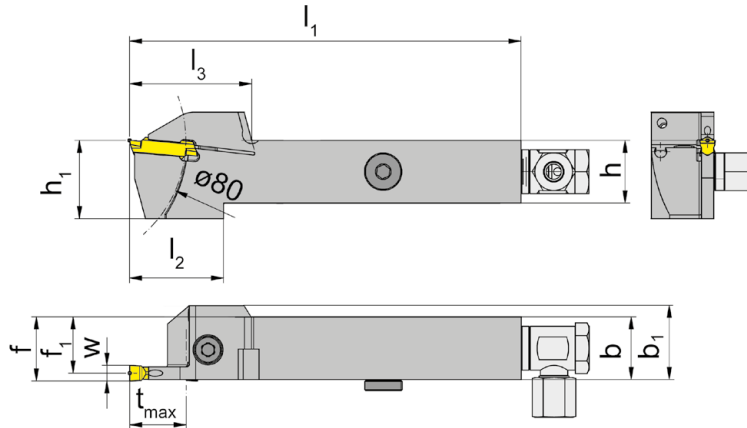
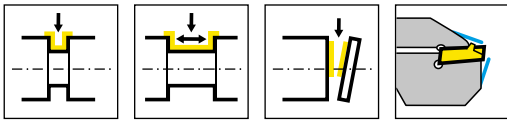

R = rechts wie gezeichnet
R = right hand version shown

L = links spiegelbildlich
L = left hand version

Bestellnummer Part number	h	b	l_1	l_2	l_3	h_1	b_1	f_1	f	t_{max}	HWS
RH224.1616.0.23.IK	16	16	125	33	39	25	20	14,75	$f_1+w/2$	18	224038
RH224.2020.0.23.IK	20	20	125	30	39	25	-	18,75	$f_1+w/2$	18	224038
RH224.1616.0.24.IK	16	16	125	33	39	25	20	14,3	$f_1+w/2$	18	224048
RH224.2020.0.24.IK	20	20	125	30	39	25	-	18,3	$f_1+w/2$	18	224048
RH224.1616.0.25.IK	16	16	125	33	39	25	20	13,95	$f_1+w/2$	18	224058
RH224.2020.0.25.IK	20	20	125	30	39	25	-	17,95	$f_1+w/2$	18	224058
LH224.1616.0.23.IK	16	16	125	33	39	25	20	14,75	$f_1+w/2$	18	224038
LH224.2020.0.23.IK	20	20	125	30	39	25	-	18,75	$f_1+w/2$	18	224038
LH224.1616.0.24.IK	16	16	125	33	39	25	20	14,3	$f_1+w/2$	18	224048
LH224.2020.0.24.IK	20	20	125	30	39	25	-	18,3	$f_1+w/2$	18	224048
LH224.1616.0.25.IK	16	16	125	33	39	25	20	13,95	$f_1+w/2$	18	224058
LH224.2020.0.25.IK	20	20	125	30	39	25	-	17,95	$f_1+w/2$	18	224058

w siehe WSP
w see indexable inserts

Ersatzteile

Spare Parts

Klemmhalter Toolholder	Kühlmittelanschluss Coolant supply	Spannschraube Clamping Screw	TORX PLUS®-Schlüssel TORX PLUS® Wrench	Verschlusschraube Screw Plug
R/LH224...	004.00.16	6.23T25P	T25PQ	004.00.26



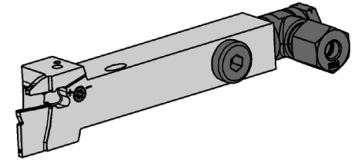
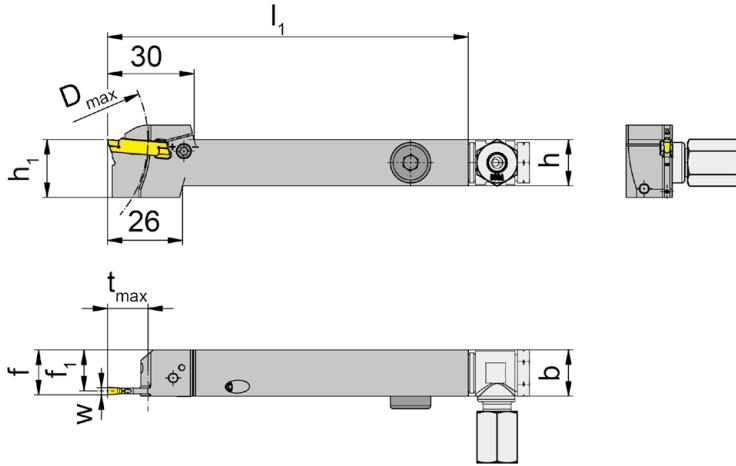
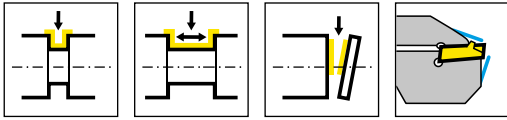

R = rechts wie gezeichnet
R = right hand version shown

L = links spiegelbildlich
L = left hand version

Bestellnummer Part number	h	b	l_1	h_1	f_1	f	D_{max}	t_{max}	HWS
RH224.1616.05.62.IK	16	16	125	16	14,2	$f_1+w/2$	80	14	224028
RH224.1616.05.63.IK	16	16	125	16	14,2	$f_1+w/2$	80	14	224038
LH224.1616.05.62.IK	16	16	125	16	14,2	$f_1+w/2$	80	14	224028
LH224.1616.05.63.IK	16	16	125	16	14,2	$f_1+w/2$	80	14	224038

w siehe WSP
w see indexable inserts

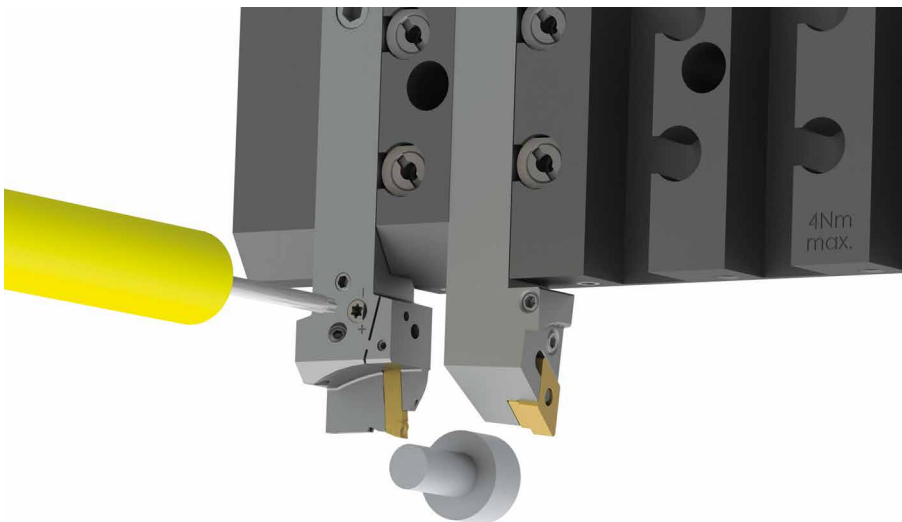

Ersatzteile
Spare Parts

Klemmhalter Toolholder	Kühlmittelanschluss Coolant supply	Verschlusschraube Screw Plug
R/LH224...	004.00.16	004.00.26

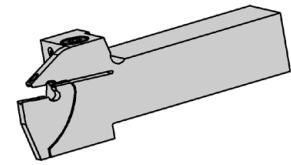
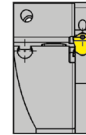
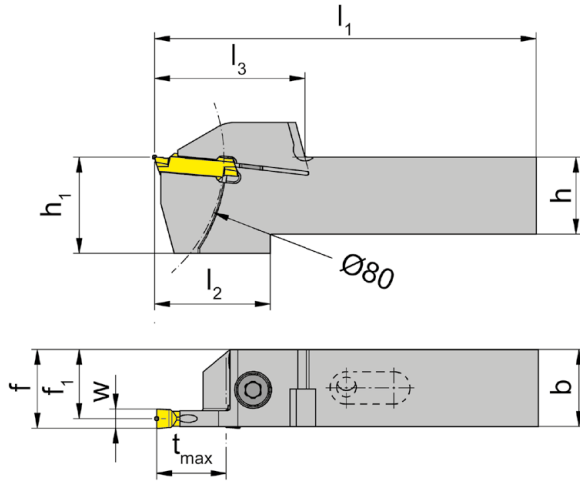
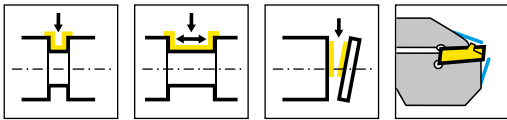

R = rechts wie gezeichnet
R = right hand version shown

L = links spiegelbildlich
L = left hand version

Bestellnummer Part number	h	b	l ₁	l ₂	l ₃	h ₁	f ₁	f	t _{max}	HWS
RH224.1616.2.23.IK	16	16	87	33	39	25	14,75	f ₁ +w/2	18	224038
RH224.1616.2.24.IK	16	16	87	33	39	25	14,3	f ₁ +w/2	18	224048
RH224.1616.2.25.IK	16	16	87	33	39	25	13,95	f ₁ +w/2	18	224058
RH224.2020.2.23.IK	20	20	99	30	39	25	18,75	f ₁ +w/2	18	224038
RH224.2020.2.24.IK	20	20	99	30	39	25	18,3	f ₁ +w/2	18	224048
RH224.2020.2.25.IK	20	20	99	30	39	25	17,95	f ₁ +w/2	18	224058
LH224.1616.2.23.IK	16	16	87	33	39	25	14,75	f ₁ +w/2	18	224038
LH224.1616.2.24.IK	16	16	87	33	39	25	14,3	f ₁ +w/2	18	224048
LH224.1616.2.25.IK	16	16	87	33	39	25	13,95	f ₁ +w/2	18	224058
LH224.2020.2.23.IK	20	20	99	30	39	25	18,75	f ₁ +w/2	18	224038
LH224.2020.2.24.IK	20	20	99	30	39	25	18,3	f ₁ +w/2	18	224048
LH224.2020.2.25.IK	20	20	99	30	39	25	17,95	f ₁ +w/2	18	224058

w siehe WSP
w see indexable inserts

Ersatzteile

Spare Parts

Klemmhalter Toolholder	Spannschraube Clamping Screw	TORX PLUS®-Schlüssel TORX PLUS® Wrench
R/LH224...	6.23T25P	T25PQ



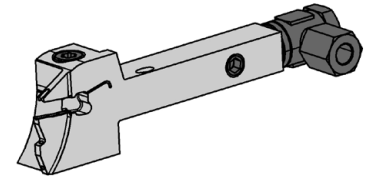
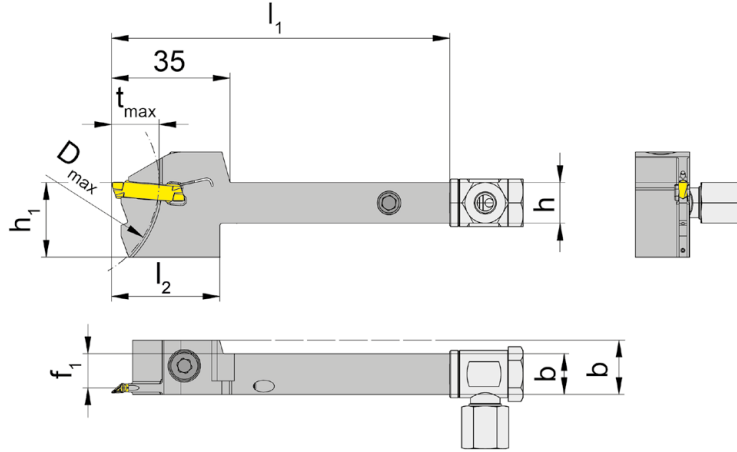
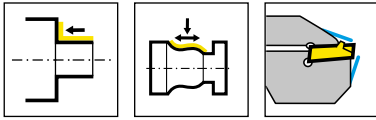

R = rechts wie gezeichnet
R = right hand version shown

L = links wie gezeichnet
L = left hand version shown

Bestellnummer Part number	h	b	l ₁	l ₂	h ₁	b ₁	f ₁	D _{max}	t _{max}	HWS
RH224.1212.S.6.03.IK	12	12	100	32	22	16	10,05	60	14	224038
RH224.1616.S.6.03.IK	16	16	125	29	25	16	14,05	60	14	224038
LH224.1212.S.6.03.IK	12	12	100	32	22	16	10,05	60	14	224038
LH224.1616.S.6.03.IK	16	16	125	29	25	16	14,05	60	14	224038

G

Ersatzteile
Spare Parts

Klemmhalter Toolholder	Kühlmittelanschluss Coolant supply	Spannschraube Clamping Screw	TORX PLUS®-Schlüssel TORX PLUS® Wrench	Verschlusschraube Screw Plug
R/LH224.1212.S.6.03.IK	004.00.22	6.23T25P	T25PQ	
R/LH224.1616.S.6.03.IK	004.00.16	6.23T25P	T25PQ	004.00.26

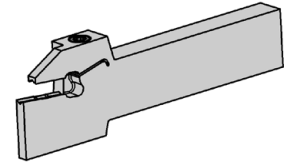
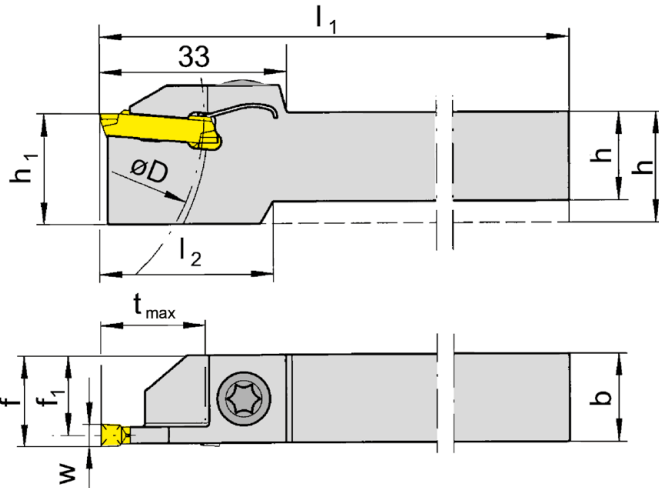
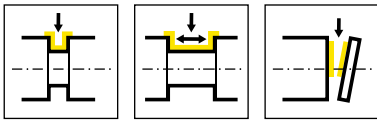

R = rechts wie gezeichnet
R = right hand version shown

L = links spiegelbildlich
L = left hand version

Bestellnummer Part number	h	b	l ₁	l ₂	h ₁	f ₁	f	t _{max}	D _{max}	HWS
RH224.1616.21	16	16	125	30	20	15,3	f ₁ +w/2	18	80	224018
RH224.1212.21	12	12	125	33	20	11,3	f ₁ +w/2	18	80	224018
RH224.2020.21	20	20	125	-	20	19,3	f ₁ +w/2	18	80	224018
RH224.1608.02	16	8	100	30	20	7,1	f ₁ +w/2	14	80	224028
RH224.1616.22	16	16	125	30	20	15,1	f ₁ +w/2	18	80	224028
RH224.2020.22	20	20	125	-	20	19,1	f ₁ +w/2	18	80	224028
RH224.1212.22	12	12	125	33	20	11,1	f ₁ +w/2	18	80	224028
RH224.1608.23	16	8	100	30	20	6,9	f ₁ +w/2	18	80	224038
RH224.1616.23	16	16	125	30	20	14,9	f ₁ +w/2	18	80	224038
RH224.2020.23	20	20	125	-	20	18,9	f ₁ +w/2	18	80	224038
RH224.1212.23	12	12	125	33	20	10,9	f ₁ +w/2	18	80	224038
LH224.1212.21	12	12	125	33	20	11,3	f ₁ +w/2	18	80	224018
LH224.1616.21	16	16	125	30	20	15,3	f ₁ +w/2	18	80	224018
LH224.2020.21	20	20	125	-	20	19,3	f ₁ +w/2	18	80	224018
LH224.1616.22	16	16	125	30	20	15,1	f ₁ +w/2	18	80	224028
LH224.2020.22	20	20	125	-	20	19,1	f ₁ +w/2	18	80	224028
LH224.1212.22	12	12	125	33	20	11,1	f ₁ +w/2	18	80	224028
LH224.1608.23	16	8	100	30	20	6,9	f ₁ +w/2	18	80	224038
LH224.1616.23	16	16	125	30	20	14,9	f ₁ +w/2	18	80	224038
LH224.2020.23	20	20	125	-	20	18,9	f ₁ +w/2	18	80	224038
LH224.1212.23	12	12	125	33	20	10,9	f ₁ +w/2	18	80	224038

w siehe WSP
w see indexable inserts

Ersatzteile

Spare Parts

Klemmhalter Toolholder	Spannschraube Clamping Screw	TORX PLUS®-Schlüssel TORX PLUS® Wrench
R/LH224...	6.23T25P	T25PQ
RH224.1608.02	4.15T15P	T15PL
R/LH224.1608.23	4.15T15P	T15PQ



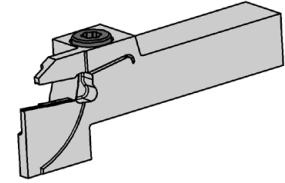
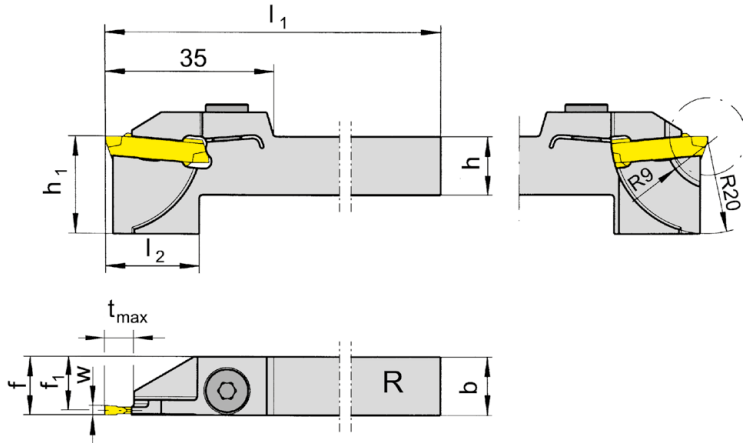
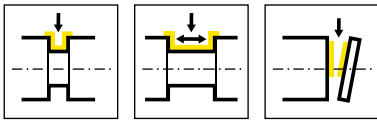

R = rechts wie gezeichnet
R = right hand version shown

Bestellnummer Part number	h	b	l_1	l_2	h_1	f_1	f	t_{max}	HWS
RH224.1212.81	12	12	95	19,5	20	11,1	$f_1+w/2$	8,2	224018

w siehe WSP
w see indexable inserts

G

Ersatzteile
Spare Parts

Klemmhalter Toolholder	Spannschraube Clamping Screw	TORX PLUS®-Schlüssel TORX PLUS® Wrench
RH224.1212.81	6.17T25P	T25PQ

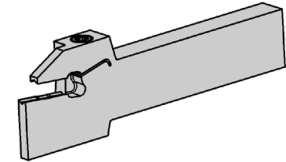
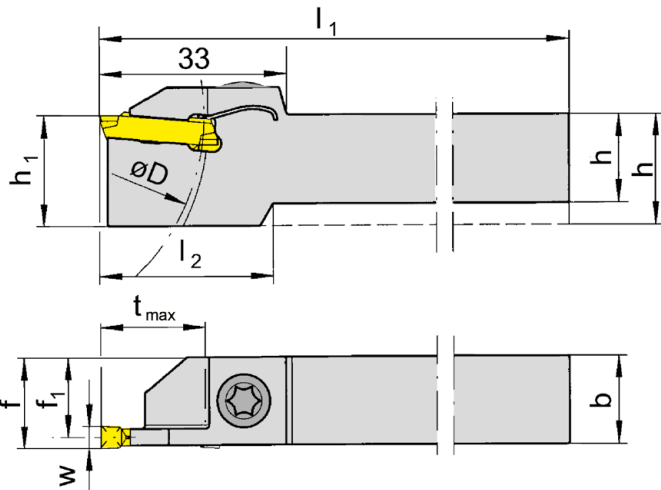
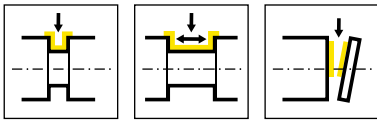

R = rechts wie gezeichnet
R = right hand version shown

L = links spiegelbildlich
L = left hand version

Bestellnummer Part number	h	b	l ₁	h ₁	f ₁	f	t _{max}	D _{max}	HWS
RH224.1616.24	16	16	125	20	14,55	f ₁ +w/2	18	80	224048
RH224.2020.24	20	20	125	20	18,55	f ₁ +w/2	18	80	224048
RH224.1616.25	16	16	125	20	14,15	f ₁ +w/2	18	80	224058
RH224.2020.25	20	20	125	20	18,15	f ₁ +w/2	18	80	224058
RH224.1616.26	16	16	125	20	13,75	f ₁ +w/2	18	80	224068
RH224.2020.26	20	20	125	20	17,75	f ₁ +w/2	18	80	224068
LH224.1608.24	16	8	100	16	6,55	f ₁ +w/2	18	80	224048
LH224.1616.24	16	16	125	20	14,55	f ₁ +w/2	18	80	224048
LH224.2020.24	20	20	125	20	18,55	f ₁ +w/2	18	80	224048
LH224.1616.25	16	16	125	20	14,15	f ₁ +w/2	18	80	224058
LH224.2020.25	20	20	125	20	18,15	f ₁ +w/2	18	80	224058
LH224.1616.26	16	16	125	20	13,75	f ₁ +w/2	18	80	224068
LH224.2020.26	20	20	125	20	17,75	f ₁ +w/2	18	80	224068

w siehe WSP
w see indexable inserts

Ersatzteile
Spare Parts

Klemmhalter Toolholder	Spannschraube Clamping Screw	TORX PLUS®-Schlüssel TORX PLUS® Wrench
LH224.1608.24	4.15T15P	T15PQ
R/LH224...	6.23T25P	T25PQ



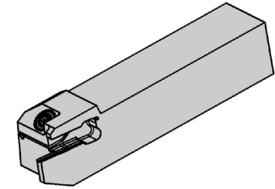
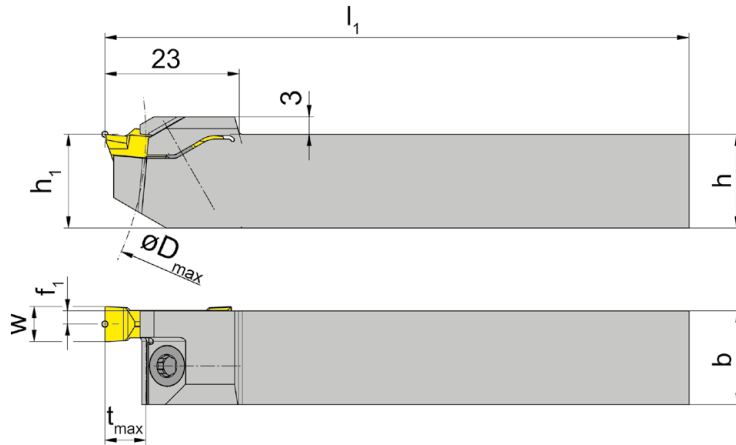
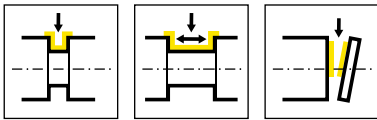

L = links wie gezeichnet
L = left hand version shown

R = rechts spiegelbildlich
R = right hand version

Bestellnummer Part number	h	b	l ₁	h ₁	f ₁	t _{max}	D _{max}	HWS
RH224.1212.61	12	12	100	12	0,7	7	100	224018
RH224.1616.61	16	16	100	16	0,7	7	100	224018
RH224.2020.61	20	20	100	20	0,7	7	100	224018
RH224.1212.62	12	12	100	12	0,9	7	100	224028
RH224.1616.62	16	16	100	16	0,9	7	100	224028
RH224.1212.63	12	12	100	12	1,1	7	100	224038
RH224.1616.63	16	16	100	16	1,1	7	100	224038
RH224.2020.62	20	20	100	20	0,9	7	100	224028
RH224.1212.64	12	12	100	12	1,45	7	100	224048
RH224.1616.64	16	16	100	16	1,45	7	100	224048
RH224.2020.63	20	20	100	20	1,1	7	100	224038
RH224.2020.64	20	20	100	20	1,45	7	100	224048
LH224.1212.61	12	12	100	12	0,7	7	100	224018
LH224.1616.61	16	16	100	16	0,7	7	100	224018
LH224.2020.61	20	20	100	20	0,7	7	100	224018
LH224.1212.62	12	12	100	12	0,9	7	100	224028
LH224.1212.63	12	12	100	12	1,1	7	100	224038
LH224.2020.62	20	20	100	20	0,9	7	100	224028
LH224.1616.63	16	16	100	16	1,1	7	100	224038
LH224.1212.64	12	12	100	12	1,45	7	100	224048
LH224.1616.64	16	16	100	16	1,45	7	100	224048
LH224.2020.63	20	20	100	20	1,1	7	100	224038
LH224.2020.64	20	20	100	20	1,45	7	100	224048

w siehe WSP
w see indexable inserts

Ersatzteile

Spare Parts

Klemmhalter Toolholder	Spannschraube Clamping Screw	TORX PLUS®-Schlüssel TORX PLUS® Wrench
R/LH224...	4.12T15EP	T15PL

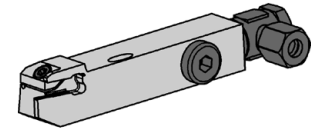
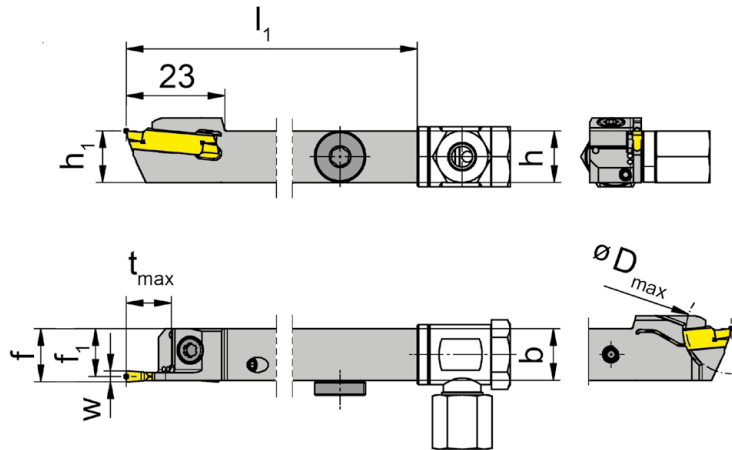
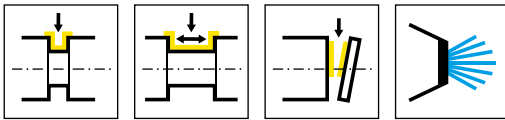

R = rechts wie gezeichnet
R = right hand version shown

L = links spiegelbildlich
L = left hand version

Bestellnummer Part number	h	b	l ₁	h ₁	f ₁	f	t _{max}	D _{max}	HWS
RH224.1212.61.IK	12	12	100	12	0,7	f ₁ +w/2	7	100	224018
RH224.1616.61.IK	16	16	100	16	0,7	f ₁ +w/2	7	100	224018
RH224.2020.61.IK	20	20	100	20	0,7	f ₁ +w/2	7	100	224018
RH224.1212.62.IK	12	12	100	12	0,9	f ₁ +w/2	7	100	224028
RH224.1616.62.IK	16	16	100	16	0,9	f ₁ +w/2	7	100	224028
RH224.1212.63.IK	12	12	100	12	1,1	f ₁ +w/2	7	100	224038
RH224.1616.63.IK	16	16	100	16	1,1	f ₁ +w/2	7	100	224038
RH224.2020.63.IK	20	20	100	20	1,1	f ₁ +w/2	7	100	224038
LH224.1212.61.IK	12	12	100	12	0,7	f ₁ +w/2	7	100	224018
LH224.1616.61.IK	16	16	100	16	0,7	f ₁ +w/2	7	100	224018
LH224.2020.61.IK	20	20	100	20	0,7	f ₁ +w/2	7	100	224018
LH224.1616.62.IK	16	16	100	16	0,9	f ₁ +w/2	7	100	224028
LH224.1212.63.IK	12	12	100	12	1,1	f ₁ +w/2	7	100	224038
LH224.1616.63.IK	16	16	100	16	1,1	f ₁ +w/2	7	100	224038
LH224.2020.63.IK	20	20	100	20	1,1	f ₁ +w/2	7	100	224038

w siehe WSP
w see indexable inserts

Ersatzteile

Spare Parts

Klemmhalter Toolholder	Spannschraube Clamping Screw	Kühlmittelanschluss Coolant supply	TORX PLUS®-Schlüssel TORX PLUS® Wrench	Verschlusschraube Screw Plug
R/LH224.1212...	4.12T15EP	004.00.22	T15PQ	
R/LH224...	4.12T15EP	004.00.16	T15PQ	004.00.26



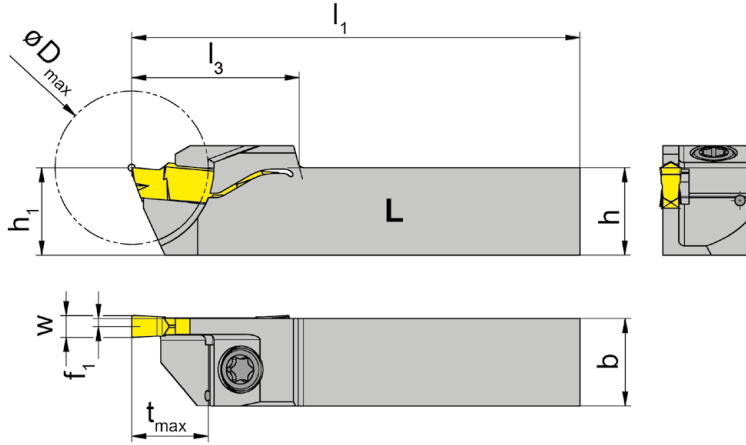
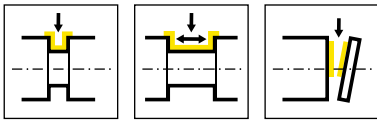

L = links wie gezeichnet
L = left hand version shown

R = rechts spiegelbildlich
R = right hand version

Bestellnummer Part number	h	b	l ₁	l ₃	h ₁	f ₁	t _{max}	D _{max}	HWS
RH224.1212.20.61	12	12	100	23	12	0,7	10,5	21	224018
RH224.1212.20.62	12	12	100	23	12	0,9	10,5	21	224028
RH224.1212.20.63	12	12	100	23	12	1,1	10,5	21	224038
LH224.1212.20.61	12	12	100	23	12	0,7	10,5	21	224018
LH224.1212.20.62	12	12	100	23	12	0,9	10,5	21	224028
LH224.1212.20.63	12	12	100	23	12	1,1	10,5	21	224038

w siehe WSP
w see indexable inserts

Ersatzteile
Spare Parts

Klemmhalter Toolholder	Spannschraube Clamping Screw	TORX PLUS®-Schlüssel TORX PLUS® Wrench
R/LH224...	4.12T15EP	T15PQ

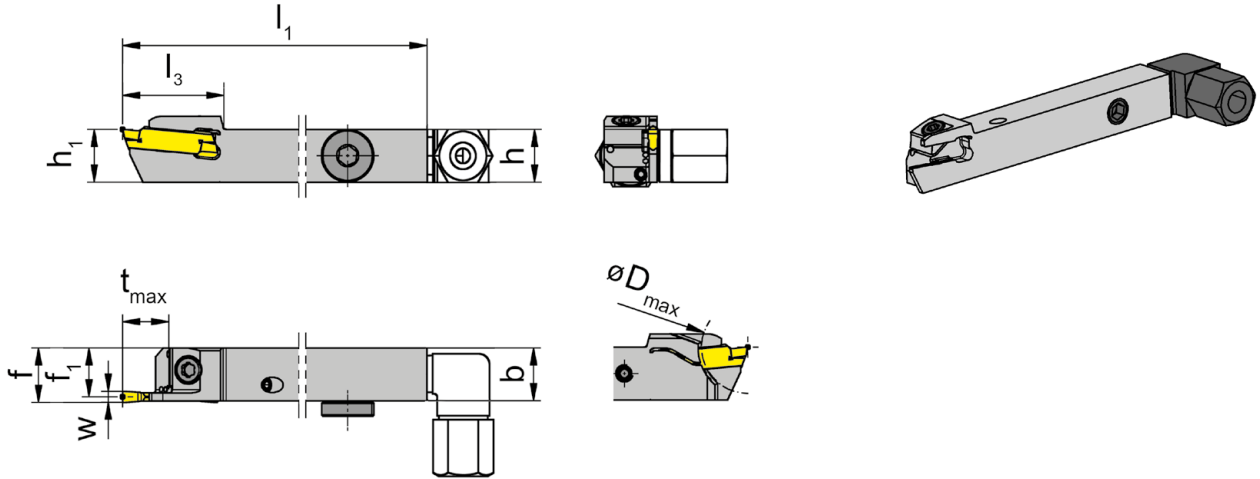
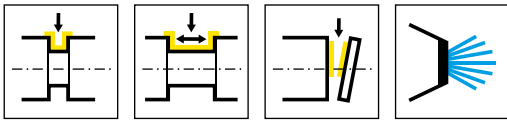

R = rechts wie gezeichnet
R = right hand version shown

L = links spiegelbildlich
L = left hand version

Bestellnummer Part number	h	b	l ₁	l ₃	h ₁	f ₁	f	t _{max}	D _{max}	HWS
RH224.1212.20.61.IK	12	12	100	23	12	0,7	f ₁ +w/2	10,5	21	224018
RH224.1212.20.62.IK	12	12	100	23	12	0,9	f ₁ +w/2	10,5	21	224028
RH224.1212.20.63.IK	12	12	100	23	12	1,1	f ₁ +w/2	10,5	21	224038
LH224.1212.20.61.IK	12	12	100	23	12	0,7	f ₁ +w/2	10,5	21	224018
LH224.1212.20.63.IK	12	12	100	23	12	1,1	f ₁ +w/2	10,5	21	224038

w siehe WSP
w see indexable inserts



Ersatzteile
Spare Parts

Klemmhalter Toolholder	Spannschraube Clamping Screw	Kühlmittelanschluss Coolant supply	TORX PLUS®-Schlüssel TORX PLUS® Wrench
R/LH224...	4.12T15EP	004.00.22	T15PL

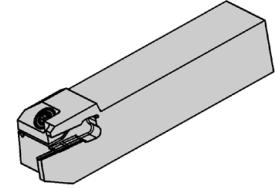
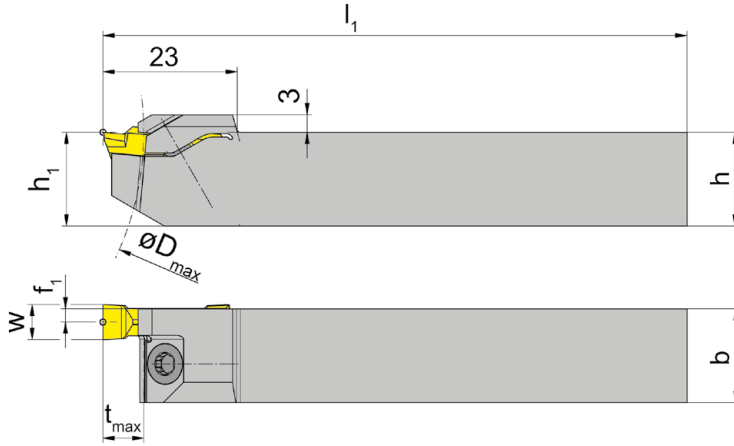
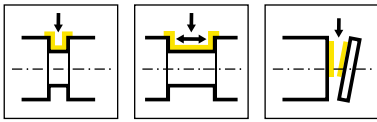

L = links wie gezeichnet
L = left hand version shown

R = rechts spiegelbildlich
R = right hand version

Bestellnummer Part number	h	b	l ₁	h ₁	f ₁	t _{max}	D _{max}	HWS
RH224.2020.65	20	20	100	20	1,85	7	100	224058
RH224.1616.65	16	16	100	16	1,85	7	100	224058
RH224.2020.66	20	20	100	20	2,25	7	100	224068
RH224.1616.66	16	20	125	20	2,25	7	100	224068
LH224.2020.65	20	20	100	20	1,85	7	100	224058
LH224.1616.65	16	16	100	16	1,85	7	100	224058
LH224.2020.66	20	20	100	20	2,25	7	100	224068
LH224.1616.66	16	16	100	16	2,25	7	100	224068

w siehe WSP
w see indexable inserts

Ersatzteile
Spare Parts

Klemmhalter Toolholder	Spannschraube Clamping Screw	TORX PLUS®-Schlüssel TORX PLUS® Wrench
R/LH224...	5.13T20EP	T20PQ

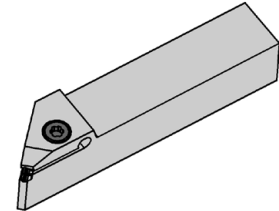
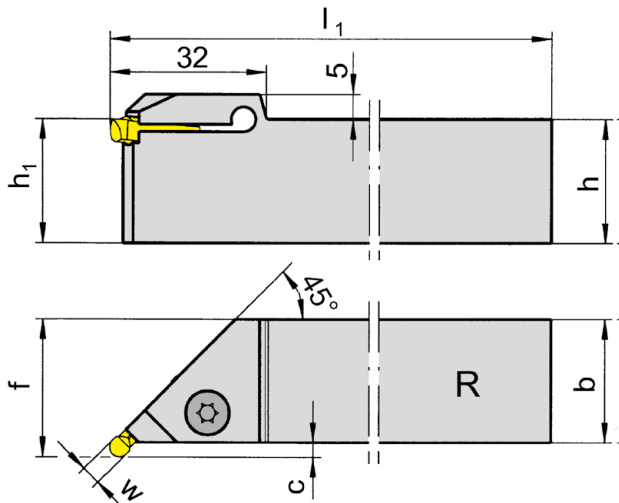
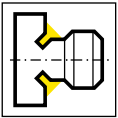

R = rechts wie gezeichnet
R = right hand version shown

L = links spiegelbildlich
L = left hand version

Bestellnummer Part number	h	b	l ₁	h ₁	f	C	Schneidbreite Width of groove	HWS
RH224.4520.02	20	20	125	20	23	2,5	2,0-2,8	224028
RH224.4520.04	20	20	125	20	23	2,5	2,8-4,4	224048
RH224.4520.06	20	20	125	20	23,5	3	4,4-6,1	224068
LH224.4520.02	20	20	125	20	23	2,5	2,0-2,8	224028
LH224.4520.04	20	20	125	20	23	2,5	2,8-4,4	224048
LH224.4520.06	20	20	125	20	23,5	3	4,4-6,1	224068

w und Dmin siehe WSP
w and Dmin see indexable inserts



Ersatzteile
Spare Parts

Klemmhalter Toolholder	Spannschraube Clamping Screw	TORX PLUS®-Schlüssel TORX PLUS® Wrench
R/LH224...	6.23T25P	T25PQ

Wendeschnidplatte

Indexable insert

S224

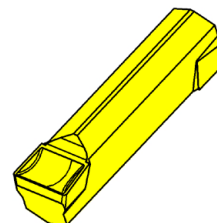
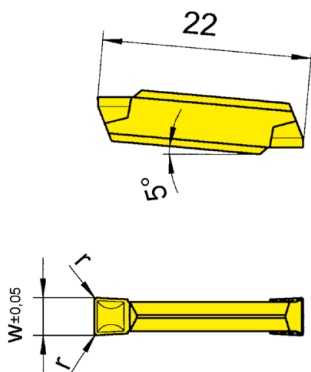
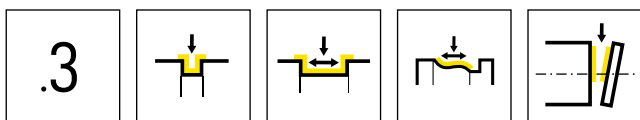

HM-Sorten
Carbide grades

▲ ab Lager
on stock

△ 4 Wochen
4 weeks

Bestellnummer Part number	w	r	HIS	HM-Sorten Carbide grades										
				AL96	AS62	AS66	H54	IG66	TC92	TF45	TI22	TI25	TN32	TN35
S224.0300.32	3	0,2	224038	▲	▲	▲	△	▲	▲	▲	△	▲	▲	▲
S224.0300.34	3	0,4	224038	▲	▲	▲	△	▲	▲	▲	△	▲	▲	▲
S224.0400.32	4	0,2	224048	△	▲	▲	△	▲	△	▲	▲	▲	▲	▲
S224.0400.34	4	0,4	224048	▲	▲	▲	△	▲	▲	▲	△	▲	▲	▲
S224.0500.34	5	0,4	224058	▲	▲	▲	△	▲	▲	▲	△	▲	▲	▲
S224.0500.38	5	0,8	224058	△	▲	▲	△	▲	▲	▲	▲	▲	△	△
S224.0600.34	6	0,4	224068	△	▲	▲	△	▲	△	▲	▲	▲	▲	▲
S224.0600.38	6	0,8	224068	△	▲	▲	△	▲	△	▲	▲	△	▲	▲
P				●	●	●	●	●	●	●	●	●	●	●
M				-	-	○	●	●	-	●	-	●	-	●
K				●	-	●	-	-	-	●	-	●	-	●
N				●	-	●	-	-	-	●	-	●	-	●
S				-	-	○	-	○	-	●	-	●	-	●
H				-	-	-	-	-	-	-	-	-	-	-

G

Wendeschnidplatte

Indexable insert

S224

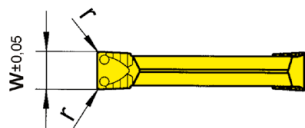
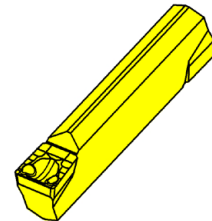
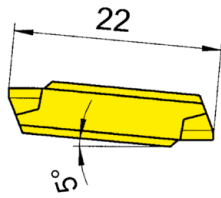
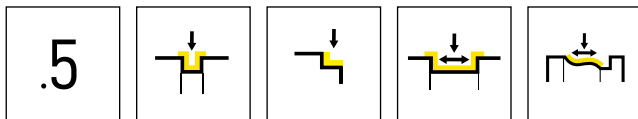

HM-Sorten
Carbide grades

▲ ab Lager
on stock

△ 4 Wochen
4 weeks

Bestellnummer Part number	w	r	HIS	AL96	AS62	AS66	EG56	H54	IG66	TC92	TF45	TI25	TN32	TN35
S224.0200.52	2	0,2	224018		▲	▲	▲		▲					
S224.0250.52	2,5	0,2	224028		▲	▲	▲		▲					
S224.0300.52	3	0,2	224038	△	▲	▲	▲	△	▲	▲	▲	▲	▲	▲
S224.0300.54	3	0,4	224038	▲	▲	▲	▲	△	▲	▲	▲	▲	▲	▲
S224.0400.52	4	0,2	224048	▲	▲	▲	▲	△	▲	△	▲	▲	▲	▲
S224.0400.54	4	0,4	224048	▲	▲	▲	▲	△	▲	▲	▲	▲	▲	▲
S224.0500.54	5	0,4	224058	△	▲	▲	▲	△	▲	▲	▲	▲	▲	▲
S224.0500.58	5	0,8	224058	△	▲	▲	△	△	▲		△	▲	△	△
S224.0600.54	6	0,4	224068	△	▲	▲	▲	△	▲		▲	▲	△	▲
S224.0600.58	6	0,8	224068	△	▲	▲	△	△	▲	△	△	△	△	△
P				●	●	●	●	●	●	●	●	●	●	●
M				-	-	○	○	●	●	-	●	●	-	●
K				●	-	●	○	-	-	-	●	●	-	●
N				●	-	●	-	-	-	-	●	●	-	●
S				-	-	○	-	-	○	-	●	●	-	●
H				-	-	-	-	-	-	-	-	-	-	-



Wendeschnidplatte

Indexable insert

S224

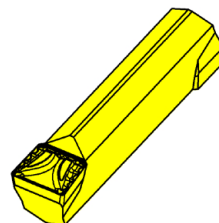
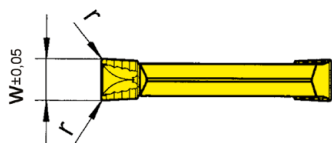
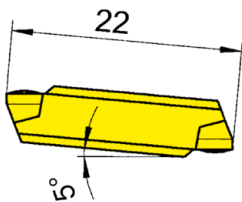
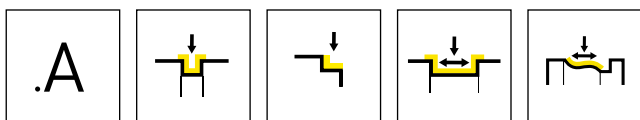

HM-Sorten
Carbide grades

▲ ab Lager
on stock

△ 4 Wochen
4 weeks

Bestellnummer Part number	w	r	HIS	AL96	AS62	AS65	TC92	TF45	TI22	TI25	TN32	TN35
				▲	▲	▲	▲	▲	▲	▲	▲	▲
S224.0300.A2	3	0,2	224038	▲	▲			▲	△	▲	△	▲
S224.0300.A4	3	0,4	224038	△	▲		△	▲	△	▲	▲	▲
S224.0400.A2	4	0,2	224048	△	▲		△	△	△	▲	△	▲
S224.0400.A4	4	0,4	224048		▲	▲	△	▲	△	▲	△	▲
S224.0500.A4	5	0,4	224058	△	▲			▲		▲	▲	▲
S224.0500.A8	5	0,8	224058	△	▲		△	△		△	▲	△
S224.0600.A4	6	0,4	224068	△	▲		△	△		▲		▲
S224.0600.A8	6	0,8	224068	△	▲		△	△		△	△	▲
P				●	●	●	●	●	●	●	●	●
M				-	-	○	-	●	-	●	-	●
K				●	-	○	-	●	-	●	-	●
N				●	-	-	-	●	-	●	-	●
S				-	-	-	-	●	-	●	-	●
H				-	-	-	-	-	-	-	-	-

G

Wendeschnidplatte

Indexable insert

S224

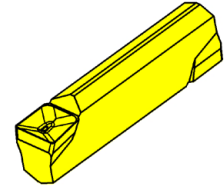
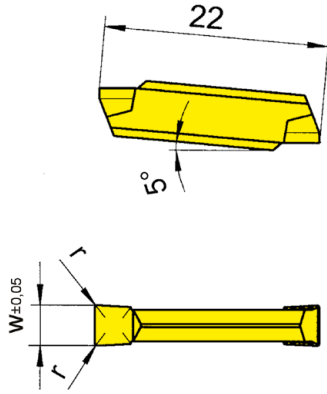
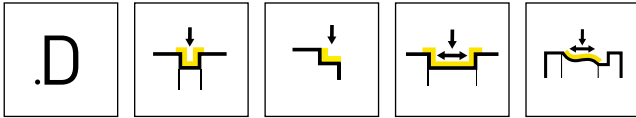

HM-Sorten
Carbide grades

▲ ab Lager
on stock

△ 4 Wochen
4 weeks

Bestellnummer Part number	w	r	HIS	HM-Sorten Carbide grades							
				H54	IG66	TF45	TF46	TI22	TI25	TN32	TN35
S224.0200.D2	2	0,2	224018	▲	▲	▲	▲		▲	▲	▲
S224.0200.D2.G	2	0,2	224018		▲		▲	▲	▲	▲	▲
S224.0250.D2	2,5	0,2	224028	△	▲	▲	▲	▲	▲	▲	▲
S224.0250.D2.G	2,5	0,2	224028		▲		▲	▲	▲	▲	▲
S224.0300.D2	3	0,2	224038	▲	▲	▲	▲		▲	▲	▲
S224.0300.D2.G	3	0,2	224038		▲	▲	▲	▲	▲	▲	▲
S224.0400.D2	4	0,2	224048	△	▲	▲	▲		▲	△	▲
S224.0400.D2.G	4	0,2	224048		▲		▲	▲	▲	▲	▲
P				●	●	●	●	●	●	●	●
M				●	●	●	○	-	●	-	●
K				-	-	●	●	-	●	-	●
N				-	-	●	●	-	●	-	●
S				-	○	●	○	-	●	-	●
H				-	-	-	-	-	-	-	-



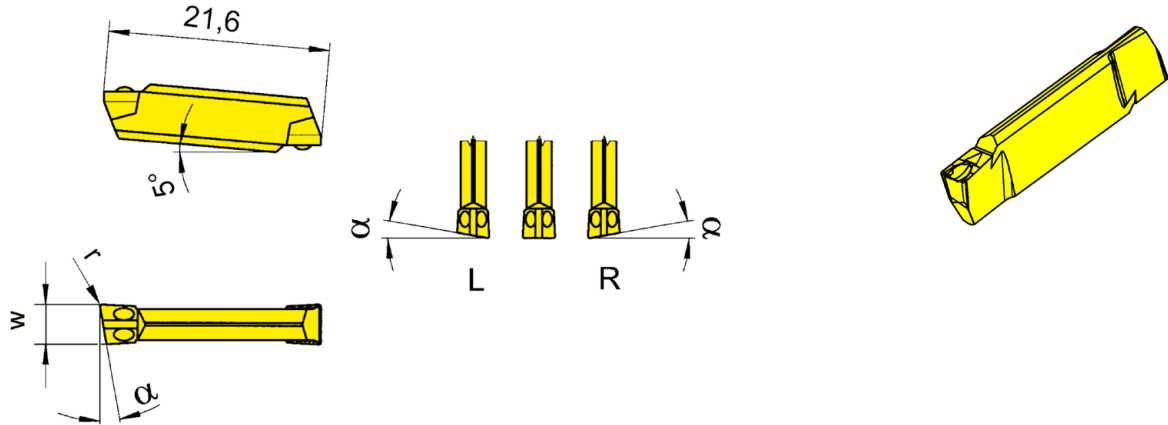
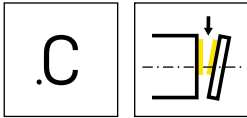

R = rechts wie gezeichnet
R = right hand version shown

L = links spiegelbildlich
L = left hand version

▲ ab Lager
on stock

HM-Sorten
Carbide grades
Δ 4 Wochen
4 weeks

Bestellnummer Part number	w	r	α	HIS	TC92	TF45	TI25	TN35
RS224.0520.C1	2	0,15	5°	224018	Δ	▲		▲
RS224.0820.C1	2	0,15	8°	224018	Δ	▲		Δ
RS224.1520.C1	2	0,15	15°	224018	Δ	▲		▲
RS224.0525.C1	2,5	0,15	5°	224028	Δ	▲		Δ
RS224.0825.C1	2,5	0,15	8°	224028	Δ	▲		Δ
RS224.0530.C1	3	0,15	5°	224038	Δ	▲		▲
RS224.0830.C1	3	0,15	8°	224038	Δ	▲		▲
LS224.0520.C1	2	0,15	5°	224018	Δ	▲		▲
LS224.0820.C1	2	0,15	8°	224018	Δ	▲		Δ
LS224.1520.C1	2	0,15	15°	224018	Δ	▲		▲
LS224.0525.C1	2,5	0,15	5°	224028	Δ	▲		Δ
LS224.0825.C1	2,5	0,15	8°	224028	Δ	▲		Δ
LS224.0530.C1	3	0,15	5°	224038	Δ	▲		▲
LS224.0830.C1	3	0,15	8°	224038	Δ	▲		▲
S224.0020.C1	2	0,15	0°	224018	▲	▲	▲	▲
S224.0025.C1	2,5	0,15	0°	224028	Δ	▲	▲	▲
S224.0030.C1	3	0,15	0°	224038	Δ	▲	▲	▲

P	●	●	●	●
M	-	●	●	●
K	-	●	●	●
N	-	●	●	●
S	-	●	●	●
H	-	-	-	-

Wendeschnidplatte

Indexable insert

S224

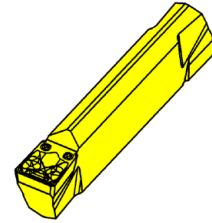
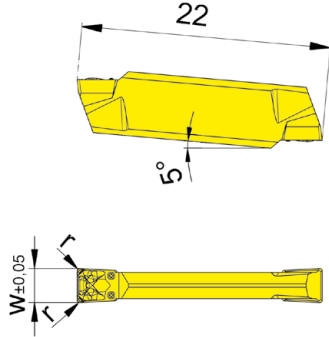
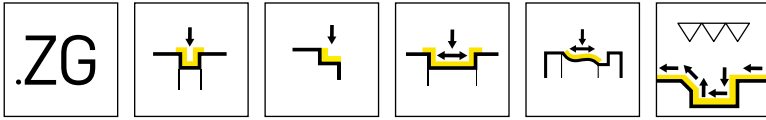

HM-Sorten
Carbide grades

▲ ab Lager
on stock

△ 4 Wochen
4 weeks

Bestellnummer Part number	w	r	HIS	ALXT	IG6T
S224.0300.ZG2	3	0,2	224038	▲	▲
S224.0400.ZG4	4	0,4	224048	▲	▲
				P ● ●	● ●
				M ○ ●	● ●
				K - -	- -
				N - -	- -
				S - ○	○
				H - -	- -



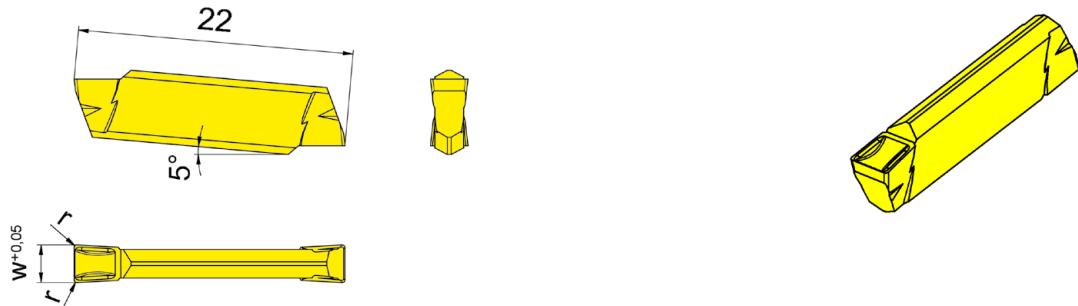
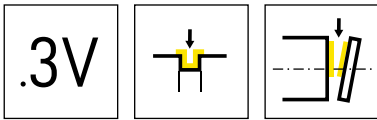

HM-Sorten
Carbide grades

▲ ab Lager
on stock

△ 4 Wochen
4 weeks

Bestellnummer Part number	w	r	HIS	AS45	HP65	IG35
S224.0200.3V2	2	0,2	224018	▲	▲	▲
S224.0250.3V2	2,5	0,2	224028	▲	▲	▲
S224.0300.3V2	3	0,2	224038	▲	▲	▲
S224.0400.3V3	4	0,3	224048	▲	▲	▲
P	●	●	-			
M	●	●	●			
K	●	●	-			
N	o	o	-			
S	●	●	●			
H	-	-	-			

G

Wendeschneidplatte

Indexable insert

S224

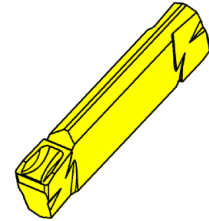
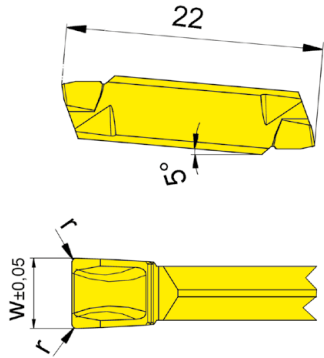
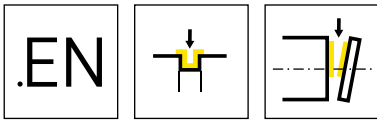

▲ ab Lager
 on stock

▲ 4 Wochen
 4 weeks

Bestellnummer Part number	w	r	HIS	AS62	AS65
S224.0200.EN2	2	0,2	224018	▲	
S224.0250.EN2	2,5	0,2	224028	▲	
S224.0300.EN2	3	0,2	224038	▲	▲
				P ● ●	
				M - ○	
				K - ○	
				N - -	
				S - -	
				H - -	



Wendeschnidplatte

Indexable insert

S224

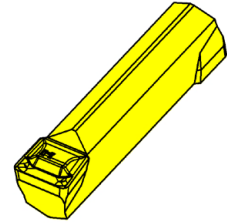
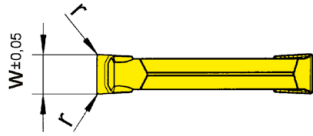
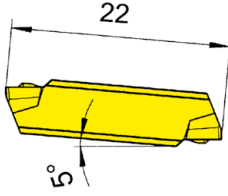
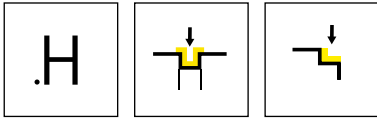

HM-Sorten
Carbide grades

▲ ab Lager
on stock

△ 4 Wochen
4 weeks

Bestellnummer Part number	w	r	HIS	AL96	TF42
S224.0300.H4	3	0,4	224038	▲	▲
S224.0400.H4	4	0,4	224048	△	▲
S224.0500.H6	5	0,6	224058	▲	▲
S224.0500.H8	5	0,8	224058	△	
S224.0600.H6	6	0,6	224068		△
S224.0600.H8	6	0,8	224068		△
				P ● ●	
				M - -	
				K ● -	
				N ● -	
				S - -	
				H - -	

G

Wendeschnidplatte

Indexable insert

S224

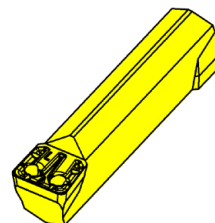
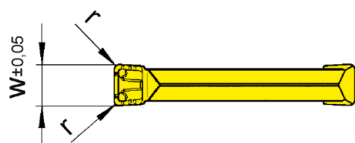
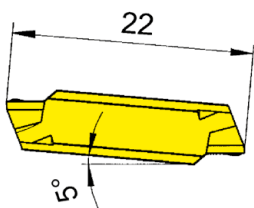
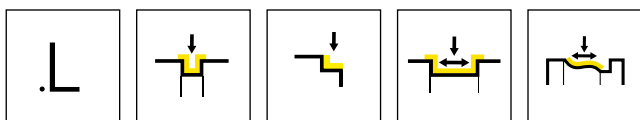

HM-Sorten
Carbide grades

▲ ab Lager
on stock

△ 4 Wochen
4 weeks

Bestellnummer Part number	w	r	HIS	AL96	AS62	AS65	AS66	ASG6	IG66	TF42	TI22
S224.0300.L4	3	0,4	224038		▲	▲		▲	▲		
S224.0400.L4	4	0,4	224048	▲	▲		▲	▲	▲	▲	▲
S224.0500.L4	5	0,4	224058	▲	▲		▲	△	▲	▲	▲
S224.0500.L6	5	0,6	224058	△	▲		▲	△	▲	▲	▲
S224.0600.L4	6	0,4	224068	△	▲				▲	▲	▲
S224.0600.L6	6	0,6	224068	▲	▲			△	▲	△	▲
P	●	●	●	●	●	●	●	●	●	●	●
M	-	-	○	○	○	○	○	○	○	-	-
K	●	-	○	○	○	○	○	○	-	-	-
N	●	-	-	●	-	-	-	-	-	-	-
S	-	-	-	○	-	○	-	○	-	-	-
H	-	-	-	-	-	-	-	-	-	-	-



Wendeschneidplatte

Indexable insert

S224

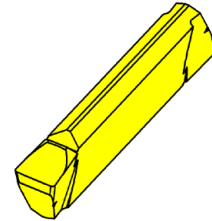
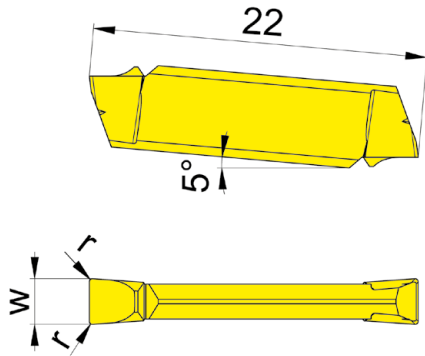
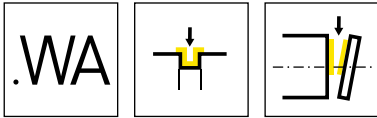

HM-Sorten
Carbide grades

▲ ab Lager
on stock

△ 4 Wochen
4 weeks

Bestellnummer Part number	w	r	HIS	K10	DD26
S224.0200.WA2	2	0,2	224018	▲	▲
S224.0300.WA2	3	0,2	224038	▲	▲
				P ●	-
				M ○	-
				K ●	-
				N ●	●
				S ○	○
				H -	-

G

Wendeschneidplatte

Indexable insert

S224

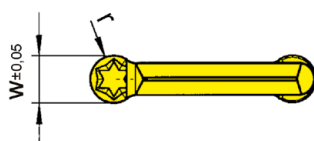
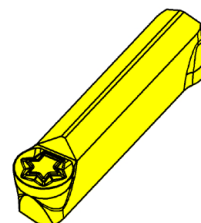
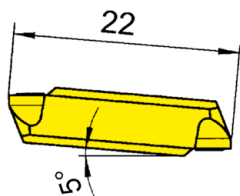
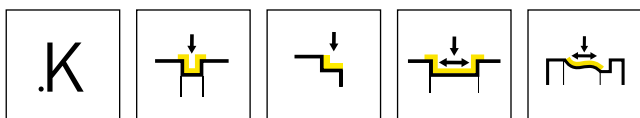

HM-Sorten
Carbide grades

▲ ab Lager
on stock

△ 4 Wochen
4 weeks

Bestellnummer Part number	w	r	HIS	HM-Sorten Carbide grades									
				P20	AL96	AS62	AS66	IG66	TC92	TF42	TN32	TN35	
S224.0010.K2	2	1	224018			▲	▲	▲					
S224.0015.K3	3	1,5	224038	△	▲	▲	▲	▲	▲	▲	▲	▲	
S224.0020.K4	4	2	224048	△	▲	▲	▲	▲	▲	▲	▲	▲	
S224.0025.K5	5	2,5	224058	△	▲	▲	▲	▲	△	▲	▲	▲	
S224.0030.K6	6	3	224068	△		▲	▲	▲					△
P	●	●	●	●	●	●	●	●	●	●	●	●	●
M	-	-	-	O	●	-	-	-	-	-	-	-	●
K	-	●	-	●	-	-	-	-	-	-	-	-	●
N	-	●	-	●	-	-	-	-	-	-	-	-	●
S	-	-	-	O	O	-	-	-	-	-	-	-	●
H	-	-	-	-	-	-	-	-	-	-	-	-	-



Wendeschnidplatte

Indexable insert

S224

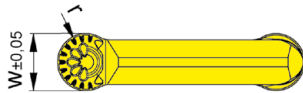
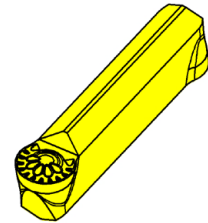
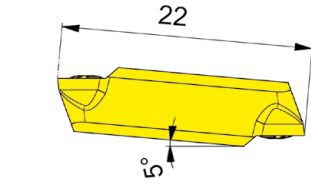
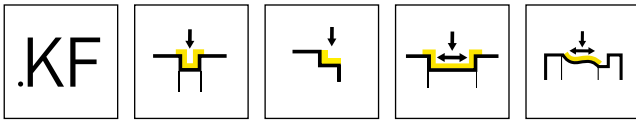

HM-Sorten
Carbide grades

▲ ab Lager
on stock

△ 4 Wochen
4 weeks

Bestellnummer Part number	w	r	HIS	AS62	AS66	EG55	IG66	TA42
S224.0010.KF2	2	1	224018		▲	▲		
S224.0015.KF3	3	1,5	224038		▲		▲	
S224.0020.KF4	4	2	224048		▲		▲	△
S224.0025.KF5	5	2,5	224058	△	▲		▲	
S224.0030.KF6	6	3	224068		▲		▲	
				P	●	●	●	●
				M	-	○	○	●
				K	-	●	○	-
				N	-	●	-	-
				S	-	○	-	○
				H	-	-	-	-

G

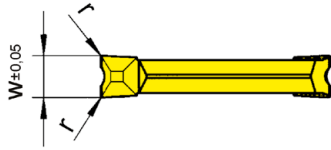
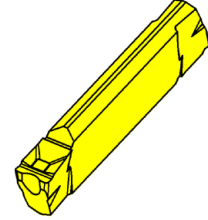
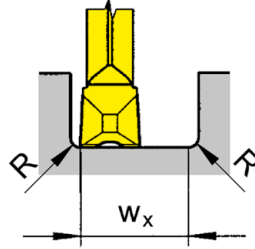
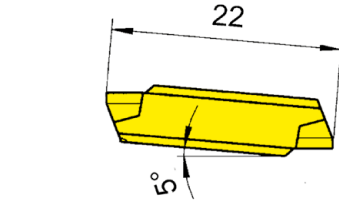
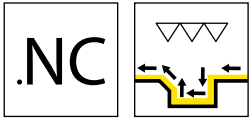

HM-Sorten
Carbide grades

▲ ab Lager
on stock

△ 4 Wochen
4 weeks

Bestellnummer Part number	w	r	w _x	HIS	TF46	TI22	TI25	TI26
S224.NC25.D2	2,5	0,2	3,6	224028	△	▲	▲	▲
S224.NC30.D2	3	0,2	4,5	224038	△	▲	▲	▲
					P	●	●	●
					M	○	-	○
					K	●	-	●
					N	●	-	●
					S	○	-	○
					H	-	-	-

w_x = Nutbreite - R(rechts) - R(links)
w_x = width of groove - R(right) - R(left)



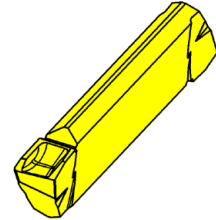
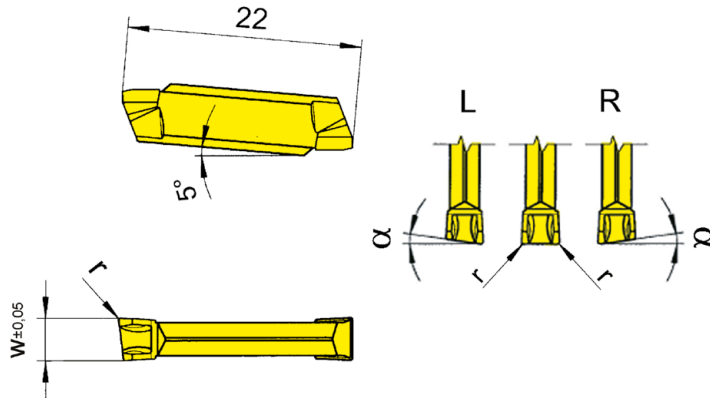
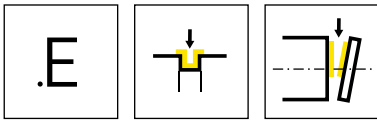

R = rechts wie gezeichnet
R = right hand version shown

L = links spiegelbildlich
L = left hand version

▲ ab Lager
on stock

HM-Sorten
Carbide grades
Δ 4 Wochen
4 weeks

Bestellnummer Part number	w	r	α	HIS	AL96	AS62	TA43	TC92	TC93	TF43	TF45	TI22	TI25	TN32	TN35
RS224.0520.E2	2	0,2	5°	224018		▲		Δ	Δ	Δ					
RS224.0525.E2	2,5	0,2	5°	224028		▲		Δ	Δ	Δ	Δ				
RS224.0530.E2	3	0,2	5°	224038		▲		Δ	Δ	Δ	▲				
LS224.0520.E2	2	0,2	5°	224018		Δ		Δ	Δ	Δ	Δ				
LS224.0525.E2	2,5	0,2	5°	224028		Δ		Δ	Δ	Δ	Δ				
LS224.0530.E2	3	0,2	5°	224038		▲		Δ	Δ	Δ	▲				
S224.0200.E2	2	0,2	0°	224018		▲		Δ		▲	▲				
S224.0250.E2	2,5	0,2	0°	224028		▲		Δ	Δ	▲	▲				
S224.0300.E2	3	0,2	0°	224038	Δ	▲	Δ	Δ	Δ	▲	▲	▲	▲	Δ	Δ
S224.0300.E4	3	0,4	-	224038	Δ	▲		Δ	Δ	Δ	▲		Δ	Δ	Δ
S224.0400.E2	4	0,2	0°	224048	Δ	▲		Δ	Δ	Δ	▲		Δ	Δ	Δ
S224.0400.E4	4	0,4	-	224048	Δ	▲		Δ	Δ	Δ	▲		Δ	Δ	Δ
P	●	●	●	●	●	●	●	●	●	●	●	●	●	●	●
M	-	-	-	-	-	-	-	-	-	-	●	-	●	-	●
K	●	-	-	-	-	-	-	-	-	-	●	-	●	-	●
N	●	-	-	-	-	-	-	-	-	-	●	-	●	-	●
S	-	-	-	-	-	-	-	-	-	-	●	-	●	-	●
H	-	-	-	-	-	-	-	-	-	-	-	-	-	-	-

G

Wendeschnidplatte

Indexable insert

S224

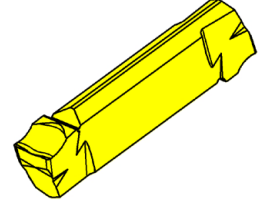
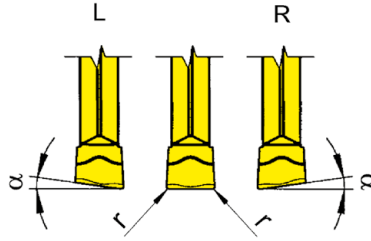
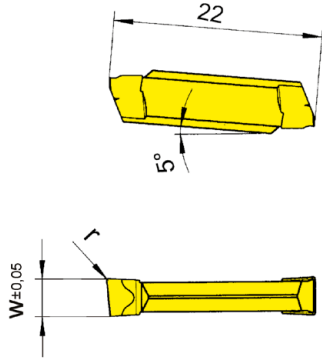
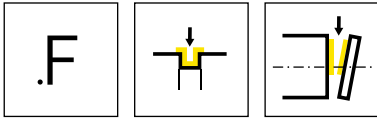

HM-Sorten
Carbide grades

▲ ab Lager
on stock

△ 4 Wochen
4 weeks

Bestellnummer Part number	w	r	α	HIS	AL96	TA43	TF42	TF43	TF45	TF46	TI22	TI25	TN32
RS224.0520.F2	2	0,2	5°	224018					▲	▲			
RS224.0525.F2	2,5	0,2	5°	224028				▲	▲				
RS224.0530.F2	3	0,2	5°	224038				▲	▲		△		
LS224.0520.F2	2	0,2	5°	224018					▲	△			
LS224.0525.F2	2,5	0,2	5°	224028					▲				
LS224.0530.F2	3	0,2	5°	224038				△	▲				
S224.0200.F2	2	0,2	0°	224018	△		△	▲	▲	▲	▲	▲	△
S224.0250.F2	2,5	0,2	0°	224028	△		△	△	▲	△	△	△	△
S224.0300.F2	3	0,2	0°	224038	△	△		▲	▲		△	▲	△
S224.0400.F2	4	0,2	0°	224048	△		△		▲		▲	△	△
P					●	●	●	●	●	●	●	●	●
M					-	-	-	-	●	○	-	●	-
K					●	-	-	-	●	●	-	●	-
N					●	-	-	-	●	●	-	●	-
S					-	-	-	-	●	○	-	●	-
H					-	-	-	-	-	-	-	-	-



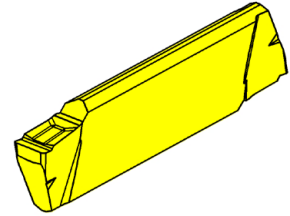
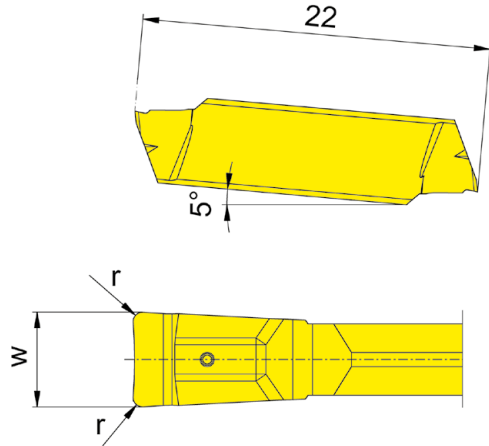
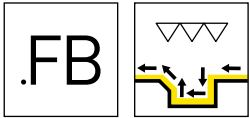

HM-Sorten
Carbide grades

▲ ab Lager
on stock

Δ 4 Wochen
4 weeks

Bestellnummer Part number	w	r	HIS	IG6T	H20
S224.FB20.02	2	0,2	224018	Δ	▲
S224.FB30.02	3	0,2	224038	Δ	▲
				P ● ●	
				M ● ○	
				K - -	
				N - -	
				S ○ -	
				H - -	

Berechnung der kleinstmöglichen Nutbreite w_x
Calculation of the smallest possible width of groove w_x

Beispiel S224.FB20.02
Example

$$w_x = 2 \times \text{Schneidbreite/Width of insert } w - 2 \times \text{Eckenradius Schneidplatte/Corner radius insert } r$$

$$w_x = 2 \times 2 \text{ mm} - 2 \times 0,2 \text{ mm}$$

$$w_x = 3,6 \text{ mm}$$

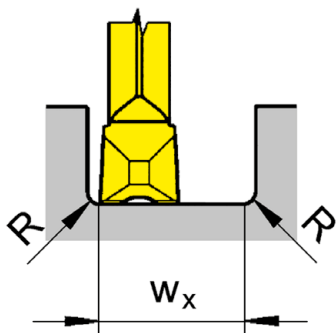

Bearbeitungsablauf
Processing flow

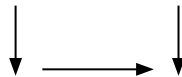

Wendeschneidplatte

Indexable insert

S224

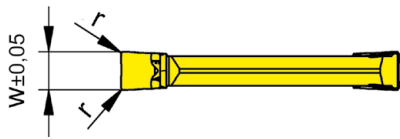
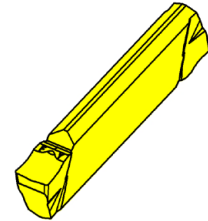
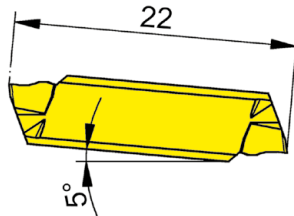
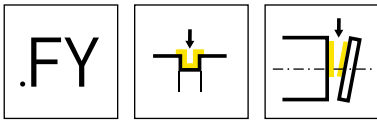

HM-Sorten
Carbide grades

▲ ab Lager
on stock

△ 4 Wochen
4 weeks

Bestellnummer Part number	w	r	HIS	HM-Sorten Carbide grades			
				HP65	IG35	PH35	TI25
S224.0200.FY2	2	0,2	224018	▲	▲	△	▲
S224.0250.FY2	2,5	0,2	224028	▲	▲	△	▲
S224.0300.FY2	3	0,2	224038	▲	▲	△	▲
				P	●	-	●
				M	●	●	●
				K	●	-	●
				N	○	-	●
				S	●	●	●
				H	-	-	-



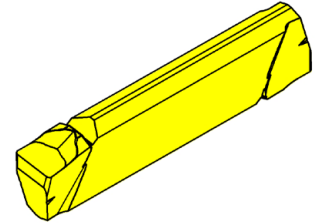
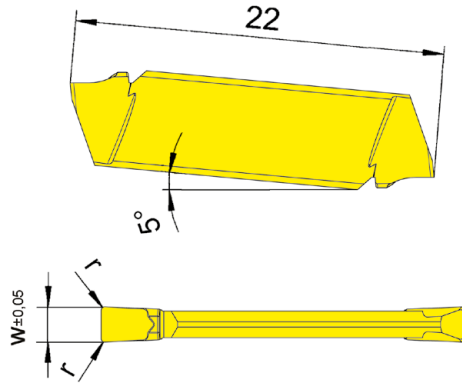
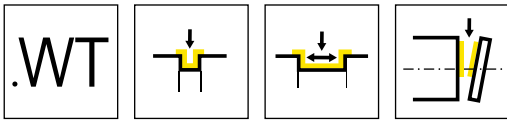

HM-Sorten
Carbide grades

▲ ab Lager
on stock

△ 4 Wochen
4 weeks

Bestellnummer Part number	w	r	HIS	IG35
S224.0200.WT2	2	0,2	224018	▲
S224.0250.WT2	2,5	0,2	224028	▲
S224.0300.WT2	3	0,2	224038	▲
				P -
				M ●
				K -
				N -
				S ●
				H -

G

Wendeschnidplatte

Indexable insert

S224

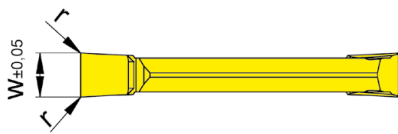
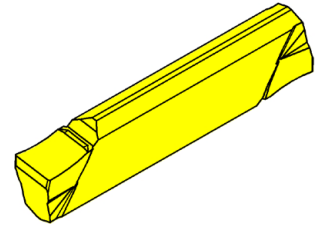
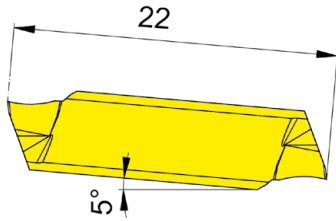
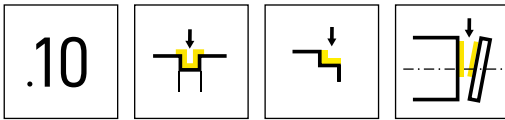

HM-Sorten
Carbide grades

▲ ab Lager
on stock

△ 4 Wochen
4 weeks

Bestellnummer Part number	w	r	HIS	EG35	IG66
S224.0200.10	2	0,05	224028	▲	△
S224.0250.10	2,5	0,1	224028	▲	△
S224.0300.10	3	0,1	224038	▲	△
				P ● ●	
				M ● ●	
				K ○ -	
				N - -	
				S - ○	
				H - -	



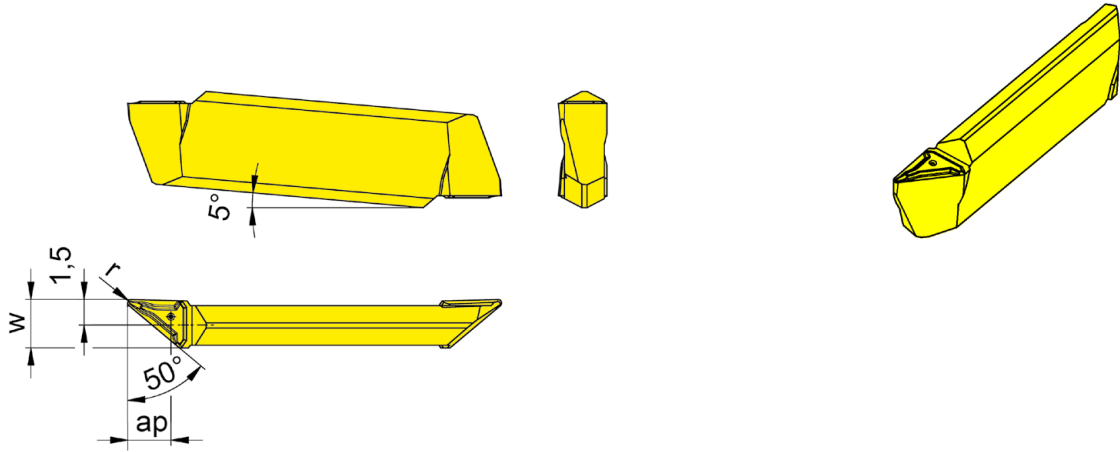
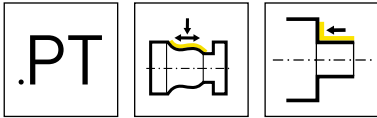

R = rechts wie gezeichnet
R = right hand version shown

L = links spiegelbildlich
L = left hand version

▲ ab Lager
on stock

HM-Sorten
Carbide grades
Δ 4 Wochen
4 weeks

Bestellnummer Part number	w	r	a _p	HIS	EG55	IG35	
RS224.5028.PT2	2,8	0,2	2,5	224038	▲	▲	
LS224.5028.PT2	2,8	0,2	2,5	224038	▲	▲	
für Klemmhalter H224.1...6.03.IK for Toolholder H224.1...6.03.IK					P	●	-
					M	○	●
					K	○	-
					N	-	-
					S	-	●
					H	-	-

G

Wendeschneidplatte

Indexable insert

S224

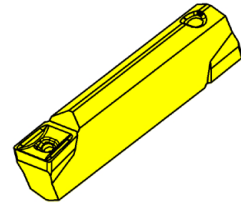
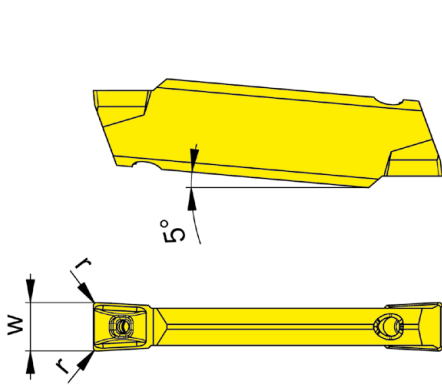
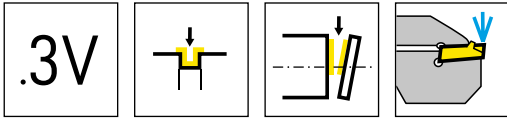

HM-Sorten
Carbide grades

▲ ab Lager
on stock

Δ 4 Wochen
4 weeks

Bestellnummer Part number	w	r	HIS	HM-Sorten Carbide grades	
				HP65	IG35
S224.0300.3V2.IK	3	0,2	224039	▲	▲
				P ●	-
				M ●	●
				K ●	-
				N ○	-
				S ●	●
				H -	-





G

262

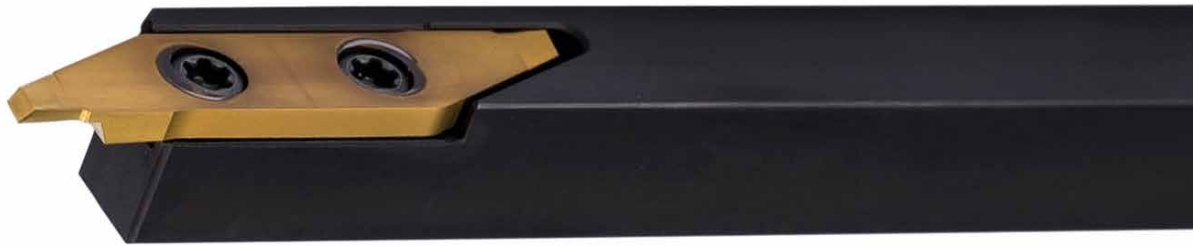

**Klemmhalter und
Schneidplatten**

**Toolholder and
Inserts**

H

Einstecken (außen)

Grooving (external)



Klemmhalter
Toolholder
H262

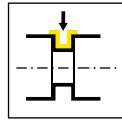

Seite/Page
417

Wendeschneidplatte
Indexable insert
S262

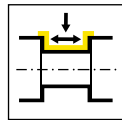

Seite/Page
418-419, 421

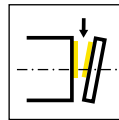

Seite/Page
420

Geometrie
Geometry

Werkstoff
Material

Vorschubbereich f [mm/U]
Feed rate f [mm/rev]

S262

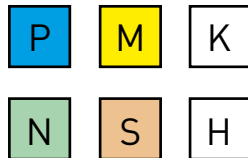

↓ 0,01-0,10
↔ 0,002-0,02

H

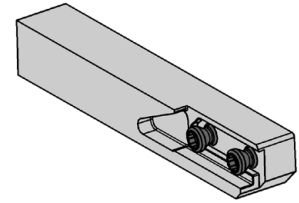
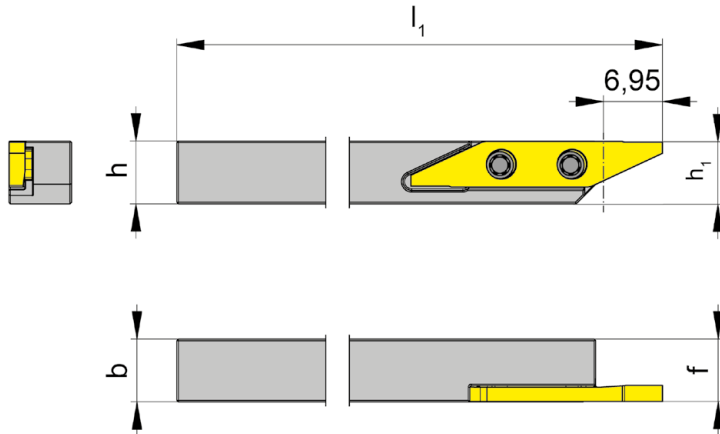
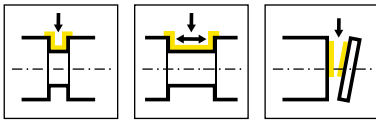

L = links wie gezeichnet
L = left hand version shown

Bestellnummer Part number	h	b	l ₁	h ₁	f	t _{max}	HWS
LH262.0606.04	6	6	100	5,83	5,95	7,5	26204L
LH262.0707.04	7	7	100	6,83	6,95	7,5	26204L
LH262.0808.04	8	8	100	7,83	7,95	7,5	26204L
LH262.0808.2.04	8	8	150	7,83	7,95	7,5	26204L
LH262.1010.04	10	10	100	9,83	9,95	7,5	26204L

Ersatzteile
Spare Parts

Klemmhalter Toolholder	Spannschraube Clamping Screw	TORX PLUS®-Schlüssel TORX PLUS® Wrench
LH262...	030.2557.T8P	T8PL

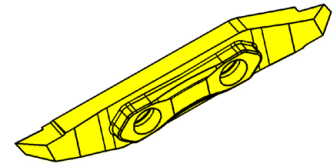
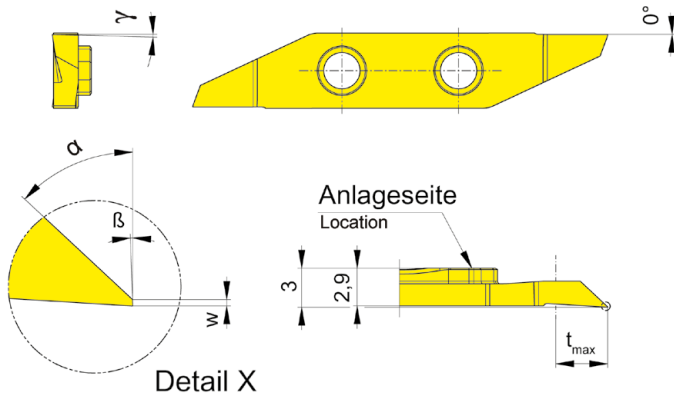
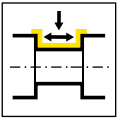

L = links wie gezeichnet
L = left hand version shown

HM-Sorten
Carbide grades
▲ ab Lager
on stock
Δ 4 Wochen
4 weeks

Bestellnummer Part number	w	t _{max}	γ	α	β	HIS	EG35
LS262.0247.04	0,025	1,8	1,5°	47°	2°	26204L	▲
							P ●
							M ●
							K ○
							N -
							S -
							H -

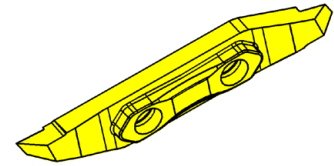
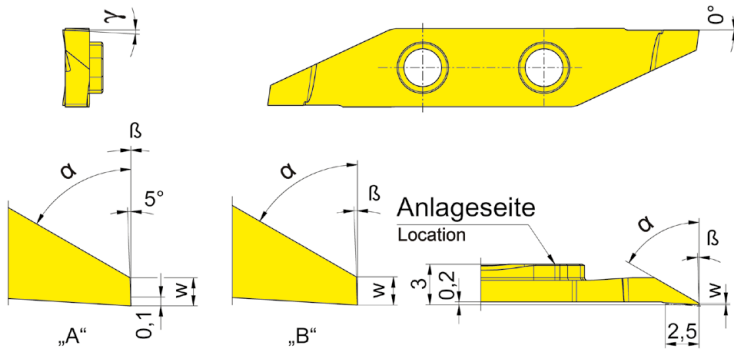
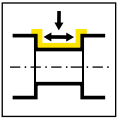

L = links wie gezeichnet
L = left hand version shown

HM-Sorten
Carbide grades
▲ ab Lager
on stock
Δ 4 Wochen
4 weeks

Bestellnummer Part number	w	t _{max}	γ	α	Form	β	HIS	EG35
LS262.0147.04	0,03	1,8	0°	47°	A	0°	26204L	▲
LS262.0160.03	0,105	3	3°	60°	B	2°	26204L	▲
								P ●
								M ●
								K ○
								N -
								S -
								H -



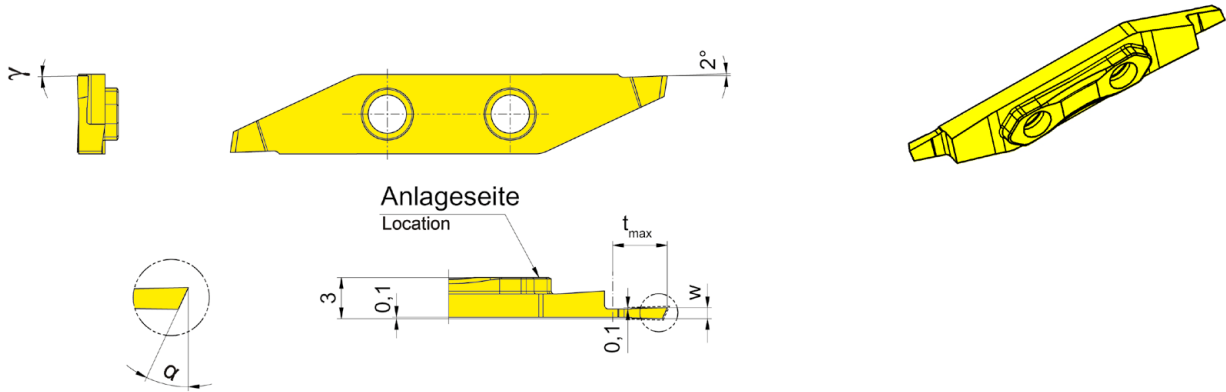
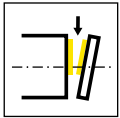

L = links wie gezeichnet
L = left hand version shown

HM-Sorten
Carbide grades
▲ ab Lager
on stock
Δ 4 Wochen
4 weeks

Bestellnummer Part number	w	t _{max}	γ	α	HIS	EG35
LS262.2007.02	0,7	2	0°	20°	26204L	▲
LS262.2508.03	0,8	3	0°	25°	26204L	▲
LS262.2509.04	0,9	4	0°	25°	26204L	▲
LS262.2510.05	1	5	0°	25°	26204L	▲
						P ●
						M ●
						K ○
						N -
						S -
						H -

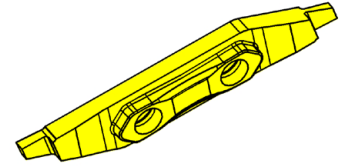
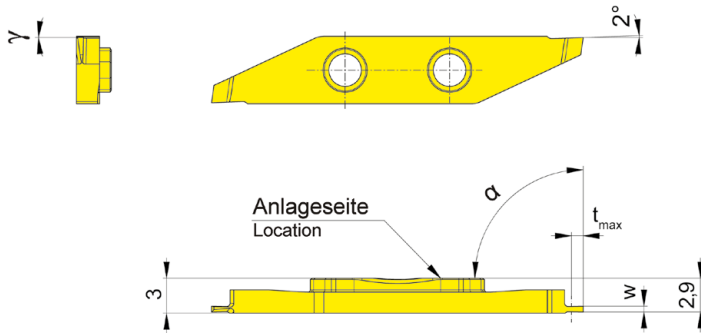
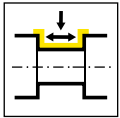

L = links wie gezeichnet
L = left hand version shown

▲ ab Lager
on stock

HM-Sorten
Carbide grades
Δ 4 Wochen
4 weeks

Bestellnummer Part number	w	t _{max}	γ	α	HIS	EG35
LS262.0005.01	0,5	1	0°	90°	26204L	▲
LS262.0012.02	1,2	2	0°	90°	26204L	▲
LS262.0015.03	1,5	3	0°	90°	26204L	▲
						P ●
						M ●
						K ○
						N -
						S -
						H -





H

264



**Klemmhalter und
Schneidplatten**

**Toolholder and
Inserts**



Geometrien und
Vorschübe
Geometries and feed rates

Seite/Page
425

Klemmhalter
Toolholder
H264

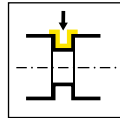

Seite/Page
426-430

Wendeschneidplatte
Indexable insert
264

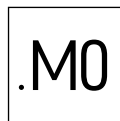

Seite/Page
431-432

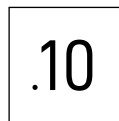

Seite/Page
433-434

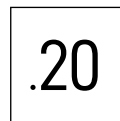

Seite/Page
435

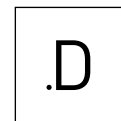

Seite/Page
436

Geometrien und Vorschübe

Geometries and feed rates



Geometrie Geometry	Werkstoff Material	Vorschubbereich f [mm/U] Feed rate f [mm/rev]	Bearbeitung Machining						
	<table border="1"> <tr> <td>P</td> <td>M</td> <td>K</td> </tr> <tr> <td>N</td> <td>S</td> <td>H</td> </tr> </table>	P	M	K	N	S	H	<p>↓ 0,02-0,10</p> <p>↔ 0,02-0,15</p>	
P	M	K							
N	S	H							
	<table border="1"> <tr> <td>P</td> <td>M</td> <td>K</td> </tr> <tr> <td>N</td> <td>S</td> <td>H</td> </tr> </table>	P	M	K	N	S	H	<p>↓ 0,05-0,15</p>	
P	M	K							
N	S	H							
	<table border="1"> <tr> <td>P</td> <td>M</td> <td>K</td> </tr> <tr> <td>N</td> <td>S</td> <td>H</td> </tr> </table>	P	M	K	N	S	H	<p>↓ 0,07-0,25</p>	
P	M	K							
N	S	H							
	<table border="1"> <tr> <td>P</td> <td>M</td> <td>K</td> </tr> <tr> <td>N</td> <td>S</td> <td>H</td> </tr> </table>	P	M	K	N	S	H	<p>↓ 0,02-0,08</p> <p>↔ 0,02-0,04</p>	
P	M	K							
N	S	H							
	<table border="1"> <tr> <td>P</td> <td>M</td> <td>K</td> </tr> <tr> <td>N</td> <td>S</td> <td>H</td> </tr> </table>	P	M	K	N	S	H	<p>↓ 0,03-0,15</p> <p>↔ 0,05-0,20</p>	
P	M	K							
N	S	H							



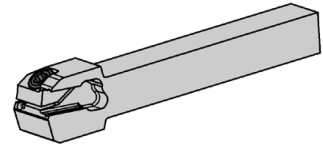
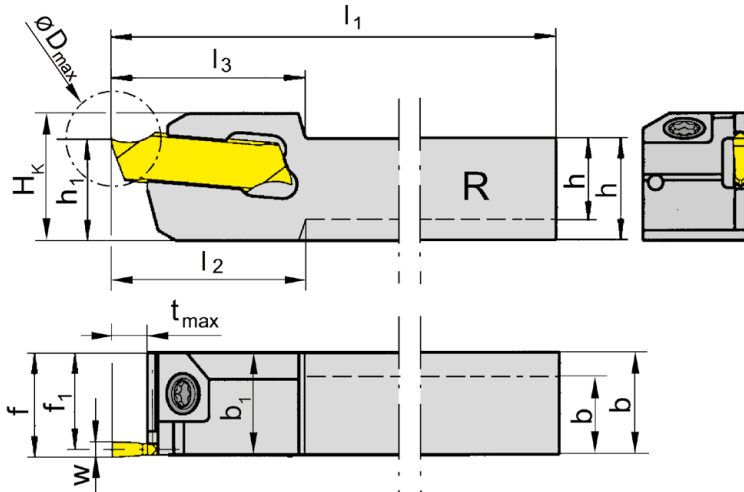
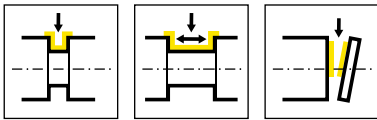

R = rechts wie gezeichnet
R = right hand version shown

L = links spiegelbildlich
L = left hand version

Bestellnummer Part number	h	b	l ₁	l ₂	l ₃	h ₁	b ₁	f ₁	f	t _{max}	D _{max}	H _K	HWS
RH264.0808.01	8	8	120	17,5	17,5	8	10	9,25	10	4	22	12,5	26401
RH264.1010.01	10	10	120	-	17,5	10	-	9,25	10	4	22	12,5	26401
RH264.1010.02	10	10	120	-	17,5	10	-	9	10	4	32	12,5	26402
RH264.1010.11	10	10	120	-	19	10	-	9,25	10	10	20	12,5	26401
RH264.1212.01	12	12	120	-	17,5	12	-	11,25	12	4	22	14,5	26401
RH264.1212.11	12	12	120	-	19	12	-	11,25	12	10	20	14,5	26401
RH264.1212.21	12	12	120	-	22	12	-	11,25	12	13	26	15,5	26401
RH264.1616.01	16	16	120	-	17,5	16	-	15,25	16	4	32	18,5	26401
RH264.1616.11	16	16	120	-	19	16	-	15,25	16	10	32	18,5	26401
RH264.1616.21	16	16	120	-	22	16	-	15,25	16	13	32	19,5	26401
LH264.0808.01	8	10	120	17,5	17,5	8	10	9,25	10	4	22	12,5	26401
LH264.1010.01	10	10	120	-	17,5	10	-	9,25	10	4	22	12,5	26401
LH264.1010.11	10	10	120	-	19	10	-	9,25	10	10	20	12,5	26401
LH264.1212.01	12	12	120	-	17,5	12	-	11,25	12	4	22	14,5	26401
LH264.1212.11	12	12	120	-	19	12	-	11,25	12	10	20	14,5	26401
LH264.1212.21	12	12	120	-	22	12	-	11,25	12	13	26	15,5	26401
LH264.1616.01	16	16	120	-	17,5	16	-	15,25	16	4	32	18,5	26401
LH264.1616.11	16	16	120	-	19	16	-	15,25	16	10	32	18,5	26401
LH264.1616.21	16	16	120	-	22	16	-	15,25	16	13	32	19,5	26401

w siehe Schneidplatten
w see inserts

Ersatzteile

Spare Parts

Klemmhalter Toolholder	Spannschraube Clamping Screw	TORX PLUS®-Schlüssel TORX PLUS® Wrench
R/LH264...	3.5.12T10EP	T10PL

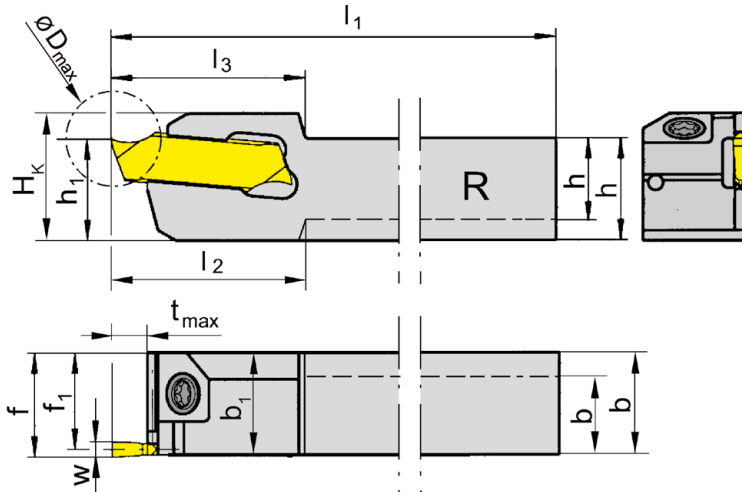
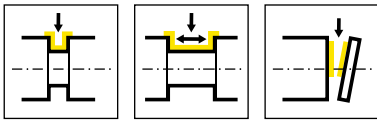

R = rechts wie gezeichnet
R = right hand version shown

L = links spiegelbildlich
L = left hand version

Bestellnummer Part number	h	b	l ₁	l ₃	h ₁	f ₁	f	t _{max}	D _{max}	H _k	HWS
RH264.1010.02	10	10	120	17,5	10	9	10	4	32	12,5	26402
RH264.1212.02	12	12	120	17,5	12	11	12	4	32	14,5	26402
RH264.1616.02	16	16	120	17,5	16	15	16	4	32	18,5	26402
RH264.1010.12	10	10	120	19	10	9	10	10	32	12,5	26402
RH264.1212.12	12	12	120	19	12	11	12	10	32	14,5	26402
RH264.1616.12	16	16	120	19	16	15	16	10	32	18,5	26402
RH264.1212.22	12	12	120	25	12	11	12	16	32	14,5	26402
RH264.1616.22	16	16	120	25	16	15	16	16	32	19,5	26402
LH264.1010.02	10	10	120	17,5	10	9	10	4	32	12,5	26402
LH264.1212.02	12	12	120	17,5	12	11	12	4	32	14,5	26402
LH264.1616.02	16	16	120	17,5	16	15	16	4	32	18,5	26402
LH264.1010.12	10	10	120	19	10	9	10	10	32	12,5	26402
LH264.1212.12	12	12	120	19	12	11	12	10	32	14,5	26402
LH264.1616.12	16	16	120	19	16	15	16	10	32	18,5	26402
LH264.1212.22	12	12	120	25	12	11	12	16	32	14,5	26402
LH264.1616.22	16	16	120	25	16	15	16	16	32	19,5	26402

w siehe Schneidplatten
w see inserts

Ersatzteile

Spare Parts

Klemmhalter Toolholder	Spannschraube Clamping Screw	TORX PLUS®-Schlüssel TORX PLUS® Wrench
R/LH264...	3.5.12T10EP	T10PL

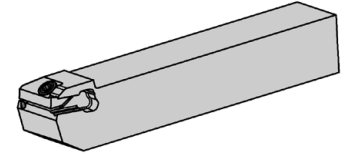
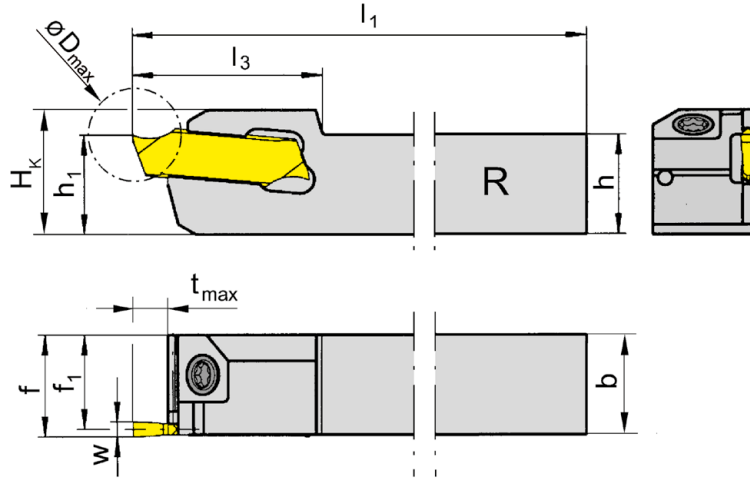
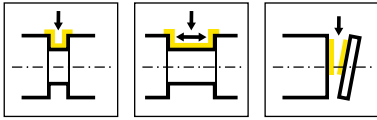

R = rechts wie gezeichnet
R = right hand version shown

L = links spiegelbildlich
L = left hand version

Bestellnummer Part number	h	b	l ₁	l ₃	h ₁	f ₁	f	t _{max}	D _{max}	H _K	HWS
RH264.1212.03	12	12	120	17,5	12	10,75	12	4	32	14,5	26403
RH264.1616.03	16	16	120	17,5	16	14,75	16	4	32	18,5	26403
RH264.1212.13	12	12	120	19	12	10,75	12	10	32	14,5	26403
RH264.1616.13	16	16	120	19	16	14,75	16	10	32	18,5	26403
RH264.1212.23	12	12	120	25	12	10,75	12	16	32	14,5	26403
RH264.1616.23	16	16	120	25	16	14,75	16	16	32	18,5	26403
LH264.1616.03	16	16	120	17,5	16	14,75	16	4	32	18,5	26403
LH264.1212.13	12	12	120	19	12	10,75	12	10	32	14,5	26403
LH264.1616.13	16	16	120	19	16	14,75	16	10	32	18,5	26403
LH264.1212.23	12	12	120	25	12	10,75	12	16	32	14,5	26403
LH264.1616.23	16	16	120	25	16	14,75	16	16	32	18,5	26403

w siehe Schneidplatten
w see inserts

Ersatzteile

Spare Parts

Klemmhalter Toolholder	Spannschraube Clamping Screw	TORX PLUS®-Schlüssel TORX PLUS® Wrench
R/LH264...	3.5.12T10EP	T10PL

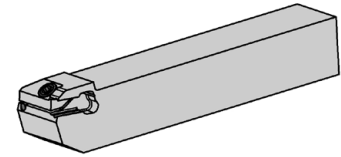
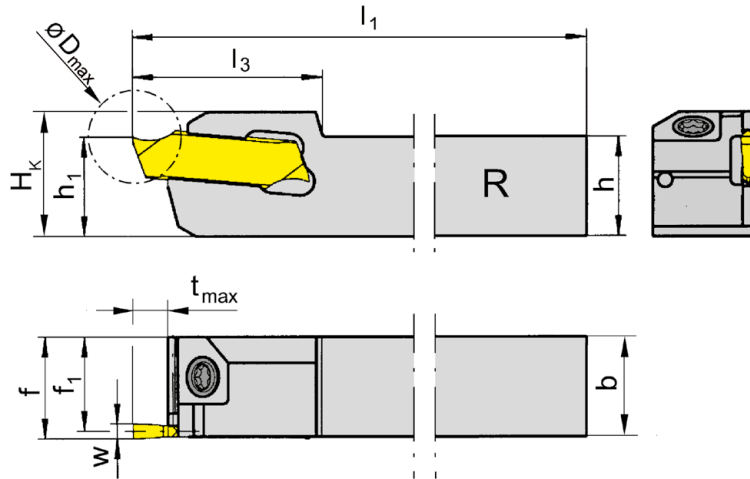
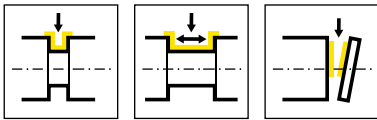

R = rechts wie gezeichnet
R = right hand version shown

L = links spiegelbildlich
L = left hand version

Bestellnummer Part number	h	b	l ₁	l ₃	h ₁	f ₁	f	t _{max}	D _{max}	H _K	HWS
RH264.1212.04	12	12	120	17,5	12	10,5	12	5	32	15	26404
RH264.1616.04	16	16	120	17,5	16	14,5	16	5	32	19	26404
RH264.1212.14	12	12	120	19	12	10,5	12	10	32	15	26404
RH264.1616.14	16	16	120	19	16	14,5	16	10	32	19	26404
RH264.1212.24	12	12	120	25	12	10,5	12	16	32	15	26404
RH264.1616.24	16	16	120	25	16	14,5	16	16	32	19	26404
LH264.1212.04	12	12	120	17,5	12	10,5	12	5	32	15	26404
LH264.1616.04	16	16	120	17,5	16	14,5	16	5	32	19	26404
LH264.1212.14	12	12	120	19	12	10,5	12	10	32	15	26404
LH264.1616.14	16	16	120	19	16	14,5	16	10	32	19	26404
LH264.1212.24	12	12	120	25	12	10,5	12	16	32	15	26404
LH264.1616.24	16	16	120	25	16	14,5	16	16	32	19	26404

w siehe Schneidplatten
w see inserts

Ersatzteile

Spare Parts

Klemmhalter Toolholder	Spannschraube Clamping Screw	TORX PLUS®-Schlüssel TORX PLUS® Wrench
R/LH264...	3.5.12T10EP	T10PL

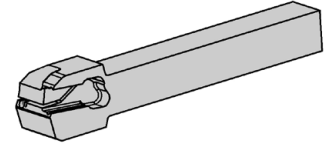
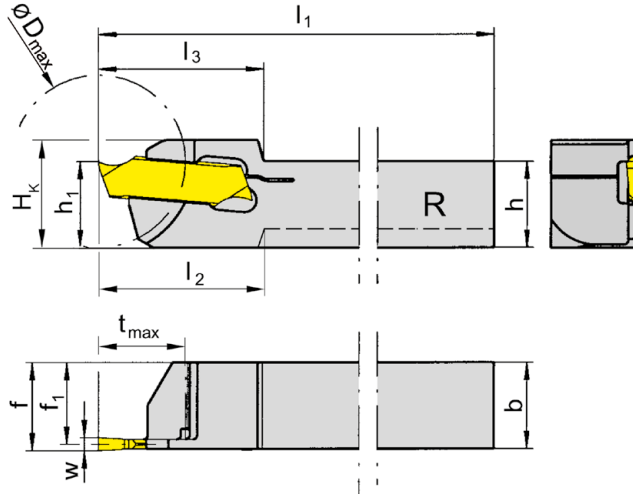
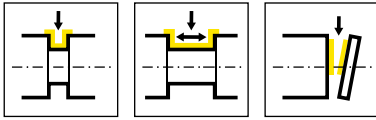

R = rechts wie gezeichnet
R = right hand version shown

L = links spiegelbildlich
L = left hand version

Bestellnummer Part number	h	b	l ₁	l ₂	l ₃	h ₁	f ₁	f	t _{max}	D _{max}	H _K	HWS
RH264.0808.51	8	8	120	18	18	10	7,25	8	7	20	12,5	26401
RH264.1010.61	10	10	120	-	19	10	9,25	10	10	20	12,5	26401
RH264.1010.62	10	10	120	-	19	10	9	10	10	20	12,5	26402
RH264.1212.62	12	12	120	-	19	12	11	12	10	20	14,5	26402
RH264.1212.63	12	12	120	-	19	12	10,75	12	10	32	14,5	26403
LH264.0808.51	8	8	120	18	18	10	7,25	8	7	20	12,5	26401
LH264.1010.61	10	10	120	-	19	10	9,25	10	10	20	12,5	26401
LH264.1010.62	10	10	120	-	19	10	9	10	10	20	12,5	26402
LH264.1212.62	12	12	120	-	19	12	11	12	10	20	14,5	26402
LH264.1212.63	12	12	120	-	19	12	10,75	12	10	32	14,5	26403
LH264.1212.64	12	12	120	-	19	12	10,5	12	10	32	14,5	26404

w siehe Schneidplatten
w see inserts

Der Schlüssel **P39L** gehört nicht zum Lieferumfang des Schneidenträgers. Bitte separat bestellen!
Wrench P39L is not combined with toolholder - separate order required!

Wendeschneidplatte

Indexable insert

264

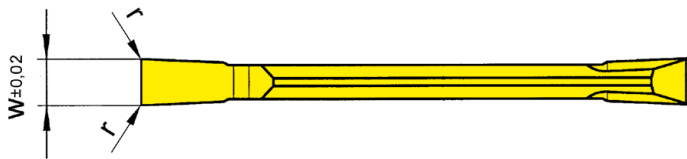
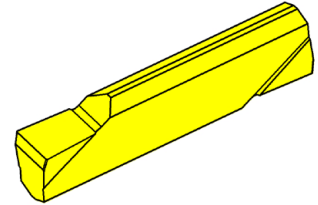
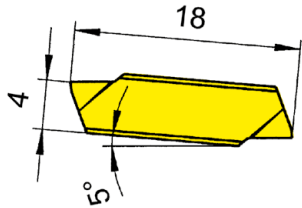
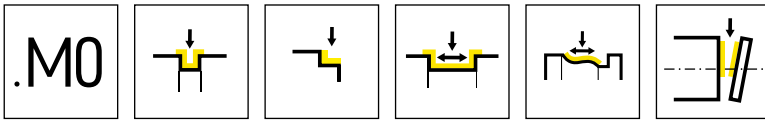

HM-Sorten
Carbide grades

▲ ab Lager
on stock

△ 4 Wochen
4 weeks

Bestellnummer Part number	w	r	HIS	HM-Sorten Carbide grades		
				MG12	TH35	TN35
264.0150.M0	1,5	0,05	26401	▲	△	▲
264.0200.M0	2	0,05	26402	▲	△	▲
264.0250.M0	2,5	0,1	26403	△	△	▲
264.0300.M0	3	0,1	26404	△	△	△
				P	o	•
				M	-	•
				K	-	•
				N	-	•
				S	-	•
				H	-	-

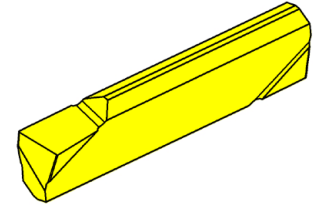
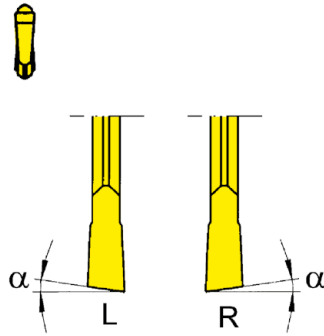
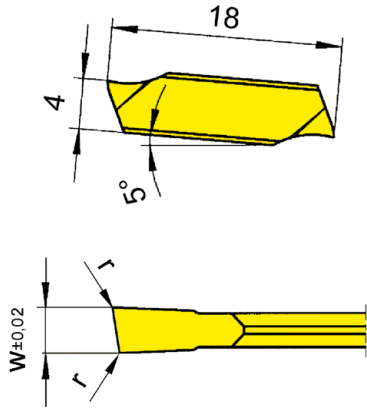
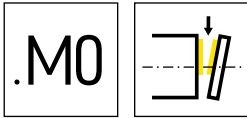

R = rechts wie gezeichnet
R = right hand version shown

L = links spiegelbildlich
L = left hand version

▲ ab Lager
on stock

HM-Sorten
Carbide grades
Δ 4 Wochen
4 weeks

Bestellnummer Part number	w	r	α	HIS	MG12	TH35	TN35
R264.0815.M0	1,5	0,05	8°	26401	Δ	Δ	▲
R264.1515.M0	1,5	0,05	15°	26401	▲	Δ	▲
R264.0820.M0	2	0,05	8°	26402	Δ	Δ	▲
R264.1520.M0	2	0,05	15°	26402	Δ	Δ	Δ
R264.0825.M0	2,5	0,1	8°	26403	Δ	Δ	Δ
R264.1525.M0	2,5	0,1	15°	26403	Δ	Δ	▲
R264.0830.M0	3	0,1	8°	26404	Δ	Δ	
R264.1530.M0	3	0,1	15°	26404	Δ	Δ	▲
L264.0815.M0	1,5	0,05	8°	26401	▲	Δ	▲
L264.1515.M0	1,5	0,05	15°	26401	▲	Δ	Δ
L264.0820.M0	2	0,05	8°	26402		Δ	Δ
L264.1520.M0	2	0,05	15°	26402	Δ	Δ	Δ
L264.0825.M0	2,5	0,1	8°	26403	Δ	Δ	Δ
L264.1525.M0	2,5	0,1	15°	26403	Δ		Δ
L264.0830.M0	3	0,1	8°	26404	Δ	Δ	
L264.1530.M0	3	0,1	15°	26404	Δ	Δ	Δ
P	o	●	●				
M	-	●	●				
K	-	●	●				
N	-	●	●				
S	-	●	●				
H	-	-	-				

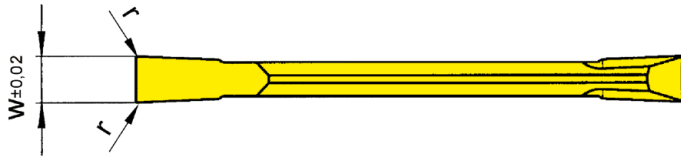
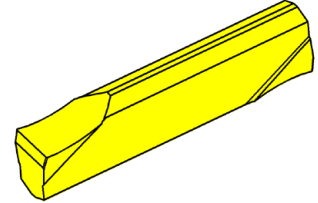
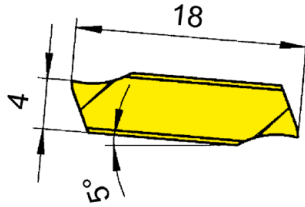
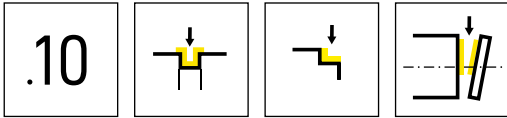

HM-Sorten
Carbide grades

▲ ab Lager
on stock

△ 4 Wochen
4 weeks

Bestellnummer Part number	w	r	HIS	HM-Sorten Carbide grades			
				MG12	TH35	TI25	TN35
264.0150.10	1,5	0,05	26401	▲	△	△	▲
264.0200.10	2	0,05	26402	▲	△	△	▲
264.0250.10	2,5	0,1	26403	△	△	△	▲
264.0300.10	3	0,1	26404	▲	△	△	▲
				P	o	•	•
				M	-	•	•
				K	-	•	•
				N	-	•	•
				S	-	•	•
				H	-	-	-

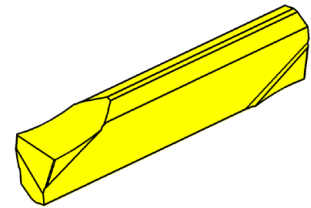
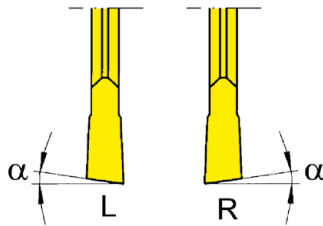
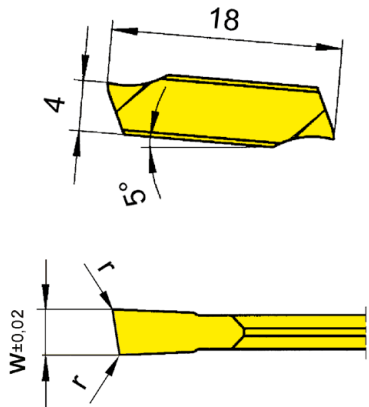
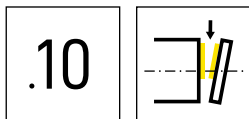

R = rechts wie gezeichnet
R = right hand version shown

L = links spiegelbildlich
L = left hand version

▲ ab Lager
on stock

HM-Sorten
Carbide grades
Δ 4 Wochen
4 weeks

Bestellnummer Part number	w	r	α	HIS	MG12	TH35	TI25	TN35
R264.0815.10	1,5	0,05	8°	26401	▲	Δ	Δ	▲
R264.1515.10	1,5	0,05	15°	26401	▲	Δ		▲
R264.0820.10	2	0,05	8°	26402	▲	Δ		▲
R264.1520.10	2	0,05	15°	26402	▲	Δ		▲
R264.0825.10	2,5	0,1	8°	26403	Δ	Δ		▲
R264.1525.10	2,5	0,1	15°	26403	Δ	Δ		▲
R264.0830.10	3	0,1	8°	26404	Δ	Δ		Δ
R264.1530.10	3	0,1	15°	26404	Δ	Δ		▲
L264.0815.10	1,5	0,05	8°	26401	Δ	Δ	Δ	▲
L264.1515.10	1,5	0,05	15°	26401	Δ	Δ		▲
L264.0820.10	2	0,05	8°	26402	Δ	Δ		▲
L264.1520.10	2	0,05	15°	26402	Δ	Δ		▲
L264.0825.10	2,5	0,1	8°	26403	Δ	Δ		Δ
L264.1525.10	2,5	0,1	15°	26403	Δ	Δ		Δ
L264.0830.10	3	0,1	8°	26404	Δ	Δ		Δ
L264.1530.10	3	0,1	15°	26404	Δ	Δ		▲
P	o	•	•	•				
M	-	•	•	•				
K	-	•	•	•				
N	-	•	•	•				
S	-	•	•	•				
H	-	-	-	-				

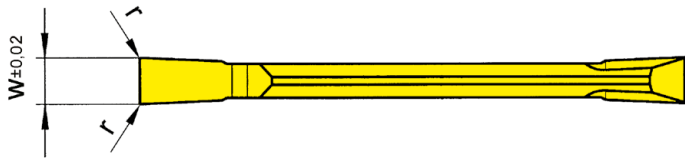
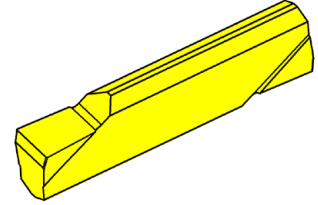
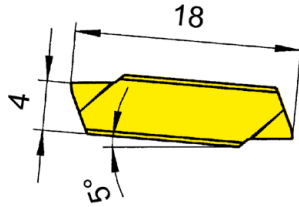
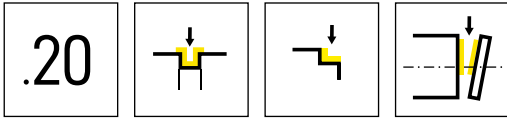

HM-Sorten
Carbide grades

▲ ab Lager
on stock

Δ 4 Wochen
4 weeks

Bestellnummer Part number	w	r	HIS	HM-Sorten Carbide grades			
				MG12	TH35	TI25	TN35
264.0150.20	1,5	0,05	26401	Δ	Δ	Δ	▲
264.0200.20	2	0,05	26402	Δ	Δ		▲
264.0250.20	2,5	0,1	26403	Δ	Δ		▲
264.0300.20	3	0,1	26404	Δ	Δ		▲
				P	o	•	•
				M	-	•	•
				K	-	•	•
				N	-	•	•
				S	-	•	•
				H	-	-	-

Wendeschnidplatte

Indexable insert

264

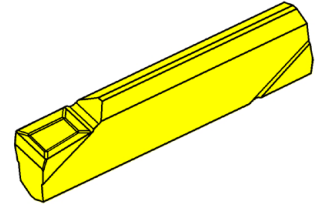
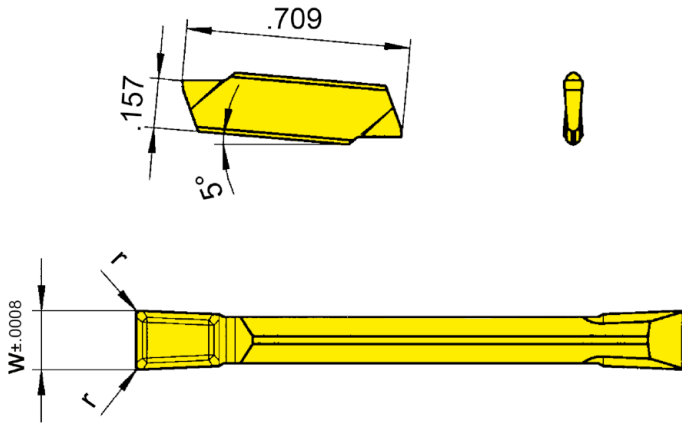
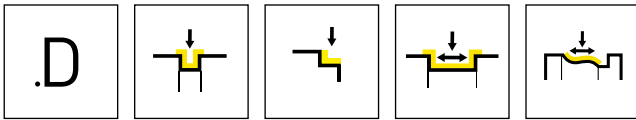

HM-Sorten
Carbide grades

▲ ab Lager
on stock

Δ 4 Wochen
4 weeks

Bestellnummer Part number	w	r	HIS	HM-Sorten	
				MG12	TN35
S264.0150.D1	1,5	0,05	26401		▲
S264.0200.D1	2	0,05	26402	Δ	▲
S264.0250.D1	2,5	0,1	26403	Δ	▲
S264.0300.D1	3	0,1	26404	Δ	▲
				P	●
				M	●
				K	●
				N	●
				S	●
				H	-

274



**Klemmhalter und
Schneidplatten**

**Toolholder and
Inserts**

J

Geometrien und
Vorschübe
Geometries and feed rates

Seite/Page
439

Klemmhalter
Toolholder
H274/RHC274/H274...E/
H274...SF

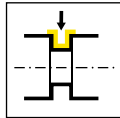

Seite/Page
440-441, 444,
446-447, 465

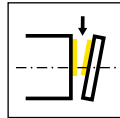

Seite/Page
442-443

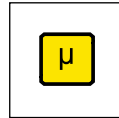

Seite/Page
482-483

Klemmhalter Graf
Toolholder Graf
974

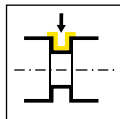

Seite/Page
445

Einbauhalter
Cartridge
KT274/KTC274

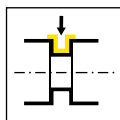

Seite/Page
448-449

Einbauhalter Graf
Cartridge Graf
76

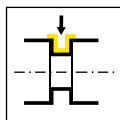

Seite/Page
450

Wendeschneidplatte
Indexable insert
S274/S274...E/S274...SF

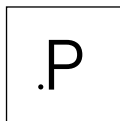

Seite/Page
451, 466

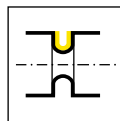

Seite/Page
452, 467

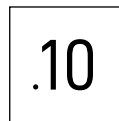

Seite/Page
453, 459-460,
468, 473-474



Seite/Page
454, 461-462,
469, 475, 477



Seite/Page
455, 463-464,
470, 478-479

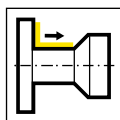

Seite/Page
456, 471

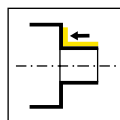

Seite/Page
457-458, 472,
476

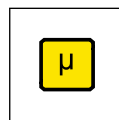

Seite/Page
484-490

Technische Hinweise
Technical Instructions
 μ -Finish

Seite/Page
480-481

Geometrien und Vorschübe

Geometries and feed rates



Geometrie Geometry	Werkstoff Material	Vorschubbereich f [mm/U] Feed rate f [mm/rev]	Bearbeitung Machining						
	<table border="1"> <tr> <td>P</td> <td>M</td> <td>K</td> </tr> <tr> <td>N</td> <td>S</td> <td>H</td> </tr> </table>	P	M	K	N	S	H	<p>↓ 0,02-0,08</p> <p>↔ 0,02-0,04</p>	
P	M	K							
N	S	H							
	<table border="1"> <tr> <td>P</td> <td>M</td> <td>K</td> </tr> <tr> <td>N</td> <td>S</td> <td>H</td> </tr> </table>	P	M	K	N	S	H	<p>↓ 0,05-0,15</p>	
P	M	K							
N	S	H							
	<table border="1"> <tr> <td>P</td> <td>M</td> <td>K</td> </tr> <tr> <td>N</td> <td>S</td> <td>H</td> </tr> </table>	P	M	K	N	S	H	<p>↓ 0,07-0,25</p>	
P	M	K							
N	S	H							
	<table border="1"> <tr> <td>P</td> <td>M</td> <td>K</td> </tr> <tr> <td>N</td> <td>S</td> <td>H</td> </tr> </table>	P	M	K	N	S	H	<p>↓ 0,02-0,10</p> <p>↔ 0,02-0,15</p>	
P	M	K							
N	S	H							
	<table border="1"> <tr> <td>P</td> <td>M</td> <td>K</td> </tr> <tr> <td>N</td> <td>S</td> <td>H</td> </tr> </table>	P	M	K	N	S	H	<p>↓ 0,002-0,01</p> <p>↔ 0,002-0,02</p>	
P	M	K							
N	S	H							

J

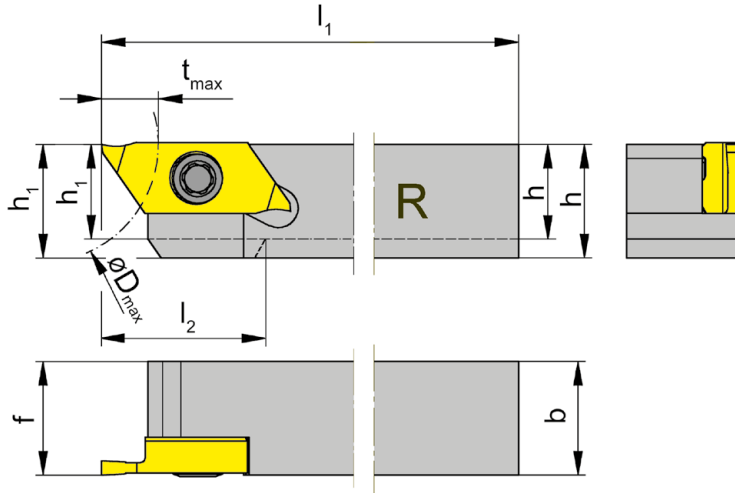
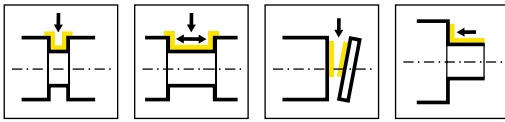

R = rechts wie gezeichnet
R = right hand version shown

L = links spiegelbildlich
L = left hand version

Bestellnummer Part number	h	b	l ₁	l ₂	h ₁	f	t _{max}	D _{max}	HWS
RH274.0808.04	8	8	100	16	8	8	6	25	274040R
RH274.1010.04	10	10	100	-	10	10	6	25	274040R
RH274.1212.04	12	12	100	-	12	12	6	25	274040R
RH274.1414.04	14	14	100	-	14	14	6	25	274040R
RH274.1616.04	16	16	125	-	16	16	6	25	274040R
RH274.2020.04	20	20	125	-	20	20	6	25	274040R
LH274.0808.04	8	8	100	16	8	8	6	25	274040L
LH274.1010.04	10	10	100	-	10	10	6	25	274040L
LH274.1212.04	12	12	100	-	12	12	6	25	274040L
LH274.1414.04	14	14	100	-	14	14	6	25	274040L
LH274.1616.04	16	16	125	-	16	16	6	25	274040L
LH274.2020.04	20	20	125	-	20	20	6	25	274040L

Bei Schaftabmessung 8 x 8 mm, Klemmhalter mit Absetzung am Kopf.
For shank dimension 8 x 8 mm toolholder with offset at the head.

J

Ersatzteile
Spare Parts

Klemmhalter Toolholder	Spannschraube Clamping Screw	TORX PLUS®-Schlüssel TORX PLUS® Wrench
R/LH274.0808.04	030.350P.0744	T15PQ
R/LH274...	030.3509.T15P	T15PQ

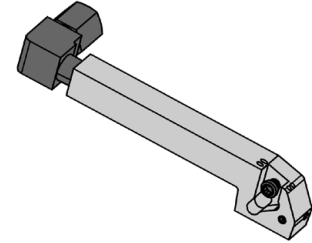
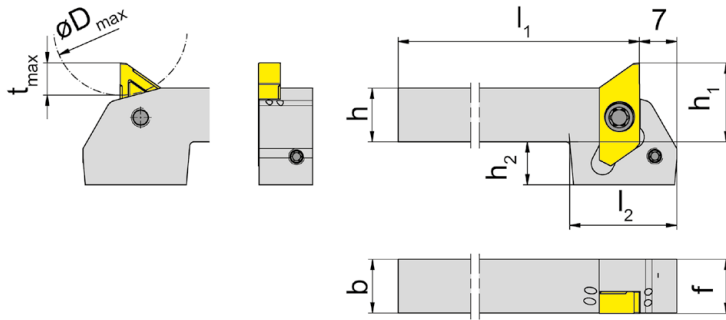
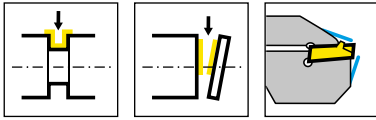

L = links wie gezeichnet
L = left hand version shown

Bestellnummer Part number	h	b	l ₁	l ₂	h ₁	f	t _{max}	D _{max}	h ₂	HWS
LH274.1010.3.Y.6.24.IK	10	10	73	20	14,7	10	6	25	8	274040L
LH274.1010.4.Y.6.24.IK	10	10	93	20	14,7	10	6	25	8	274040L
LH274.1212.3.Y.6.24.IK	12	12	73	20	16,7	12	6	25	6	274040L
LH274.1212.4.Y.6.24.IK	12	12	93	20	16,7	12	6	25	6	274040L
LH274.1616.3.Y.6.24.IK	16	16	73	20	20,7	16	6	25	2	274040L
LH274.1616.4.Y.6.24.IK	16	16	93	20	20,7	16	6	25	2	274040L

Ersatzteile
Spare Parts

Klemmhalter Toolholder	Kühlmittelanschluss Coolant supply	Spannschraube Clamping Screw	TORX PLUS®-Schlüssel TORX PLUS® Wrench	Verschlusschraube Screw Plug
LH274....	004.00.22	030.3509.T15P	T15PQ	
LH274.1616...	004.00.16	030.3509.T15P	T15PQ	004.00.26



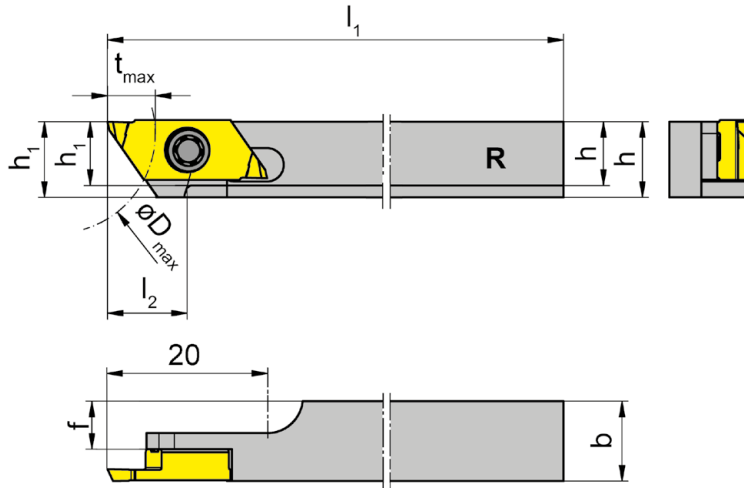
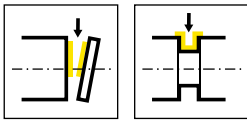

R = rechts wie gezeichnet
R = right hand version shown

Bestellnummer Part number	h	b	l ₁	l ₂	h ₁	f	t _{max}	D _{max}	HWS
RH274.0808.6.04	8	8	100	10	9,5	4	6	25	274040R
RH274.1010.6.04	10	10	100	10	9,5	6	6	25	274040R
RH274.1212.6.04	12	12	100	10	9,5	8	6	25	274040R

Bei Schaftabmessung 8 x 8 mm, Klemmhalter mit Absetzung am Kopf.
For shank dimension 8 x 8 mm toolholder with offset at the head.

Ersatzteile
Spare Parts

Klemmhalter Toolholder	Spannschraube Clamping Screw	TORX PLUS®-Schlüssel TORX PLUS® Wrench
RH274...	030.350P.0981	T15PQ

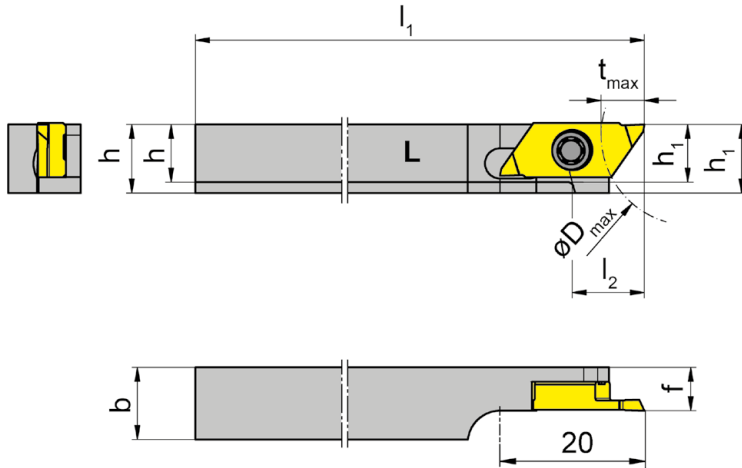
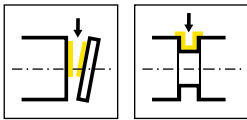

L = links wie gezeichnet
L = left hand version shown

Bestellnummer Part number	h	b	l ₁	l ₂	h ₁	f	t _{max}	D _{max}	HWS
LH274.0808.6.04.M	8	8	100	10	9,5	6	6	25	274040L
LH274.1010.6.04.M	10	10	100	10	9,5	6	6	25	274040L
LH274.1212.6.04.M	12	12	100	10	9,5	6	6	25	274040L

Bei Schaftabmessung 8 x 8 mm, Klemmhalter mit Absetzung am Kopf.
For shank dimension 8 x 8 mm toolholder with offset at the head.

Ersatzteile
Spare Parts

Klemmhalter Toolholder	Spannschraube Clamping Screw	TORX PLUS®-Schlüssel TORX PLUS® Wrench
LH274...	030.350P.0981	T15PQ



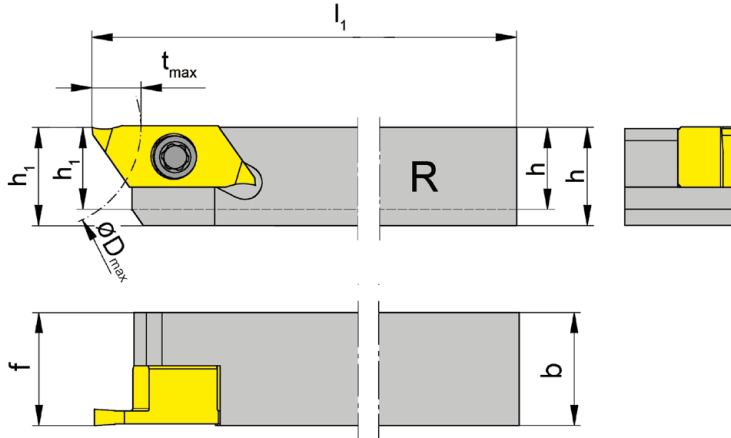
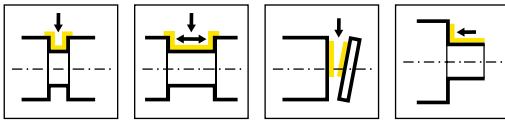

R = rechts wie gezeichnet
R = right hand version shown

L = links spiegelbildlich
L = left hand version

Bestellnummer Part number	h	b	l ₁	h ₁	f	t _{max}	D _{max}	HWS
RH274.1214.07	12	14	100	12	14	6	25	274070R
RH274.1616.07	16	16	125	16	16	6	25	274070R
LH274.1214.07	12	14	100	12	14	6	25	274070L
LH274.1616.07	16	16	125	16	16	6	25	274070L

Klemmhalter für Sonderbreiten bzw. Formplatten
Toolholder for special widths resp. special insert shapes

Ersatzteile
Spare Parts

Klemmhalter Toolholder	Spannschraube Clamping Screw	TORX PLUS®-Schlüssel TORX PLUS® Wrench
R/LH274...	030.3513.T15P	T15PQ

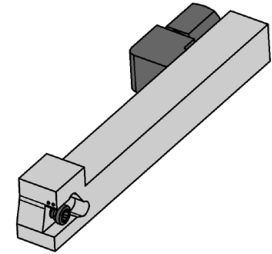
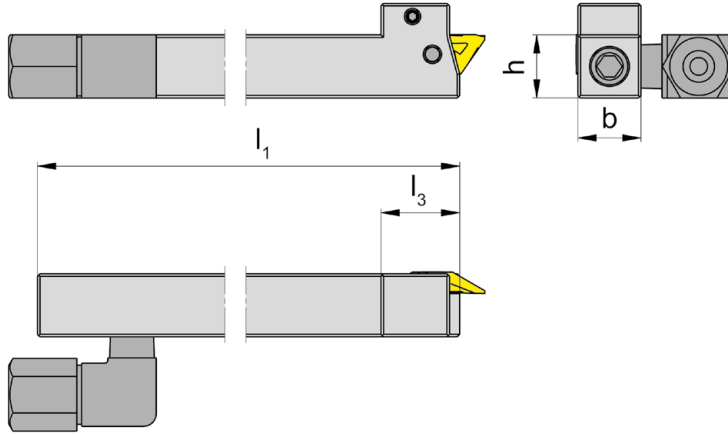
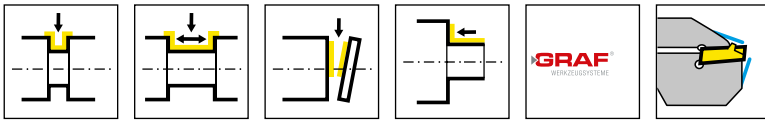

R = rechts wie gezeichnet
R = right hand version shown

L = links spiegelbildlich
L = left hand version

Bestellnummer Part number	h	b	l ₁	l ₃	HWS
974.L.1012.04.1K	10	12	100	15	274040L
974.L.1212.04.1K	12	12	100	15	274040L
974.L.1616.04.1K	16	16	100	15	274040L
974.L.2020.04.1K	20	20	100	15	274040L
974.L.2020.04.2IK	20	20	100	15	274040L
974.R.1012.04.1K	10	12	100	15	274040R
974.R.1212.04.1K	12	12	100	15	274040R
974.R.1616.04.1K	16	16	100	15	274040R
974.R.2020.04.1K	20	20	100	15	274040R

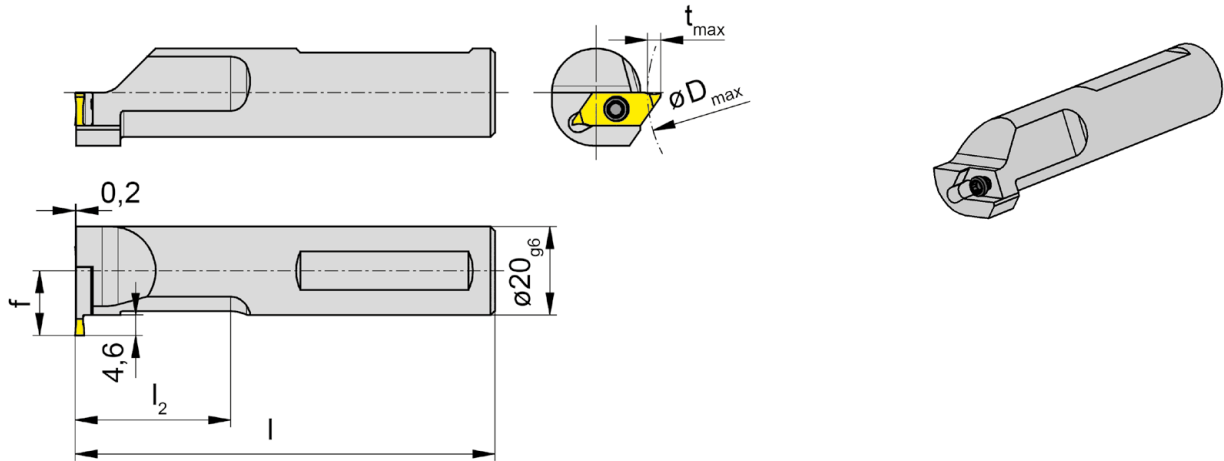
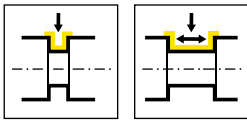

R = rechts wie gezeichnet
R = right hand version shown

Bestellnummer Part number	l	l ₂	f	t _{max}	HWS	HMS
RHC274.0020.1.04	95	35	14,6	6	274040L	Index Traub

Stechtiefe in Abhängigkeit des Werkstück-ø
Depth of groove in relation to workpiece ø

Dmax	tmax
40	2
60	3
120	3,5

J

Ersatzteile
Spare Parts

Klemmhalter Toolholder	Spannschraube Clamping Screw	TORX PLUS®-Schlüssel TORX PLUS® Wrench
RHC274.0020.1.04	030.3509.T15P	T15PQ

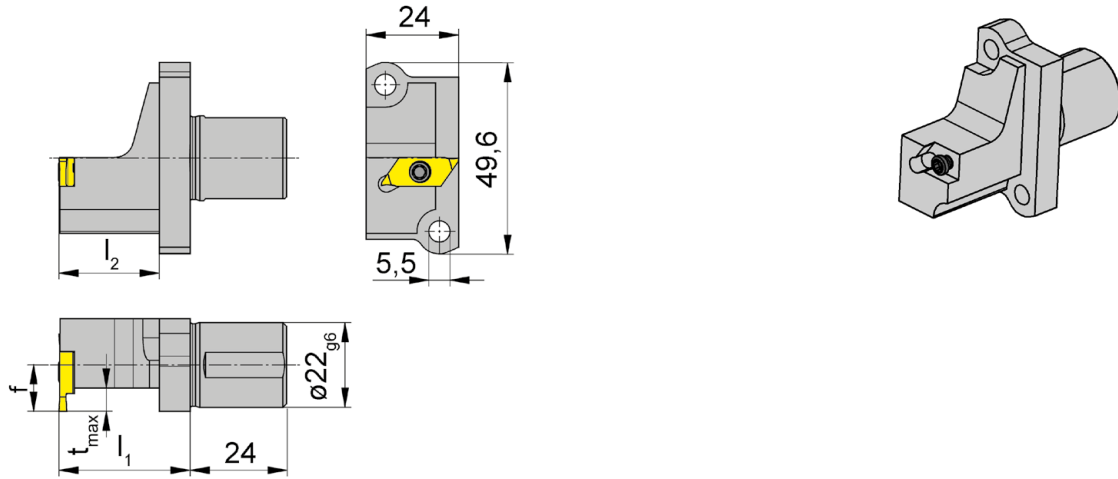
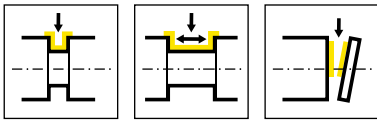

R = rechts wie gezeichnet
R = right hand version shown

L = links spiegelbildlich
L = left hand version

Bestellnummer Part number	f	l ₁	t _{max}	l ₂	HWS	HMS
RH274.A022.09.04	9	34	6	26	274040R	Star
RH274.A022.12.04	12	34	6	26	274040R	Star
RH274.A022.16.04	16	34	6	26	274040R	Star
RH274.A022.12.07	12	34	6	26	274070R	Star
LH274.A022.09.04	9	34	6	26	274040L	Star
LH274.A022.16.04	16	34	6	26	274040L	Star
LH274.A022.09.07	9	34	6	26	274070L	Star
LH274.A022.12.07	12	34	6	26	274070L	Star

für Star Langdrehautomaten
for Swiss type machines Star

Ersatzteile
Spare Parts

Klemmhalter Toolholder	Spannschraube Clamping Screw	TORX PLUS®-Schlüssel TORX PLUS® Wrench
R/LH274...	030.3513.T15P	T15PQ



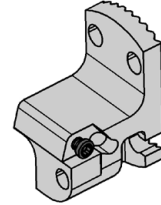
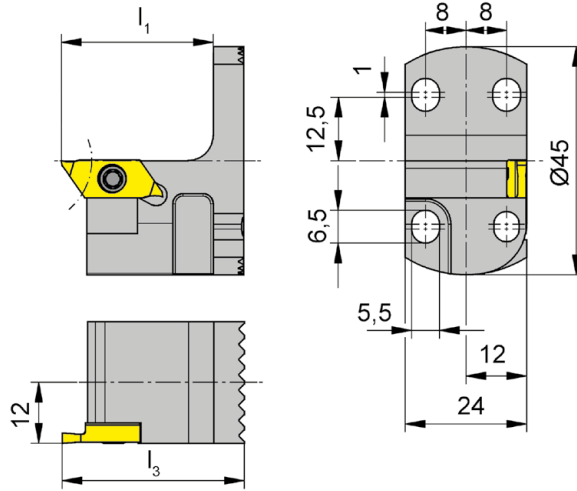
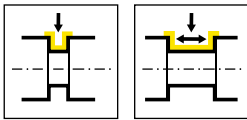

R = rechts wie gezeichnet
R = right hand version shown

L = links spiegelbildlich
L = left hand version

Bestellnummer Part number	l_3	l_1	HWS
RKT274.2445.04	36	30	274040R
LKT274.2445.04	36	30	274040L

Ersatzteile
Spare Parts

Einbauhalter Cartridge	Spannschraube Clamping Screw	TORX PLUS®-Schlüssel TORX PLUS® Wrench
R/LKT274.2445.04	030.3509.T15P	T15PQ

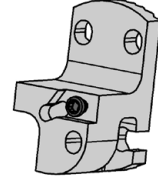
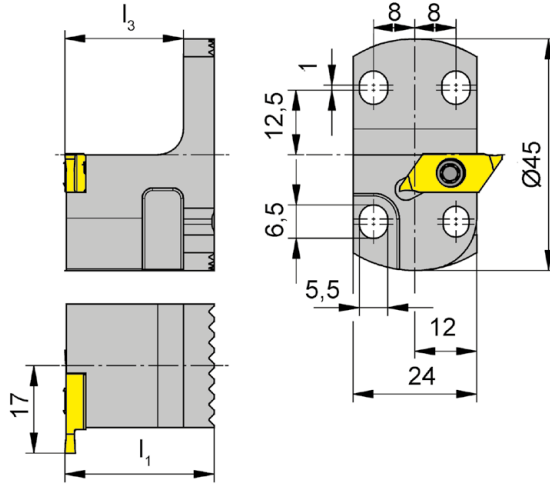
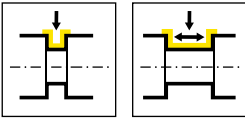

R = rechts wie gezeichnet
R = right hand version shown

Bestellnummer Part number	l_1	l_3	HWS
RKTC274.2445.04	29	23	274040R

Ersatzteile
Spare Parts

Einbauhalter Cartridge	Spannschraube Clamping Screw	TORX PLUS®-Schlüssel TORX PLUS® Wrench
RKTC274.2445.04	030.3509.T15P	T15PQ



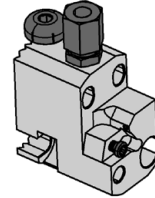
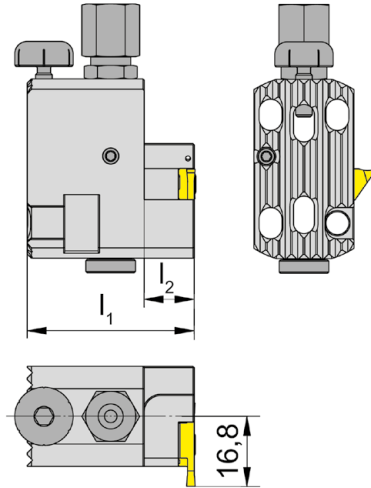
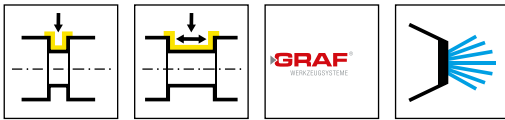

R = rechts wie gezeichnet
R = right hand version shown

Bestellnummer Part number	l_1	l_2	HWS
R.76.IK	40	12	274040R

J

Ersatzteile
Spare Parts

Einbauhalter Graf Cartridge Graf	Kühlmittelanschluss Coolant supply	Spannschraube Clamping Screw	TORX PLUS®-Schlüssel TORX PLUS® Wrench
R.76.IK	004.00.19	030.3509.T15P	T15PQ

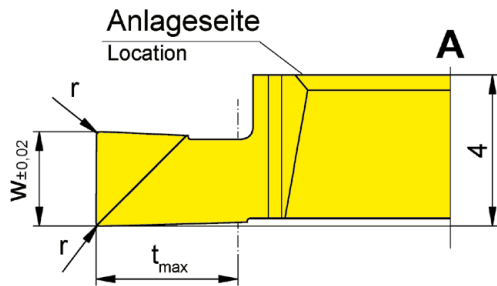
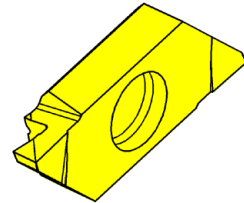
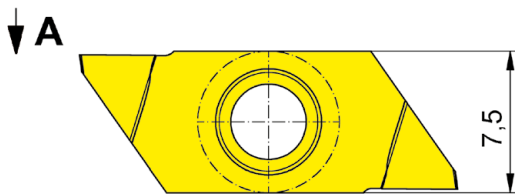
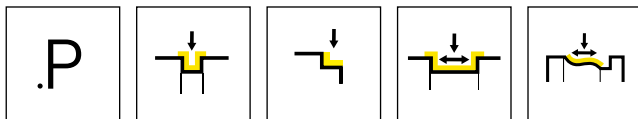

R = rechts wie gezeichnet
R = right hand version shown

L = links spiegelbildlich
L = left hand version

▲ ab Lager
on stock

HM-Sorten
Carbide grades
Δ 4 Wochen
4 weeks

Bestellnummer Part number	w	r	t _{max}	HIS	IG35	TH35
RS274.0050.P0	0,5	-	1	274040R	▲	▲
RS274.0100.P0	1	-	2	274040R	▲	▲
RS274.0150.P0	1,5	0,05	2,25	274040R	▲	▲
RS274.0200.P0	2	0,05	3	274040R	▲	▲
RS274.0250.P0	2,5	0,1	3,75	274040R	▲	▲
RS274.0300.P0	3	0,1	4,5	274040R	▲	▲
LS274.0050.P0	0,5	-	1	274040L	▲	▲
LS274.0100.P0	1	-	2	274040L	▲	▲
LS274.0150.P0	1,5	0,05	2,25	274040L	▲	▲
LS274.0200.P0	2	0,05	3	274040L	Δ	▲
LS274.0250.P0	2,5	0,1	3,75	274040L	▲	▲
LS274.0300.P0	3	0,1	4,5	274040L	Δ	▲
					P	•
					M	•
					K	•
					N	•
					S	•
					H	-

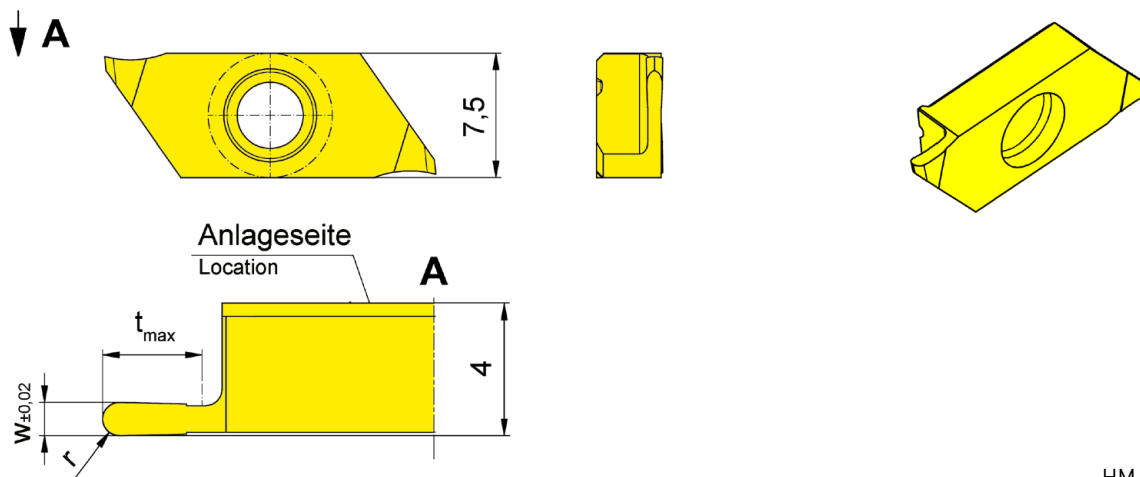
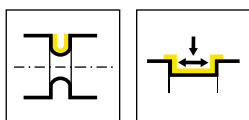

R = rechts wie gezeichnet
R = right hand version shown

L = links spiegelbildlich
L = left hand version

▲ ab Lager
on stock

HM-Sorten
Carbide grades
Δ 4 Wochen
4 weeks

Bestellnummer Part number	w	t _{max}	r	HIS	IG35	TH35
RS274.0205.01.10	0,5	1,5	0,25	274040R	▲	▲
RS274.0510.03.10	1	3	0,5	274040R	▲	▲
RS274.1020.04.10	2	4	1	274040R	▲	▲
LS274.0205.01.10	0,5	1,5	0,25	274040L	▲	▲
LS274.0510.03.10	1	3	0,5	274040L	▲	▲
LS274.1020.04.10	2	4	1	274040L	Δ	▲
					P	- ●
					M	● ●
					K	- ●
					N	- ●
					S	● ●
					H	- -

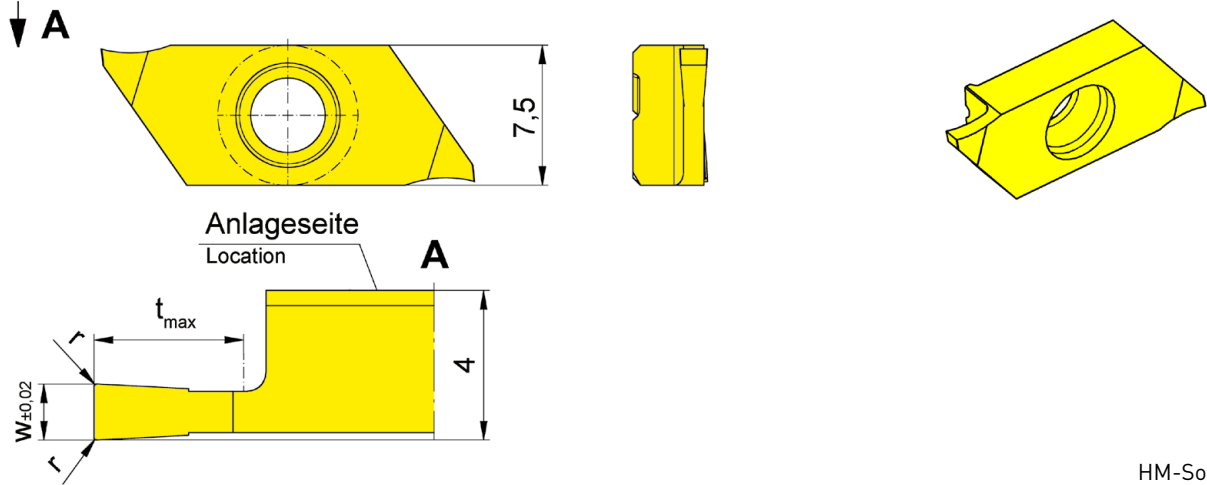
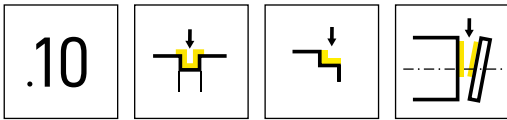

R = rechts wie gezeichnet
R = right hand version shown

L = links spiegelbildlich
L = left hand version

▲ ab Lager
on stock

HM-Sorten
Carbide grades
Δ 4 Wochen
4 weeks

Bestellnummer Part number	w	r	t _{max}	HIS	IG35	TH35
RS274.0050.01.10	0,5	0,05	1,5	274040R	▲	▲
RS274.0070.02.10	0,7	0,05	2	274040R	▲	▲
RS274.0080.03.10	0,8	0,05	3	274040R	▲	▲
RS274.0100.03.10	1	0,05	3	274040R	▲	▲
RS274.0120.03.10	1,2	0,05	3	274040R	▲	▲
RS274.0150.04.10	1,5	0,05	4	274040R	▲	▲
RS274.0150.06.10	1,5	0,05	6	274040R	▲	▲
RS274.0200.04.10	2	0,05	4	274040R	▲	▲
RS274.0200.06.10	2	0,05	6	274040R	▲	▲
LS274.0050.01.10	0,5	0,05	1,5	274040L	▲	▲
LS274.0070.02.10	0,7	0,05	2	274040L	Δ	Δ
LS274.0080.03.10	0,8	0,05	3	274040L	▲	▲
LS274.0100.03.10	1	0,05	3	274040L	▲	▲
LS274.0120.03.10	1,2	0,05	3	274040L	▲	▲
LS274.0150.04.10	1,5	0,05	4	274040L	▲	▲
LS274.0150.06.10	1,5	0,05	6	274040L	▲	▲
LS274.0200.04.10	2	0,05	4	274040L	▲	▲
LS274.0200.06.10	2	0,05	6	274040L	▲	▲
P	-	●				
M	●	●				
K	-	●				
N	-	●				
S	●	●				
H	-	-				

J

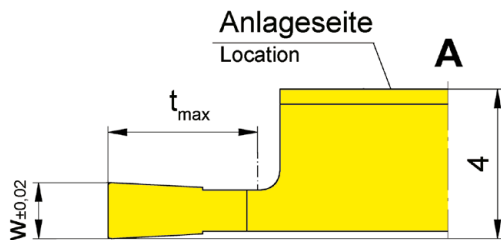
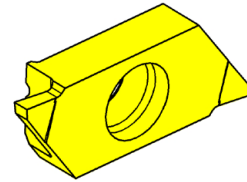
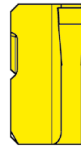
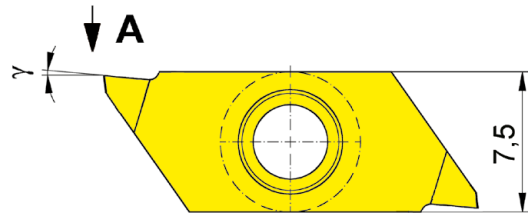
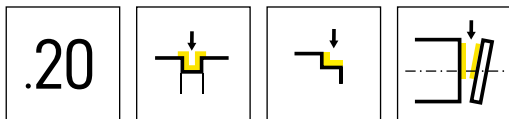

R = rechts wie gezeichnet
R = right hand version shown

L = links spiegelbildlich
L = left hand version

▲ ab Lager
on stock

HM-Sorten
Carbide grades
Δ 4 Wochen
4 weeks

Bestellnummer Part number	w	t _{max}	γ	HIS	IG35	TH35
RS274.0050.01.20	0,5	1,5	5°	274040R	▲	▲
RS274.0070.02.20	0,7	2	5°	274040R	Δ	▲
RS274.0080.03.20	0,8	3	5°	274040R	Δ	▲
RS274.0100.03.20	1	3	5°	274040R	▲	▲
RS274.0120.03.20	1,2	3	5°	274040R	Δ	▲
RS274.0150.04.20	1,5	4	5°	274040R	▲	▲
RS274.0150.06.20	1,5	6	5°	274040R	Δ	Δ
RS274.0200.04.20	2	4	5°	274040R	Δ	▲
RS274.0200.06.20	2	6	5°	274040R	Δ	▲
LS274.0050.01.20	0,5	1,5	5°	274040L	Δ	▲
LS274.0070.02.20	0,7	2	5°	274040L	Δ	▲
LS274.0080.03.20	0,8	3	5°	274040L	Δ	Δ
LS274.0100.03.20	1	3	5°	274040L	Δ	Δ
LS274.0120.03.20	1,2	3	5°	274040L	Δ	Δ
LS274.0150.04.20	1,5	4	5°	274040L	▲	▲
LS274.0150.06.20	1,5	6	5°	274040L	Δ	▲
LS274.0200.04.20	2	4	5°	274040L	Δ	Δ
LS274.0200.06.20	2	6	5°	274040L	Δ	Δ
P	-	●				
M	●	●				
K	-	●				
N	-	●				
S	●	●				
H	-	-				

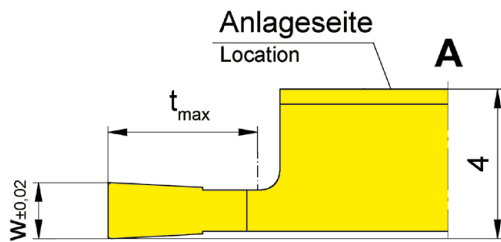
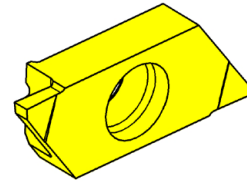
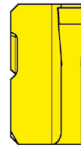
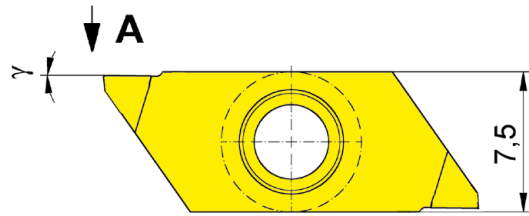
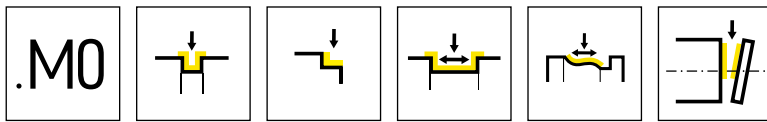

R = rechts wie gezeichnet
R = right hand version shown

L = links spiegelbildlich
L = left hand version

▲ ab Lager
on stock

HM-Sorten
Carbide grades
Δ 4 Wochen
4 weeks

Bestellnummer Part number	w	t _{max}	γ	HIS	IG35	TH35
RS274.0050.01.M0	0,5	1,5	0°	274040R	Δ	▲
RS274.0070.02.M0	0,7	2	0°	274040R	Δ	Δ
RS274.0080.03.M0	0,8	3	0°	274040R	Δ	Δ
RS274.0100.03.M0	1	3	0°	274040R	Δ	▲
RS274.0120.03.M0	1,2	3	0°	274040R	Δ	▲
RS274.0150.04.M0	1,5	4	0°	274040R	Δ	Δ
RS274.0150.06.M0	1,5	6	0°	274040R	Δ	Δ
RS274.0200.04.M0	2	4	0°	274040R	Δ	Δ
RS274.0200.06.M0	2	6	0°	274040R	Δ	▲
LS274.0050.01.M0	0,5	1,5	0°	274040L	Δ	Δ
LS274.0070.02.M0	0,7	2	0°	274040L	▲	
LS274.0080.03.M0	0,8	3	0°	274040L	Δ	Δ
LS274.0100.03.M0	1	3	0°	274040L	Δ	Δ
LS274.0120.03.M0	1,2	3	0°	274040L	Δ	Δ
LS274.0150.04.M0	1,5	4	0°	274040L	Δ	Δ
LS274.0150.06.M0	1,5	6	0°	274040L	Δ	Δ
LS274.0200.04.M0	2	4	0°	274040L	Δ	Δ
LS274.0200.06.M0	2	6	0°	274040L	Δ	Δ
P	-	●				
M	●	●				
K	-	●				
N	-	●				
S	●	●				
H	-	-				

J

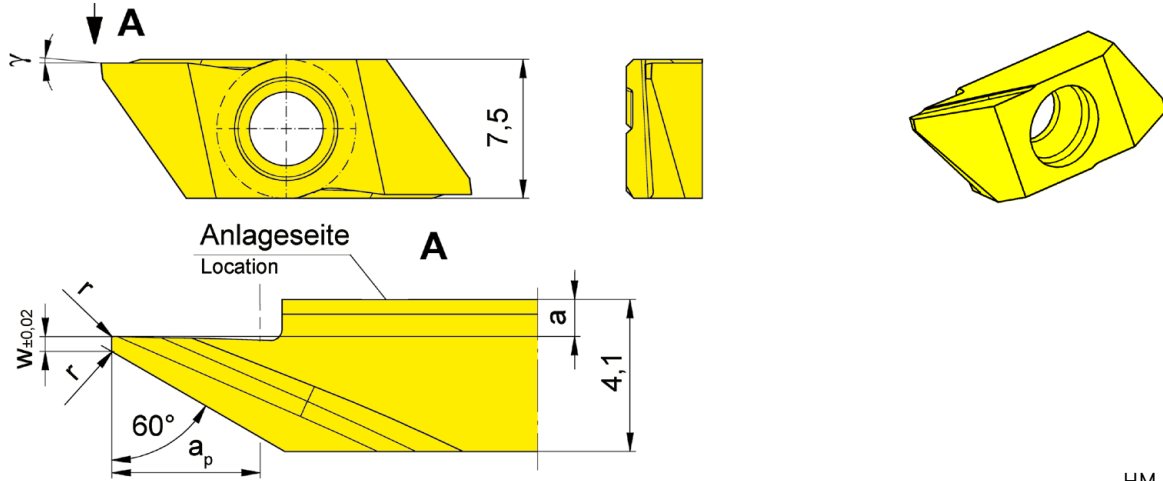
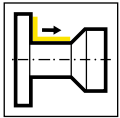

R = rechts wie gezeichnet
R = right hand version shown

L = links spiegelbildlich
L = left hand version

▲ ab Lager
on stock

HM-Sorten
Carbide grades
Δ 4 Wochen
4 weeks

Bestellnummer Part number	w	r	a	γ	a _p	HIS		K10	IG35	TH35
RS274.0060.04.10	-	0,05	1	15°	4	274040R			▲	▲
RS274.0460.04.10	0,4	0,05	1	15°	4	274040R			▲	▲
RS274.0460.04.M0	0,4	0,05	1	0°	4	274040R	▲	Δ	Δ	
RS274.0560.06.11	0,5	0,1	0,05	15°	6	274040R			▲	▲
LS274.0060.04.10	-	0,05	1	15°	4	274040L			Δ	Δ
LS274.0460.04.10	0,4	0,05	1	15°	4	274040L			▲	▲
LS274.0460.04.M0	0,4	0,05	1	0°	4	274040L	Δ	Δ	Δ	
LS274.0560.06.11	0,5	0,1	0,05	15°	6	274040L			▲	▲
							P	●	-	●
							M	○	●	●
							K	●	-	●
							N	●	-	●
							S	○	●	●
							H	-	-	-

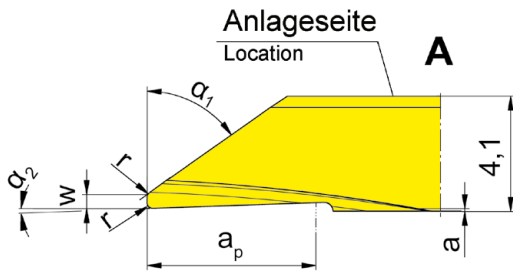
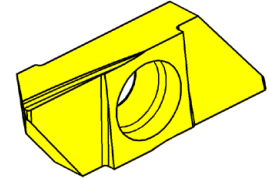
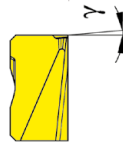
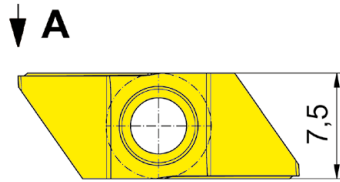
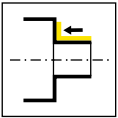

R = rechts wie gezeichnet
R = right hand version shown

L = links spiegelbildlich
L = left hand version

▲ ab Lager
on stock

HM-Sorten
Carbide grades
Δ 4 Wochen
4 weeks

Bestellnummer Part number	w	r	α_1	a	γ	a_p	α_2	HIS	IG35	TH35
RS274.0035.04.20	-	0,05	35°	0,1	5°	4	0°	274040R	▲	▲
RS274.0055.04.20	-	0,05	55°	0,1	5°	4	0°	274040R	Δ	▲
RS274.0235.04.20	0,2	-	35°	0,1	5°	4	0°	274040R	▲	▲
RS274.0255.04.20	0,2	-	55°	0,1	5°	4	0°	274040R	Δ	▲
RS274.0535.06.20	0,5	0,2	35°	0,1	5°	6	0°	274040R	▲	▲
RS274.0555.06.20	0,5	0,2	55°	0,1	5°	6	0°	274040R	▲	▲
LS274.0035.04.20	-	0,05	35°	0,1	5°	4	0°	274040L	Δ	Δ
LS274.0055.04.20	-	0,05	55°	0,1	5°	4	0°	274040L	Δ	▲
LS274.0235.04.20	0,2	-	35°	0,1	5°	4	0°	274040L	Δ	▲
LS274.0255.04.20	0,2	-	55°	0,1	5°	4	0°	274040L	Δ	Δ
LS274.0535.06.20	0,5	0,2	35°	0,1	5°	6	0°	274040L	Δ	Δ
LS274.0555.06.20	0,5	0,2	55°	0,1	5°	6	0°	274040L	▲	▲
	P	-	●							
	M	●	●							
	K	-	●							
	N	-	●							
	S	●	●							
	H	-	-							

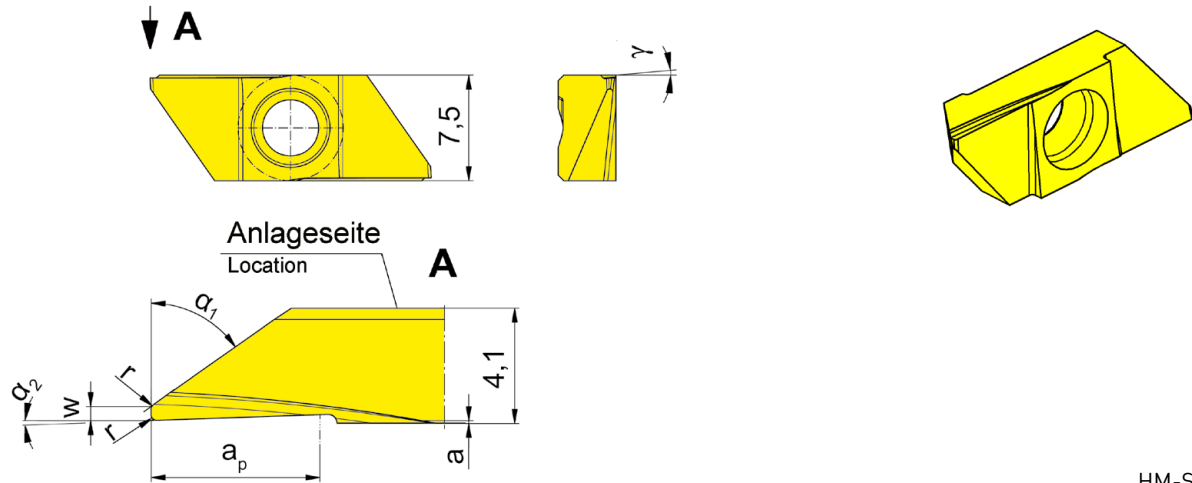
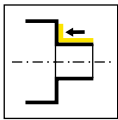

R = rechts wie gezeichnet
R = right hand version shown

L = links spiegelbildlich
L = left hand version

▲ ab Lager
on stock

HM-Sorten
Carbide grades
Δ 4 Wochen
4 weeks

Bestellnummer Part number	w	r	α_1	a	γ	a_p	α_2	HIS	IG35	TH35
RS274.0035.24.20	-	0,05	35°	0,1	5°	4	2°	274040R	▲	▲
RS274.0235.24.20	0,2	-	35°	0,1	5°	4	2°	274040R	Δ	▲
RS274.0535.26.20	0,5	0,2	35°	0,1	5°	6	2°	274040R	▲	▲
RS274.0055.24.20	-	0,05	55°	0,1	5°	4	2°	274040R	Δ	▲
RS274.0255.24.20	0,2	-	55°	0,1	5°	4	2°	274040R	Δ	▲
RS274.0555.26.20	0,5	0,2	55°	0,1	5°	6	2°	274040R	Δ	▲
LS274.0035.24.20	-	0,05	35°	0,1	5°	4	2°	274040L	Δ	Δ
LS274.0235.24.20	0,2	-	35°	0,1	5°	4	2°	274040L	▲	Δ
LS274.0535.26.20	0,5	0,2	35°	0,1	5°	6	2°	274040L	▲	▲
LS274.0055.24.20	-	0,05	55°	0,1	5°	4	2°	274040L	▲	▲
LS274.0255.24.20	0,2	-	55°	0,1	5°	4	2°	274040L	Δ	Δ
LS274.0555.26.20	0,5	0,2	55°	0,1	5°	6	2°	274040L	Δ	Δ
P	-	●								
M	●	●								
K	-	●								
N	-	●								
S	●	●								
H	-	-								

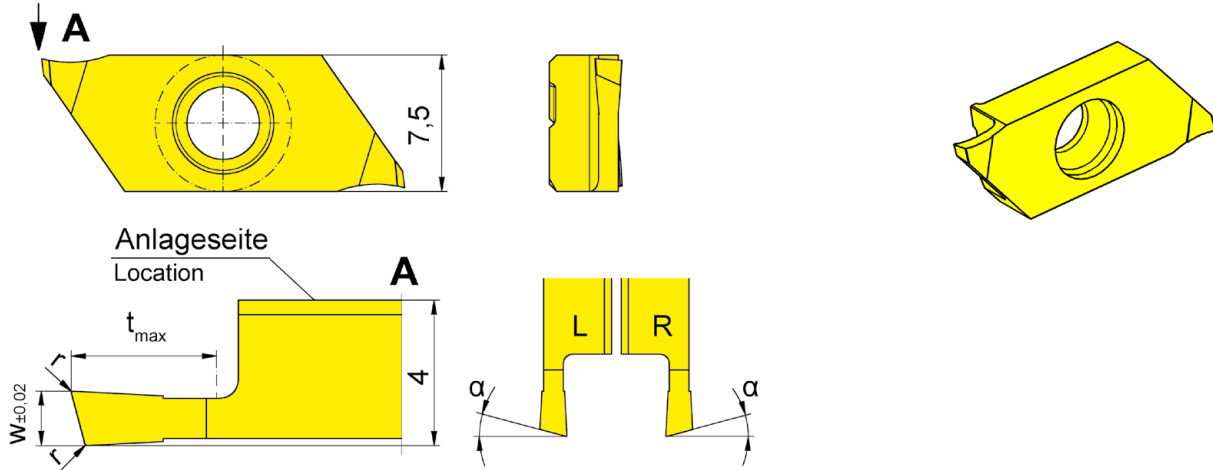
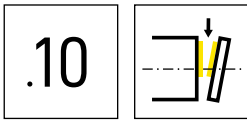

R = rechts wie gezeichnet
R = right hand version shown

L = links spiegelbildlich
L = left hand version

▲ ab Lager
on stock

HM-Sorten
Carbide grades
Δ 4 Wochen
4 weeks

Bestellnummer Part number	w	r	t _{max}	α	HIS	IG35	TH35
RS274.1508.03.10	0,8	0,05	3	15°	274040R	▲	▲
RS274.1510.03.10	1	0,05	3	15°	274040R	▲	▲
RS274.1515.04.10	1,5	0,05	4	15°	274040R	▲	▲
RS274.1520.06.10	2	0,05	6	15°	274040R	▲	▲
LS274.1508.03.10	0,8	0,05	3	15°	274040L	▲	▲
LS274.1510.03.10	1	0,05	3	15°	274040L	▲	▲
LS274.1515.04.10	1,5	0,05	4	15°	274040L	▲	▲
LS274.1520.06.10	2	0,05	6	15°	274040L	▲	▲

t_{max} 6 mm nur bei Werkstück-Ø ≤ 25 mm erreichbar.
t_{max} 6 mm can be reached only with workpiece Ø ≤ 25 mm.

P	-	●
M	●	●
K	-	●
N	-	●
S	●	●
H	-	-

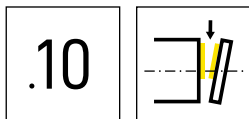

↓ A

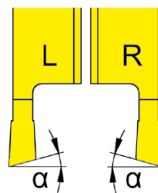
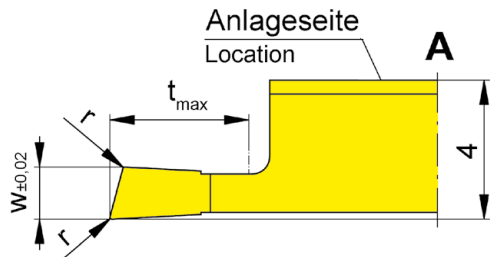
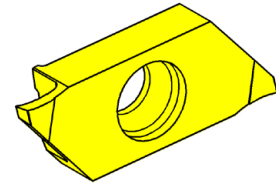
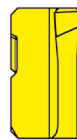
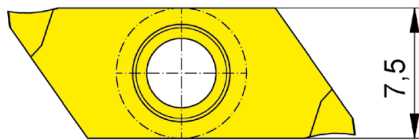

R = rechts wie gezeichnet
R = right hand version shown

L = links spiegelbildlich
L = left hand version

▲ ab Lager
on stock

HM-Sorten
Carbide grades
Δ 4 Wochen
4 weeks

Bestellnummer Part number	w	r	t _{max}	α	HIS	IG35	TH35
RS274.1508.03.10L	0,8	0,05	3	15°	274040R	Δ	Δ
RS274.1510.03.10L	1	0,05	3	15°	274040R	Δ	Δ
RS274.1515.04.10L	1,5	0,05	4	15°	274040R	Δ	Δ
RS274.1520.06.10L	2	0,05	6	15°	274040R	Δ	▲
LS274.1508.03.10R	0,8	0,05	3	15°	274040L	▲	▲
LS274.1510.03.10R	1	0,05	3	15°	274040L	▲	▲
LS274.1515.04.10R	1,5	0,05	4	15°	274040L	▲	▲
LS274.1520.06.10R	2	0,05	6	15°	274040L	▲	▲

t_{max} 6 mm nur bei Werkstück-Ø ≤ 25 mm erreichbar.
t_{max} 6 mm can be reached only with workpiece Ø ≤ 25 mm.

P	-	●
M	●	●
K	-	●
N	-	●
S	●	●
H	-	-

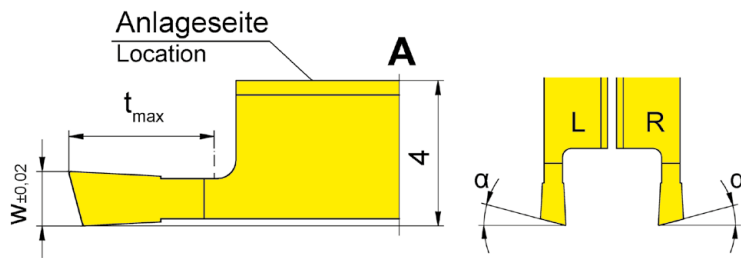
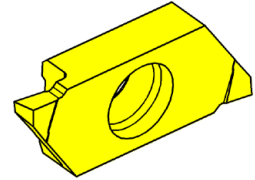
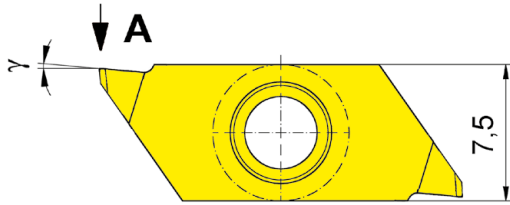
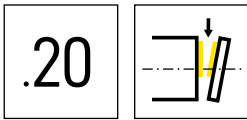

R = rechts wie gezeichnet
R = right hand version shown

L = links spiegelbildlich
L = left hand version

▲ ab Lager
on stock

HM-Sorten
Carbide grades
Δ 4 Wochen
4 weeks

Bestellnummer Part number	w	t_{max}	α	γ	HIS	IG35	TH35
RS274.1515.04.20	1,5	4	15°	5°	274040R	Δ	Δ
RS274.1520.06.20	2	6	15°	5°	274040R	Δ	Δ
LS274.1515.04.20	1,5	4	15°	5°	274040L	Δ	Δ
LS274.1520.06.20	2	6	15°	5°	274040L	Δ	Δ

t_{max} 6 mm nur bei Werkstück- $\varnothing \leq 25$ mm erreichbar.
 t_{max} 6 mm can be reached only with workpiece $\varnothing \leq 25$ mm.

P	-	●
M	●	●
K	-	●
N	-	●
S	●	●
H	-	-

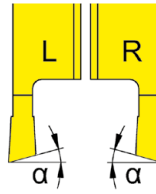
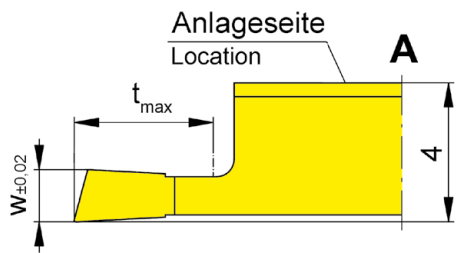
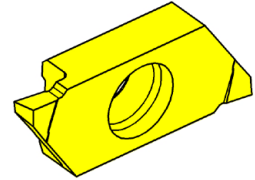
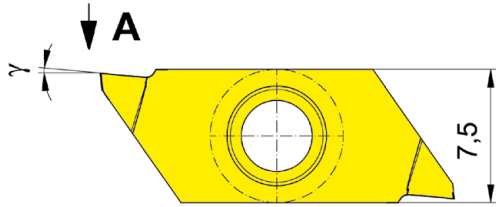
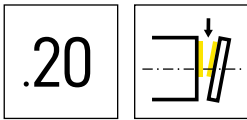

R = rechts wie gezeichnet
R = right hand version shown

L = links spiegelbildlich
L = left hand version

▲ ab Lager
on stock

HM-Sorten
Carbide grades
Δ 4 Wochen
4 weeks

Bestellnummer Part number	w	t _{max}	α	γ	HIS	IG35	TH35
RS274.1520.06.20L	2	6	15°	5°	274040R	Δ	Δ
LS274.1515.04.20R	1,5	4	15°	5°	274040L	Δ	Δ
LS274.1520.06.20R	2	6	15°	5°	274040L	Δ	Δ

t_{max} 6 mm nur bei Werkstück-Ø ≤ 25 mm erreichbar.
t_{max} 6 mm can be reached only with workpiece Ø ≤ 25 mm.

P	-	●
M	●	●
K	-	●
N	-	●
S	●	●
H	-	-

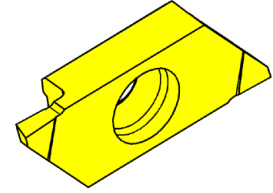
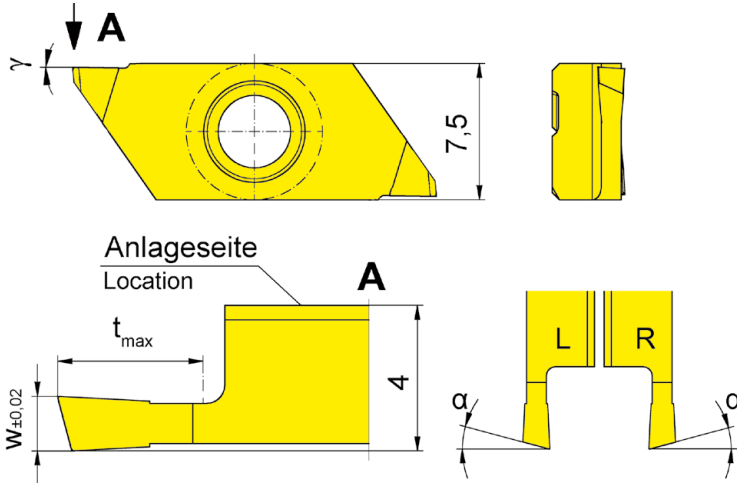
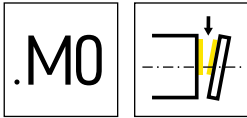

R = rechts wie gezeichnet
R = right hand version shown

L = links spiegelbildlich
L = left hand version

▲ ab Lager
on stock

HM-Sorten
Carbide grades
Δ 4 Wochen
4 weeks

Bestellnummer Part number	w	t _{max}	α	γ	HIS	IG35	TH35
RS274.1508.03.M0	0,8	3	15°	0°	274040R	Δ	Δ
RS274.1510.03.M0	1	3	15°	0°	274040R	Δ	▲
RS274.1515.04.M0	1,5	4	15°	0°	274040R	Δ	Δ
RS274.1520.06.M0	2	6	15°	0°	274040R	Δ	Δ
LS274.1508.03.M0	0,8	3	15°	0°	274040L	Δ	Δ
LS274.1510.03.M0	1	3	15°	0°	274040L	Δ	Δ
LS274.1515.04.M0	1,5	4	15°	0°	274040L	Δ	Δ
LS274.1520.06.M0	2	6	15°	0°	274040L	Δ	Δ

t_{max} 6 mm nur bei Werkstück-Ø ≤ 25 mm erreichbar.
t_{max} 6 mm can be reached only with workpiece Ø ≤ 25 mm.

P	-	●
M	●	●
K	-	●
N	-	●
S	●	●
H	-	-

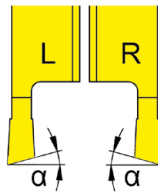
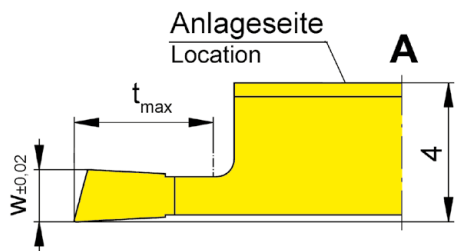
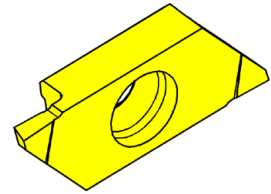
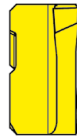
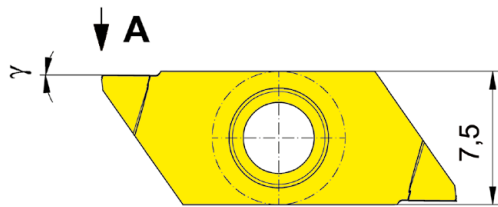
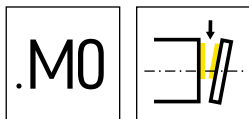

R = rechts wie gezeichnet
R = right hand version shown

L = links spiegelbildlich
L = left hand version

▲ ab Lager
on stock

HM-Sorten
Carbide grades
Δ 4 Wochen
4 weeks

Bestellnummer Part number	w	t _{max}	α	γ	HIS	IG35	TH35
RS274.1510.03.M0L	1	3	15°	0°	274040R	Δ	
RS274.1515.04.M0L	1,5	4	15°	0°	274040R	Δ	Δ
RS274.1520.06.M0L	2	6	15°	0°	274040R	Δ	Δ
LS274.1508.03.M0R	0,8	3	15°	0°	274040L	Δ	▲
LS274.1510.03.M0R	1	3	15°	0°	274040L	Δ	Δ
LS274.1515.04.M0R	1,5	4	15°	0°	274040L	Δ	Δ
LS274.1520.06.M0R	2	6	15°	0°	274040L	Δ	Δ

t_{max} 6 mm nur bei Werkstück-Ø ≤ 25 mm erreichbar.
t_{max} 6 mm can be reached only with workpiece Ø ≤ 25 mm.

P	-	●
M	●	●
K	-	●
N	-	●
S	●	●
H	-	-

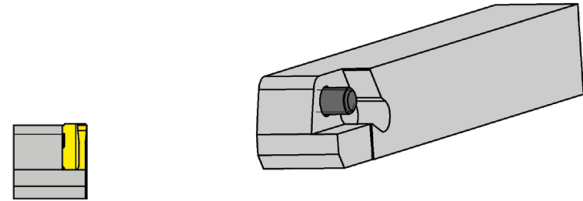
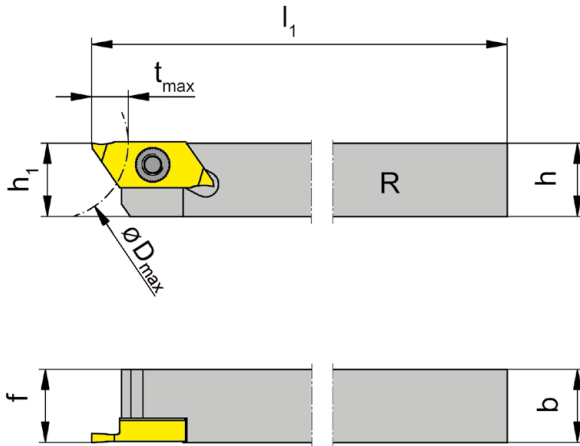
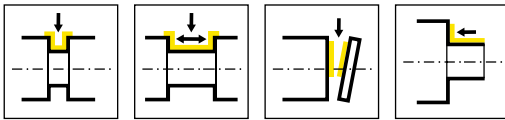

R = rechts wie gezeichnet
R = right hand version shown

L = links spiegelbildlich
L = left hand version

Bestellnummer Part number	h	b	l ₁	h ₁	f	t _{max}	D _{max}	HWS
RH274.0808.04.E	8	8	100	8	8	6	25	274140R
RH274.1010.04.E	10	10	100	10	10	6	25	274140R
RH274.1212.04.E	12	12	100	12	12	6	25	274140R
RH274.1616.04.E	16	16	125	16	16	6	25	274140R
RH274.2020.04.E	20	20	125	20	20	6	25	274140R
LH274.0808.04.E	8	8	100	8	8	6	25	274140L
LH274.1010.04.E	10	10	100	10	10	6	25	274140L
LH274.1212.04.E	12	12	100	12	12	6	25	274140L
LH274.1616.04.E	16	16	125	16	16	6	25	274140L
LH274.2020.04.E	20	20	125	20	20	6	25	274140L

Ersatzteile
Spare Parts

Klemmhalter Toolholder	TORX PLUS®-Schlüssel TORX PLUS® Wrench	Spannschraube Clamping Screw
R/LH274.0808.04.E	T15PQ	
R/LH274...	T15PQ	030.3509.T15P

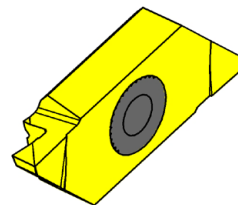
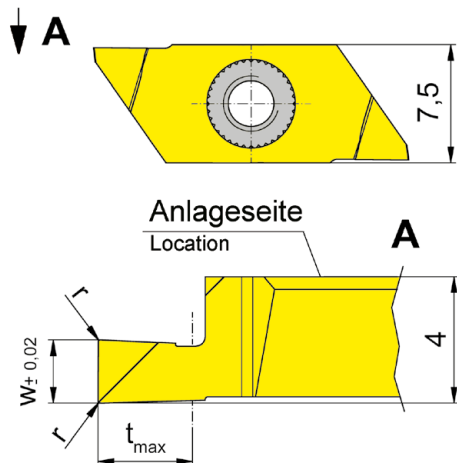
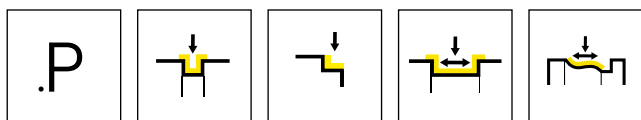

R = rechts wie gezeichnet
R = right hand version shown

L = links spiegelbildlich
L = left hand version

▲ ab Lager
on stock

HM-Sorten
Carbide grades
Δ 4 Wochen
4 weeks

Bestellnummer Part number	w	r	t _{max}	HIS	IG35	TH35
RS274.0150.P0.E	1,5	0,05	2,25	274140R	Δ	Δ
RS274.0200.P0.E	2	0,05	3	274140R	Δ	Δ
RS274.0250.P0.E	2,5	0,1	3,75	274140R	Δ	Δ
RS274.0300.P0.E	3	0,1	4,5	274140R	Δ	Δ
LS274.0150.P0.E	1,5	0,05	2,25	274140L	Δ	Δ
LS274.0200.P0.E	2	0,05	3	274140L	Δ	Δ
LS274.0250.P0.E	2,5	0,1	3,75	274140L	Δ	Δ
LS274.0300.P0.E	3	0,1	4,5	274140L	Δ	Δ
					P	- ●
					M	● ●
					K	- ●
					N	- ●
					S	● ●
					H	- -

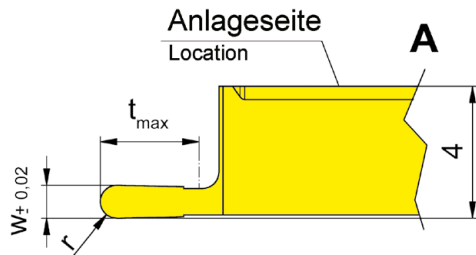
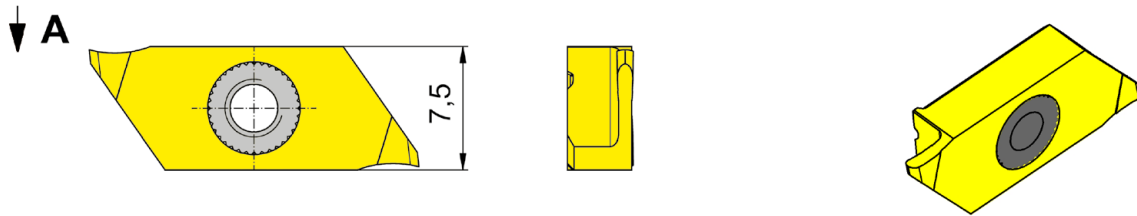
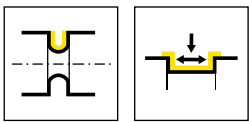

R = rechts wie gezeichnet
R = right hand version shown

L = links spiegelbildlich
L = left hand version

▲ ab Lager
on stock

HM-Sorten
Carbide grades
Δ 4 Wochen
4 weeks

Bestellnummer Part number	w	t _{max}	r	HIS	IG35	TH35
RS274.0205.01.10.E	0,5	1,5	0,25	274140R	Δ	Δ
RS274.0510.03.10.E	1	3	0,5	274140R	Δ	▲
RS274.1020.04.10.E	2	4	1	274140R	Δ	Δ
LS274.0205.01.10.E	0,5	1,5	0,25	274140L	Δ	Δ
LS274.0510.03.10.E	1	3	0,5	274140L	Δ	Δ
LS274.1020.04.10.E	2	4	1	274140L	Δ	Δ
					P	- ●
					M	● ●
					K	- ●
					N	- ●
					S	● ●
					H	- -

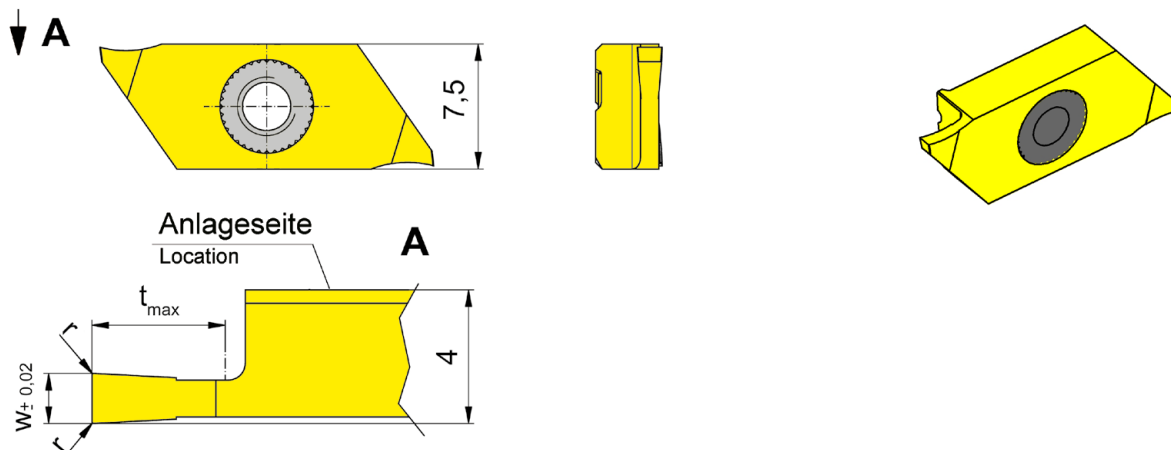
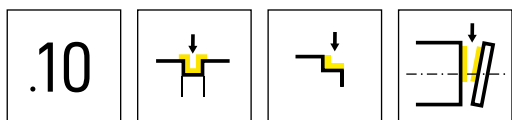

R = rechts wie gezeichnet
R = right hand version shown

L = links spiegelbildlich
L = left hand version

▲ ab Lager
on stock

HM-Sorten
Carbide grades
Δ 4 Wochen
4 weeks

Bestellnummer Part number	w	r	t _{max}	HIS	IG35	TH35
RS274.0120.03.10.E	1,2	0,05	3	274140R	Δ	Δ
RS274.0050.01.10.E	0,5	0,05	1,5	274140R	Δ	Δ
RS274.0070.02.10.E	0,7	0,05	2	274140R	Δ	Δ
RS274.0080.03.10.E	0,8	0,05	3	274140R	Δ	Δ
RS274.0100.03.10.E	1	0,05	3	274140R	Δ	Δ
RS274.0150.04.10.E	1,5	0,05	4	274140R	Δ	Δ
RS274.0150.06.10.E	1,5	0,05	6	274140R	Δ	Δ
RS274.0200.04.10.E	2	0,05	4	274140R	Δ	Δ
RS274.0200.06.10.E	2	0,05	6	274140R	Δ	Δ
LS274.0120.03.10.E	1,2	0,05	3	274140L	Δ	Δ
LS274.0050.01.10.E	0,5	0,05	1,5	274140L	Δ	Δ
LS274.0070.02.10.E	0,7	0,05	2	274140L	Δ	Δ
LS274.0080.03.10.E	0,8	0,05	3	274140L	Δ	Δ
LS274.0100.03.10.E	1	0,05	3	274140L	Δ	Δ
LS274.0150.04.10.E	1,5	0,05	4	274140L	Δ	Δ
LS274.0150.06.10.E	1,5	0,05	6	274140L	Δ	Δ
LS274.0200.04.10.E	2	0,05	4	274140L	Δ	Δ
LS274.0200.06.10.E	2	0,05	6	274140L	Δ	Δ

P	-	●
M	●	●
K	-	●
N	-	●
S	●	●
H	-	-

Wendeschneidplatte

Indexable insert

S274...E

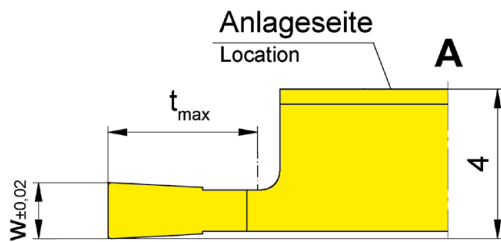
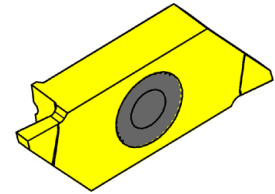
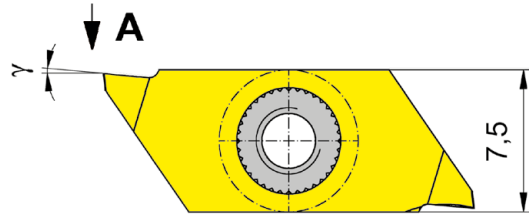
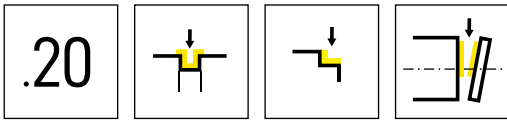

R = rechts wie gezeichnet
R = right hand version shown

L = links spiegelbildlich
L = left hand version

▲ ab Lager
on stock

HM-Sorten
Carbide grades
Δ 4 Wochen
4 weeks

Bestellnummer Part number	w	t _{max}	γ	HIS	IG35	TH35
RS274.0050.01.20.E	0,5	1,5	5°	274140R	Δ	Δ
RS274.0070.02.20.E	0,7	2	5°	274140R	Δ	Δ
RS274.0080.03.20.E	0,8	3	5°	274140R	Δ	Δ
RS274.0100.03.20.E	1	3	5°	274140R	Δ	Δ
RS274.0120.03.20.E	1,2	3	5°	274140R	Δ	Δ
RS274.0150.06.20.E	1,5	6	5°	274140R	Δ	Δ
RS274.0200.04.20.E	2	4	5°	274140R	Δ	Δ
RS274.0200.06.20.E	2	6	5°	274140R	Δ	Δ
LS274.0050.01.20.E	0,5	1,5	5°	274140L	Δ	Δ
LS274.0070.02.20.E	0,7	2	5°	274140L	Δ	Δ
LS274.0080.03.20.E	0,8	3	5°	274140L	Δ	Δ
LS274.0100.03.20.E	1	3	5°	274140L	Δ	Δ
LS274.0120.03.20.E	1,2	3	5°	274140L	Δ	Δ
LS274.0150.06.20.E	1,5	6	5°	274140L	Δ	Δ
LS274.0200.04.20.E	2	4	5°	274140L	Δ	Δ
LS274.0200.06.20.E	2	6	5°	274140L	Δ	Δ
P	-	●				
M	●	●				
K	-	●				
N	-	●				
S	●	●				
H	-	-				



Wendeschneidplatte

Indexable insert

S274...E

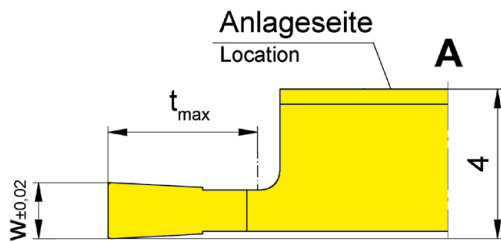
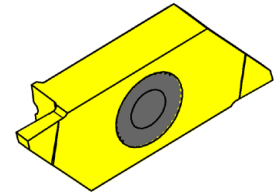
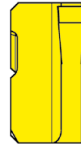
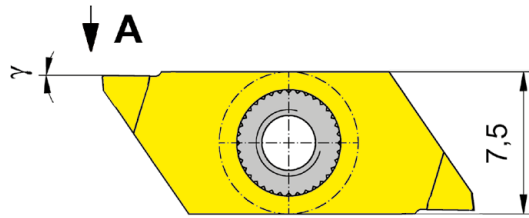
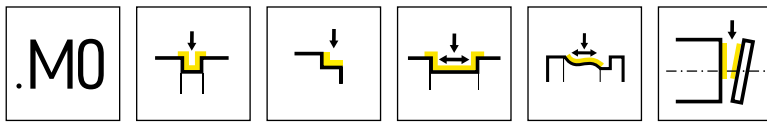

R = rechts wie gezeichnet
R = right hand version shown

L = links spiegelbildlich
L = left hand version

▲ ab Lager
on stock

HM-Sorten
Carbide grades
Δ 4 Wochen
4 weeks

Bestellnummer Part number	w	t_{max}	γ	HIS	IG35	TH35
RS274.0050.01.M0.E	0,5	1,5	0°	274140R	Δ	Δ
RS274.0070.02.M0.E	0,7	2	0°	274140R	Δ	Δ
RS274.0080.03.M0.E	0,8	3	0°	274140R	Δ	Δ
RS274.0100.03.M0.E	1	3	0°	274140R	Δ	Δ
RS274.0120.03.M0.E	1,2	3	0°	274140R	Δ	Δ
RS274.0150.04.M0.E	1,5	4	0°	274140R	Δ	Δ
RS274.0150.06.M0.E	1,5	6	0°	274140R	Δ	Δ
RS274.0200.04.M0.E	2	4	0°	274140R	Δ	Δ
RS274.0200.06.M0.E	2	6	0°	274140R	Δ	Δ
LS274.0050.01.M0.E	0,5	1,5	0°	274140L	Δ	Δ
LS274.0070.02.M0.E	0,7	2	0°	274140L	Δ	Δ
LS274.0080.03.M0.E	0,8	3	0°	274140L	Δ	Δ
LS274.0100.03.M0.E	1	3	0°	274140L	Δ	Δ
LS274.0120.03.M0.E	1,2	3	0°	274140L	Δ	Δ
LS274.0150.04.M0.E	1,5	4	0°	274140L	Δ	Δ
LS274.0150.06.M0.E	1,5	6	0°	274140L	Δ	Δ
LS274.0200.04.M0.E	2	4	0°	274140L	Δ	Δ
LS274.0200.06.M0.E	2	6	0°	274140L	Δ	Δ

P	-	●
M	●	●
K	-	●
N	-	●
S	●	●
H	-	-

J

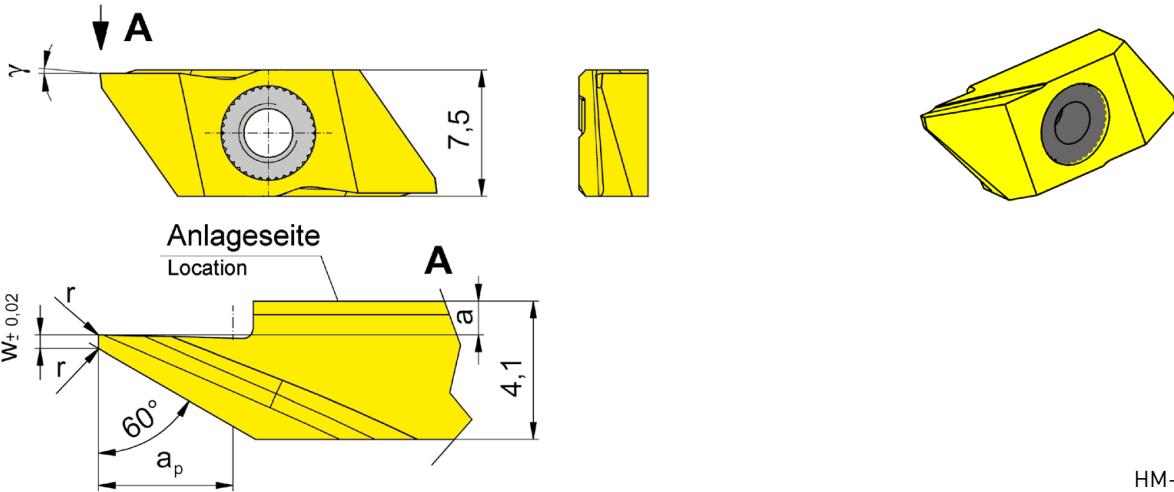
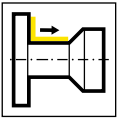

R = rechts wie gezeichnet
R = right hand version shown

L = links spiegelbildlich
L = left hand version

▲ ab Lager
on stock

HM-Sorten
Carbide grades
Δ 4 Wochen
4 weeks

Bestellnummer Part number	w	r	a	γ	a _p	HIS		K10	IG35	TH35
RS274.0060.04.10.E	-	0,05	1	15°	4	274140R			Δ	Δ
RS274.0460.04.10.E	0,4	0,05	1	15°	4	274140R			Δ	▲
RS274.0460.04.M0.E	0,4	0,05	1	0°	4	274140R		Δ	Δ	Δ
RS274.0560.06.11.E	0,5	0,1	0,05	15°	6	274140R			Δ	▲
LS274.0060.04.10.E	-	0,05	1	15°	4	274140L			Δ	Δ
LS274.0460.04.10.E	0,4	0,05	1	15°	4	274140L			Δ	Δ
LS274.0460.04.M0.E	0,4	0,05	1	0°	4	274140L		Δ	Δ	Δ
LS274.0560.06.11.E	0,5	0,1	0,05	15°	6	274140L			Δ	Δ
							P	●	-	●
							M	○	●	●
							K	●	-	●
							N	●	-	●
							S	○	●	●
							H	-	-	-

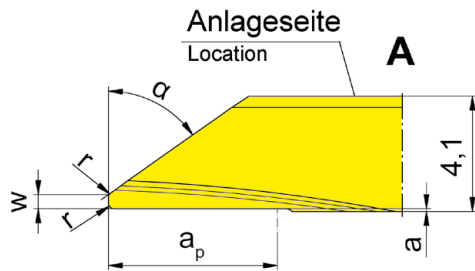
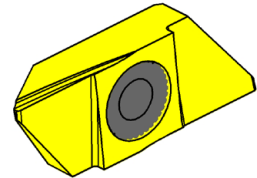
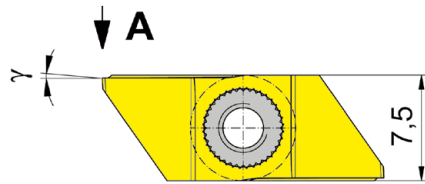
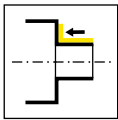

R = rechts wie gezeichnet
R = right hand version shown

L = links spiegelbildlich
L = left hand version

▲ ab Lager
on stock

HM-Sorten
Carbide grades
Δ 4 Wochen
4 weeks

Bestellnummer Part number	w	r	a	γ	a_p	α	HIS	IG35	TH35
RS274.0035.04.20.E	-	0,05	0,1	5°	4	35°	274140R	Δ	Δ
RS274.0235.04.20.E	0,2	-	0,1	5°	4	35°	274140R	Δ	Δ
RS274.0535.06.20.E	0,5	0,2	0,1	5°	6	35°	274140R	Δ	Δ
RS274.0055.04.20.E	-	0,05	0,1	5°	4	55°	274140R	Δ	Δ
RS274.0255.04.20.E	0,2	-	0,1	5°	4	55°	274140R	Δ	Δ
RS274.0555.06.20.E	0,5	0,2	0,1	5°	6	55°	274140R	Δ	Δ
LS274.0035.04.20.E	-	0,05	0,1	5°	4	35°	274140L	Δ	Δ
LS274.0235.04.20.E	0,2	-	0,1	5°	4	35°	274140L	Δ	Δ
LS274.0535.06.20.E	0,5	0,2	0,1	5°	6	35°	274140L	Δ	Δ
LS274.0055.04.20.E	-	0,05	0,1	5°	4	55°	274140L	Δ	Δ
LS274.0255.04.20.E	0,2	-	0,1	5°	4	55°	274140L	Δ	Δ
LS274.0555.06.20.E	0,5	0,2	0,1	5°	6	55°	274140L	Δ	Δ
P	-	•							
M	•	•							
K	-	•							
N	-	•							
S	•	•							
H	-	-							

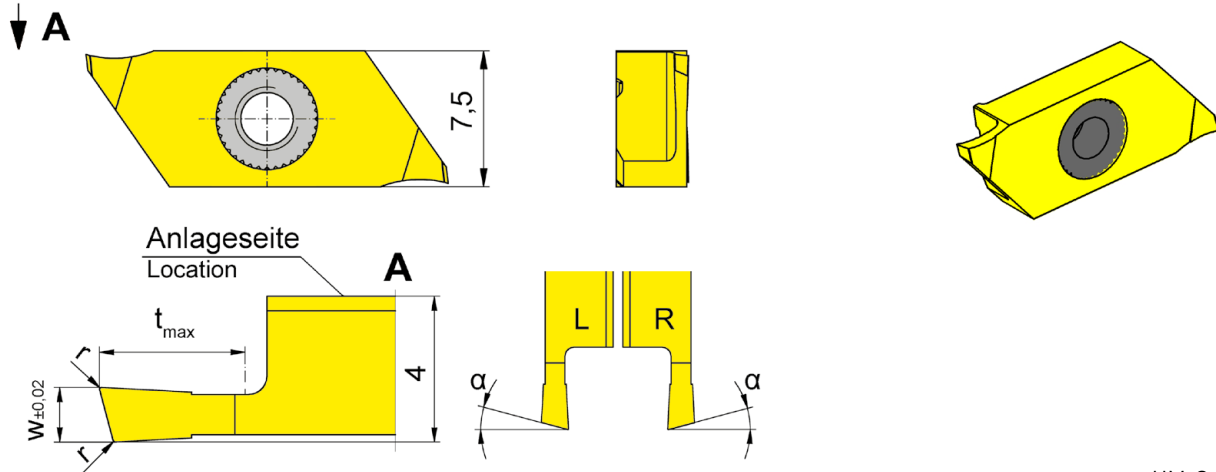
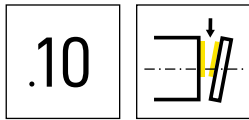

R = rechts wie gezeichnet
R = right hand version shown

L = links spiegelbildlich
L = left hand version

▲ ab Lager
on stock

HM-Sorten
Carbide grades
Δ 4 Wochen
4 weeks

Bestellnummer Part number	w	r	t _{max}	α	HIS	IG35	TH35
RS274.1508.03.10.E	0,8	0,05	3	15°	274140R	Δ	Δ
RS274.1510.03.10.E	1	0,05	3	15°	274140R	Δ	Δ
RS274.1515.04.10.E	1,5	0,05	4	15°	274140R	Δ	Δ
RS274.1520.06.10.E	2	0,05	6	15°	274140R	Δ	Δ
LS274.1508.03.10.E	0,8	0,05	3	15°	274140L	Δ	Δ
LS274.1510.03.10.E	1	0,05	3	15°	274140L	Δ	Δ
LS274.1515.04.10.E	1,5	0,05	4	15°	274140L	Δ	Δ
LS274.1520.06.10.E	2	0,05	6	15°	274140L	Δ	Δ

t_{max} 6 mm nur bei Werkstück-Ø ≤ 25 mm erreichbar.
t_{max} 6 mm can be reached only with workpiece Ø ≤ 25 mm.

P	-	●
M	●	●
K	-	●
N	-	●
S	●	●
H	-	-

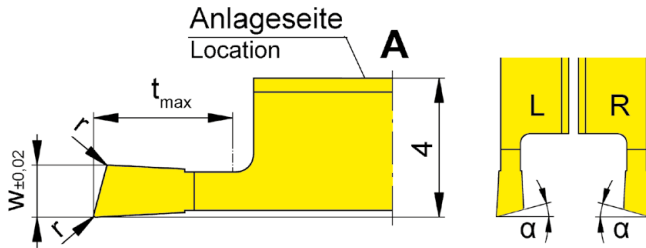
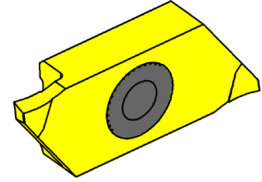
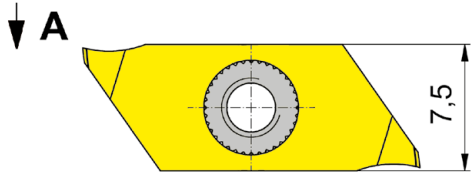
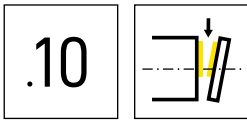

R = rechts wie gezeichnet
R = right hand version shown

L = links spiegelbildlich
L = left hand version

▲ ab Lager
on stock

HM-Sorten
Carbide grades
Δ 4 Wochen
4 weeks

Bestellnummer Part number	w	r	t _{max}	α	HIS	IG35	TH35
RS274.1508.03.1L.E	0,8	0,05	3	15°	274140R	Δ	Δ
RS274.1510.03.1L.E	1	0,05	3	15°	274140R	Δ	Δ
RS274.1515.04.1L.E	1,5	0,05	4	15°	274140R	Δ	Δ
RS274.1520.06.1L.E	2	0,05	6	15°	274140R	Δ	Δ
LS274.1508.03.1R.E	0,8	0,05	3	15°	274140L	Δ	Δ
LS274.1510.03.1R.E	1	0,05	3	15°	274140L	Δ	Δ
LS274.1520.06.1R.E	2	0,05	6	15°	274140L	Δ	Δ

t_{max} 6 mm nur bei Werkstück-Ø ≤ 25 mm erreichbar.
t_{max} 6 mm can be reached only with workpiece Ø ≤ 25 mm.

P	-	●
M	●	●
K	-	●
N	-	●
S	●	●
H	-	-

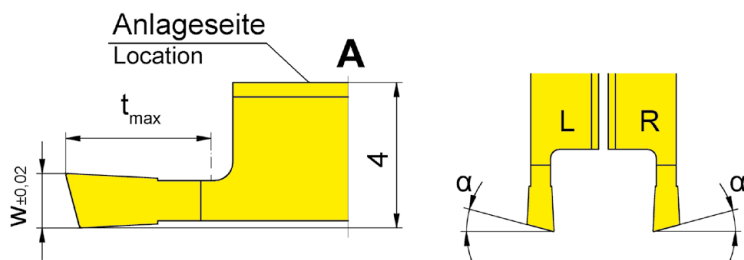
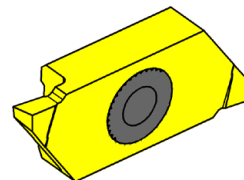
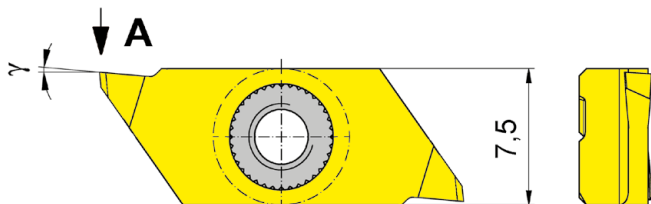

R = rechts wie gezeichnet
R = right hand version shown

L = links spiegelbildlich
L = left hand version

▲ ab Lager
on stock

HM-Sorten
Carbide grades
Δ 4 Wochen
4 weeks

Bestellnummer Part number	w	t _{max}	α	γ	HIS	IG35	TH35
RS274.1515.04.20.E	1,5	4	15°	5°	274140R	Δ	Δ
RS274.1520.06.20.E	2	6	15°	5°	274140R	Δ	Δ
LS274.1515.04.20.E	1,5	4	15°	5°	274140L	Δ	Δ
LS274.1520.06.20.E	2	6	15°	5°	274140L	Δ	Δ

t_{max} 6 mm nur bei Werkstück-Ø ≤ 25 mm erreichbar.
t_{max} 6 mm can be reached only with workpiece Ø ≤ 25 mm.

P	-	●
M	●	●
K	-	●
N	-	●
S	●	●
H	-	-



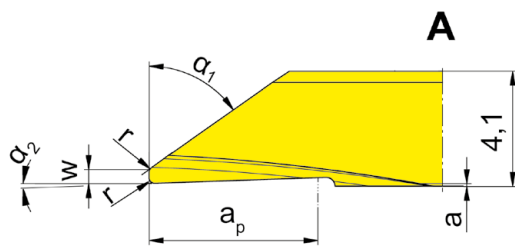
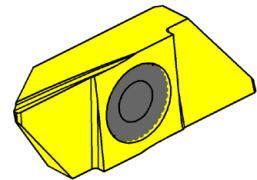
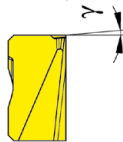
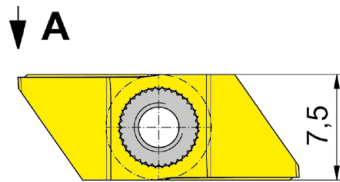
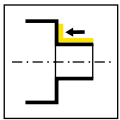

HM-Sorten
Carbide grades

▲ ab Lager
on stock

△ 4 Wochen
4 weeks

Bestellnummer Part number	w	r	a	γ	a _p	α ₂	IG35	TH35
RS274.0035.24.20.E	-	0,05	0,1	5°	4	2°	△	△
RS274.0055.24.20.E	-	0,05	0,1	5°	4	2°	△	△
RS274.0235.24.20.E	0,2	-	0,1	5°	4	2°	△	△
RS274.0255.24.20.E	0,2	-	0,1	5°	4	2°	△	△
LS274.0035.24.20.E	-	0,05	0,1	5°	4	2°	△	△
LS274.0055.24.20.E	-	0,05	0,1	5°	4	2°	△	△
LS274.0235.24.20.E	0,2	-	0,1	5°	4	2°	△	△
LS274.0255.24.20.E	0,2	-	0,1	5°	4	2°	△	△
LS274.0535.26.20.E	0,5	0,2	0,1	5°	6	2°	△	△
LS274.0555.26.20.E	0,5	0,2	0,1	5°	6	2°	△	△
	P	-	●					
	M	●	●					
	K	-	●					
	N	-	●					
	S	●	●					
	H	-	-					

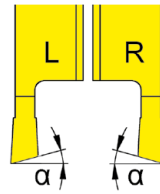
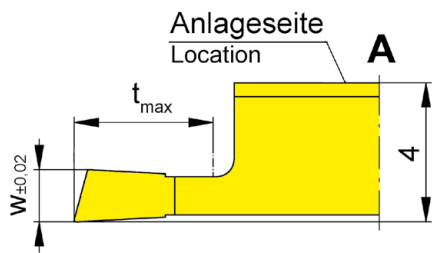
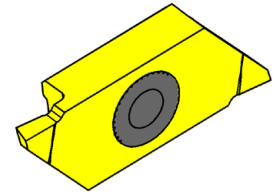
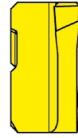
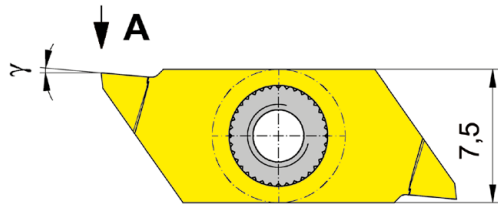
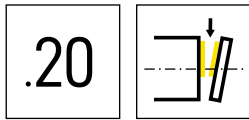

R = rechts wie gezeichnet
R = right hand version shown

L = links spiegelbildlich
L = left hand version

▲ ab Lager
on stock

HM-Sorten
Carbide grades
Δ 4 Wochen
4 weeks

Bestellnummer Part number	w	t _{max}	α	γ	HIS	IG35	TH35
RS274.1515.04.2L.E	1,5	4	15°	5°	274140R	Δ	Δ
RS274.1520.06.2L.E	2	6	15°	5°	274140R	Δ	Δ
LS274.1515.04.2R.E	1,5	4	15°	5°	274140L	Δ	Δ
LS274.1520.06.2R.E	2	6	15°	5°	274140L	Δ	Δ

t_{max} 6 mm nur bei Werkstück-Ø ≤ 25 mm erreichbar.
t_{max} 6 mm can be reached only with workpiece Ø ≤ 25 mm.

P	-	●
M	●	●
K	-	●
N	-	●
S	●	●
H	-	-

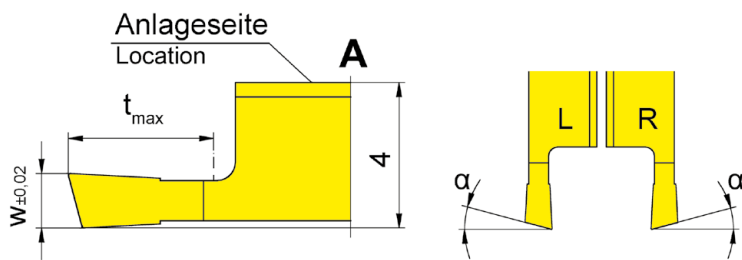
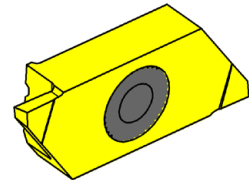
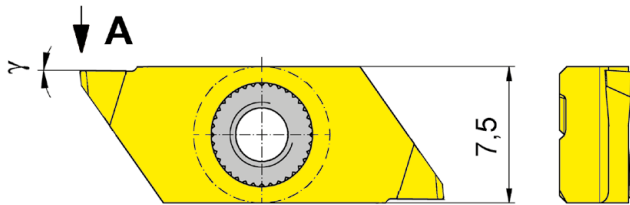
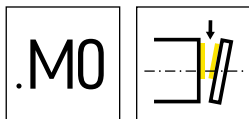

R = rechts wie gezeichnet
R = right hand version shown

L = links spiegelbildlich
L = left hand version

▲ ab Lager
on stock

HM-Sorten
Carbide grades
Δ 4 Wochen
4 weeks

Bestellnummer Part number	w	t _{max}	α	γ	HIS	IG35	TH35
RS274.1508.03.M0.E	0,8	3	15°	0°	274140R	Δ	Δ
RS274.1510.03.M0.E	1	3	15°	0°	274140R	Δ	Δ
RS274.1515.04.M0.E	1,5	4	15°	0°	274140R	Δ	Δ
RS274.1520.06.M0.E	2	6	15°	0°	274140R	Δ	Δ
LS274.1508.03.M0.E	0,8	3	15°	0°	274140L	Δ	Δ
LS274.1510.03.M0.E	1	3	15°	0°	274140L	Δ	Δ
LS274.1515.04.M0.E	1,5	4	15°	0°	274140L	Δ	Δ
LS274.1520.06.M0.E	2	6	15°	0°	274140L	Δ	Δ

t_{max} 6 mm nur bei Werkstück-Ø ≤ 25 mm erreichbar.
t_{max} 6 mm can be reached only with workpiece Ø ≤ 25 mm.

P	-	●
M	●	●
K	-	●
N	-	●
S	●	●
H	-	-

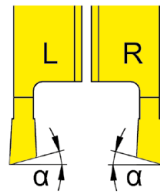
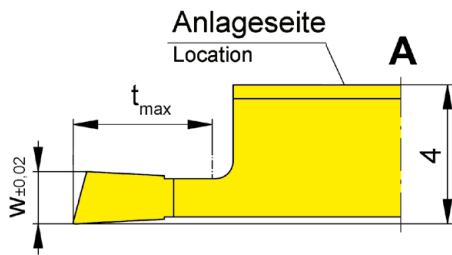
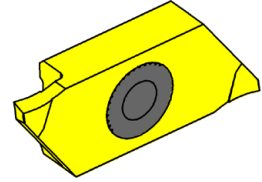
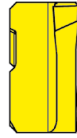
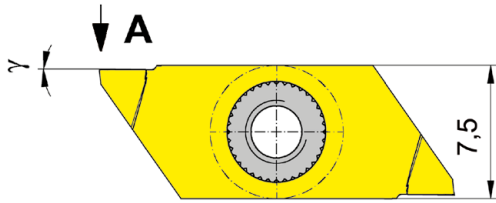
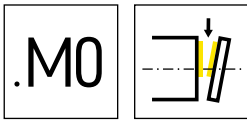

R = rechts wie gezeichnet
R = right hand version shown

L = links spiegelbildlich
L = left hand version

▲ ab Lager
on stock

HM-Sorten
Carbide grades
Δ 4 Wochen
4 weeks

Bestellnummer Part number	w	t _{max}	α	γ	HIS	HM-Sorten	
						IG35	TH35
RS274.1508.03.ML.E	0,8	3	15°	0°	274140R		Δ
RS274.1510.03.ML.E	1	3	15°	0°	274140R		Δ
RS274.1515.04.ML.E	1,5	4	15°	0°	274140R		Δ
RS274.1520.06.ML.E	2	6	15°	0°	274140R		Δ
LS274.1508.03.MR.E	0,8	3	15°	0°	274140L	Δ	
LS274.1510.03.MR.E	1	3	15°	0°	274140L	Δ	Δ
LS274.1515.04.MR.E	1,5	4	15°	0°	274140L		Δ
LS274.1520.06.MR.E	2	6	15°	0°	274140L	Δ	Δ

t_{max} 6 mm nur bei Werkstück-Ø ≤ 25 mm erreichbar.
t_{max} 6 mm can be reached only with workpiece Ø ≤ 25 mm.

P	-	●
M	●	●
K	-	●
N	-	●
S	●	●
H	-	-

274

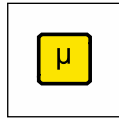

μ-Finish

ist der Begriff für eine besonders hohe Qualitätsstufe der Schneide. Die gebräuchlichsten Schneidplatten zum Drehen, Einstechen Rückwärtsdrehen und (Ab-)Stechen in der Mikro-Drehbearbeitung der Uhrenindustrie sind als Standard zur Feinstbearbeitung lieferbar. Die Geometrien sind für die Bearbeitung von Stählen wie 20AP, rostfreien Stählen wie 4C27A und Messing der Uhrenindustrie optimiert. In Kombination mit dem Hartmetall und einer neu entwickelten Beschichtung sind Ihnen höchste Standmengen sicher und Sie steigern unweigerlich Ihre Produktivität.

is the term used to describe a particularly high quality of cutting edge. The most frequently used inserts for turning, backturning, grooving and parting off in the micro-turning processes involved in the watch-making industry are available for ultrafine machining. The geometries are optimized for machining steels such as 20AP, stainless steels such as 4C27A and brass used in the watch-making industry. Combination with the carbide and a newly developed coating guarantees maximum tool life quantities and will inevitably improve your productivity.

J

Einsatzgebiete

Applications

Material Material	ES15	ES1P	Bewertung Review
Stahl mit Blei Steel with lead		X	optimales Substrat, maßhaltige Fertigung, sehr gute Oberflächengüte ideal application material, good tool life, dimensional stable, very good surface qualities
Stahl ohne Blei Steel without lead		X	optimales Substrat, maßhaltige Fertigung, sehr gute Oberflächengüte ideal application material, good tool life, dimensional stable, very good surface qualities
Rostfreier Stahl Stainless steel	X		optimales Substrat, maßhaltige Fertigung, sehr gute Oberflächengüte ideal application material, good tool life, dimensional stable, very good surface qualities

μ-Finish - Vorteile im Überblick

μ-Finish - Benefits at a glance

- ✓ Feinstgeschliffene scharfe Schneiden
Exceptionally fine-ground sharp cutting edges
- ✓ Exakte Spitzenhöhe der Schneide +/-0,0025 mm
Exact centre height of the cutting edge +/-0.0025 mm
- ✓ Reduzierte Einricht- und Stillstandszeiten
Reduced set-up times and downtimes
- ✓ Neue Beschichtung ES1 / ES1P für höchste Standzeiten
New ES1 / ES1P coating for maximum durability
- ✓ Schneidplatten nach Kundenspezifikation herstellbar
Inserts can be manufactured according to customer specifications

Wendeschneidplatte

Schneidenkontur absolut ausbruchsfrei!

Indexable insert

cutting contour with absolutely no chipping!

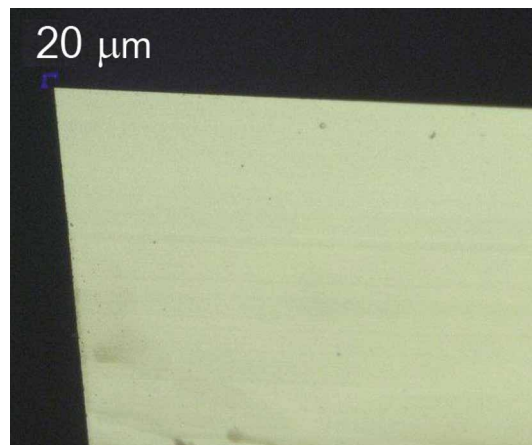

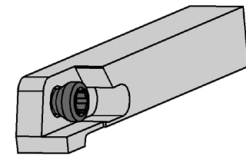
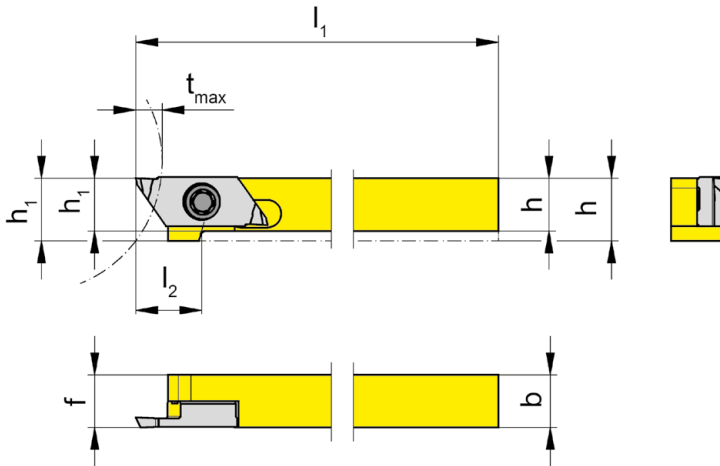
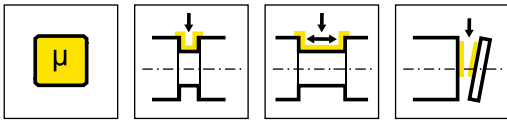

R = rechts wie gezeichnet
R = right hand version shown

L = links spiegelbildlich
L = left hand version

Bestellnummer Part number	h	b	l ₁	l ₂	h ₁	f	t _{max}	HWS
RH274.0808.SF.04	8	8	100	10	9,5	8	6	274040R
RH274.1010.SF.04	10	10	100	-	10	10	6	274040R
RH274.1212.SF.04	12	12	100	-	12	12	6	274040R

Bei Schaftabmessung 8 x 8 mm, Klemmhalter mit Absetzung am Kopf.
For shank dimension 8 x 8 mm toolholder with offset at the head.

Ersatzteile
Spare Parts

Klemmhalter Toolholder	Spannschraube Clamping Screw	TORX PLUS®-Schlüssel TORX PLUS® Wrench
RH274...	030.350P.0852	T15PQ

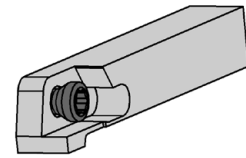
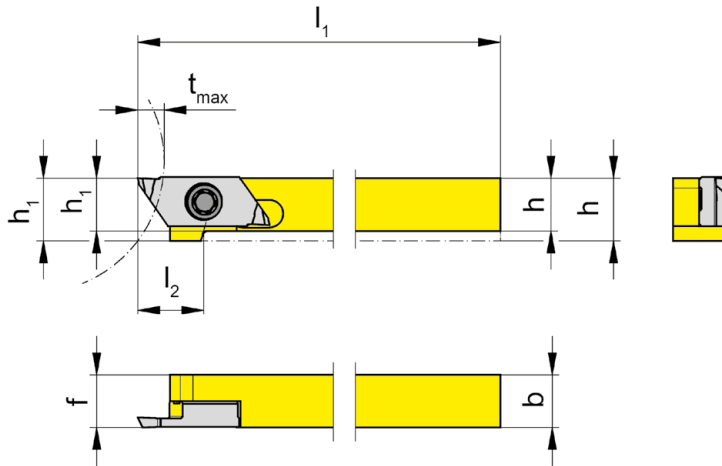
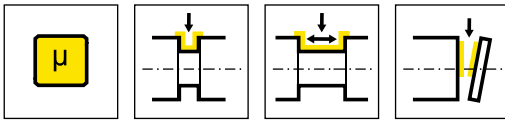

R = rechts wie gezeichnet
R = right hand version shown

L = links spiegelbildlich
L = left hand version

Bestellnummer Part number	h	b	l ₁	l ₂	h ₁	f	t _{max}	HWS
RH274.0808.SF.S4	8	8	100	10	9,5	8	6	274040R
RH274.1010.SF.S4	10	10	100	-	10	10	6	274040R
RH274.1212.SF.S4	12	12	100	-	12	12	6	274040R

Schaftmaterial: Schwermetall (schwingungsarm)
Material of shank: tungsten alloy (giving good vibration resistance)

Bei Schaftabmessung 8 x 8 mm, Klemmhalter mit Absetzung am Kopf.
For shank dimension 8 x 8 mm toolholder with offset at the head.

Ersatzteile
Spare Parts

Klemmhalter Toolholder	Spannschraube Clamping Screw	TORX PLUS®-Schlüssel TORX PLUS® Wrench
RH274...	030.350P.0852	T15PQ

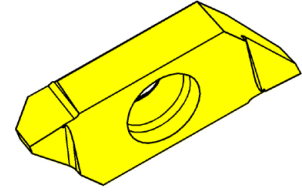
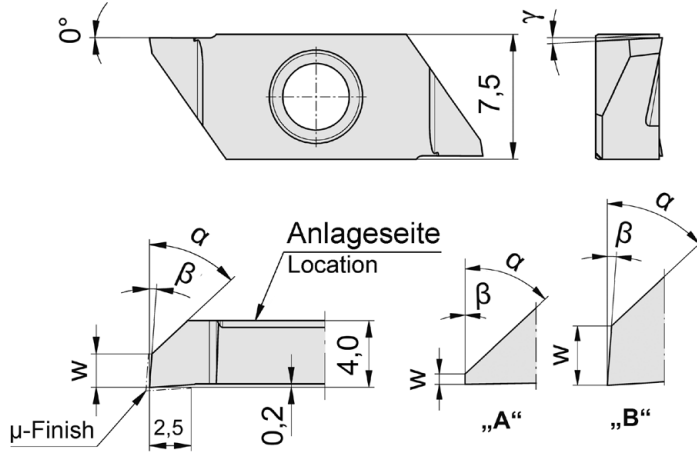
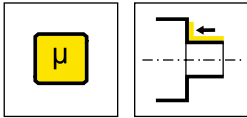

R = rechts wie gezeichnet
R = right hand version shown

L = links spiegelbildlich
L = left hand version

▲ ab Lager
on stock

HM-Sorten
Carbide grades
Δ 4 Wochen
4 weeks

Bestellnummer Part number	w	γ	α	Form	β	HIS	ES15	ES1P
RS274.0547.04.SF	0,05	0°	47°	A	0°	274040R	▲	Δ
RS274.2047.03.SF	0,05	0°	47°	A	0°	274040R	▲	Δ
LS274.2047.03.SF	0,05	0°	47°	A	0°	274040L	Δ	Δ
							P ●	●
							M ●	●
							K ○	○
							N -	-
							S -	-
							H -	-

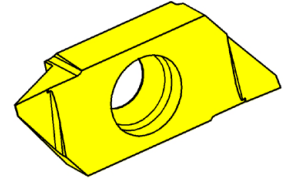
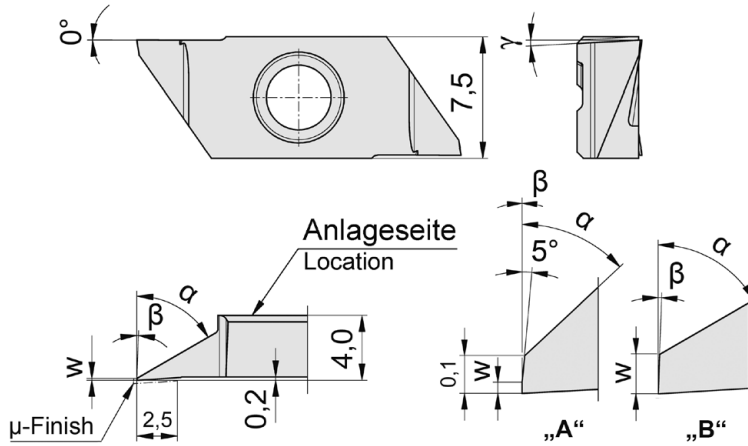
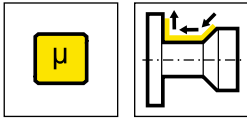

R = rechts wie gezeichnet
R = right hand version shown

L = links spiegelbildlich
L = left hand version

▲ ab Lager
on stock

HM-Sorten
Carbide grades
Δ 4 Wochen
4 weeks

Bestellnummer Part number	w	γ	α	Form	β	HIS	MG12	ES15	ES1P
RS274.0147.04.SF	0,03	0°	47°	A	0°	274040R		Δ	Δ
RS274.0160.03.SF	0,105	3°	60°	B	2°	274040R	Δ	Δ	Δ
LS274.0160.03.SF	0,105	3°	60°	B	2°	274040L		Δ	Δ
							P	o	•
							M	-	•
							K	-	o
							N	-	-
							S	-	-
							H	-	-

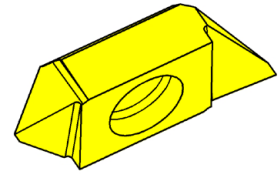
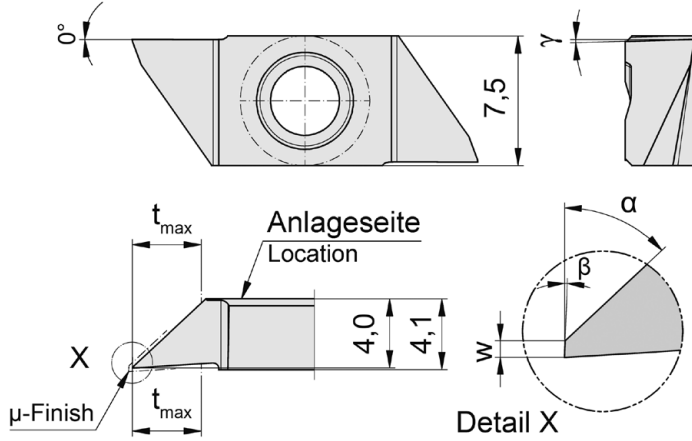
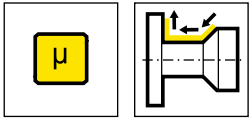

R = rechts wie gezeichnet
R = right hand version shown

▲ ab Lager
on stock

HM-Sorten
Carbide grades
Δ 4 Wochen
4 weeks

Bestellnummer Part number	w	t _{max}	γ	α	β	HIS	ES15	ES1P
RS274.0247.04.SF	0,025	4	1,5°	47°	2°	274040R	▲	Δ
							P ● ●	● ●
							M ● ●	● ●
							K ○ ○	○ ○
							N · ·	· ·
							S · ·	· ·
							H · ·	· ·

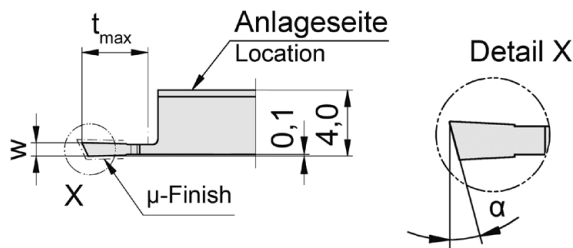
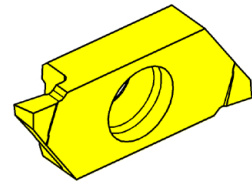
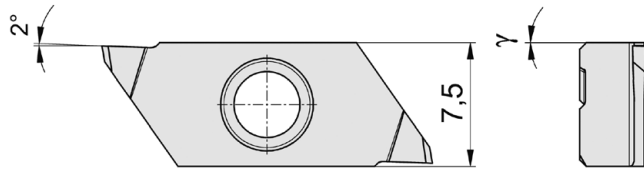
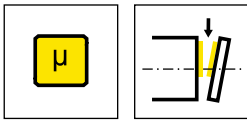

R = rechts wie gezeichnet
R = right hand version shown

L = links spiegelbildlich
L = left hand version

▲ ab Lager
on stock

HM-Sorten
Carbide grades
Δ 4 Wochen
4 weeks

Bestellnummer Part number	w	t _{max}	α	γ	HIS	MG12	ES15	ES1P
RS274.2508.04.SF	0,8	4	25°	0°	274040R	Δ	Δ	Δ
RS274.2509.04.SF	0,9	4	25°	0°	274040R		Δ	Δ
RS274.2510.04.SF	1	4	25°	0°	274040R		▲	Δ
RS274.2510.06.SF	1	6	25°	0°	274040R		Δ	Δ
RS274.2512.06.SF	1,2	6	25°	0°	274040R		Δ	Δ
RS274.2515.06.SF	1,5	6	25°	0°	274040R		Δ	Δ
LS274.2508.04.SF	0,8	4	25°	0°	274040L	Δ	Δ	Δ

t_{max} 6 mm nur bei Werkstück-Ø ≤ 25 mm erreichbar.
t_{max} 6 mm can be reached only with workpiece Ø ≤ 25 mm.

P	o	•	•
M	-	•	•
K	-	o	o
N	-	-	-
S	-	-	-
H	-	-	-

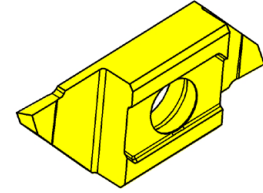
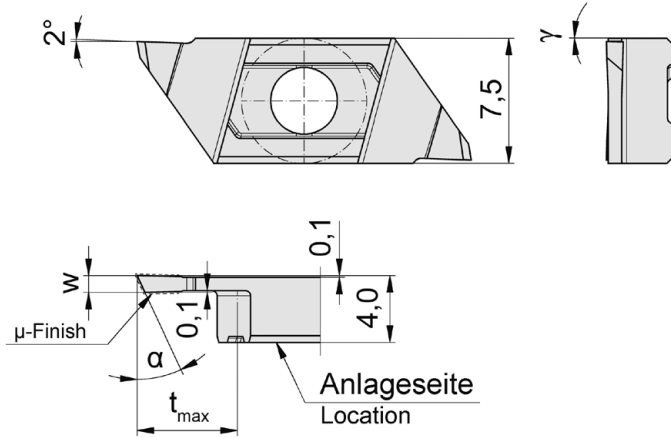
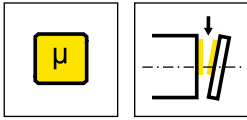

L = links wie gezeichnet
L = left hand version shown

▲ ab Lager
on stock

HM-Sorten
Carbide grades
Δ 4 Wochen
4 weeks

Bestellnummer Part number	w	t _{max}	α	γ	HIS	ES15	ES1P
LS274.2508.04.SF.R	0,8	4	25°	0°	274040L	Δ	Δ
LS274.2509.04.SF.R	0,9	4	25°	0°	274040L	Δ	Δ
LS274.2510.06.SF.R	1	6	25°	0°	274040L	Δ	Δ
LS274.2512.06.SF.R	1,2	6	25°	0°	274040L	Δ	Δ
LS274.2515.06.SF.R	1,5	6	25°	0°	274040L	▲	Δ

t_{max} 6 mm nur bei Werkstück-Ø ≤ 25 mm erreichbar.
t_{max} 6 mm can be reached only with workpiece Ø ≤ 25 mm.

P	●	●
M	●	●
K	○	○
N	-	-
S	-	-
H	-	-

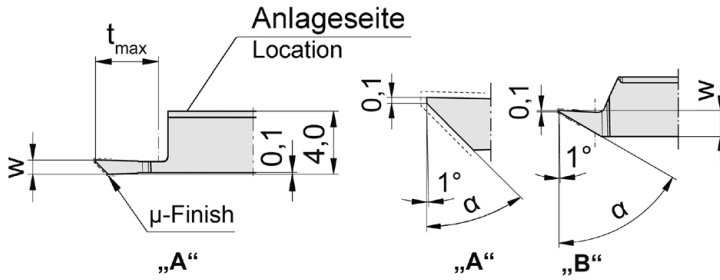
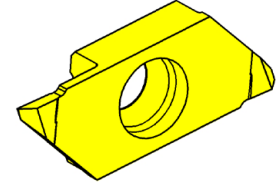
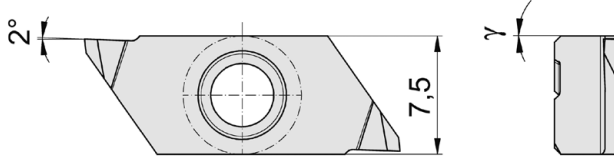
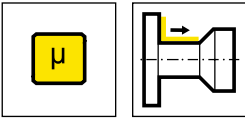

R = rechts wie gezeichnet
R = right hand version shown

L = links spiegelbildlich
L = left hand version

▲ ab Lager
on stock

HM-Sorten
Carbide grades
Δ 4 Wochen
4 weeks

Bestellnummer Part number	w	t _{max}	α	γ	Form	HIS	MG12	ES15	ES1P
RS274.4508.04.SF	0,8	4	45°	0°	A	274040R		Δ	Δ
RS274.4509.04.SF	0,9	4	45°	0°	A	274040R		▲	Δ
RS274.4510.06.SF	1	6	45°	0°	A	274040R		▲	Δ
RS274.4512.06.SF	1,2	6	45°	0°	A	274040R		Δ	Δ
RS274.6015.02.SF	1,8	2,5	60°	0°	B	274040R		▲	Δ
RS274.7010.02.SF	1,2	2,5	70°	0°	B	274040R		Δ	Δ
LS274.4509.04.SF	0,9	4	45°	0°	A	274040L	Δ	Δ	Δ
							P	o	•
							M	-	•
							K	-	o
							N	-	-
							S	-	-
							H	-	-

t_{max} 6 mm nur bei Werkstück-Ø ≤ 25 mm erreichbar.
t_{max} 6 mm can be reached only with workpiece Ø ≤ 25 mm.



Wendeschneidplatte

Indexable insert

S274...SF

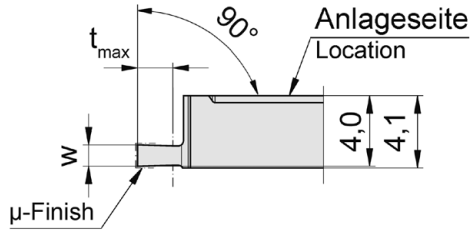
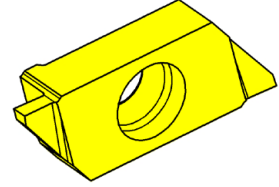
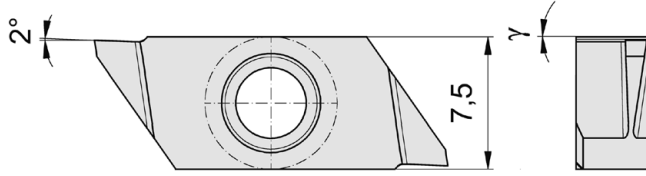
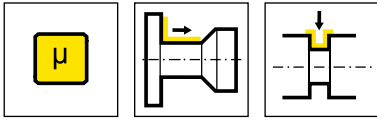

R = rechts wie gezeichnet
R = right hand version shown

▲ ab Lager
on stock

HM-Sorten
Carbide grades
Δ 4 Wochen
4 weeks

Bestellnummer Part number	w	t _{max}	γ	HIS	ES15	ES1P
RS274.0005.01.SF	0,5	1	0°	274040R	▲	Δ
RS274.0010.02.SF	1	2	0°	274040R	▲	Δ
RS274.0012.02.SF	1,2	2	0°	274040R	Δ	Δ
RS274.0015.03.SF	1,5	3	0°	274040R	Δ	Δ
RS274.0020.03.SF	2	3	0°	274040R	Δ	Δ
					P ● ●	
					M ● ●	
					K ○ ○	
					N - -	
					S - -	
					H - -	

312



**Klemmhalter und
Schneidplatten**

**Toolholder and
Inserts**

K

Geometrien und
Vorschübe
Geometries and feed rates

Seite/Page
494-495

Klemmhalter
Toolholder
L368/360/361/368
369/390/391/309

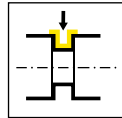

Seite/Page
496, 499-504,
507-508, 512-
513

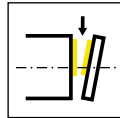

Seite/Page
505-506

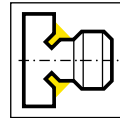

Seite/Page
514

Grundhalter
Basic toolholder
L760

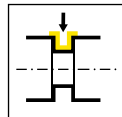

Seite/Page
497

Kassette
Cassette
NK368/LNK760

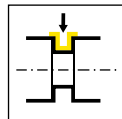

Seite/Page
498

Einbauhalter Graf
Cartridge Graf
64/65/99

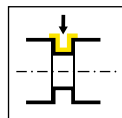

Seite/Page
509-510

Einstellbare Halter
Adjustable holder
N67/N68

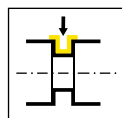

Seite/Page
511

Wendeschneidplatte
Indexable insert
S312/312

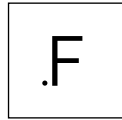

Seite/Page
515



Seite/Page
516

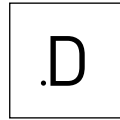

Seite/Page
517

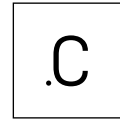

Seite/Page
518, 535

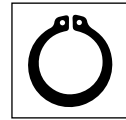

Seite/Page
519-523

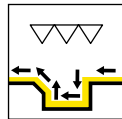

Seite/Page
524

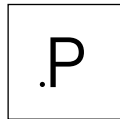

Seite/Page
525

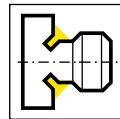

Seite/Page
526-527

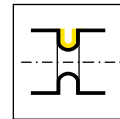

Seite/Page
528

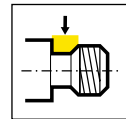

Seite/Page
529-530

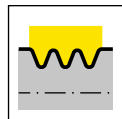

Seite/Page
531

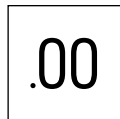

Seite/Page
532-533

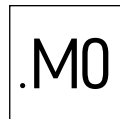

Seite/Page
534

Geometrien und Vorschübe

Geometries and feed rates



Geometrie Geometry	Werkstoff Material	Vorschubbereich f [mm/U] Feed rate f [mm/rev]	Bearbeitung Machining						
	<table border="1"> <tr> <td>P</td> <td>M</td> <td>K</td> </tr> <tr> <td>N</td> <td>S</td> <td>H</td> </tr> </table>	P	M	K	N	S	H	<p>↓ 0,03-0,15</p>	
P	M	K							
N	S	H							
	<table border="1"> <tr> <td>P</td> <td>M</td> <td>K</td> </tr> <tr> <td>N</td> <td>S</td> <td>H</td> </tr> </table>	P	M	K	N	S	H	<p>↓ 0,10-0,45</p> <p>↔ 0,15-0,60</p>	
P	M	K							
N	S	H							
	<table border="1"> <tr> <td>P</td> <td>M</td> <td>K</td> </tr> <tr> <td>N</td> <td>S</td> <td>H</td> </tr> </table>	P	M	K	N	S	H	<p>↓ 0,03-0,15</p> <p>↔ 0,05-0,20</p>	
P	M	K							
N	S	H							
	<table border="1"> <tr> <td>P</td> <td>M</td> <td>K</td> </tr> <tr> <td>N</td> <td>S</td> <td>H</td> </tr> </table>	P	M	K	N	S	H	<p>↓ 0,02-0,10</p>	
P	M	K							
N	S	H							
	<table border="1"> <tr> <td>P</td> <td>M</td> <td>K</td> </tr> <tr> <td>N</td> <td>S</td> <td>H</td> </tr> </table>	P	M	K	N	S	H	<p>↓ 0,02-0,08</p> <p>↔ 0,02-0,04</p>	
P	M	K							
N	S	H							

K

Geometrien und Vorschübe

Geometries and feed rates



Geometrie Geometry	Werkstoff Material	Vorschubbereich f [mm/U] Feed rate f [mm/rev]	Bearbeitung Machining						
	<table border="1"> <tr> <td>P</td> <td>M</td> <td>K</td> </tr> <tr> <td>N</td> <td>S</td> <td>H</td> </tr> </table>	P	M	K	N	S	H	<p>↓ 0,02-0,12</p>	
P	M	K							
N	S	H							
	<table border="1"> <tr> <td>P</td> <td>M</td> <td>K</td> </tr> <tr> <td>N</td> <td>S</td> <td>H</td> </tr> </table>	P	M	K	N	S	H	<p>↓ 0,02-0,10</p> <p>↔ 0,02-0,15</p>	
P	M	K							
N	S	H							



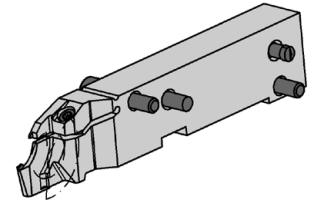
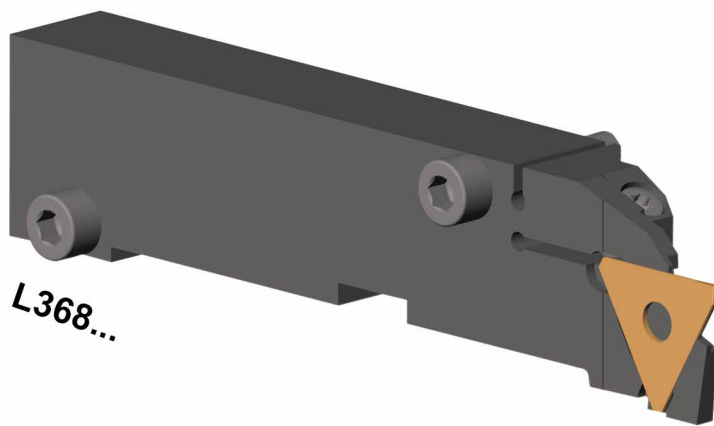
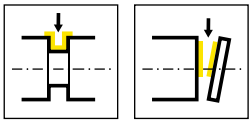

Bestellnummer Part number	t _{max}	w _{min}	w _{max}	Maschinentyp Machine type	Schneidplatte Insert
L368.0710.08	8	0,5	1,2	EvoDECO 10	R/L312.0805... R/L312.0808... R/L312.0510... R/L312.0512... R/L312.1012... 312.0012...
L368.0710.11	8	1,5	1,5	EvoDECO 10	R/L312.0515... 312.0015...

Werkzeug für Tornos
Tool for Tornos

K

Ersatzteile
Spare Parts

Klemmhalter Toolholder	Spannschraube Clamping Screw	TORX PLUS®-Schlüssel TORX PLUS® Wrench
L368...	4.18T15EP	T15PQ

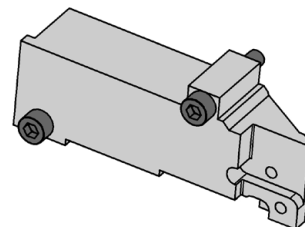
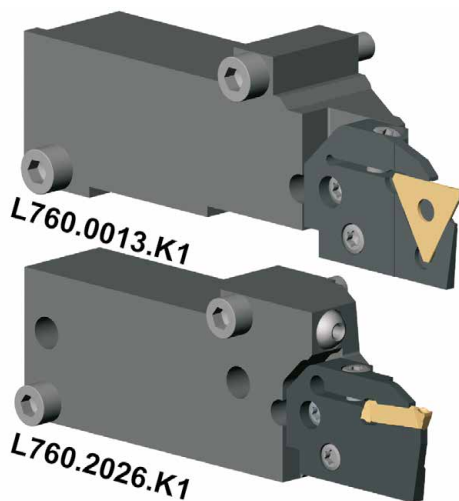
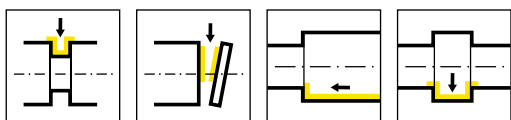

Bestellnummer Part number	t _{max}	w _{min}	w _{max}	Maschinentyp Machine type	Kassette Cassette	Schneidplatte Insert
L760.0013.K1	8	0,5	1,2	DECO 13	LNK368.0760.08	R/L312.0805... R/L312.0808... R/L312.0510... R/L312.0512... R/L312.1012... 312.0012...
L760.0013.K1	8	1,5	1,5	DECO 13	LNK368.0760.11	R/L312.0515... 312.0015...
L760.2026.K1	15	2,0 2,4 2,8	2,4 2,8 3,7	DECO 20/26	LNK760..0224.01 LNK760..0224.02 LNK760..0224.03	S224...

Werkzeug für Tornos
Tool for Tornos



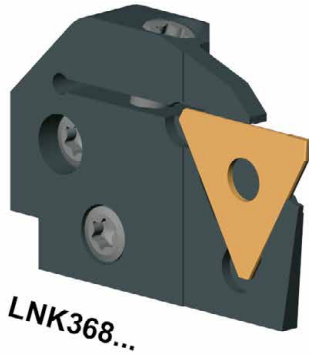
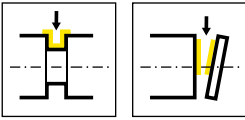

LNK368...



LNK760...

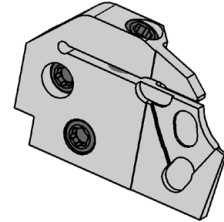

Bestellnummer Part number	t _{max}	W _{min}	W _{max}	Maschinentyp Machine type	Schneidplatte Insert
LNK368.0760.08	9	0,5	1,2	EvoDECO 16	R/L312.0805... R/L312.0808... R/L312.0510... R/L312.0512... R/L312.1012... 312.0012...
LNK368.0760.11	9	1,5	1,5	EvoDECO 16	R/L312.0515... 312.0015...
LNK760.0224.01	15	2	2,4	EvoDECO 20/EvoDECO 32	S224...
LNK760.0224.02	15	2,4	2,8	EvoDECO 20/EvoDECO 32	S224...
LNK760.0224.03	15	2,8	3,7	EvoDECO 20/EvoDECO 32	S224...

Werkzeug für Tornos
Tool for Tornos

K

Ersatzteile
Spare Parts

Kassette Cassette	Spannschraube Clamping Screw	TORX PLUS®-Schlüssel TORX PLUS® Wrench
LNK368.0760...	5.10T20P	T20PQ
LNK760.0224....	5.12T20P	T20PQ

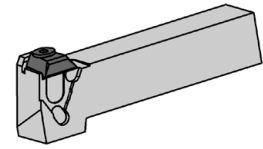
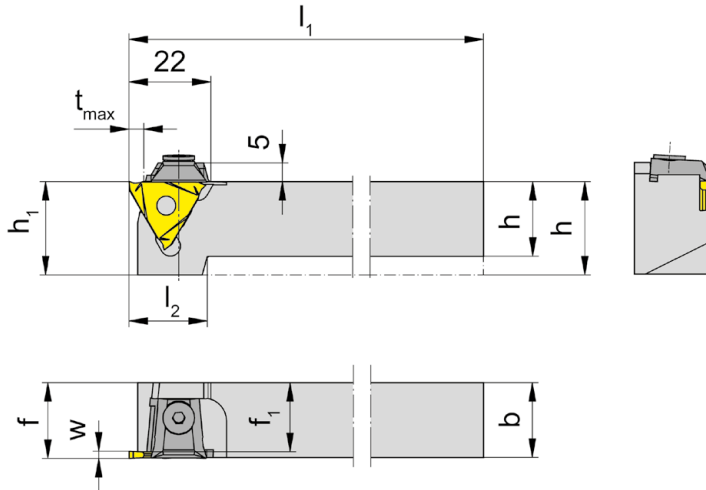
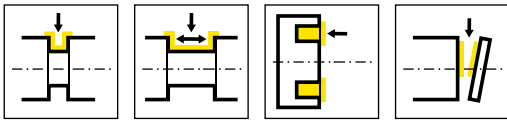

R = rechts wie gezeichnet
R = right hand version shown

L = links spiegelbildlich
L = left hand version

Bestellnummer Part number	h	b	l ₁	l ₂	h ₁	f ₁	f	t _{max}	HWS
R360.1212.01	12	12	100	24	25	10,5	f ₁ +w-a ₁	4	31201N • 31201R • 31201L • 31208N • 31211N
R360.1212.02	12	12	100	24	25	9,5	f ₁ +w-a ₁	6	31202N • 31202R • 31202L
R360.1616.01	16	16	125	22	25	14,5	f ₁ +w-a ₁	4	31201N • 31201R • 31201L • 31208N • 31211N
R360.1616.02	16	16	125	22	25	13,5	f ₁ +w-a ₁	6	31202N • 31202R • 31202L
R360.2020.01	20	20	125	21	25	18,5	f ₁ +w-a ₁	4	31201N • 31201R • 31201L • 31208N • 31211N
R360.2020.02	20	20	125	21	25	17,5	f ₁ +w-a ₁	6	31202N • 31202R • 31202L
L360.1212.01	12	12	100	24	25	10,5	f ₁ +w-a ₁	4	31201N • 31201R • 31201L • 31208N • 31211N
L360.1212.02	12	12	100	24	25	9,5	f ₁ +w-a ₁	6	31202N • 31202R • 31202L
L360.1616.01	16	16	125	22	25	14,5	f ₁ +w-a ₁	4	31201N • 31201R • 31201L • 31208N • 31211N
L360.1616.02	16	16	125	22	25	13,5	f ₁ +w-a ₁	6	31202N • 31202R • 31202L
L360.2020.01	20	20	125	21	25	18,5	f ₁ +w-a ₁	4	31201N • 31201R • 31201L • 31208N • 31211N
L360.2020.02	20	20	125	21	25	17,5	f ₁ +w-a ₁	6	31202N • 31202R • 31202L

w, a₁ siehe WSP
w, a₁ see indexable inserts

t_{max} nur bei Werkstück-Ø ≤ 40 mm erreichbar.
t_{max} can be reached only with workpiece Ø ≤ 40 mm

Ersatzteile

Spare Parts

Klemmhalter Toolholder	Spannelement Clamping element
R/L360....	11.3
R/L360.2020....	16.4

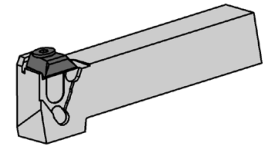
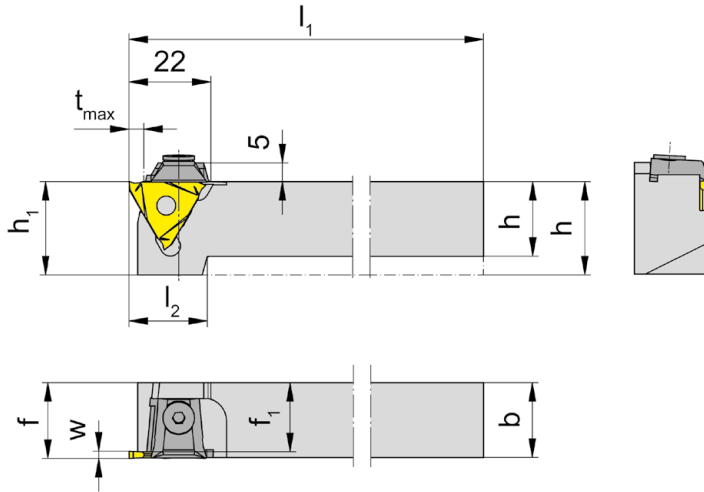
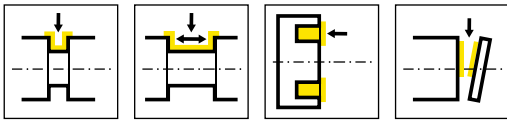

R = rechts wie gezeichnet
R = right hand version shown

L = links spiegelbildlich
L = left hand version

Bestellnummer Part number	h	b	l ₁	l ₂	h ₁	f ₁	f	t _{max}	HWS
R360.1212.03	12	12	100	24	25	8,5	f ₁ +w-a ₁	6	31203N • 31203R • 31203L
R360.1616.04	16	16	125	22	25	10,8	f ₁ +w-a ₁	6	31204N • 31204R • 31204L
R360.1616.03	16	16	125	22	25	12,5	f ₁ +w-a ₁	6	31203N • 31203R • 31203L
R360.2020.04	20	20	125	21	25	14,8	f ₁ +w-a ₁	6	31204N • 31204R • 31204L
R360.2020.03	20	20	125	21	25	16,5	f ₁ +w-a ₁	6	31203N • 31203R • 31203L
L360.1212.03	12	12	100	24	25	8,5	f ₁ +w-a ₁	6	31203N • 31203R • 31203L
L360.1616.04	16	16	125	22	25	10,8	f ₁ +w-a ₁	6	31204N • 31204R • 31204L
L360.1616.03	16	16	125	22	25	12,5	f ₁ +w-a ₁	6	31203N • 31203R • 31203L
L360.2020.04	20	20	125	21	25	14,8	f ₁ +w-a ₁	6	31204N • 31204R • 31204L
L360.2020.03	20	20	125	21	25	16,5	f ₁ +w-a ₁	6	31203N • 31203R • 31203L

w, a₁ siehe WSP
w, a₁ see indexable inserts

t_{max} nur bei Werkstück-Ø ≤ 40 mm erreichbar.
t_{max} can be reached only with workpiece Ø ≤ 40 mm

Ersatzteile

Spare Parts

Klemmhalter Toolholder	Spannelement Clamping element
R/L360....	11.3
R/L360.1616.04	13.4
R/L360.2020....	16.4

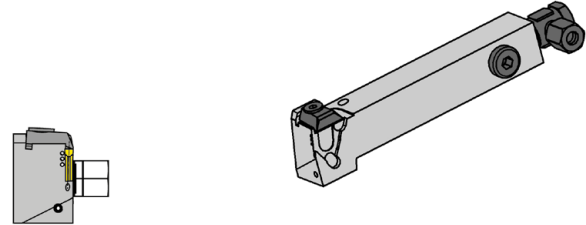
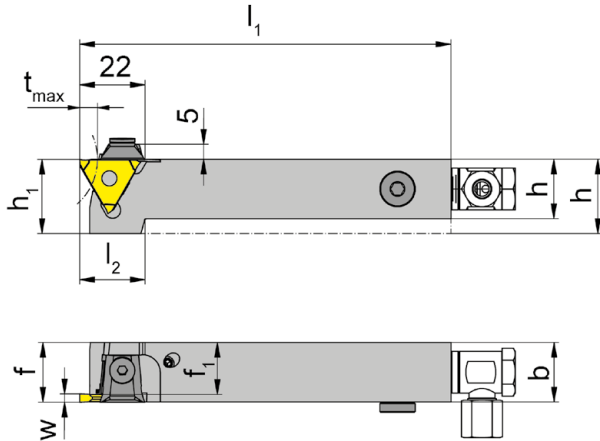
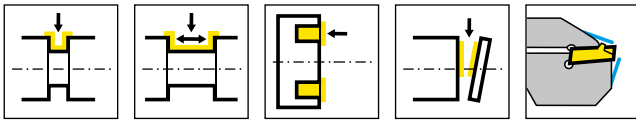

R = rechts wie gezeichnet
R = right hand version shown

L = links spiegelbildlich
L = left hand version

Bestellnummer Part number	h	b	l ₁	l ₂	h ₁	f ₁	f	t _{max}	HWS
R360.1212.01.IK	12	12	100	24	25	10,5	f ₁ +w-a ₁	4	31201N • 31201R • 31201L • 31208N • 31211N
R360.1616.01.IK	16	16	125	22	25	14,5	f ₁ +w-a ₁	4	31201N • 31201R • 31201L • 31208N • 31211N
R360.2020.01.IK	20	20	125	21	25	18,5	f ₁ +w-a ₁	4	31201N • 31201R • 31201L • 31208N • 31211N
R360.1212.02.IK	12	12	100	24	25	9,5	f ₁ +w-a ₁	6	31202N • 31202R • 31202L
R360.1616.02.IK	16	16	125	22	25	13,5	f ₁ +w-a ₁	6	31202N • 31202R • 31202L
R360.2020.02.IK	20	20	125	21	25	17,5	f ₁ +w-a ₁	6	31202N • 31202R • 31202L
L360.1212.01.IK	12	12	100	24	25	10,5	f ₁ +w-a ₁	4	31201N • 31201R • 31201L • 31208N • 31211N
L360.1616.01.IK	16	16	125	22	25	14,5	f ₁ +w-a ₁	4	31201N • 31201R • 31201L • 31208N • 31211N
L360.2020.01.IK	20	20	125	21	25	18,5	f ₁ +w-a ₁	4	31201N • 31201R • 31201L • 31208N • 31211N
L360.1212.02.IK	12	12	100	24	25	9,5	f ₁ +w-a ₁	6	31202N • 31202R • 31202L
L360.1616.02.IK	16	16	125	22	25	13,5	f ₁ +w-a ₁	6	31202N • 31202R • 31202L
L360.2020.02.IK	20	20	125	21	25	17,5	f ₁ +w-a ₁	6	31202N • 31202R • 31202L

w, a₁ siehe WSP
w, a₁ see indexable inserts

t_{max} nur bei Werkstück-Ø ≤ 40 mm erreichbar.
t_{max} can be reached only with workpiece Ø ≤ 40 mm

Ersatzteile

Spare Parts

Klemmhalter Toolholder	Kühlmittelanschluss Coolant supply	Spannelement Clamping element	Verschlusschraube Screw Plug
R/L360.1212....	004.00.22	11.3	
R/L360.1616.01.IK	004.00.16	11.3	004.00.26
R/L360.2020....	004.00.16	16.4	18.908
R/L360.1616.02.IK	004.00.16	11.3	18.908

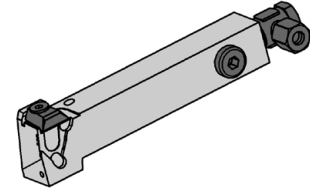
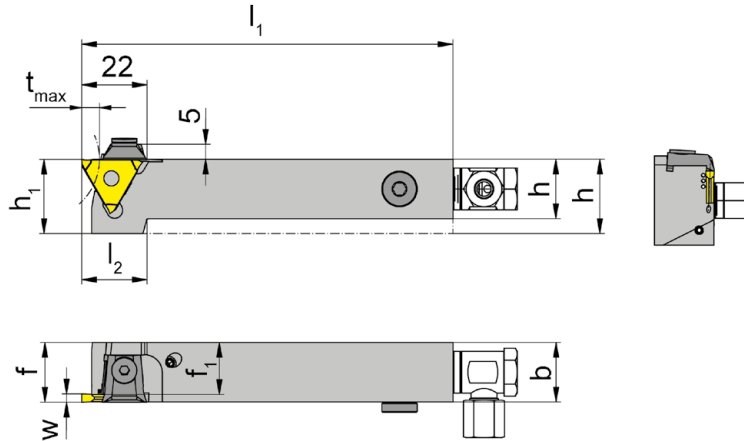
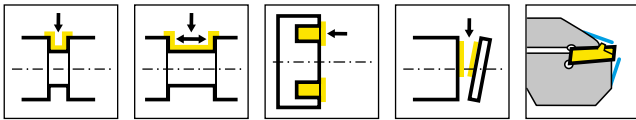

R = rechts wie gezeichnet
R = right hand version shown

L = links spiegelbildlich
L = left hand version

Bestellnummer Part number	h	b	l ₁	l ₂	h ₁	f ₁	f	t _{max}	HWS
R360.1212.03.IK	12	12	100	24	25	8,5	f ₁ +w-a ₁	6	31203N • 31203R • 31203L
R360.1616.03.IK	16	16	125	22	25	12,5	f ₁ +w-a ₁	6	31203N • 31203R • 31203L
R360.2020.03.IK	20	20	125	21	25	16,5	f ₁ +w-a ₁	6	31203N • 31203R • 31203L
R360.1616.04.IK	16	16	125	21	25	10,8	f ₁ +w-a ₁	6	31204N • 31204R • 31204L
R360.2020.04.IK	20	20	125	22	25	14,8	f ₁ +w-a ₁	6	31204N • 31204R • 31204L
L360.1212.03.IK	12	12	100	24	25	8,5	f ₁ +w-a ₁	6	31203N • 31203R • 31203L
L360.1616.03.IK	16	16	125	22	25	12,5	f ₁ +w-a ₁	6	31203N • 31203R • 31203L
L360.2020.03.IK	20	20	125	21	25	16,5	f ₁ +w-a ₁	6	31203N • 31203R • 31203L
L360.1616.04.IK	16	16	125	21	25	10,8	f ₁ +w-a ₁	6	31204N • 31204R • 31204L
L360.2020.04.IK	20	20	125	22	25	14,8	f ₁ +w-a ₁	6	31204N • 31204R • 31204L

w, a1 siehe WSP
w, a1 see indexable inserts

tmax nur bei Werkstück-Ø ≤ 40 mm erreichbar.
tmax can be reached only with workpiece Ø ≤ 40 mm

K

Ersatzteile

Spare Parts

Klemmhalter Toolholder	Kühlmittelanschluss Coolant supply	Spannelement Clamping element	Verschlusschraube Screw Plug
R/L360.1212.03.IK	004.00.22	11.3	
R/L360.1616.03.IK	004.00.16	11.3	004.00.26
R/L360.2020.03.IK	004.00.16	16.4	18.908
R/L360.1616.04.IK	004.00.16	13.4	004.00.26
R/L360.2020.04.IK	004.00.16	16.4	

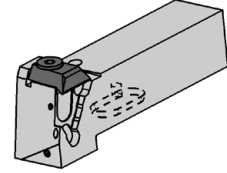
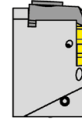
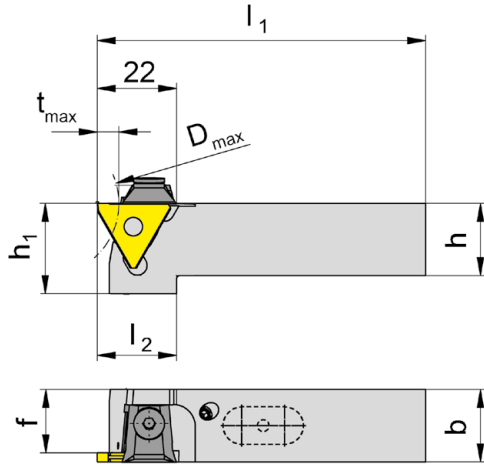
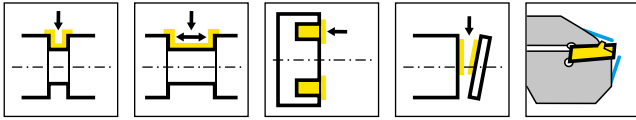

Bestellnummer Part number	h	b	l ₁	l ₂	h ₁	f	D _{max}	t _{max}	HWS
R360.2020.5.01.IK	20	20	91	22	25	18,5	40	4	31201N • 31201R • 31201L • 31208N • 31211N
R360.2020.5.02.IK	20	20	91	22	25	17,5	40	6	31202N • 31202R • 31202L
R360.2020.5.03.IK	20	20	91	22	25	16,5	40	6	31203N • 31203R • 31203L
R360.2020.5.04.IK	20	20	91	22	25	14,8	40	6	31204N • 31204R • 31204L
L360.2020.5.01.IK	20	20	91	22	25	18,5	40	4	31201N • 31201R • 31201L • 31208N • 31211N
L360.2020.5.02.IK	20	20	91	22	25	17,5	40	6	31202N • 31202R • 31202L
L360.2020.5.03.IK	20	20	91	22	25	16,5	40	6	31203N • 31203R • 31203L
L360.2020.5.04.IK	20	20	91	22	25	14,8	40	6	31204N • 31204R • 31204L

Ersatzteile

Spare Parts

Klemmhalter Toolholder	Spannelement Clamping element
R/L360...	16.4



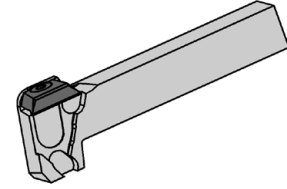
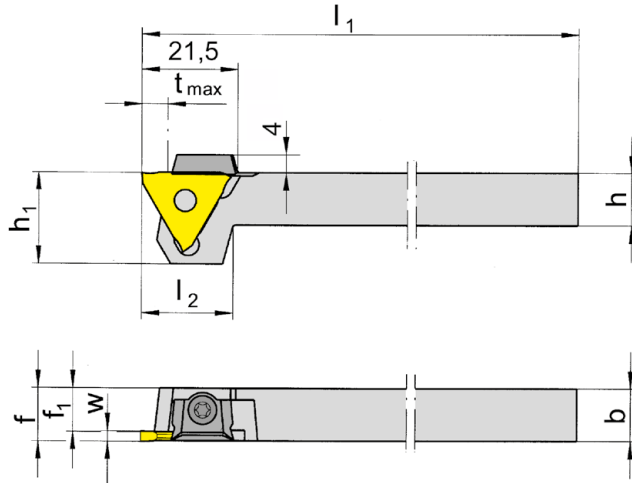
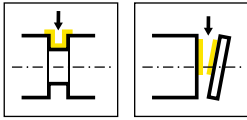

R = rechts wie gezeichnet
R = right hand version shown

L = links spiegelbildlich
L = left hand version

Bestellnummer Part number	h	b	l ₁	l ₂	h ₁	f ₁	f	t _{max}	HWS
R361.1212.01	12	12	100	17	19	10,5	f ₁ +w-a ₁	4	31201N • 31201R • 31201L • 31208N • 31211N
R361.1212.02	12	12	100	17	19	9,5	f ₁ +w-a ₁	6	31202N • 31202R • 31202L
R361.1212.03	12	12	100	21	21	8,5	f ₁ +w-a ₁	6	31203N • 31203R • 31203L
L361.1212.01	12	12	100	17	19	10,5	f ₁ +w-a ₁	4	31201N • 31201R • 31201L • 31208N • 31211N
L361.1212.02	12	12	100	17	19	9,5	f ₁ +w-a ₁	6	31202N • 31202R • 31202L
L361.1212.03	12	12	100	21	21	8,5	f ₁ +w-a ₁	6	31203N • 31203R • 31203L

w, a₁ siehe WSP
w, a₁ see indexable inserts

t_{max} nur bei Werkstück-Ø ≤ 40 mm erreichbar.
t_{max} can be reached only with workpiece Ø ≤ 40 mm

Ersatzteile

Spare Parts

Klemmhalter Toolholder	Spannelement Clamping element	Spannschraube Clamping Screw	TORX PLUS®-Schlüssel TORX PLUS® Wrench
R/L361...	12.3	030.0422.T10P	T10PL

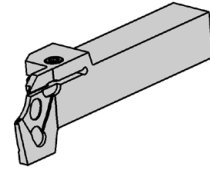
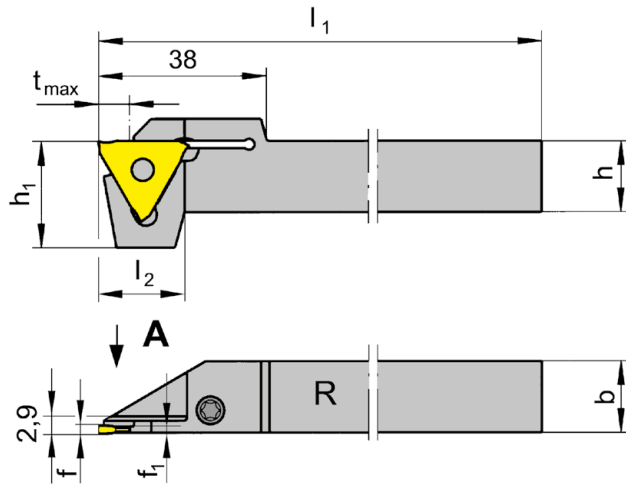
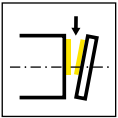

R = rechts wie gezeichnet
R = right hand version shown

L = links spiegelbildlich
L = left hand version

Bestellnummer Part number	h	b	l ₁	l ₂	h ₁	f ₁	f	t _{max}	HWS
R368.1212.08	12	12	95	19,5	24	1	f ₁ +a ₁	8	31208N
R368.1616.08	16	16	95	19,5	24	1	f ₁ +a ₁	8	31208N
R368.1212.11	12	12	95	19,5	24	1,3	f ₁ +a ₁	8	31211N
R368.1616.11	16	16	95	19,5	24	1,3	f ₁ +a ₁	8	31211N
L368.1212.08	12	12	95	19,5	24	1	f ₁ +a ₁	8	31208N
L368.1616.08	16	16	95	19,5	24	1	f ₁ +a ₁	8	31208N
L368.1212.11	12	12	95	19,5	24	1,3	f ₁ +a ₁	8	31211N
L368.1616.11	16	16	95	19,5	24	1,3	f ₁ +a ₁	8	31211N

für TRAUB-Maschinen (TNL12/7)
for machines TRAUB (TNL12/7)

a1 siehe WSP
a1 see indexable inserts

Ersatzteile
Spare Parts

Klemmhalter Toolholder	Spannschraube Clamping Screw	TORX PLUS®-Schlüssel TORX PLUS® Wrench
R/L368...	4.15T15P	T15PQ



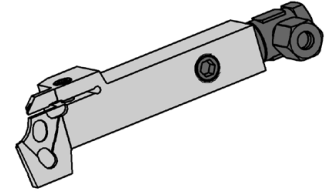
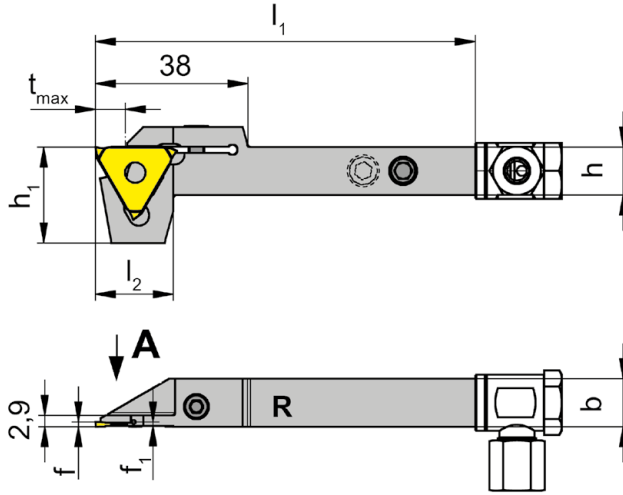
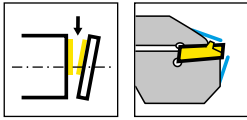

R = rechts wie gezeichnet
R = right hand version shown

L = links spiegelbildlich
L = left hand version

Bestellnummer Part number	h	b	l ₁	l ₂	h ₁	f ₁	f	t _{max}	HWS
R368.1212.08.IK	12	12	95	19,5	24	1	f ₁ +a ₁	8	31208N
R368.1616.08.IK	16	16	95	19,5	24	1	f ₁ +a ₁	8	31208N
R368.1212.11.IK	12	12	95	19,5	24	1,3	f ₁ +a ₁	8	31211N
R368.1616.11.IK	16	16	95	19,5	24	1,3	f ₁ +a ₁	8	31211N
L368.1212.08.IK	12	12	95	19,5	24	1	f ₁ +a ₁	8	31208N
L368.1616.08.IK	16	16	95	19,5	24	1	f ₁ +a ₁	8	31208N
L368.1212.11.IK	12	12	95	19,5	24	1,3	f ₁ +a ₁	8	31211N
L368.1616.11.IK	16	16	95	19,5	24	1,3	f ₁ +a ₁	8	31211N

für TRAUB-Maschinen (TNL12/7)
for machines TRAUB (TNL12/7)

a1 siehe WSP
a1 see indexable inserts



Ersatzteile
Spare Parts

Klemmhalter Toolholder	Spannschraube Clamping Screw	Kühlmittelanschluss Coolant supply	TORX PLUS®-Schlüssel TORX PLUS® Wrench
R/L368.1212...	4.15T15P	004.00.22	T15PQ
R/L368.1616...	4.15T15P	004.00.16	T15PQ

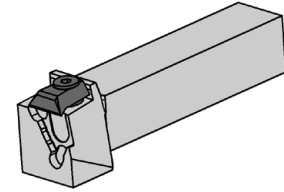
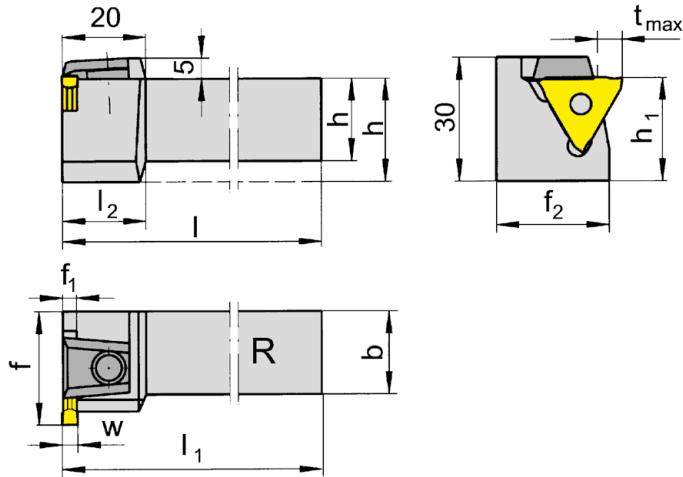
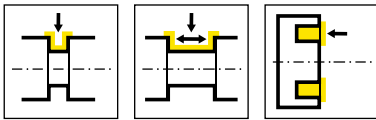

R = rechts wie gezeichnet
R = right hand version shown

L = links spiegelbildlich
L = left hand version

Bestellnummer Part number	h	b	l	l ₁	l ₂	h ₁	f	t _{max}	f ₁	f ₂	HWS
R369.2020.01	20	20	125	l-f ₁ +w-a ₁	20	25	27	4	1,5	23,5	31201N • 31201R • 31201L • 31208N • 31211N
R369.2020.02	20	20	125	l-f ₁ +w-a ₁	20	25	27	6	2,5	23,5	31202N • 31202R • 31202L
R369.2020.03	20	20	125	l-f ₁ +w-a ₁	20	25	27	6	3,5	23,5	31203N • 31203R • 31203L
R369.2020.04	20	20	125	l-f ₁ +w-a ₁	20	25	27	6	4,5	23,5	31204N • 31204R • 31204L
L369.2020.01	20	20	125	l-f ₁ +w-a ₁	20	25	27	4	1,5	23,5	31201N • 31201R • 31201L • 31208N • 31211N
L369.2020.02	20	20	125	l-f ₁ +w-a ₁	20	25	27	6	2,5	23,5	31202N • 31202R • 31202L
L369.2020.03	20	20	125	l-f ₁ +w-a ₁	20	25	27	6	3,5	23,5	31203N • 31203R • 31203L
L369.2020.04	20	20	125	l-f ₁ +w-a ₁	20	25	27	6	4,5	23,5	31204N • 31204R • 31204L

w, a1 siehe WSP
w, a1 see indexable inserts

tmax nur bei Werkstück-Ø ≤ 40 mm erreichbar.
tmax can be reached only with workpiece Ø ≤ 40 mm

Ersatzteile

Spare Parts

Klemmhalter Toolholder	Spannelement Clamping element
R/L369...	16.4

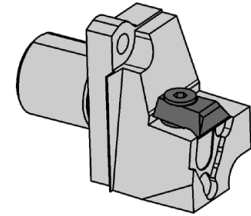
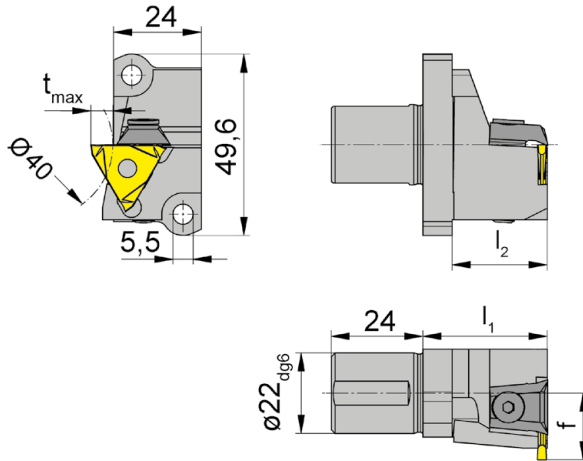
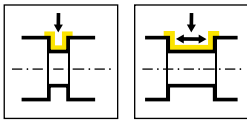

L = links wie gezeichnet
L = left hand version shown

Bestellnummer Part number	l_2	f	t_{max}	l_1	HWS	HMS
L369.A022.18.01	26	18,2	4	34	31201N • 31201R • 31201L • 31208N • 31211N	Star
L369.A022.18.02	26	18,2	6	34	31202N • 31202R • 31202L	Star

Star Langdrehautomaten:

ECAS-12/20, SB16D/E, SR-20, SR20J/JN, RS-20RII, RS-20RIII, RS-20RIV, RS-32J/JN, SW-12RIII

Swiss Type Machines Star:

ECAS-12/20, SB16D/E, SR-20, SR20J/JN, RS-20RII, RS-20RIII, RS-20RIV, RS-32J/JN, SW-12RII

Ersatzteile

Spare Parts

Klemmhalter Toolholder	Spannelement Clamping element
L369...	16.4

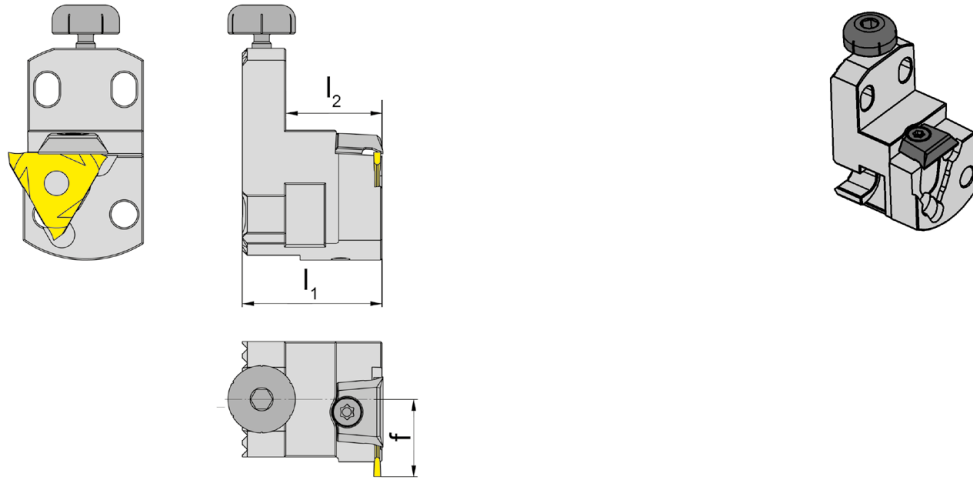
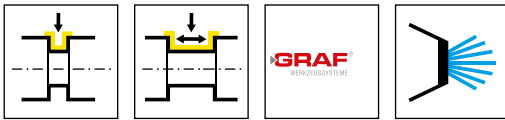

R = rechts wie gezeichnet
R = right hand version shown

L = links spiegelbildlich
L = left hand version

Bestellnummer Part number	l_1	l_2	f	HWS
R.64	29	20	16	31201N • 31201R • 31201L • 31208N • 31211N
R.65	29	20	16	31202N • 31202R • 31202L
R.64.IK	40	12	16	31201N • 31201R • 31201L • 31208N • 31211N
R.65.IK	40	12	16	31202N • 31202R • 31202L
L.64	29	20	16	31201N • 31201R • 31201L • 31208N • 31211N
L.65	29	20	16	31202N • 31202R • 31202L
L.64.IK	40	12	16	31201N • 31201R • 31201L • 31208N • 31211N
L.65.IK	40	12	16	31202N • 31202R • 31202L

Ersatzteile

Spare Parts

Einbauhalter Graf Cartridge Graf	Spannelement Clamping element	Kühlmittelschluss Coolant supply
R/L....	12.3	
R/L....IK	4082.R/L	004.00.19



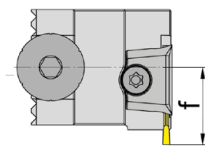
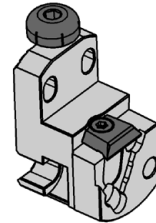
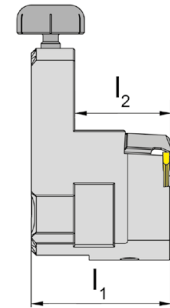
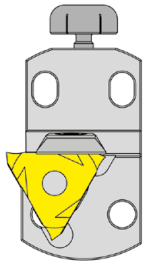
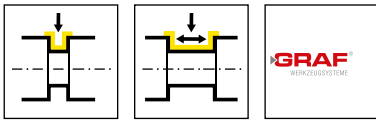

R = rechts wie gezeichnet
R = right hand version shown

L = links spiegelbildlich
L = left hand version

Bestellnummer Part number	l_1	l_2	f	HWS
R.99	29	20	16	31203N • 31203R • 31203L
L.99	29	20	16	31203N • 31203R • 31203L

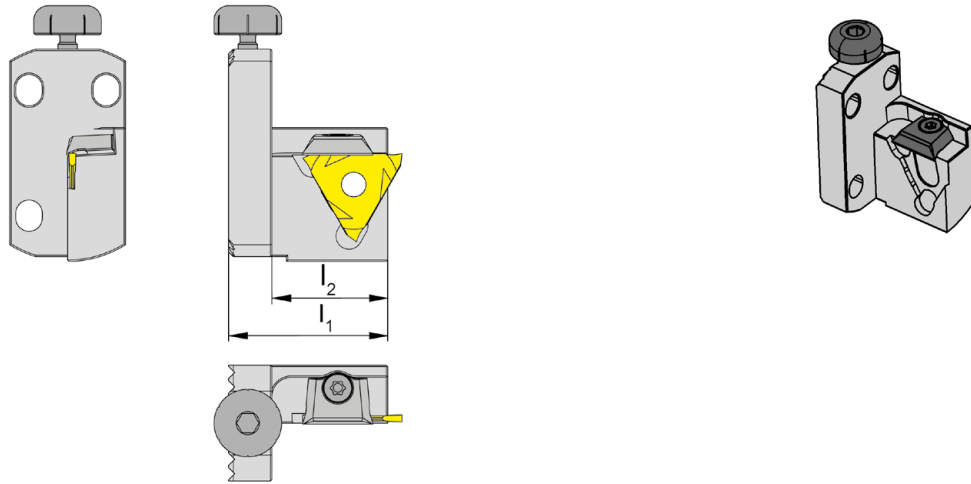
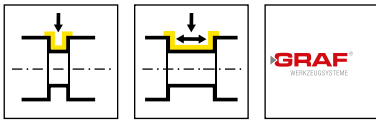

Bestellnummer Part number	l_1	l_2	HWS
N.67	33	29	31201N • 31201R • 31201L • 31208N • 31211N
N.68	33	29	31202N • 31202R • 31202L

Ersatzteile
Spare Parts

Einstellbare Halter Adjustable holder	Spannelement Clamping element
N.67	12.3
N.68	



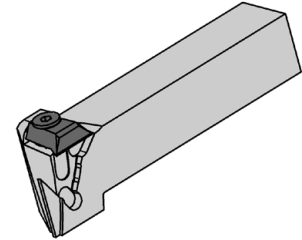
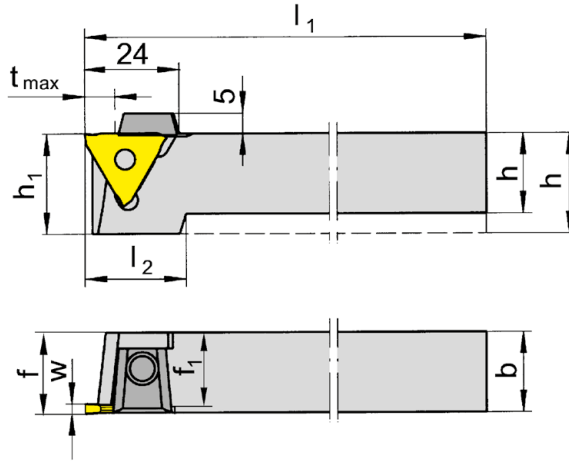
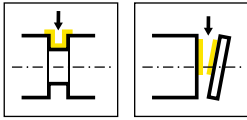

R = rechts wie gezeichnet
R = right hand version shown

L = links spiegelbildlich
L = left hand version

Bestellnummer Part number	h	b	l ₁	l ₂	h ₁	f ₁	f	t _{max}	HWS
R390.2020.01	20	20	125	22	25	18,5	f ₁ +w-a ₁	8	31201N • 31201R • 31201L
R390.2020.02	20	20	125	22	25	17,5	f ₁ +w-a ₁	8	31202N • 31202R • 31202L
R390.2020.03	20	20	125	22	25	16,5	f ₁ +w-a ₁	8	31203N • 31203R • 31203L
R390.2020.04	20	20	125	22	25	14,8	f ₁ +w-a ₁	8	31204N • 31204R • 31204L
L390.2020.01	20	20	125	22	25	18,5	f ₁ +w-a ₁	8	31201N • 31201R • 31201L
L390.2020.02	20	20	125	22	25	17,5	f ₁ +w-a ₁	8	31202N • 31202R • 31202L
L390.2020.03	20	20	125	22	25	16,5	f ₁ +w-a ₁	8	31203N • 31203R • 31203L
L390.2020.04	20	20	125	22	25	14,8	f ₁ +w-a ₁	8	31204N • 31204R • 31204L

w, a1 siehe WSP
w, a1 see indexable inserts

tmax nur bei Werkstück-Ø ≤ 125 mm erreichbar.
tmax can be reached only with workpiece Ø ≤ 125 mm

Ersatzteile

Spare Parts

Klemmhalter Toolholder	Spannelement Clamping element
R/L390...	16.4

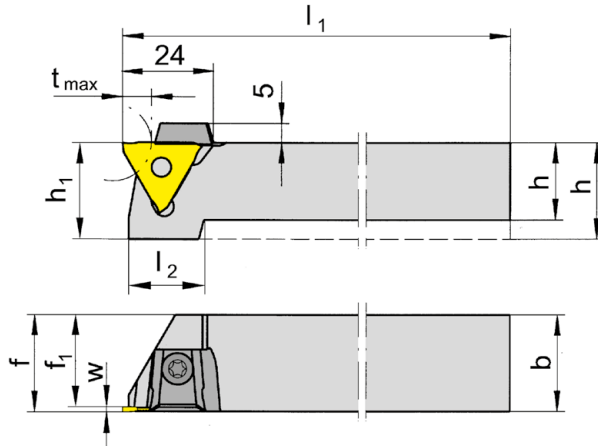
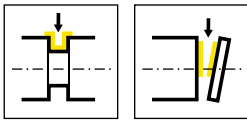

R = rechts wie gezeichnet
R = right hand version shown

L = links spiegelbildlich
L = left hand version

Bestellnummer Part number	h	b	l ₁	l ₂	h ₁	f ₁	f	t _{max}	HWS
R391.1212.01	12	12	100	21	21	10,5	f ₁ +w-a ₁	8	31201N • 31201R • 31201L • 31208N • 31211N
R391.1616.01	16	16	125	21	21	14,5	f ₁ +w-a ₁	8	31201N • 31201R • 31201L • 31208N • 31211N
R391.2020.01	20	20	125	21	21	18,5	f ₁ +w-a ₁	8	31201N • 31201R • 31201L • 31208N • 31211N
L391.1212.01	12	12	100	21	21	10,5	f ₁ +w-a ₁	8	31201N • 31201R • 31201L • 31208N • 31211N
L391.1616.01	16	16	125	21	21	14,5	f ₁ +w-a ₁	8	31201N • 31201R • 31201L • 31208N • 31211N
L391.2020.01	20	20	125	21	21	18,5	f ₁ +w-a ₁	8	31201N • 31201R • 31201L • 31208N • 31211N

w, a₁ siehe WSP
w, a₁ see indexable inserts

t_{max} nur bei Werkstück-Ø ≤ 20 mm erreichbar.
t_{max} can be reached only with workpiece Ø ≤ 20 mm

Ersatzteile

Spare Parts

Klemmhalter Toolholder	Spannelement Clamping element	TORX PLUS®-Schlüssel TORX PLUS® Wrench
R/L391.1212.01	12.3	T10PL
R/L391.1616.01	14.4	T15PQ
R/L391.2020.01	16.4	

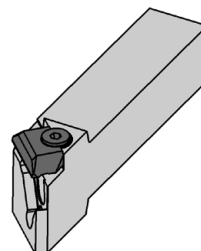
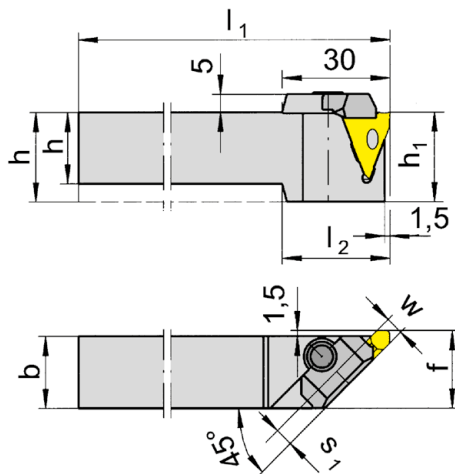
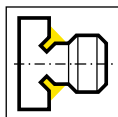

R = rechts wie gezeichnet
R = right hand version shown

L = links spiegelbildlich
L = left hand version

Bestellnummer Part number	h	b	l ₁	l ₂	h ₁	f	s ₁	HWS
R309.1616.01	16	16	125	30	25	21,5	1,5	31201N • 31201R • 31201L
R309.2020.02	20	20	125	30	25	21,5	2,5	31202N • 31202R • 31202L
R309.2020.03	20	20	125	30	25	21,5	3,5	31203N • 31203R • 31203L
R309.2020.04	20	20	125	30	25	21,5	5,2	31204N • 31204R • 31204L
L309.1616.01	16	16	125	30	25	21,5	1,5	31201N • 31201R • 31201L
L309.2020.02	20	20	125	30	25	21,5	2,5	31202N • 31202R • 31202L
L309.2020.03	20	20	125	30	25	21,5	3,5	31203N • 31203R • 31203L
L309.2020.04	20	20	125	30	25	21,5	5,2	31204N • 31204R • 31204L

w siehe WSP
w see indexable inserts

Ersatzteile

Spare Parts

Klemmhalter Toolholder	Spannelement Clamping element
R/L309...	21.4

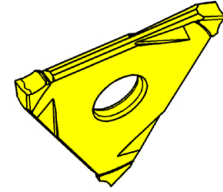
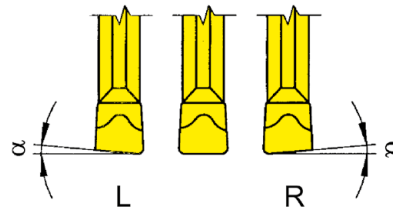
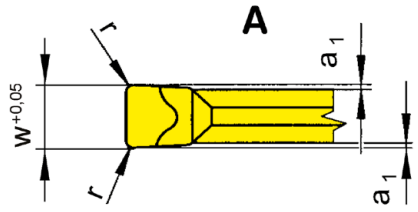
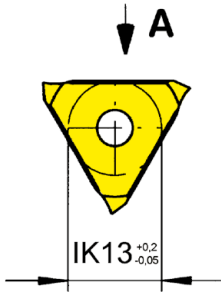
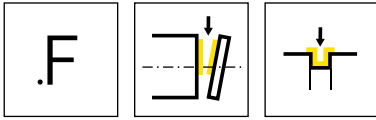

R = rechts wie gezeichnet
R = right hand version shown

L = links spiegelbildlich
L = left hand version

▲ ab Lager
on stock

HM-Sorten
Carbide grades

△ 4 Wochen
4 weeks

Bestellnummer Part number	w	r	α	a ₁	HIS	AL96	EG56	TC92	TF45	TF46	TI25
RS312.0520.F2	2	0,2	5°	0,25	31202N		▲			▲	▲
RS312.0525.F2	2,5	0,2	5°	0,25	31202N		▲			▲	▲
LS312.0520.F2	2	0,2	5°	0,25	31202N		▲			▲	▲
LS312.0525.F2	2,5	0,2	5°	0,25	31202N		▲			▲	▲
S312.0200.F2	2	0,2	0°	0,25	31202N	▲	▲	▲	▲	▲	▲
S312.0250.F2	2,5	0,2	0°	0,25	31202N	▲	▲	▲	▲	▲	▲
S312.0400.F2	4	0,2	0°	0,25	31204N		▲			▲	▲
S312.0400.F4	4	0,4	0°	0,25	31204N		▲			▲	▲
S312.0500.F2	5	0,2	0°	0,25	31204N		▲			▲	▲
S312.0500.F4	5	0,4	0°	0,25	31204N		▲			▲	▲
P	●	●	●	●	●	●	●	●	●	●	●
M	-	○	-	●	○	●					
K	●	○	-	●	●	●					
N	●	-	-	●	●	●					
S	-	-	-	●	○	●					
H	-	-	-	-	-	-					

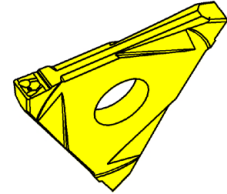
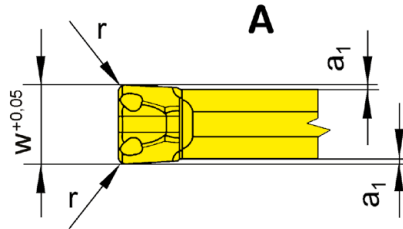
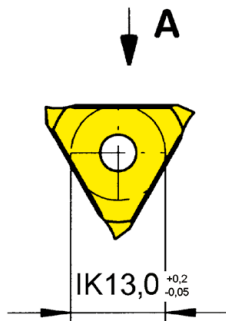
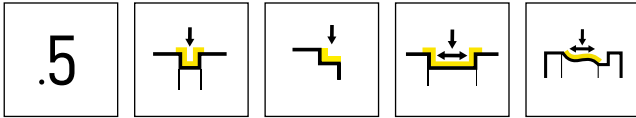

HM-Sorten
Carbide grades

▲ ab Lager
on stock

△ 4 Wochen
4 weeks

Bestellnummer Part number	w	r	a ₁	HIS	HM-Sorten Carbide grades										
					AL96	AS62	AS66	EG56	TC92	TF45	TF46	TI25	TN32	TN35	
S312.0250.52	2,5	0,2	0,25	31202N	▲	▲	▲	▲	△	▲	▲	▲	▲	▲	
S312.0250.54	2,5	0,4	0,25	31202N	△	▲	▲	▲	△	▲	▲	▲	▲	▲	▲
S312.0300.52	3	0,2	0,25	31203N	△	▲	▲	▲	△	▲	▲	▲	▲	▲	
S312.0300.54	3	0,4	0,25	31203N	△	▲	▲	▲	△	△	▲	▲	▲	▲	
S312.0400.52	4	0,2	0,25	31204N		▲	▲	▲			▲	▲	▲	△	
S312.0400.54	4	0,4	0,25	31204N		▲	▲	▲			▲	▲	▲	▲	
S312.0500.52	5	0,2	0,25	31204N		▲	▲	▲			▲	▲	△	△	
S312.0500.54	5	0,4	0,25	31204N		▲	▲	△			▲	▲	△	△	
P	●	●	●	●	●	●	●	●	●	●	●	●	●	●	●
M	-	-	○	○	-	●	○	●	-	○	●	●	-	-	●
K	●	-	●	○	-	●	○	●	-	●	●	●	-	-	●
N	●	-	●	-	-	●	-	-	-	●	●	●	-	-	●
S	-	-	○	-	-	●	-	-	-	○	●	●	-	-	●
H	-	-	-	-	-	-	-	-	-	-	-	-	-	-	-

K

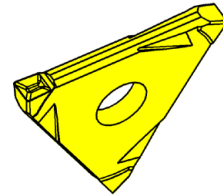
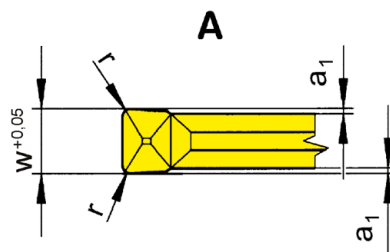
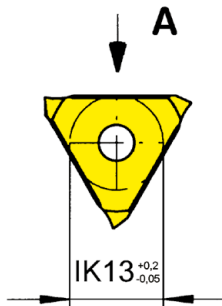
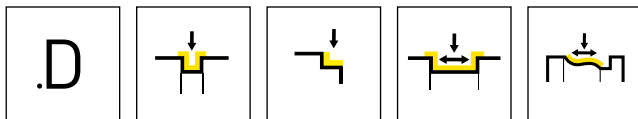

HM-Sorten
Carbide grades

▲ ab Lager
on stock

△ 4 Wochen
4 weeks

Bestellnummer Part number	w	r	a ₁	HIS	AL96	AS62	AS66	EG56	TC92	TF45	TF46	TI25	TN32
					S312.0200.D2	2	0,2	0,25	31202N	△	▲	▲	▲
S312.0200.D4	2	0,4	0,25	31202N	△	▲	▲	▲	△	△	△	▲	▲
S312.0250.D2	2,5	0,2	0,25	31202N	△	▲	▲	▲	▲	▲	▲	▲	▲
S312.0250.D4	2,5	0,4	0,25	31202N	△	▲	▲	▲	▲	▲	▲	▲	▲
S312.0300.D2	3	0,2	0,25	31203N	△	△	▲	▲	△	▲	▲	▲	▲
S312.0300.D4	3	0,4	0,25	31203N	△	▲	▲	▲	△	△	△	△	▲
P					●	●	●	●	●	●	●	●	●
M					-	-	○	○	-	●	○	●	-
K					●	-	●	○	-	●	●	●	-
N					●	-	●	-	-	●	●	●	-
S					-	-	○	-	-	●	○	●	-
H					-	-	-	-	-	-	-	-	-



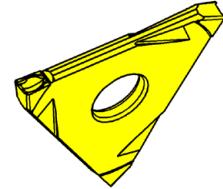
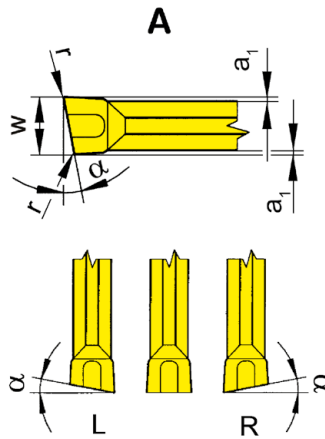
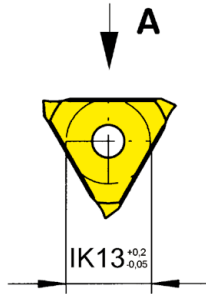
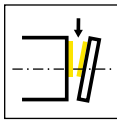
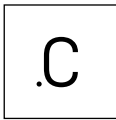

R = rechts wie gezeichnet
R = right hand version shown

L = links spiegelbildlich
L = left hand version

▲ ab Lager
on stock

HM-Sorten
Carbide grades
Δ 4 Wochen
4 weeks

Bestellnummer Part number	w	r	α	a ₁	HIS	EG55	TF46	TI25
RS312.0520.C2	2	0,2	5°	0,25	31202N	▲	▲	▲
RS312.0525.C2	2,5	0,2	5°	0,25	31202N	Δ	▲	▲
RS312.0530.C2	3	0,2	5°	0,25	31203N	Δ	Δ	▲
LS312.0520.C2	2	0,2	5°	0,25	31202N	▲	Δ	▲
LS312.0525.C2	2,5	0,2	5°	0,25	31202N		Δ	▲
LS312.0530.C2	3	0,2	5°	0,25	31203N	Δ		Δ
S312.0200.C2	2	0,2	0°	0,25	31202N	▲	▲	▲
S312.0250.C2	2,5	0,2	0°	0,25	31202N	▲	Δ	▲
S312.0300.C2	3	0,2	0°	0,25	31203N	Δ	Δ	Δ
P	●	●	●					
M	○	○	●					
K	○	●	●					
N	-	●	●					
S	-	○	●					
H	-	-	-					

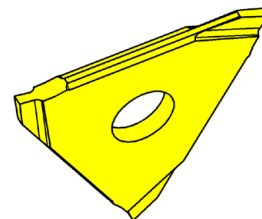
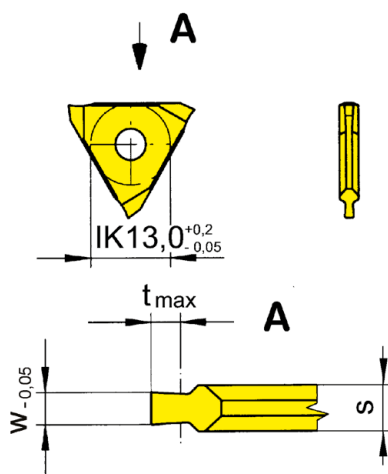
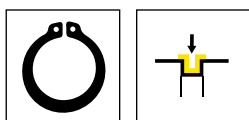

▲ ab Lager
on stock

HM-Sorten
Carbide grades

△ 4 Wochen
4 weeks

Bestellnummer Part number	w	Nw	t _{max}	s	HIS	EG35	EG52	TN32
312.0034.15	0,38	0,34	0,6	1,5	31201N	△		
312.0044.15	0,44	0,4	0,7	1,5	31201N	△		
312.0050.15	0,57	0,5	0,7	1,5	31201N		▲	▲
312.0060.15	0,67	0,6	0,8	1,5	31201N		▲	▲
312.0070.15	0,77	0,7	1,1	1,5	31201N		▲	▲
312.0080.15	0,87	0,8	1,2	1,5	31201N		▲	▲
312.0090.15	0,97	0,9	1,4	1,5	31201N		▲	▲
312.0100.15	1,07	1	1,6	1,5	31201N		▲	▲
						P	●	●
						M	●	○
						K	○	-
						N	-	-
						S	-	-
						H	-	-



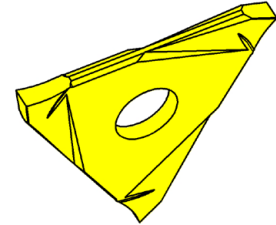
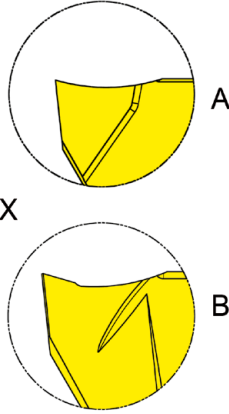
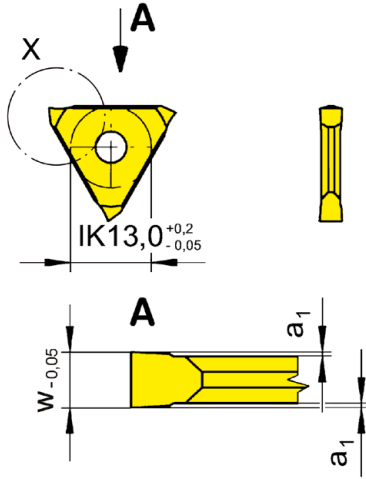
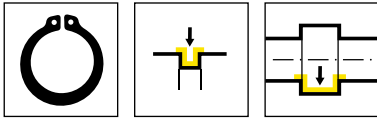

Form A = komplett geschliffen
Form A = completely ground

Form B = teilgeschliffen
Form B = partially ground

▲ ab Lager
on stock

△ 4 Wochen
4 weeks

HM-Sorten
Carbide grades

Bestellnummer Part number	w	Nw	a ₁	Form	HIS	K10	MG12	P20	EG35	EG55	EG56	HS32	HS36	TA45	TC92	TF45	TF46	TI25	TN32	TN35	H20	
312.0050.00	0,57	0,5	0,07	A	31201N	▲		▲		▲						▲	▲		▲			
312.0060.00	0,67	0,6	0,07	A	31201N	▲		▲		▲						▲	▲		▲			
312.0070.00	0,77	0,7	0,08	A	31201N	▲		▲		▲						▲	▲		▲			
312.0080.00	0,87	0,8	0,08	A	31201N	▲		▲		▲						▲	▲		▲			
312.0090.00	0,97	0,9	0,08	A	31201N	▲		▲		▲						▲	▲		▲		▲	
312.0100.00	1,07	1	0,09	A	31201N	▲		▲		▲						▲	▲		▲		▲	△
312.0110.00	1,24	1,1	0,2	A	31201N	▲		▲		▲		△	△			▲	▲		▲		▲	
312.0130.00	1,44	1,3	0,2	A	31201N	▲		▲		▲						▲	▲		▲		▲	
312.0160.00	1,74	1,6	0,2	A	31201N	▲		▲		▲						▲	▲		▲		▲	
312.0185.00	1,99	1,85	0,2	B	31201N	▲	▲	▲		▲	△					▲	▲	▲	▲		▲	▲
312.0215.00	2,29	2,15	0,2	B	31202N	▲	▲	▲		▲				▲		▲	▲	▲	▲		▲	▲
312.0265.00	2,79	2,65	0,2	B	31202N	▲	▲	▲		▲				△		▲	▲	▲	▲		▲	▲
312.0315.00	3,29	3,15	0,2	B	31203N	▲		▲		▲						▲	▲	▲	▲		▲	▲
312.0415.00	4,29	4,15	0,2	B	31204N	▲		▲		▲						▲	▲	▲	▲		▲	▲
312.0515.00	5,29	5,15	0,2	B	31204N	▲		▲	▲	▲					△	▲	▲	▲	▲		▲	△
P	●	○	●	●	●	●	○	●	●	●	○	-	●	●	●	●	●	●	●	●	●	●
M	○	-	-	●	○	○	○	-	●	-	●	-	●	-	○	○	○	○	○	-	○	○
K	●	-	-	○	○	○	-	○	-	○	-	○	-	○	-	○	○	○	○	-	○	-
N	●	-	-	-	-	-	-	-	-	-	-	-	-	-	-	●	●	●	●	-	●	-
S	○	-	-	-	-	-	-	-	-	-	-	-	-	●	-	○	○	○	○	-	○	-
H	-	-	-	-	-	-	●	●	-	-	-	-	-	-	-	-	-	-	-	-	-	-

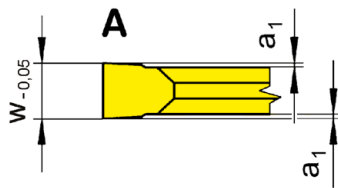
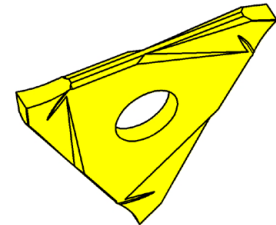
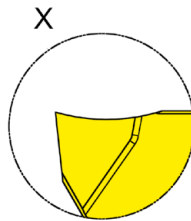
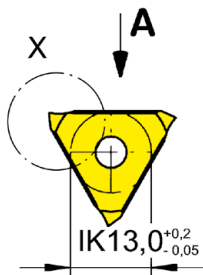
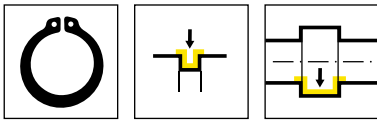

komplett geschliffen
completely ground

▲ ab Lager
on stock

HM-Sorten
Carbide grades
Δ 4 Wochen
4 weeks

Bestellnummer Part number	w	Nw	a ₁	HIS	HM-Sorten Carbide grades			
					K10	P20	EG56	TN32
312.0185.10	1,99	1,85	0,2	31201N	Δ	▲	-	▲
312.0215.10	2,29	2,15	0,2	31202N	▲	Δ	▲	-
312.0265.10	2,79	2,65	0,2	31202N	▲	▲	Δ	-
312.0315.10	3,29	3,15	0,2	31203N	▲	Δ	Δ	-
312.0415.10	4,29	4,15	0,2	31204N	▲	▲	▲	-
					P	●	●	●
					M	○	-	○
					K	●	-	○
					N	●	-	-
					S	○	-	-
					H	-	-	-



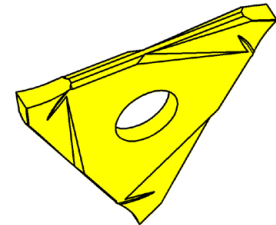
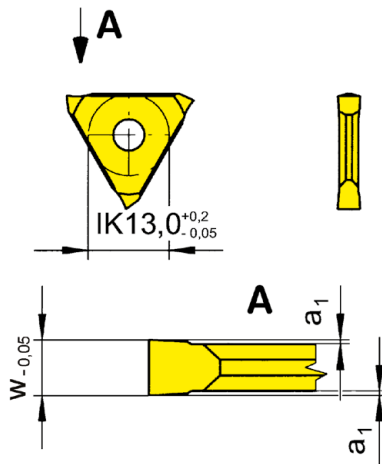
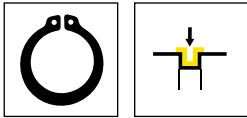

HM-Sorten
Carbide grades

▲ ab Lager
on stock

△ 4 Wochen
4 weeks

Bestellnummer Part number	w	Nw	a ₁	HIS	EG55	TN35
312.0110.80	1,24	1,1	0,2	31201N	▲	▲
312.0130.80	1,44	1,3	0,2	31201N	▲	▲
312.0160.80	1,74	1,6	0,2	31201N	▲	▲
312.0185.80	1,99	1,85	0,2	31201N	▲	▲
312.0215.80	2,29	2,15	0,2	31202N	▲	▲
312.0265.80	2,79	2,65	0,2	31202N	▲	▲
312.0315.80	3,29	3,15	0,2	31203N	△	▲
312.0415.80	4,29	4,15	0,2	31204N	▲	▲
312.0515.80	5,29	5,15	0,2	31204N	▲	▲
					P ● ●	
					M ○ ●	
					K ○ ●	
					N - ●	
					S - ●	
					H - -	

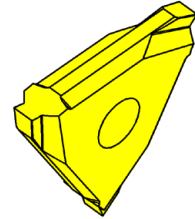
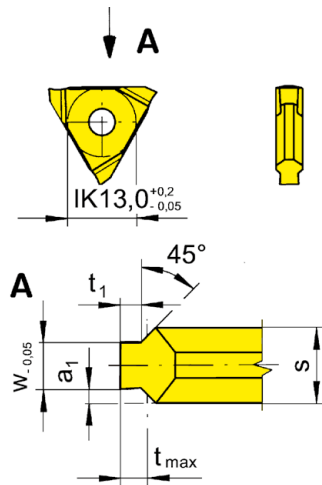
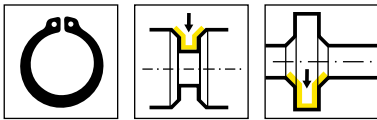

HM-Sorten
Carbide grades

▲ ab Lager
on stock

△ 4 Wochen
4 weeks

Bestellnummer Part number	w	Nw	t _{max}	a ₁	s	t ₁	HIS	HM-Sorten Carbide grades				
								P20	EG52	TN32	TN35	
312.1101.25	1,24	1,1	0,2	0,64	2,5	0,19	31202N		▲	▲		
312.1102.25	1,24	1,1	0,25	0,64	2,5	0,24	31202N		▲	▲		
312.1103.25	1,24	1,1	0,3	0,64	2,5	0,29	31202N		▲	▲		
312.1104.25	1,24	1,1	0,35	0,64	2,5	0,33	31202N		▲	▲		
312.1105.25	1,24	1,1	0,4	0,64	2,5	0,36	31202N	▲	▲	▲	▲	
312.1306.25	1,44	1,3	0,55	0,54	2,5	0,45	31202N	▲	▲	▲		
312.1607.33	1,74	1,6	0,7	0,79	3,3	0,6	31203N		▲	▲		
312.1608.33	1,74	1,6	0,85	0,79	3,3	0,75	31203N	▲	▲	▲		
312.1609.33	1,74	1,6	1	0,79	3,3	0,85	31203N		▲	▲		
312.1810.33	1,99	1,85	1	0,67	3,3	0,85	31203N		▲	▲		
312.1812.33	1,99	1,85	1,25	0,67	3,3	1,1	31203N	▲	▲	▲		
312.2115.43	2,29	2,15	1,5	1,02	4,3	1,35	31204N	▲	▲	▲		
312.2616.43	2,79	2,65	1,5	0,77	4,3	1,35	31204N	▲	▲	▲		
312.2617.43	2,79	2,65	1,75	0,77	4,3	1,6	31204N	▲	▲	▲		
312.3118.53	3,29	3,15	1,75	1,02	5,3	1,6	31204N	▲	▲	▲		
312.4120.53	4,29	4,15	2	0,52	5,3	1,85	31204N		▲	▲		
312.4125.53	4,29	4,15	2,5	0,52	5,3	2,35	31204N		▲	▲		
312.5130.63	5,29	5,15	3	0,52	6,3	2,85	31204N		▲	▲		
								P	●	●	●	●
								M	-	○	-	●
								K	-	-	-	●
								N	-	-	-	●
								S	-	-	-	●
								H	-	-	-	-



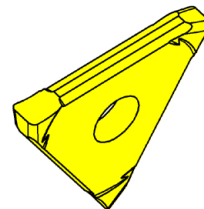
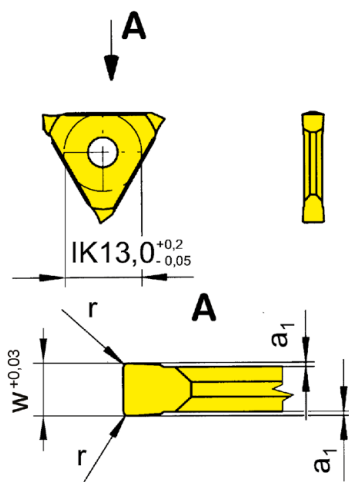
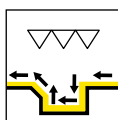

HM-Sorten
Carbide grades

▲ ab Lager
on stock

△ 4 Wochen
4 weeks

Bestellnummer Part number	w	r	a ₁	HIS	HM-Sorten										
					K10	P20	AS62	EG52	TF45	TI22	TI25	TN32	TN35	H20	
312.0100.02	1	0,2	0,1	31201N				▲				▲	▲		
312.0150.02	1,5	0,2	0,25	31201N	△	▲		▲				▲	▲	▲	
312.0200.02	2	0,2	0,25	31202N	▲	▲		▲	▲			▲	▲	▲	▲
312.0200.04	2	0,4	0,25	31202N		▲	▲	▲		▲		▲	▲	▲	▲
312.0300.02	3	0,2	0,25	31203N	△	▲		▲				▲	▲	▲	▲
312.0300.06	3	0,6	0,25	31203N		▲		▲				▲	▲	▲	▲
312.0400.02	4	0,2	0,25	31204N		▲		▲				▲	▲	▲	▲
312.0400.08	4	0,8	0,25	31204N		△		▲				▲	▲	▲	▲
312.0400.12	4	1,2	0,25	31204N		△		△				▲	▲	▲	▲
					P	●	●	●	●	●	●	●	●	●	●
					M	○	-	-	○	●	-	●	-	●	○
					K	●	-	-	-	●	-	●	-	●	-
					N	●	-	-	-	●	-	●	-	●	-
					S	○	-	-	-	●	-	●	-	●	-
					H	-	-	-	-	-	-	-	-	-	-

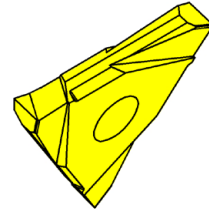
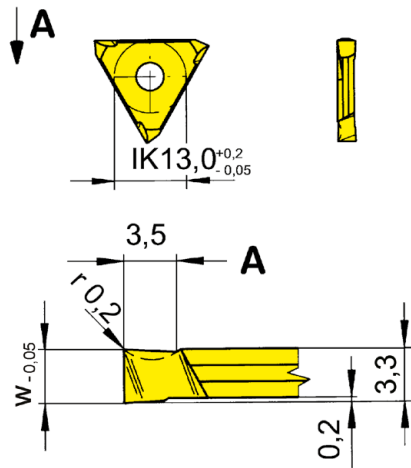
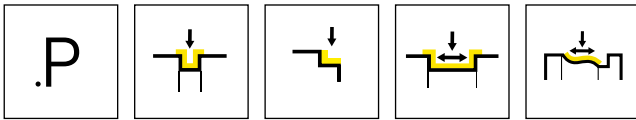

L = links wie gezeichnet
L = left hand version shown

R = rechts spiegelbildlich
R = right hand version

▲ ab Lager
on stock

HM-Sorten
Carbide grades
Δ 4 Wochen
4 weeks

Bestellnummer Part number	w	HIS	P20	EG52	TC92	TN32
R312.3031.33	3,29	31203N	▲	▲	▲	▲
L312.3031.33	3,29	31203N	Δ	▲	Δ	▲

Die besondere Schneidengeometrie erlaubt unter Beibehaltung einer geraden und rechtwinkligen Hauptschneide sowohl in radialer als auch in axialer Richtung positive Spanwinkel.
The special cutting geometry permits a positive chip breaking angle when keeping a straight and right angled cutting edge.

P	●	●	●	●
M	-	○	-	-
K	-	-	-	-
N	-	-	-	-
S	-	-	-	-
H	-	-	-	-



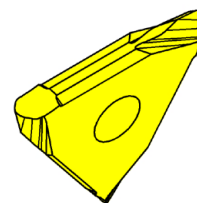
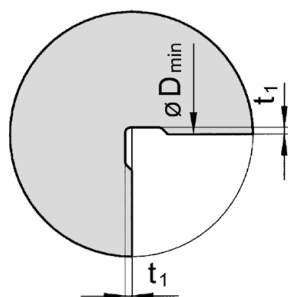
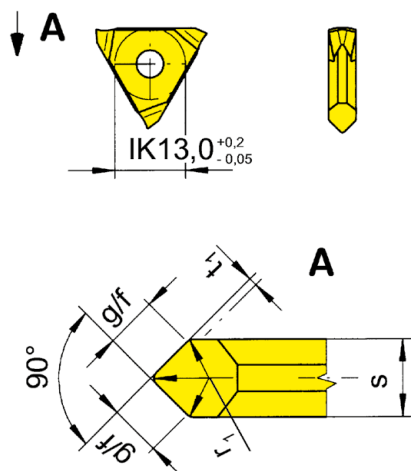
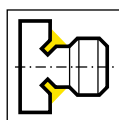

HM-Sorten
Carbide grades

▲ ab Lager
on stock

△ 4 Wochen
4 weeks

Bestellnummer Part number	D_{min}	t_1	s	g/f	r_1	HIS		P20	AS62	EG52	TC92	
312.0602.24	19	0,2	2,4	1,7	0,6	31202N		▲	▲	▲	▲	
312.0603.33	23	0,3	3,3	2,3	0,6	31203N		▲		▲		
312.1002.30	20	0,2	3	2,1	1	31203N		▲		△		
312.1004.50	29	0,4	5	3,6	1	31204N		▲		▲		
312.1603.50	25	0,3	5	3,6	1,6	31204N		△		△		
								P	●	●	●	●
								M	-	-	○	-
								K	-	-	-	-
								N	-	-	-	-
								S	-	-	-	-
								H	-	-	-	-

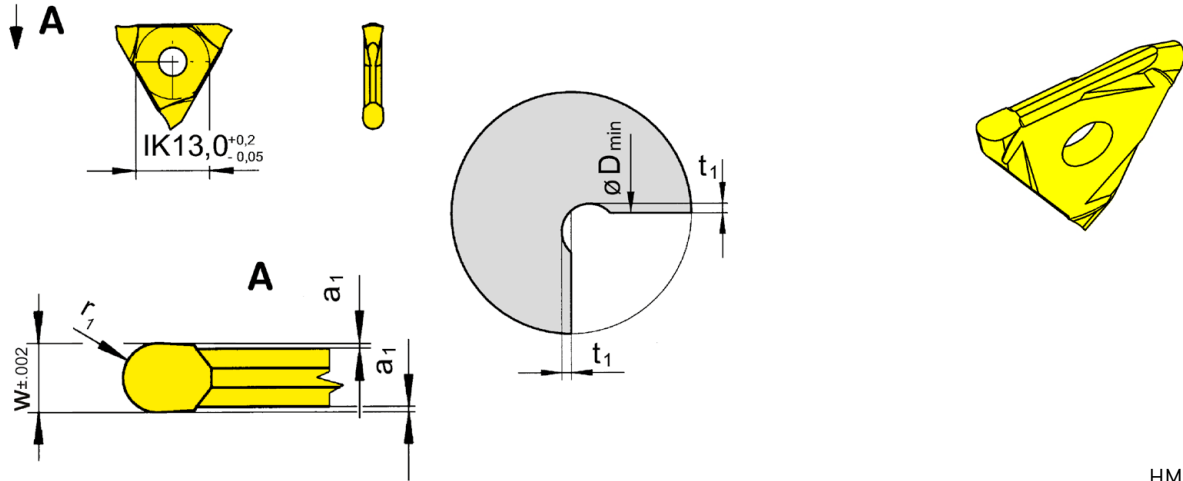
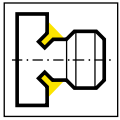

HM-Sorten
Carbide grades

▲ ab Lager
on stock

△ 4 Wochen
4 weeks

Bestellnummer Part number	w	a ₁	r ₁	D _{min}	t ₁	HIS	K10	P20	EG52	TC92	TF45	TN32	TN35
312.0010.20	2	0,2	1	22	0,7	31202N	▲	▲	▲	▲	△	▲	▲
312.0015.30	3	0,2	1,5	27	1	31202N	▲	▲	▲	▲		▲	
312.0020.40	4	0,2	2	30	1,2	31204N	▲	▲	▲	▲		▲	
312.0025.50	5	0,2	2,5	35	1,5	31204N		▲	▲	△		▲	
P	●	●	●	●	●	●	●	●	●	●	●	●	●
M	○	-	○	-	●	-	●	-	●	-	-	●	-
K	●	-	-	-	-	-	●	-	-	-	-	-	●
N	●	-	-	-	-	-	●	-	-	●	-	-	●
S	○	-	-	-	-	-	○	-	-	-	●	-	●
H	-	-	-	-	-	-	-	-	-	-	-	-	-



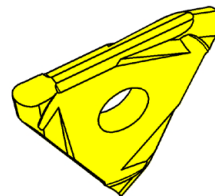
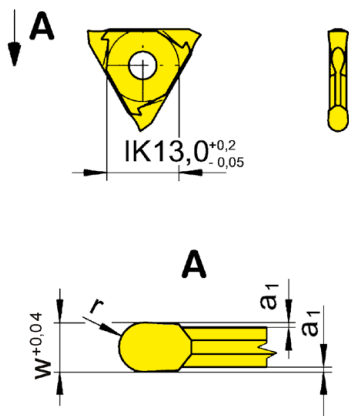
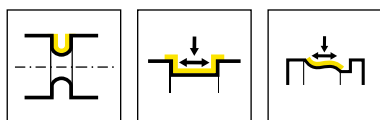

HM-Sorten
Carbide grades

▲ ab Lager
on stock

△ 4 Wochen
4 weeks

Bestellnummer Part number	w	a ₁	r	HIS	P20	AS45	EG35	EG55	TF45	TH35	TI25	TN32	TN35
					▲	▲	▲						
312.0050.02	0,5	0,07	0,25	31201N	▲	▲	▲					▲	
312.0100.05	1	0,09	0,5	31201N	▲	▲	▲			△		▲	△
312.0110.05	1,1	0,09	0,55	31201N		▲		△					
312.0120.06	1,2	0,2	0,6	31201N	▲	▲		▲				▲	
312.0140.07	1,4	0,2	0,7	31201N		▲		▲					
312.0160.08	1,6	0,25	0,8	31201N	▲	▲		▲				▲	
312.0180.09	1,8	0,25	0,9	31201N		▲		▲					
312.0200.10	2	0,25	1	31201N	▲	▲		▲	△		△	▲	
312.0220.11	2,2	0,25	1,1	31202N		▲		▲					
312.0250.12	2,5	0,25	1,25	31202N	▲	▲		△				▲	
312.0280.14	2,8	0,25	1,4	31202N		▲		△					
312.0300.15	3	0,25	1,5	31202N	▲	▲		▲				▲	
312.0360.18	3,6	0,25	1,8	31203N		▲		△					
312.0400.20	4	0,25	2	31203N	▲	▲		△				▲	
Nutbreiten bis 1,6 mm nur zum Nutenstechdrehen empfohlen Width of groove up to 1,6 mm recommend only for grooving					P	●	●	●	●	●	●	●	●
					M	-	●	○	●	●	●	-	●
					K	-	●	○	○	●	●	-	●
					N	-	○	-	●	●	●	-	●
					S	-	●	-	●	●	●	-	●
					H	-	-	-	-	-	-	-	-



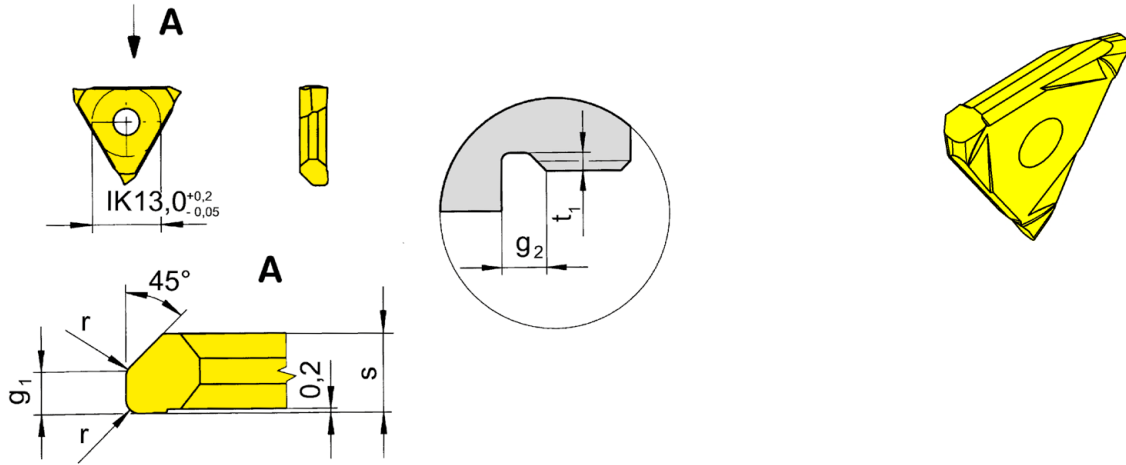
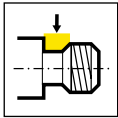

R = rechts wie gezeichnet
R = right hand version shown

L = links spiegelbildlich
L = left hand version

▲ ab Lager
on stock

HM-Sorten
Carbide grades
Δ 4 Wochen
4 weeks

Bestellnummer Part number	P	r	t ₁	s	g ₁	g ₂	HIS	P20	EG55	TN35
R312.1050.17	0,5	0,2	0,4	1,7	0,6	1	31201N • 31201R	Δ	▲	▲
R312.1060.17	0,6	0,4	0,5	1,7	0,7	1,2	31201N • 31201R	Δ	Δ	Δ
R312.1070.17	0,7	0,4	0,55	1,7	0,85	1,4	31201N • 31201R	Δ	Δ	Δ
R312.1080.27	0,8	0,4	0,65	2,7	0,95	1,6	31202N • 31202R	Δ	▲	▲
R312.1100.27	1	0,6	0,8	2,7	1,2	2	31202N • 31202R	Δ	▲	▲
R312.1125.27	1,25	0,6	1	2,7	1,5	2,5	31202N • 31202R	Δ	▲	▲
R312.1150.37	1,5	0,8	1,15	3,7	1,85	3	31203N • 31203R	Δ	▲	▲
R312.1175.37	1,75	1	1,3	3,7	2,2	3,5	31203N • 31203R	Δ	Δ	Δ
R312.1200.53	2	1	1,5	5,3	2,5	4	31204N • 31204R	▲	Δ	Δ
R312.1250.53	2,5	1,2	1,8	5,3	3,2	5	31204N • 31204R	Δ	Δ	Δ
R312.1300.63	3	1,6	2,2	6,3	3,8	6	31204N • 31204R	Δ	Δ	Δ
L312.1050.17	0,5	0,2	0,4	1,7	0,6	1	31201N • 31201L	Δ	Δ	Δ
L312.1060.17	0,6	0,4	0,5	1,7	0,7	1,2	31201N • 31201L	Δ	Δ	Δ
L312.1070.17	0,7	0,4	0,55	1,7	0,85	1,4	31201N • 31201L	Δ	Δ	Δ
L312.1080.27	0,8	0,4	0,65	2,7	0,95	1,6	31202N • 31202L	Δ	Δ	▲
L312.1100.27	1	0,6	0,8	2,7	1,2	2	31202N • 31202L	Δ	Δ	Δ
L312.1125.27	1,25	0,6	1	2,7	1,5	2,5	31202N • 31202L	Δ	Δ	▲
L312.1150.37	1,5	0,8	1,15	3,7	1,85	3	31203N • 31203L	Δ	Δ	Δ
L312.1175.37	1,75	1	1,3	3,7	2,2	3,5	31203N • 31203L	Δ	Δ	Δ
L312.1200.53	2	1	1,5	5,3	2,5	4	31204N • 31204L	Δ	Δ	Δ
L312.1250.53	2,5	1,2	1,8	5,3	3,2	5	31204N • 31204L	Δ	Δ	Δ
L312.1300.63	3	1,6	2,2	6,3	3,8	6	31204N • 31204L	Δ	Δ	Δ
P	●	●	●							
M	-	○	●							
K	-	○	●							
N	-	-	●							
S	-	-	●							
H	-	-	-							

K

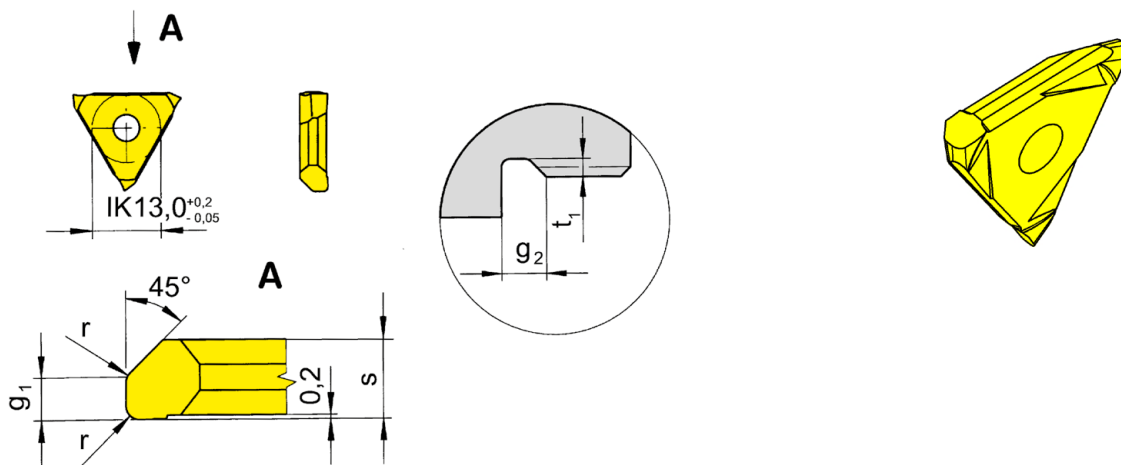
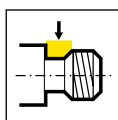

R = rechts wie gezeichnet
R = right hand version shown

L = links spiegelbildlich
L = left hand version

▲ ab Lager
on stock

HM-Sorten
Carbide grades
Δ 4 Wochen
4 weeks

Bestellnummer Part number	P	r	t ₁	s	g ₁	g ₂	HIS	P20	EG55	TN35
R312.3050.17	0,5	0,2	0,4	1,7	1,1	1,5	31201N • 31201R		Δ	Δ
R312.3060.27	0,6	0,4	0,5	2,7	1,3	1,8	31202N • 31202R	Δ	▲	▲
R312.3070.27	0,7	0,4	0,55	2,7	1,55	2,1	31202N • 31202R	Δ	Δ	Δ
R312.3080.27	0,8	0,4	0,65	2,7	1,75	2,4	31202N • 31202R	Δ	Δ	Δ
R312.3100.37	1	0,6	0,8	3,7	2,2	3	31203N • 31203R	Δ	▲	▲
R312.3125.53	1,25	0,6	1	5,3	2,8	3,8	31204N • 31204R		Δ	Δ
R312.3150.53	1,5	0,8	1,15	5,3	3,35	4,5	31204N • 31204R		▲	▲
R312.3175.56	1,75	1	1,3	5,6	4	5,3	31204N • 31204R		Δ	Δ
R312.3200.63	2	1	1,5	6,3	4,5	6	31204N • 31204R		Δ	Δ
L312.3050.17	0,5	0,2	0,4	1,7	1,1	1,5	31201N • 31201L	Δ	Δ	Δ
L312.3060.27	0,6	0,4	0,5	2,7	1,3	1,8	31202N • 31202L	Δ	▲	▲
L312.3070.27	0,7	0,4	0,55	2,7	1,55	2,1	31202N • 31202L	Δ	Δ	Δ
L312.3080.27	0,8	0,4	0,65	2,7	1,75	2,4	31202N • 31202L	Δ	Δ	Δ
L312.3100.37	1	0,6	0,8	3,7	2,2	3	31203N • 31203L	Δ	Δ	Δ
L312.3125.53	1,25	0,6	1	5,3	2,8	3,8	31204N • 31204L	Δ	Δ	Δ
L312.3150.53	1,5	0,8	1,15	5,3	3,35	4,5	31204N • 31204L	Δ	Δ	Δ
L312.3175.56	1,75	1	1,3	5,6	4	5,3	31204N • 31204L	Δ	Δ	Δ
L312.3200.63	2	1	1,5	6,3	4,5	6	31204N • 31204L	Δ	Δ	Δ
P	●	●	●							
M	-	○	●							
K	-	○	●							
N	-	-	●							
S	-	-	●							
H	-	-	-							

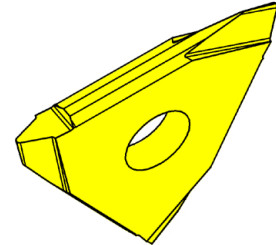
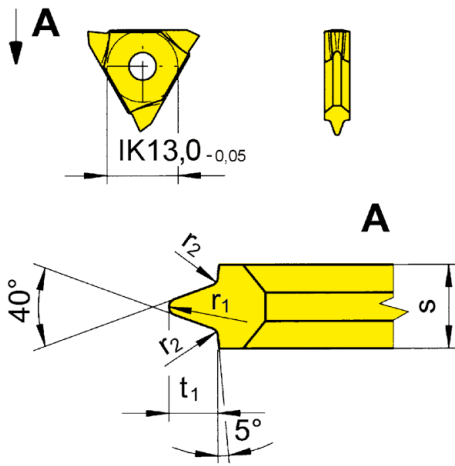
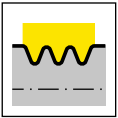

HM-Sorten
Carbide grades

▲ ab Lager
on stock

△ 4 Wochen
4 weeks

Bestellnummer Part number	r ₂	t ₁	s	r ₁	HIS	P20	EG52	TN32
312.0223.23	0,2	2,3	2,34	0,25	31202N	△	▲	△
312.0223.30	0,2	2,3	3	0,25	31203N	▲	▲	▲

WSP 312.0223.23 für Paket-Bestückung WSP 312.0223.30 für Einzel-Bestückung
Insert 312.0223.23 for multi grooving Insert 312.0223.30 for single grooving

Nutform:
Poly-V-Riemennut Profil „J“
Shape of groove:
Poly-V-belt grooves profile „J“

P	●	●	●
M	-	○	-
K	-	-	-
N	-	-	-
S	-	-	-
H	-	-	-

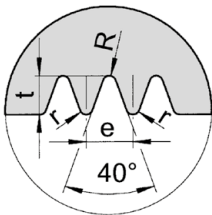

e	t		R		r
±0,25	max	min	max	min	
2,34	2,34	2,08	0,38	0,25	0,2

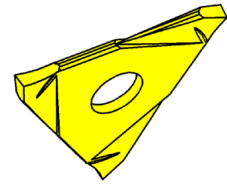
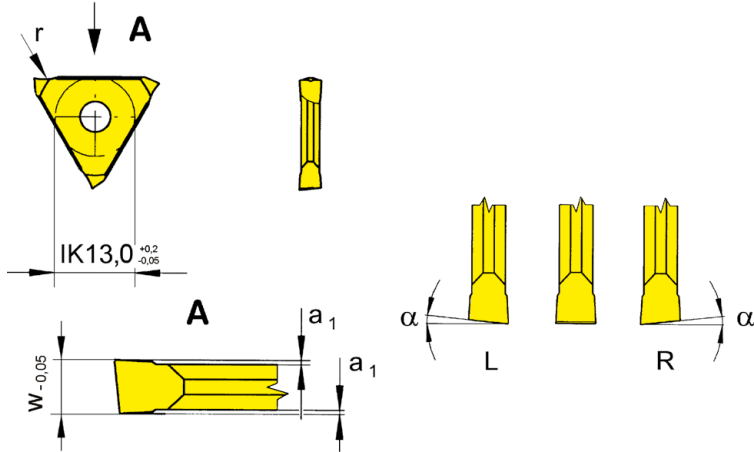
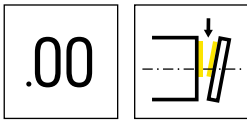

R = rechts wie gezeichnet
R = right hand version shown

L = links spiegelbildlich
L = left hand version

HM-Sorten
Carbide grades
▲ ab Lager
on stock
Δ 4 Wochen
4 weeks

Bestellnummer Part number	w	α	a ₁	HIS	EG35	TF45	TF46	TI25	TN35
R312.0614.00	1,44	6°	0,2	31201N	▲	▲	▲	▲	▲
L312.0614.00	1,44	6°	0,2	31201N	▲	▲	Δ	▲	▲
					P	●	●	●	●
					M	●	●	○	●
					K	○	●	●	●
					N	-	●	●	●
					S	-	●	○	●
					H	-	-	-	-

Abstechen von Wellen
Parting off solid bars

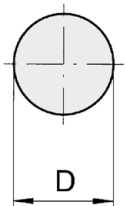

D bis/up to 11 mm

Abstechen von Rohren
Parting off tubes

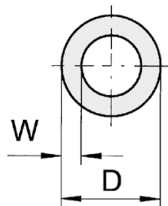

D ≥ 50 bis/up to W ≈ 5 mm
D ≤ 50 bis/up to W ≈ 4 mm

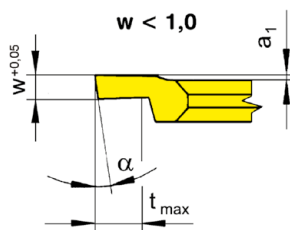
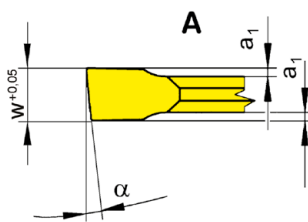
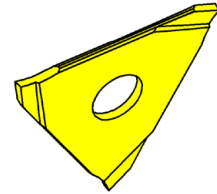
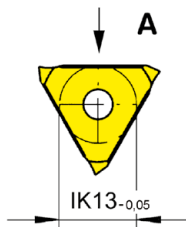
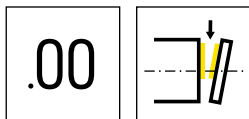

R = rechts wie gezeichnet
R = right hand version shown

L = links spiegelbildlich
L = left hand version

▲ ab Lager
on stock

HM-Sorten
Carbide grades
△ 4 Wochen
4 weeks

Bestellnummer Part number	w	t _{max}	α	a ₁	HIS	HM-Sorten Carbide grades			
						EG35	TF45	TI25	TN35
R312.0805.00	0,5	1	8°	0,1	31208N	▲	▲		
R312.0808.00	0,8	1,5	8°	0,1	31208N	▲	▲		
R312.0510.00	1	8	5°	0,1	31208N	▲	▲		
R312.1210.00	1	8	12°	0,1	31208N	▲	▲	△	▲
R312.0512.00	1,2	8	5°	0,2	31208N	▲	▲		
R312.0515.00	1,5	8	5°	0,2	31211N	▲	▲		
L312.0805.00	0,5	1	8°	0,1	31208N	▲	▲		
L312.0808.00	0,8	1,5	8°	0,1	31208N	▲	▲		
L312.0510.00	1	8	5°	0,1	31208N	▲	▲		
L312.1210.00	1	8	12°	0,1	31208N	▲	▲	△	▲
L312.0512.00	1,2	8	5°	0,2	31208N	▲	▲		
L312.0515.00	1,5	8	5°	0,2	31211N	▲	▲		
P	•	•	•	•					
M	•	•	•	•					
K	•	•	•	•					
N	-	•	•	•					
S	-	•	•	•					
H	-	-	-	-					

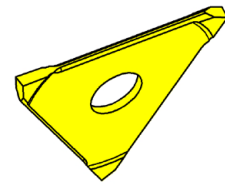
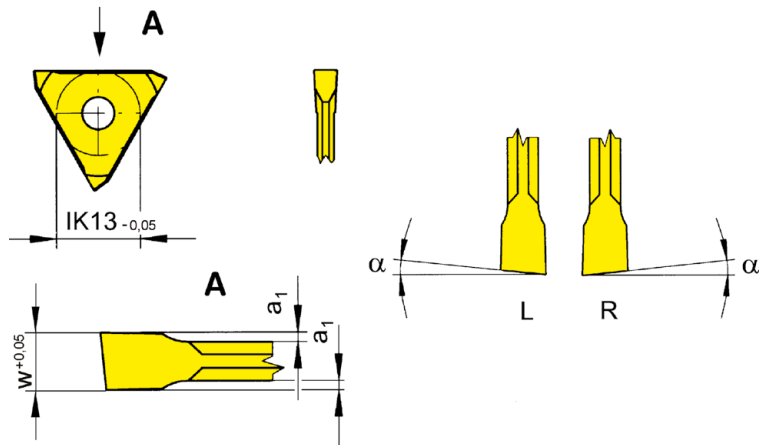
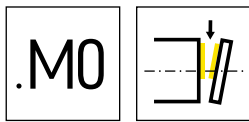

R = rechts wie gezeichnet
R = right hand version shown

L = links spiegelbildlich
L = left hand version

▲ ab Lager
on stock

HM-Sorten
Carbide grades
Δ 4 Wochen
4 weeks

Bestellnummer Part number	w	t _{max}	α	a ₁	HIS	K10	EG35	TF45
R312.0512.M0	1,2	8	5°	0,2	31208N	Δ	▲	▲
R312.0515.M0	1,5	8	5°	0,2	31211N	▲	▲	▲
L312.0512.M0	1,2	8	5°	0,2	31208N	Δ		▲
L312.0515.M0	1,5	8	5°	0,2	31211N	Δ	Δ	▲
P	●	●	●					
M	○	●	●					
K	●	○	●					
N	●	-	●					
S	○	-	●					
H	-	-	-					

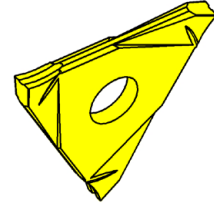
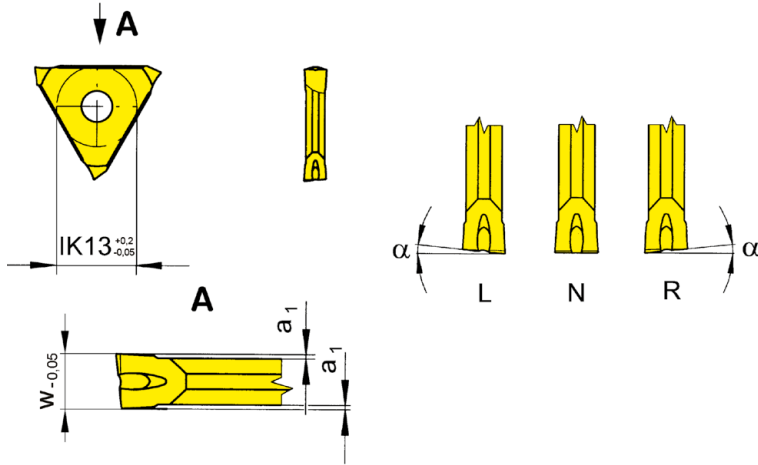
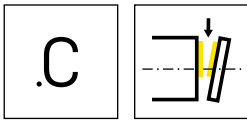

R = rechts wie gezeichnet
R = right hand version shown

L = links spiegelbildlich
L = left hand version

HM-Sorten
Carbide grades
▲ ab Lager
on stock
△ 4 Wochen
4 weeks

Bestellnummer Part number	w	α	a ₁	HIS	MG12	P20	EG55	TC92	TF45	TN32	TN35
					R312.0514.00	1,44	5°	0,2	31201N • 31202N • 31201R • 31202R		▲
R312.0518.00	1,99	5°	0,2	31202N • 31202R		▲	▲	▲		▲	▲
R312.0521.00	2,29	5°	0,2	31202N • 31202R	▲	▲	▲	▲		▲	▲
L312.0514.00	1,44	5°	0,2	31201N • 31202N • 31201R • 31202R		▲	▲		▲		
L312.0518.00	1,99	5°	0,2	31202N • 31202R		▲	▲	▲		▲	▲
L312.0521.00	2,29	5°	0,2	31202N • 31202R	▲	▲	▲	▲		▲	▲
N312.0014.00	1,44	0°	0,2	31202N			▲	▲	▲		
N312.0018.00	1,99	0°	0,2	31202N			▲	▲	▲	▲	▲
N312.0021.00	2,29	0°	0,2	31202N		▲	▲	▲			▲
					P	o	o	o	o	o	o
					M	-	-	o	-	o	-
					K	-	-	o	-	o	-
					N	-	-	-	-	o	-
					S	-	-	-	-	o	-
					H	-	-	-	-	-	-

Abstechen von Wellen
Parting off solid bars

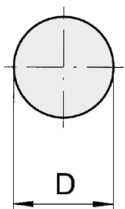

D bis/up to 10 mm

Abstechen von Rohren
Parting off tubes

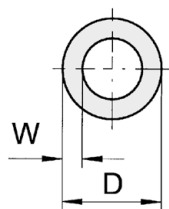

D ≥ 50 bis/up to W ≈ 5 mm
D ≤ 50 bis/up to W ≈ 4 mm

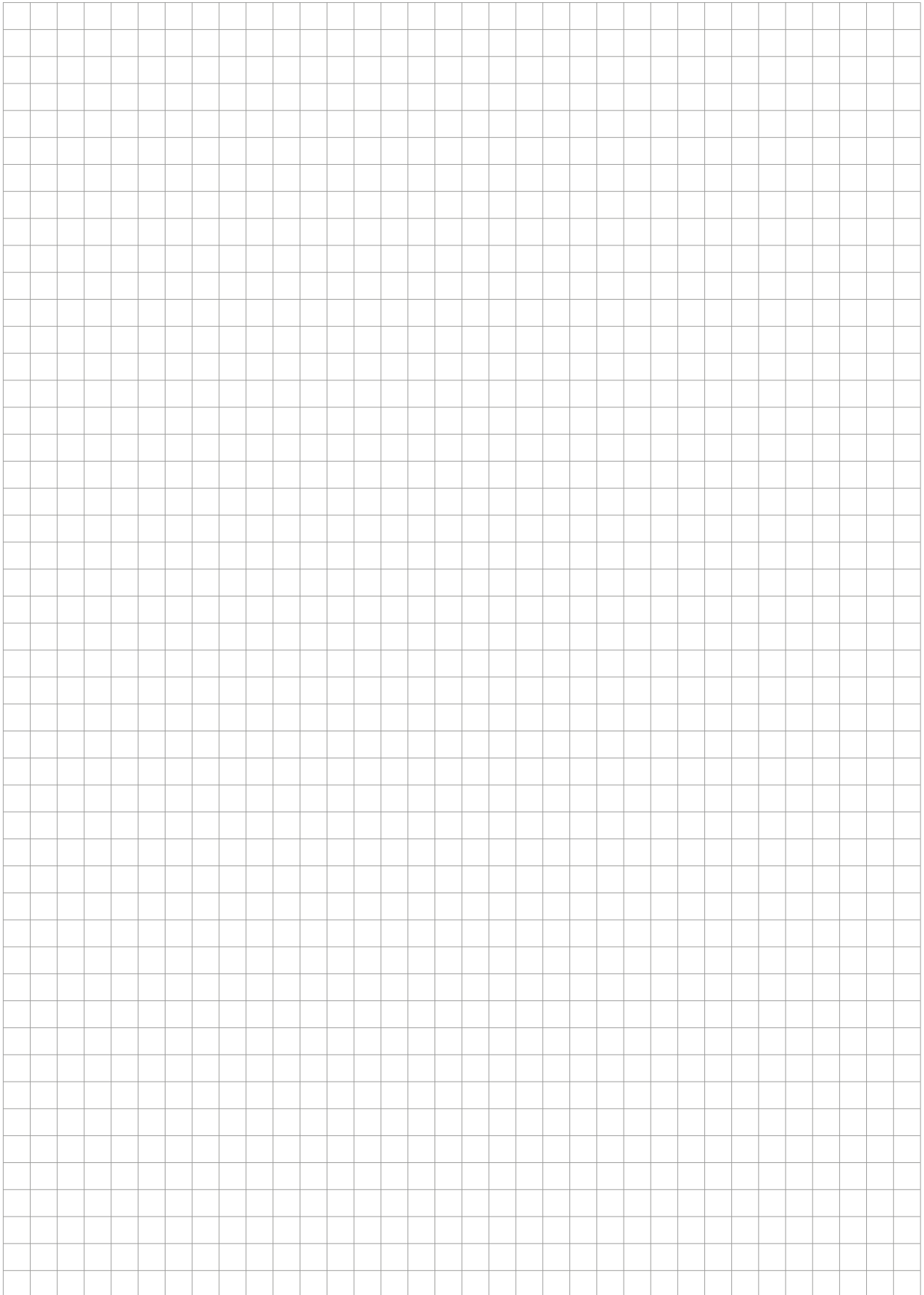

K

S32T



**Klemmhalter und
Schneidplatten**

**Toolholder and
Inserts**

Geometrien und
Vorschübe
Geometries and feed rates

Seite/Page
539

Klemmhalter
Toolholder
H32T

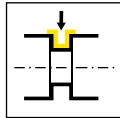

Seite/Page
540

Wendeschneidplatte
Indexable insert
S32T

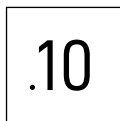

Seite/Page
541-542

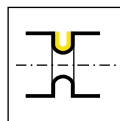

Seite/Page
543

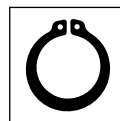

Seite/Page
544

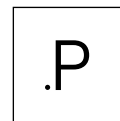

Seite/Page
545

Geometrie Geometry	Werkstoff Material	Vorschubbereich f [mm/U] Feed rate f [mm/rev]	Bearbeitung Machining						
.10	<table border="1"> <tr> <td>P</td> <td>M</td> <td>K</td> </tr> <tr> <td>N</td> <td>S</td> <td>H</td> </tr> </table>	P	M	K	N	S	H	↓ 0,05-0,15	
P	M	K							
N	S	H							
.P	<table border="1"> <tr> <td>P</td> <td>M</td> <td>K</td> </tr> <tr> <td>N</td> <td>S</td> <td>H</td> </tr> </table>	P	M	K	N	S	H	↓ 0,02-0,08 ↔ 0,02-0,04	
P	M	K							
N	S	H							



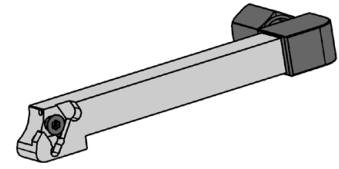
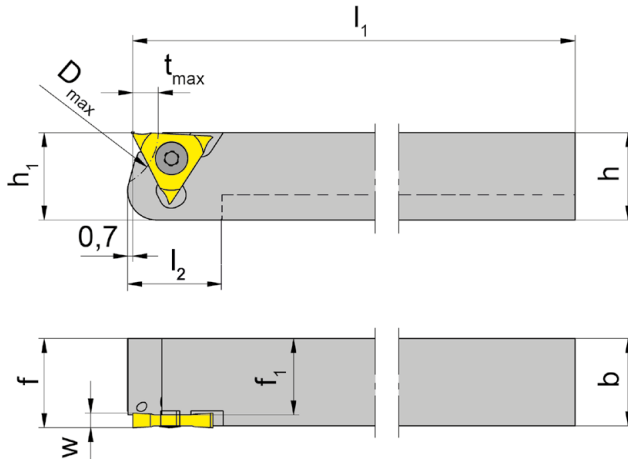
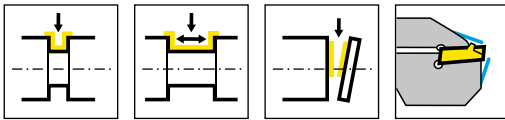

R = rechts wie gezeichnet
R = right hand version shown

L = links spiegelbildlich
L = left hand version

Bestellnummer Part number	h	b	l ₁	l ₂	h ₁	f ₁	f	D _{max}	t _{max}	HWS
RH32T.0808.6.10.IK	8	8	100	13	8	6,5	f ₁ +s ₁	15,5	3,5	32T01N • 32T01R
RH32T.0808.6.20.IK	8	8	100	13	8	6	f ₁ +s ₁	15,5	3,5	32T02N • 32T02R
RH32T.1010.6.10.IK	10	10	100	-	10	8,5	f ₁ +s ₁	15,5	3,5	32T01N • 32T01R
RH32T.1010.6.20.IK	10	10	100	-	10	8	f ₁ +s ₁	15,5	3,5	32T02N • 32T02R
RH32T.1212.6.10.IK	12	12	100	-	12	10,5	f ₁ +s ₁	15,5	3,5	32T01N • 32T01R
RH32T.1212.6.20.IK	12	12	100	-	12	10	f ₁ +s ₁	15,5	3,5	32T02N • 32T02R
RH32T.1616.6.10.IK	16	16	125	-	16	14,5	f ₁ +s ₁	15,5	3,5	32T01N • 32T01R
RH32T.1616.6.20.IK	16	16	125	-	16	14	f ₁ +s ₁	15,5	3,5	32T02N • 32T02R
LH32T.0808.6.10.IK	8	8	100	13	8	6,5	f ₁ +s ₁	15,5	3,5	32T01N • 32T01L
LH32T.0808.6.20.IK	8	8	100	13	8	6	f ₁ +s ₁	15,5	3,5	32T02N • 32T02L
LH32T.1010.6.10.IK	10	10	100	-	10	8,5	f ₁ +s ₁	15,5	3,5	32T01N • 32T01L
LH32T.1010.6.20.IK	10	10	100	-	10	8	f ₁ +s ₁	15,5	3,5	32T02N • 32T02L
LH32T.1212.6.10.IK	12	12	100	-	12	10,5	f ₁ +s ₁	15,5	3,5	32T01N • 32T01L
LH32T.1212.6.20.IK	12	12	100	-	12	10	f ₁ +s ₁	15,5	3,5	32T02N • 32T02L
LH32T.1616.6.10.IK	16	16	125	-	16	14,5	f ₁ +s ₁	15,5	3,5	32T01N • 32T01L
LH32T.1616.6.20.IK	16	16	125	-	16	14	f ₁ +s ₁	15,5	3,5	32T02N • 32T02L

w, s1 siehe WSP
w, s1 see indexable inserts

Bei Schaftabmessung 8 x 8 mm, Klemmhalter mit Absetzung am Kopf.
For shank dimension 8 x 8 mm toolholder with offset at the head.

Ersatzteile

Spare Parts

Klemmhalter Toolholder	Spannschraube Clamping Screw	TORX PLUS®-Schlüssel TORX PLUS® Wrench	Kühlmittelanschluss Coolant supply	Verschlusschraube Screw Plug
R/LH32T.0808.6...	030.2507.T7P	T7PL		
R/LH32T...	030.2507.T7P	T7PL	004.00.22	
R/LH32T.1616.6...	030.2507.T7P	T7PL	004.00.16	18.908

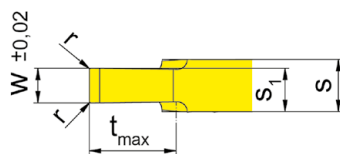
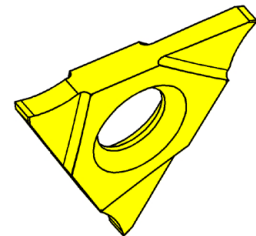
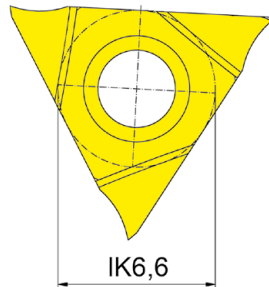
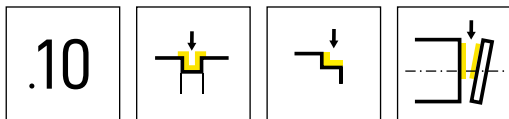

HM-Sorten
Carbide grades

▲ ab Lager
on stock

△ 4 Wochen
4 weeks

Bestellnummer Part number	w	r	s	s ₁	t _{max}	HIS	EG35	EG55
S32T.0050.00	0,5	0,05	1,5	1	1,5	32T01N	▲	
S32T.0070.00	0,7	0,05	1,5	1,1	2	32T01N	▲	
S32T.0080.00	0,8	0,05	1,5	1,15	2,5	32T01N	▲	
S32T.0100.00	1	0,05	1,5	1,25	2,5	32T01N		▲
S32T.0120.00	1,2	0,05	1,5	1,35	2,5	32T01N		▲
S32T.0150.00	1,5	0,05	1,5	1,5	2,5	32T01N		▲
S32T.0200.00	2	0,05	1,5	1,75	3,5	32T01N		▲
S32T.0250.00	2,5	0,05	2	2,25	3,5	32T02N		▲
							P ● ●	
							M ● ○	
							K ○ ○	
							N - -	
							S - -	
							H - -	



.10

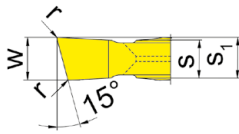
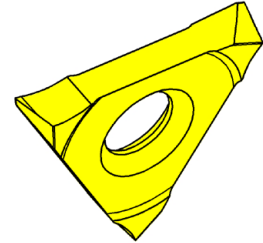
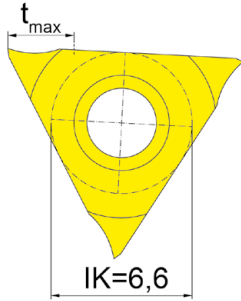
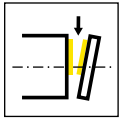

R = rechts wie gezeichnet
R = right hand version shown

L = links spiegelbildlich
L = left hand version

▲ ab Lager
on stock

HM-Sorten
Carbide grades
Δ 4 Wochen
4 weeks

Bestellnummer Part number	w	r	s	s ₁	t _{max}	HIS	EG55
RS32T.1520.10	2	0,05	1,5	1,75	3,5	32T01N	▲
LS32T.1520.10	2	0,05	1,5	1,75	3,5	32T01N	▲
							P ●
							M ○
							K ○
							N -
							S -
							H -

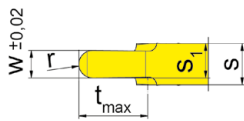
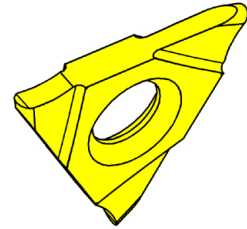
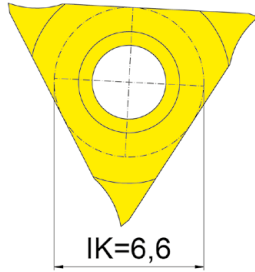
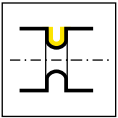

HM-Sorten
Carbide grades

▲ ab Lager
on stock

△ 4 Wochen
4 weeks

Bestellnummer Part number	w	s	s ₁	t _{max}	r	HIS	HM-Sorten Carbide grades	
							EG35	EG55
S32T.0050.25	0,5	1,5	1	1,5	0,25	32T01N	▲	
S32T.0100.50	1	1,5	1,25	2,5	0,5	32T01N		▲
S32T.0200.10	2	1,5	1,75	3,5	1	32T01N		▲
							P	● ●
							M	● ○
							K	○ ○
							N	- -
							S	- -
							H	- -



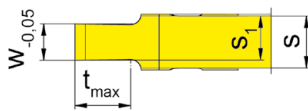
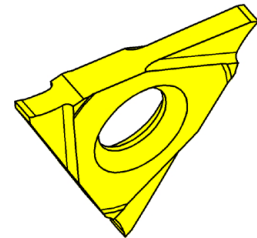
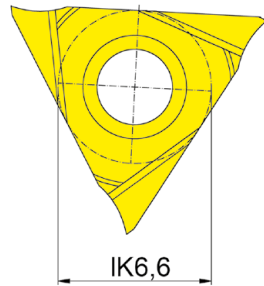
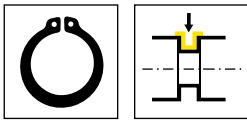

HM-Sorten
Carbide grades

▲ ab Lager
on stock

△ 4 Wochen
4 weeks

Bestellnummer Part number	w	Nw	s	s_1	t_{max}	HIS	EG35	EG55
S32T.0034.01.00	0,41	0,34	1,5	0,94	0,6	32T01N	△	
S32T.0044.01.00	0,51	0,44	1,5	0,99	0,7	32T01N	△	
S32T.0050.01.00	0,57	0,5	1,5	1,02	0,7	32T01N	▲	
S32T.0060.01.00	0,67	0,6	1,5	1,07	0,8	32T01N	▲	
S32T.0070.01.00	0,77	0,7	1,5	1,12	1,1	32T01N	▲	
S32T.0080.01.00	0,87	0,8	1,5	1,17	1,2	32T01N	▲	
S32T.0090.01.00	0,97	0,9	1,5	1,22	1,4	32T01N	▲	
S32T.0100.01.00	1,07	1	1,5	1,27	1,6	32T01N		▲
S32T.0110.01.00	1,24	1,1	1,5	1,36	1,6	32T01N		▲
S32T.0130.01.00	1,44	1,3	1,5	1,46	2	32T01N		▲
S32T.0160.01.00	1,74	1,6	1,5	1,61	3	32T01N		▲
S32T.0185.01.00	1,99	1,85	1,5	1,73	3	32T01N		▲
S32T.0215.01.00	2,29	2,15	2	2,13	3	32T02N		▲
							P ● ●	
							M ● ○	
							K ○ ○	
							N - -	
							S - -	
							H - -	

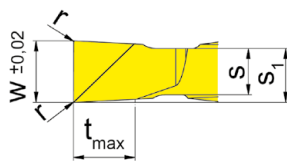
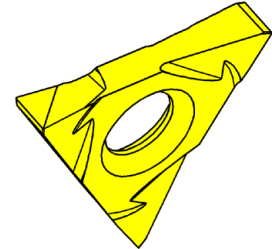
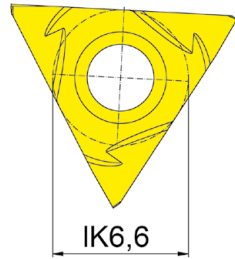
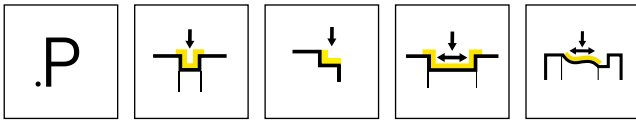

R = rechts wie gezeichnet
R = right hand version shown

L = links spiegelbildlich
L = left hand version

▲ ab Lager
on stock

HM-Sorten
Carbide grades
Δ 4 Wochen
4 weeks

Bestellnummer Part number	w	r	s	s ₁	t _{max}	HIS	EG55
RS32T.0150.P0	1,5	0,05	1,5	1,7	2	32T01R	▲
RS32T.0200.P0	2	0,05	1,5	1,75	2	32T01R	▲
RS32T.0250.P0	2,5	0,1	2	2,25	2	32T02R	▲
LS32T.0150.P0	1,5	0,05	1,5	1,7	2	32T01L	▲
LS32T.0200.P0	2	0,05	1,5	1,75	2	32T01L	▲
LS32T.0250.P0	2,5	0,1	2	2,25	2	32T02L	▲

P	●
M	○
K	○
N	-
S	-
H	-



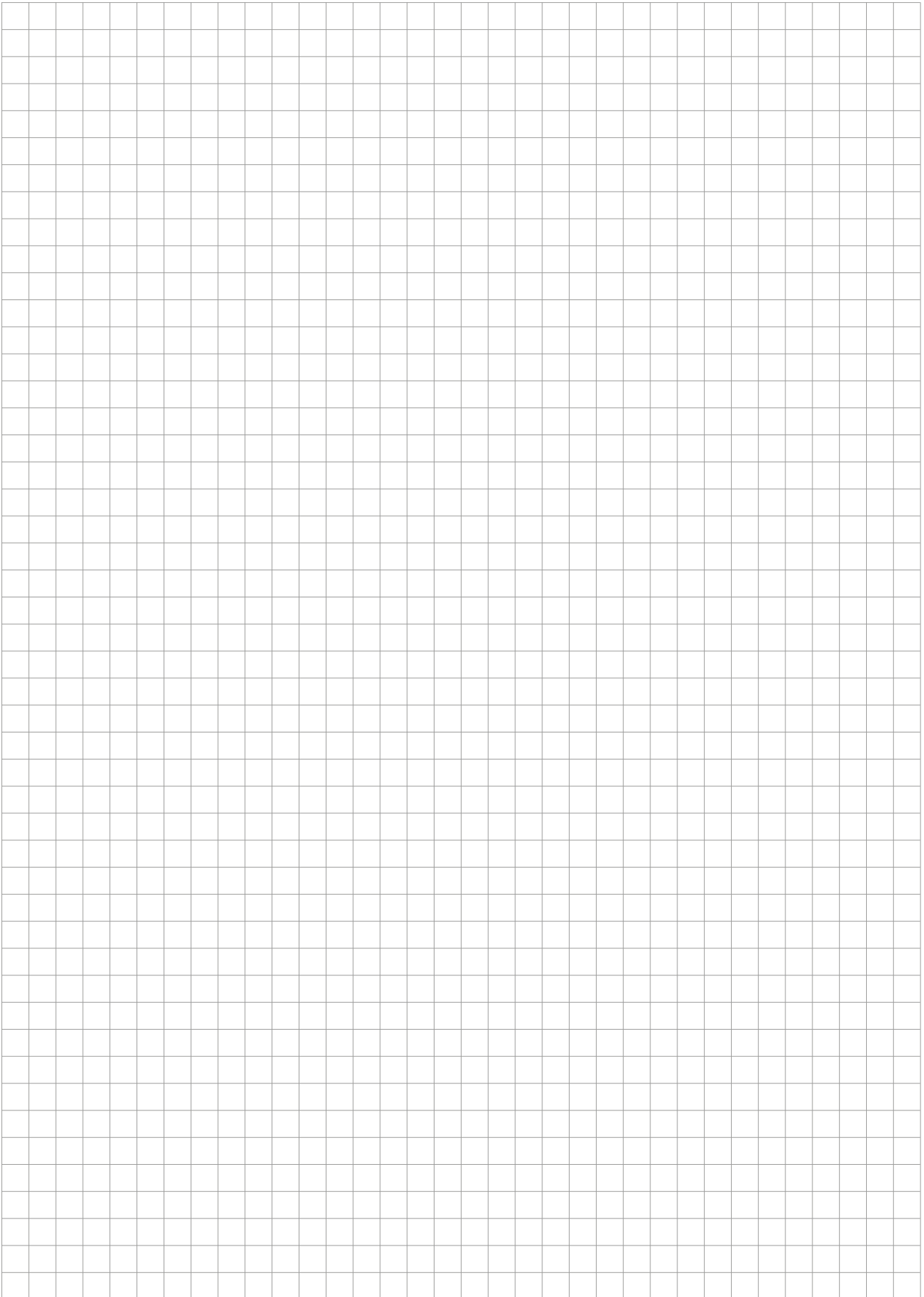

S34T



**Klemmhalter und
Schneidplatten**

**Toolholder and
Inserts**

Geometrien und
Vorschübe
Geometries and feed rates

Seite/Page
549

Klemmhalter
Toolholder
H34T

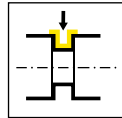

Seite/Page
550-552

Wendeschneidplatte
Indexable insert
S34T

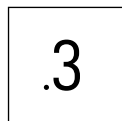

Seite/Page
553

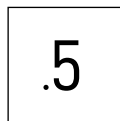

Seite/Page
554

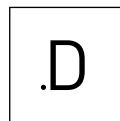

Seite/Page
555

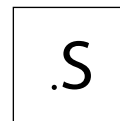

Seite/Page
556

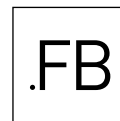

Seite/Page
557

Geometrien und Vorschübe

Geometries and feed rates



Geometrie Geometry	Werkstoff Material	Vorschubbereich f [mm/U] Feed rate f [mm/rev]	Bearbeitung Machining						
.3	<table border="1"> <tr> <td>P</td> <td>M</td> <td>K</td> </tr> <tr> <td>N</td> <td>S</td> <td>H</td> </tr> </table>	P	M	K	N	S	H	↓ 0,15-0,25 ↔ 0,15-0,40	
		P	M	K					
N	S	H							
.5	<table border="1"> <tr> <td>P</td> <td>M</td> <td>K</td> </tr> <tr> <td>N</td> <td>S</td> <td>H</td> </tr> </table>	P	M	K	N	S	H	↓ 0,10-0,45 ↔ 0,15-0,60	
		P	M	K					
N	S	H							
.D	<table border="1"> <tr> <td>P</td> <td>M</td> <td>K</td> </tr> <tr> <td>N</td> <td>S</td> <td>H</td> </tr> </table>	P	M	K	N	S	H	↓ 0,03-0,15 ↔ 0,05-0,20	
		P	M	K					
N	S	H							
.S	<table border="1"> <tr> <td>P</td> <td>M</td> <td>K</td> </tr> <tr> <td>N</td> <td>S</td> <td>H</td> </tr> </table>	P	M	K	N	S	H	↓ 0,02-0,08	
		P	M	K					
N	S	H							
.FB	<table border="1"> <tr> <td>P</td> <td>M</td> <td>K</td> </tr> <tr> <td>N</td> <td>S</td> <td>H</td> </tr> </table>	P	M	K	N	S	H	↓ 0,02-0,10 ↔ 0,0015-0,07	
		P	M	K					
N	S	H							

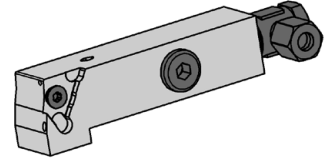
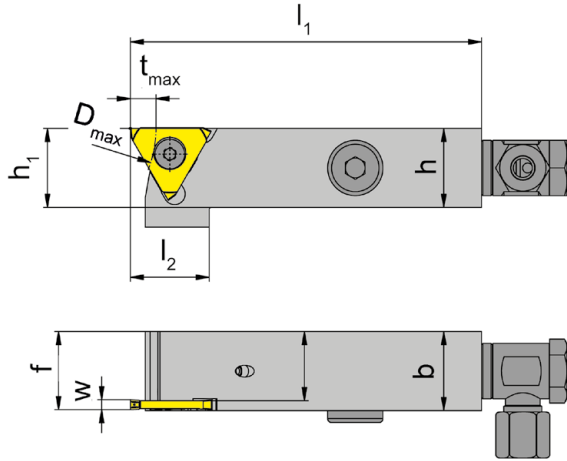
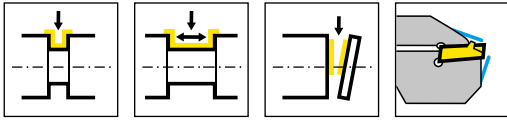

Bestellnummer Part number	h	b	l ₁	l ₂	h ₁	f ₁	f	D _{max}	t _{max}	HWS
RH34T.1212.6.00.IK	12	12	74	20	21	11,2	f ₁ +w-a ₁	60	6,5	34T00R
RH34T.1616.6.00.IK	16	16	74	20	21	15,2	f ₁ +w-a ₁	60	6,5	34T00R
RH34T.2020.4.00.IK	20	20	89	20	20	19,1	f ₁ +w-a ₁	60	6,5	34T00R
RH34T.2020.6.00.IK	20	20	89	20	25	19,2	f ₁ +w-a ₁	60	6,5	34T00R
LH34T.1212.6.00.IK	12	12	74	20	21	11,2	f ₁ +w-a ₁	60	6,5	34T00L
LH34T.1616.6.00.IK	16	16	74	20	21	15,2	f ₁ +w-a ₁	60	6,5	34T00L
LH34T.2020.4.00.IK	20	20	89	20	20	19,1	f ₁ +w-a ₁	60	6,5	34T00L
LH34T.2020.6.00.IK	20	20	89	20	25	19,2	f ₁ +w-a ₁	60	6,5	34T00L

Hinweis:

...6.00.IK = Kühlmittelzufuhr über Verschraubung

...4.00.IK = Kühlmittelzufuhr über Langloch VDI

Note:

...6.00.IK = Coolant through coolant supply

...4.00.IK = Coolant through slotted hole VDI

Ersatzteile

Spare Parts

Klemmhalter Toolholder	Kühlmittelanschluss Coolant supply	Spannschraube Clamping Screw	TORX PLUS®-Schlüssel TORX PLUS® Wrench	Verschlusschraube Screw Plug
R/LH34T.1212.6.00.IK	004.00.22	030.4093.T15P	T15PQ	
R/LH34T...	004.00.16	030.4093.T15P	T15PQ	004.00.26
R/LH34T.2020.4.00.IK		030.4093.T15P	T15PQ	

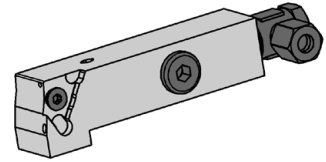
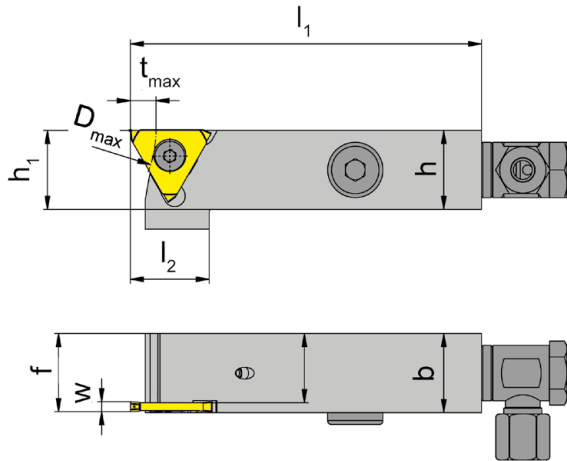
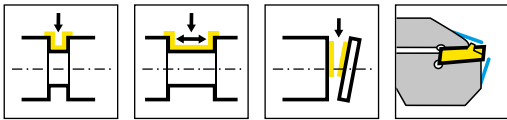

R = rechts wie gezeichnet
R = right hand version shown

L = links spiegelbildlich
L = left hand version

Bestellnummer Part number	h	b	l ₁	l ₂	h ₁	f ₁	f	D _{max}	t _{max}	HWS
RH34T.1212.6.10.IK	12	12	74	20	21	10,5	f ₁ +w-a ₁	60	6,5	34T01N
RH34T.1212.6.20.IK	12	12	74	20	21	11,76	f ₁ +w-a ₁	60	6,5	34T02N
RH34T.1212.6.30.IK	12	12	74	19	21	12,26	f ₁ +w-a ₁	60	6,5	34T03N
RH34T.1616.6.10.IK	16	16	74	20	21	14,5	f ₁ +w-a ₁	60	6,5	34T01N
RH34T.1616.6.20.IK	16	16	74	20	21	13,5	f ₁ +w-a ₁	60	6,5	34T02N
RH34T.1616.6.30.IK	16	16	74	19	21	12,5	f ₁ +w-a ₁	60	6,5	34T03N
RH34T.1616.6.40.IK	16	16	74	19	21	11,5	f ₁ +w-a ₁	60	6,5	34T04N
RH34T.2020.6.10.IK	20	20	89	20	25	18,5	f ₁ +w-a ₁	60	6,5	34T01N
RH34T.2020.6.20.IK	20	20	89	20	25	17,5	f ₁ +w-a ₁	60	6,5	34T02N
RH34T.2020.6.30.IK	20	20	89	19	25	16,5	f ₁ +w-a ₁	60	6,5	34T03N
RH34T.2020.6.40.IK	20	20	89	19	25	15,5	f ₁ +w-a ₁	60	6,5	34T04N
LH34T.1212.6.10.IK	12	12	74	20	21	10,5	f ₁ +w-a ₁	60	6,5	34T01N
LH34T.1212.6.20.IK	12	12	74	20	21	11,76	f ₁ +w-a ₁	60	6,5	34T02N
LH34T.1212.6.30.IK	12	12	74	19	21	12,26	f ₁ +w-a ₁	60	6,5	34T03N
LH34T.1616.6.10.IK	16	16	74	20	21	14,5	f ₁ +w-a ₁	60	6,5	34T01N
LH34T.1616.6.20.IK	16	16	74	20	21	13,5	f ₁ +w-a ₁	60	6,5	34T02N
LH34T.1616.6.30.IK	16	16	74	19	21	12,5	f ₁ +w-a ₁	60	6,5	34T03N
LH34T.1616.6.40.IK	16	16	74	19	21	11,5	f ₁ +w-a ₁	60	6,5	34T04N
LH34T.2020.6.10.IK	20	20	89	20	25	18,5	f ₁ +w-a ₁	60	6,5	34T01N
LH34T.2020.6.20.IK	20	20	89	20	25	17,5	f ₁ +w-a ₁	60	6,5	34T02N
LH34T.2020.6.30.IK	20	20	89	19	25	16,5	f ₁ +w-a ₁	60	6,5	34T03N
LH34T.2020.6.40.IK	20	20	89	19	25	15,5	f ₁ +w-a ₁	60	6,5	34T04N

w siehe WSP
w see indexable inserts

Ersatzteile

Spare Parts

Klemmhalter Toolholder	Kühlmittelanschluss Coolant supply	Spannschraube Clamping Screw	TORX PLUS®-Schlüssel TORX PLUS® Wrench	Verschlusschraube Screw Plug
R/LH34T.1212.6.10.IK	004.00.61	030.4093.T15P	T15PQ	
R/LH34T.1212.6.20.IK	004.00.61	030.4010.T15P	T15PQ	
R/LH34T.1212.6.30.IK	004.00.61	030.5012.T15P	T15PQ	
R/LH34T...10/...20.IK	004.00.16	030.4093.T15P	T15PQ	004.00.26
R/LH34T.1616.6.20.IK	004.00.16	030.4010.T15P	T15PQ	004.00.26
R/LH34T...30/...40.IK	004.00.16	030.5012.T15P	T15PQ	004.00.26

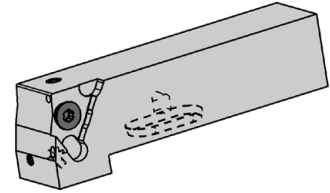
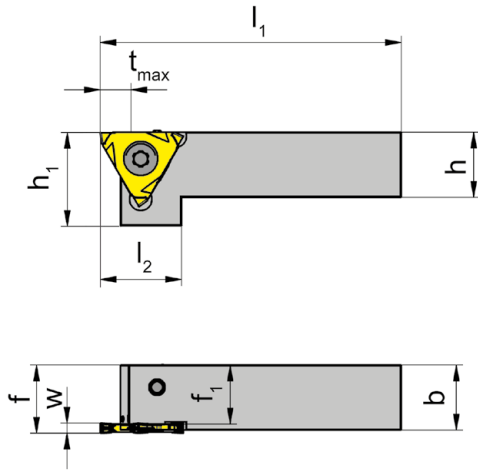
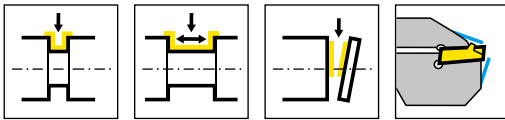

R = rechts wie gezeichnet
R = right hand version shown

L = links spiegelbildlich
L = left hand version

Bestellnummer Part number	h	b	l ₁	l ₂	h ₁	f ₁	f	D _{max}	t _{max}	HWS
RH34T.1616.4.10.IK	16	16	74	20	21	14,5	f ₁ +w-a ₁	60	6,5	34T01N
RH34T.1616.4.20.IK	16	16	74	20	21	13,5	f ₁ +w-a ₁	60	6,5	34T02N
RH34T.2020.4.10.IK	20	20	89	20	25	18,5	f ₁ +w-a ₁	60	6,5	34T01N
RH34T.2020.4.20.IK	20	20	89	20	25	17,5	f ₁ +w-a ₁	60	6,5	34T02N
RH34T.2020.4.30.IK	20	20	89	21	25	16,5	f ₁ +w-a ₁	60	6,5	34T03N
RH34T.2020.4.40.IK	20	20	89	21	25	15,5	f ₁ +w-a ₁	60	6,5	34T04N
RH34T.2525.4.10.IK	25	25	99	20	30	23,5	f ₁ +w-a ₁	60	6,5	34T01N
RH34T.2525.4.20.IK	25	25	99	20	30	22,5	f ₁ +w-a ₁	60	6,5	34T02N
RH34T.2525.4.30.IK	25	25	99	21	30	21,5	f ₁ +w-a ₁	60	6,5	34T03N
RH34T.2525.4.40.IK	25	25	99	21	30	20,5	f ₁ +w-a ₁	60	6,5	34T04N
LH34T.1616.4.10.IK	16	16	74	20	21	14,5	f ₁ +w-a ₁	60	6,5	34T01N
LH34T.1616.4.20.IK	16	16	74	20	21	13,5	f ₁ +w-a ₁	60	6,5	34T02N
LH34T.2020.4.00.IK	20	20	89	20	20	19,1	f ₁ +w-a ₁	60	6,5	34T00L
LH34T.2020.4.10.IK	20	20	89	20	25	18,5	f ₁ +w-a ₁	60	6,5	34T01N
LH34T.2020.4.20.IK	20	20	89	20	25	17,5	f ₁ +w-a ₁	60	6,5	34T02N
LH34T.2020.4.30.IK	20	20	89	21	25	16,5	f ₁ +w-a ₁	60	6,5	34T03N
LH34T.2020.4.40.IK	20	20	89	21	25	15,5	f ₁ +w-a ₁	60	6,5	34T04N
LH34T.2525.4.10.IK	25	25	99	20	30	23,5	f ₁ +w-a ₁	60	6,5	34T01N
LH34T.2525.4.20.IK	25	25	99	20	30	22,5	f ₁ +w-a ₁	60	6,5	34T02N
LH34T.2525.4.30.IK	25	25	99	21	30	21,5	f ₁ +w-a ₁	60	6,5	34T03N
LH34T.2525.4.40.IK	25	25	99	21	30	20,5	f ₁ +w-a ₁	60	6,5	34T04N

w siehe WSP
w see indexable inserts

Ersatzteile

Spare Parts

Klemmhalter Toolholder	Spannschraube Clamping Screw	TORX PLUS®-Schlüssel TORX PLUS® Wrench
R/LH34T...	030.4093.T15P	T15PQ
R/LH34T...20.IK	030.4010.T15P	T15PQ
R/LH34T...30.IK	030.5012.T15P	T15PQ
R/LH34T...40.IK	030.5012.T15P	T20PQ

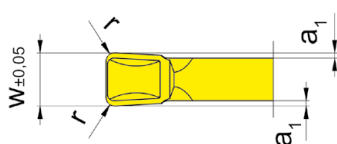
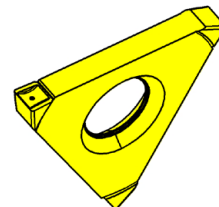
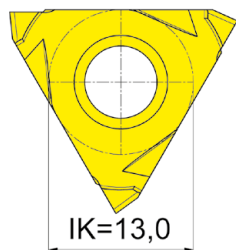
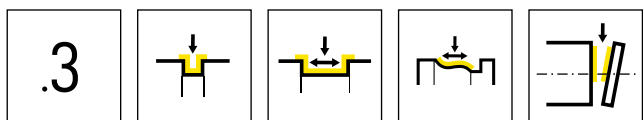

HM-Sorten
Carbide grades

▲ ab Lager
on stock

△ 4 Wochen
4 weeks

Bestellnummer Part number	w	r	a ₁	HIS	HM-Sorten	
					AS45	EG55
S34T.0200.32	2	0,2	0,25	34T01N	▲	▲
S34T.0200.34	2	0,4	0,25	34T01N	▲	▲
S34T.0250.32	2,5	0,2	0,25	34T02N	△	▲
S34T.0250.34	2,5	0,4	0,25	34T02N	△	▲
S34T.0300.32	3	0,2	0,25	34T02N	△	▲
S34T.0300.34	3	0,4	0,25	34T02N	△	▲
S34T.0400.32	4	0,2	0,25	34T03N	▲	▲
S34T.0500.34	5	0,4	0,25	34T04N	▲	▲
					P ● ●	
					M ● ○	
					K ● ○	
					N ○ -	
					S ● -	
					H - -	

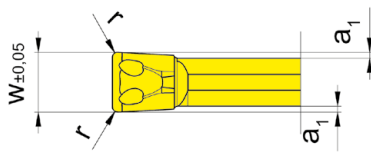
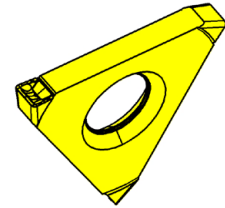
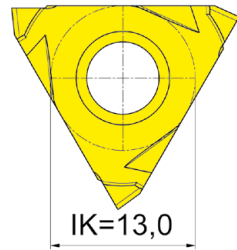
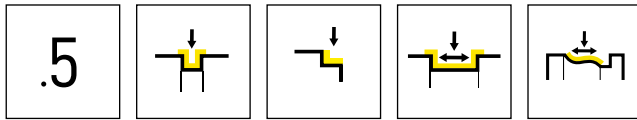

HM-Sorten
Carbide grades

▲ ab Lager
on stock

△ 4 Wochen
4 weeks

Bestellnummer Part number	w	r	a ₁	HIS	HM-Sorten	
					AS45	EG55
S34T.0250.52	2,5	0,2	0,25	34T02N	▲	
S34T.0250.54	2,5	0,4	0,25	34T02N	▲	▲
S34T.0300.52	3	0,2	0,25	34T02N	△	▲
S34T.0300.54	3	0,4	0,25	34T02N	△	▲
S34T.0400.52	4	0,2	0,25	34T03N	▲	
S34T.0400.54	4	0,4	0,25	34T03N	▲	▲
S34T.0500.54	5	0,4	0,25	34T04N		
					P	● ●
					M	● ●
					K	● ●
					N	○ -
					S	● -
					H	- -

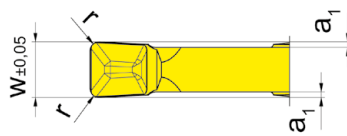
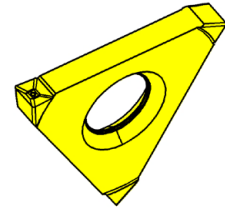
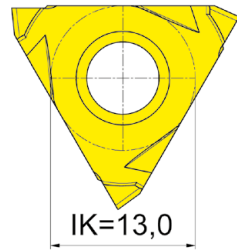
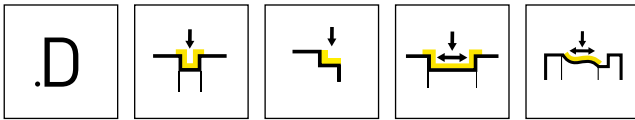

HM-Sorten
Carbide grades

▲ ab Lager
on stock

△ 4 Wochen
4 weeks

Bestellnummer Part number	w	r	a ₁	HIS	AS45	EG55
S34T.0200.D2	2	0,2	0,25	34T01N	▲	▲
S34T.0200.D4	2	0,4	0,25	34T01N	△	△
S34T.0250.D2	2,5	0,2	0,25	34T02N	△	
S34T.0250.D4	2,5	0,4	0,25	34T02N	▲	▲
S34T.0300.D2	3	0,2	0,25	34T02N	△	▲
S34T.0300.D4	3	0,4	0,25	34T02N	△	
					P ● ●	
					M ● ○	
					K ● ○	
					N ○ -	
					S ● -	
					H - -	

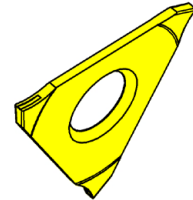
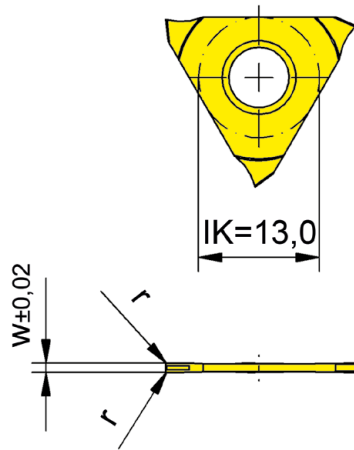
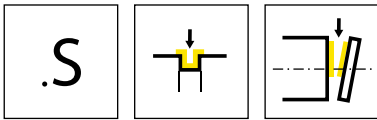

R = rechts wie gezeichnet
R = right hand version shown

L = links spiegelbildlich
L = left hand version

▲ ab Lager
on stock

HM-Sorten
Carbide grades
Δ 4 Wochen
4 weeks

Bestellnummer Part number	w	r	HIS	IG35
RS34T.0100.3S	1,03	0,15	34T00R	▲
LS34T.0100.3S	1,03	0,15	34T00L	▲
				P -
				M ●
				K -
				N -
				S ●
				H -

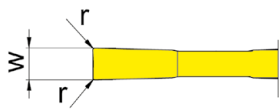
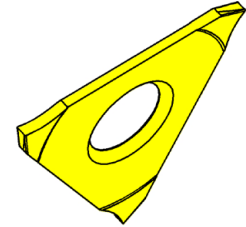
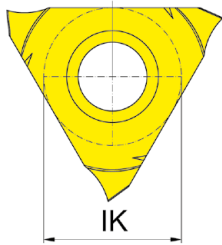
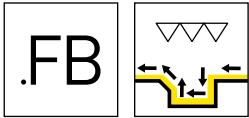

R = rechts wie gezeichnet
R = right hand version shown

L = links spiegelbildlich
L = left hand version

▲ ab Lager
on stock

HM-Sorten
Carbide grades
Δ 4 Wochen
4 weeks

Bestellnummer Part number	w	r	HIS	EG35
RS34T.FB10.01	1	0,1	34T00R	▲
RS34T.FB15.01	1,5	0,1	34T00R	▲
LS34T.FB10.01	1	0,1	34T00L	▲
LS34T.FB15.01	1,5	0,1	34T00L	▲

P	●
M	●
K	○
N	-
S	-
H	-

Berechnung der kleinstmöglichen Nutbreite w_x
Calculation of the smallest possible width of groove w_x

Beispiel RS34T.FB10.01
Example

$w_x = 2 \times \text{Schneidbreite} / \text{Width of insert } w - 2 \times \text{Eckenradius Schneidplatte} / \text{Corner radius insert } r$

$w_x = 2 \times 1 \text{ mm} - 2 \times 0,1 \text{ mm}$

$w_x = 1,8 \text{ mm}$

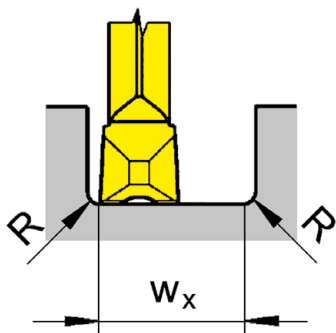

Bearbeitungsablauf
Processing flow

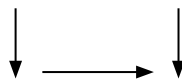



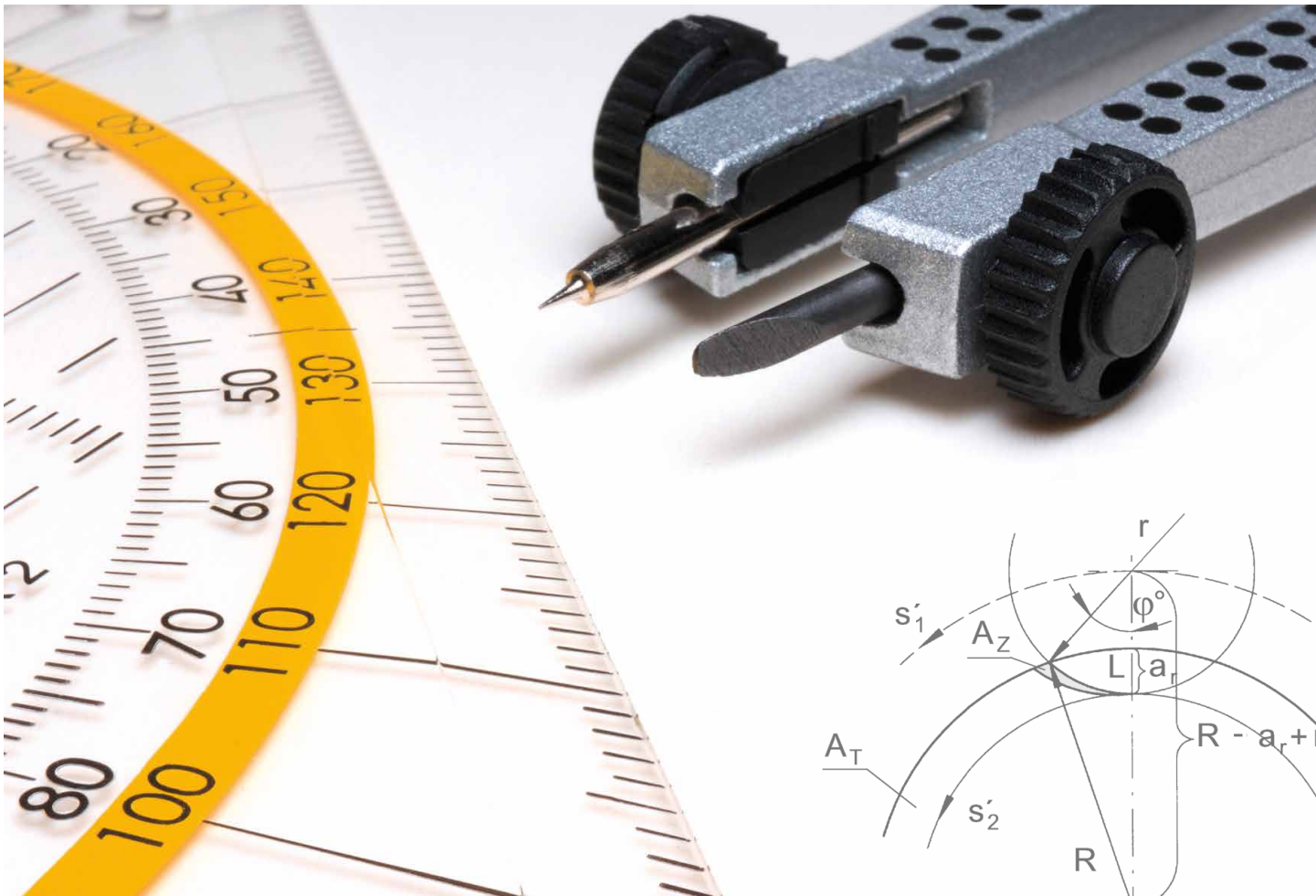

Inhalt/Summary

Seite/Page

Beschichtungsübersicht

560-561

Coating Overview

Schnittdaten

562-567

Cutting Data

Anzugsmomente

568-569

Torque of Screws

Ersatzteile Graf

570

Spare Parts Graf

Schneidstoff Material group	Schichtaufbau Coating structure	Empfehlung Recommendation						Anwendung Application
		P05	M05	K05	N05	S05	H05	
TH3_	TiAlN	P10	M10	K10	N10	S10	H10	Vor- und Fertigstechen bei mittleren Schnittgeschwindigkeiten, auch geeignet für Trockenbearbeitung Pre- and finish-grooving at medium cutting speeds, also suitable for dry machining
		P20	M20	K20	N20	S20	H20	
		P30	M30	K30	N30	S30	H30	
		P40	M40	K40	N40			
		P50	M50					
AS4_ AS6_	TiAlN	P05	M05	K05	N05	S05	H05	Ideal für das Vorstechen bei mittleren Schnittgeschwindigkeiten, auch geeignet für Trockenbearbeitung Suitable for pre-grooving at medium cutting speeds, also for dry machining
		P10	M10	K10	N10	S10	H10	
		P20	M20	K20	N20	S20	H20	
		P30	M30	K30	N30	S30	H30	
		P40	M40	K40	N40			
		P50	M50					
DD2_	TiB2	P05	M05	K05	N05	S05	H05	Vor- und Fertigstechen Pre- and finish-grooving
		P10	M10	K10	N10	S10	H10	
		P20	M20	K20	N20	S20	H20	
		P30	M30	K30	N30	S30	H30	
		P40	M40	K40	N40			
		P50	M50					
EG3_	AlTiN + TiN	P05	M05	K05	N05	S05	H05	Ideal für das Fertigstechen bei hohen Schnittgeschwindigkeiten Ideal for finish cutting at high cutting speeds
		P10	M10	K10	N10	S10	H10	
		P20	M20	K20	N20	S20	H20	
		P30	M30	K30	N30	S30	H30	
		P40	M40	K40	N40			
		P50	M50					
EG5_	AlTiN + TiN	P05	M05	K05	N05	S05	H05	Ideal für das Vorstechen bei hohen Schnittgeschwindigkeiten Ideal for pr-grooving at high cutting speeds
		P10	M10	K10	N10	S10	H10	
		P20	M20	K20	N20	S20	H20	
		P30	M30	K30	N30	S30	H30	
		P40	M40	K40	N40			
		P50	M50					
ES1_	AlTiN	P05	M05	K05	N05	S05	H05	Ideal für das Fertigstechen, Schlichten und Feinstbearbeitungen, ohne Schnittunterbrechung Ideal for finish cutting, finishing and superfinishing, without any interruption of the cut
		P10	M10	K10	N10	S10	H10	
		P20	M20	K20	N20	S20	H20	
		P30	M30	K30	N30	S30	H30	
		P40	M40	K40	N40			
		P50	M50					

Beschichtungsübersicht

Coating Overview



Schneidstoff Material group	Schichtaufbau Coating structure	Empfehlung Recommendation						Anwendung Application
		P05	M05	K05	N05	S05	H05	
IG3_	TiAlSiN	P05	M05	K05	N05	S05	H05	Ideal für Fertigstecken bei hohen Schnittgeschwindigkeiten, auch geeignet für Trockenbearbeitung
		P10	M10	K10	N10	S10	H10	
		P20	M20	K20	N20	S20	H20	
		P30	M30	K30	N30	S30	H30	Ideal for finish-grooving at high cutting speeds, also suitable for dry machining
		P40	M40	K40	N40			
		P50	M50					
IG6_	TiAlSiN	P05	M05	K05	N05	S05	H05	Ideal für das Vorstecken bei hohen Schnittgeschwindigkeiten, auch geeignet für Trockenbearbeitung
		P10	M10	K10	N10	S10	H10	
		P20	M20	K20	N20	S20	H20	
		P30	M30	K30	N30	S30	H30	Pre- and finish-grooving at high cutting speeds, also suitable for dry machining
		P40	M40	K40	N40			
		P50	M50					
NE2_	ta-C	P05	M05	K05	N05	S05	H05	Vor- und Fertigstecken ohne Schnittunterbrechung
		P10	M10	K10	N10	S10	H10	
		P20	M20	K20	N20	S20	H20	
		P30	M30	K30	N30	S30	H30	Pre- and finish-grooving, without any interruption of the cut
		P40	M40	K40	N40			
		P50	M50					
SG3_	TiAlCrSiN	P05	M05	K05	N05	S05	H05	Vor- und Fertigstecken
		P10	M10	K10	N10	S10	H10	
		P20	M20	K20	N20	S20	H20	
		P30	M30	K30	N30	S30	H30	Pre- and finish-grooving
		P40	M40	K40	N40			
		P50	M50					
TI2_	TiCn	P05	M05	K05	N05	S05	H05	Vor- und Fertigstecken bei moderaten Schnittgeschwindigkeiten, Reduzierung von Aufbauschneiden
		P10	M10	K10	N10	S10	H10	
		P20	M20	K20	N20	S20	H20	
		P30	M30	K30	N30	S30	H30	Pre- and finish-grooving at moderate cutting speeds, reduction of built-up edges
		P40	M40	K40	N40			
		P50	M50					
TN3_	TiN	P05	M05	K05	N05	S05	H05	Vor- und Fertigstecken bei moderaten Schnittgeschwindigkeiten
		P10	M10	K10	N10	S10	H10	
		P20	M20	K20	N20	S20	H20	
		P30	M30	K30	N30	S30	H30	Pre- and finish-grooving at moderate cutting speeds
		P40	M40	K40	N40			
		P50	M50					

ISO 513		P	M	K	N	S	H
+ Zähigkeit / Tenacity	- Verschleißfestigkeit / Wear resistance	05	05	05	05	05	05
		10	10	10	10	10	10
		20	20	20	20	20	20
		30	30	30	30	30	30
		40	40	40	40		
		50	50				

Werkstoff Material		Materialgruppe Material group	Härte (HB) Hardness Brinell	Zugfestigkeit R_m [N/mm ²] Tensile Strength	Beispiel Werkstoff Example Material	
P	unlegierter Stahl Carbon steel	~ 0,2 % C	P1.1	125	430	CK15
		~ 0,4% C geglüht annealed	P1.2	190	610	19Mn6
		~ 0,4% C vergütet quenched	P1.3	210	640	36Mn5
		~ 0,6% C geglüht annealed	P1.4	190	610	C55
		~ 0,6% C vergütet quenched	P1.5	300	1000	CK60
		Automatenstahl Free cutting steel	P1.6	220	750	9SMn28
	niedrig legierter Stahl (<5%) Alloyed steel	geglüht annealed	P2.1	180	590	100Cr6
		vergütet quenched	P2.2	280	960	14NiCr10
		vergütet quenched	P2.3	350	1250	34CrMo4
		vergütet quenched	P2.4	430	1450	55Cr3
	hochlegierter Stahl (>5%) high alloyed steel	geglüht annealed	P3.1	200	680	X10CrAl18
		gehärtet hardened	P3.2	350	1200	X210Cr2
	Stahlguss Cast steel	unlegiert unalloyed	P4.1	180	590	GE200
		legiert alloyed	P4.2	220	750	GX40CrSi28
	Sinterstahl Sintered steel	weich soft	P5.1	220	570	Sint-D39
M	Rostfreier Stahl Stainless steel	martensitisch ferritisch martensitic ferritic	M1.1	200	680	X16Cr13
		austenitisch austenitic	M1.2	300	1000	X6CrNiMo- Ti17-12-2
		austenitisch ferritisch austenitic ferritic	M1.3	230	780	X2CrNi- Mo-N17-13-3
H	Gehärtete Stähle Hardened steels	50-55 HRC	H1.1	-	-	
		55-60 HRC	H1.2	-	-	
		60-63 HRC	H1.3	-	-	
		> 63HRC	H1.4	-	-	

Werkstoff Material		Materialgruppe Material group	Härte (HB) Hardness Brinell	Zugfestigkeit R_m [N/mm ²] Tensile Strength	Beispiel Werkstoff Example Material	
K	Grauguss Grey cast iron	niedrige Festigkeit low tensile strength	K1.1	180	250	GG-25
		hohe Festigkeit high tensile strength	K1.2	250	350	GG-40
	Kugelgraphitguss Spheroidal graphite cast iron	ferritisch ferritic	K2.1	160	400	GGG-40
		perlitisches perlitic	K2.1	260	700	GGG-60
	Temperguss Malleable cast iron	ferritisch ferritic	K3.1	200	400	GTW-45
		perlitisches perlitic	K3.2	260	700	GTS-55-04
	Ausferritisches Gusseisen / ADI Ausferritic spheroidal cast iron / ADI	vergütet quenched	K4.1	260	800	
		vergütet quenched	K4.2	350	1050	
		vergütet quenched	K4.3	450	1400	
N	Al-Legierungen Al-alloys	nicht vergütbar not heat treatable	N1.1	30		AlMg1
		vergütbar heat treatable	N1.2	100	340	AlMgSi1
	Al-Guss- Legierung Al-cast-alloy	< 6% Si	N2.1	80	300	AlMgSi6
		6-10% Si	N2.2	100	320	AlSi7Mg
		10-15 % Si	N2.3	130	450	AlSi12
	Kupfer- Legierungen Copper-alloys	Reinkupfer Pure copper	N3.1	100	340	Cu
		Messing, Bronze Brass	N3.2	90	310	CuZn40Pb
		Messing bleifrei Lead-free brass	N3.3	110	430	CuZn40
		hochfest high strength	N3.4	300	1000	CuZ- n25Al5-Mn4Fe3
	Graphit Graphite		N4.1			
S	Warmfeste Legierung (Fe) Heat resistant alloy	geglüht annealed	S1.1	200	670	
		gehärtet hardened	S1.2	275	930	
	Warmfeste Legierung (Ni, Co) Heat resistant alloy	geglüht annealed	S2.1	250	840	Inconel 600
		gehärtet hardened	S2.2	350	1200	Inconel 713

Schnittdaten

Cutting Data



N

Schnittgeschwindigkeit vc (m/min) / Startwerte Cutting speed vc (m/min) / Start values										
	K10 MG12	TN3_	TI2_	TH3_ TF4_ AS4_ AS6_	ES1_	EG3_ EG5_ HP6_	IG3_ IG6_	DD2_	SG3_	H20 H54 IG6T
	90- 60	140-90		200 - 120	200 - 120	200 - 120	250 -140		250 -140	
	90 -60	110-90		160 - 120	160 - 120	160 - 120	220 - 150		220 - 150	
		110-80		180 - 130	180 - 130	180 - 130	240 - 160		240 - 160	
		110-80		160 - 120	160 - 120	160 - 120	200 - 160		200 - 160	
		150-90		220 - 120	220 - 120	220 - 120	280 - 180		280 - 180	
		130-60		190 - 100	190 - 100	190 - 100	250 - 160		250 - 160	
		110-60		180 - 90	180 - 90	180 - 90				
		110-60		160 - 80	160 - 80	160 - 80				
		80-50		120 - 60	120 - 60	120 - 60				
	600-400							1000 - 600		500 - 350
	400-200							600-300		350 - 300
	600 - 300							1000 -600		500 - 350
								400 - 220		350 - 300
	200 - 120							400 - 220		
	200 - 120							300 - 180		
	150 - 90							250 - 120		
	150 -90							200 - 80		
	50-30						80 - 60		90-70	
	50-30						50 - 30		60-40	
	50-30						70 - 50		80-60	
	50-30						60 - 40		70-50	

Werkstoff Material		Materialgruppe Material group	Härte (HB) Hardness Brinell	Zugfestigkeit R_m [N/mm ²] Tensile Strength	Beispiel Werkstoff Example Material
S	Titan	Titanlegierung α Titanium alloy α	S3.1	120	240
		Titanlegierung α - β Titanium alloy α - β	S3.2	360	1200
		Titanlegierung β Titanium alloy β	S3.3	410	1400
O	Thermoplaste Thermoplastics		01.1		
	Duroplaste Duro plaste		01.2		
	Kunststoffe glas- faserverstärkt Plastics glass fibre reinforced	GFK	01.3		
	Kunststoffe kohle- faserverstärkt Plastics carbon fibre reinforced	CKF	01.4		

Schnittdaten

Cutting Data



N

	Schnittgeschwindigkeit vc (m/min) / Startwerte Cutting speed vc (m/min) / Start values									
	K10 MG12	TN3_	TI2_	TH3_ TF4_ AS4_ AS6_	ES1_	EG3_ EG5_ HP6_	IG3_ IG6_	DD2_	SG3_	H20 H54 IG6T
	50-30						150 - 110		160-120	
	50-30						80 - 60		90-70	
	50-30						50 - 45		60-50	
	150 - 50									
	150 - 100									
	150 - 100									
	300 - 150									

Nachstehende Drehmomente sind für die Spannschrauben zulässig. Wir empfehlen keine zusätzlichen Gleitmittel wie Kupferpaste oder ähnliches für die Schrauben zu verwenden. Die passenden Drehmomentschlüssel finden Sie im Kapitel Zubehör.

Following torques are allowed for screws of inserts. We recommend to use no additional gliding means (such as copper paste) for screws. For torque screw drivers please see chapter additional equipment.

Typ Type	Schraube Screw	M_d Nm	Schlüssel Clamping wrench	Klinge Blade
76	030.3509.T15P	5,0	T15PQ	DT15PK
360	6.25	4,5	SW3DIN911	DSW30K
361	030.0422.T10P	3,0	T10PL	DT10PK
368	4.15T15P	4,0	T15PQ	DT15PK
368...10.01	030.0422.T10	4,0	T10PL	DT10PK
369	6.25	4,5	SW3DIN911	DSW30K
390	6.25	4,5	SW3DIN911	DSW30K
391.1212...	030.0422.T10P	3,0	T10PL	DT10PK
391.1616...	5.32.3T15P	5,0	T15PQ	DT15PK
391.2...	6.25	4,5	SW3DIN911	DSW30K
H32T...IK	030.2507.T7P	1,5	T7PL	DT7PK
H34T...00.IK H34T...10.IK	030.4093.T15P	3,0	T15PQ	DT15PK
H34T...20.IK	030.4010.T15P	5,0	T15PQ	DT15PK
H34T...30.IK	030.5012.T15P	6,0	T15PQ	DT15PK
H34T...40.IK	030.5012.T20P	6,0	T20PQ	DT20PK/DT20PQ
H100...01/...11/...21 + IK H100...02/...12/...22 + IK H100...5.23.IK H100...71/...72 H100...71R/L/...72R/L	4.15T15P	5,0	T15PQ	DT15PK
H100...03/...13/...23 H100...61/...63	3.5.12T10EP	3,5	T15PQ	DT15PK
H100...03/...13/...23 H100...04/...14/...24 H100...15 H100...3.22.IK	5.17T20P	6,5	T20PQ	DT20PK/DT20PQ
H100...23.IK/...24.IK H100...73/...74 + IK	6.23T25P	7,0	T25PQ	DT25PK/DT25PQ
H100...83/...84 + R/L/N	030.505P.0718	5,0	T15PQ	DT15PK
H100...93/...93R/L	030.0413.T15P	3,0	T15PQ	DT15PK
H100.52... H100...4.72...IK/...4.73...IK	5.13T20P	5,0	T20PQ	DT20PK/DT20PQ
H224	6.23T25P	6,0	T25PQ	DT25PK/DT25PQ
H224.1212.81	6.17T25P	5,0	T25PQ	DT15PK
H224.1608.02/.23/.24	4.15T15P	5,0	T15PQ	DT15PK
H224...61/..62/..63/..64+IK	4.12.T15EP	5,0	T15PL	DT15PK
H224...65/...66/...83R	5.13.T20EP	6,5	T20PQ	DT20PK/DT20PQ

Anzugsmomente

Torque of Screws



Typ Type	Schraube Screw	M_d Nm	Schlüssel Clamping wrench	Klinge Blade
H262	030.2557.T8P	1,0	T8PL	DT8PK
H264	3.5.12T10EP	3,0	T10PL	DT10PK
H274.0808.04	030.350R.0744	3,0	T15PQ	DT15PK
H274...04/...04.E H274...24.IK	030.3509.T15P	3,0	T15PQ	DT15PK
H274...6.04/...6.04.M	030.350P.0981	3,0	T15PQ	DT15PK
H274...07 H274.A...	030.3513.T15P	3,0	T15PQ	DT15PK
KT274 KTC274	030.3509.T15P	3,0	T15PQ	DT15PK
L368	4.18T15EP	4,0	T15PQ	DT15PK
LNK368	5.10T20P	6,0	T20PQ	DT20PK/DT20PQ
LNK760	5.13T20EP	6,0	T20PQ	DT20PK/DT20PQ



Kühlmittelanschluss Standard für Rohr Ø 6 mm

Standard connection for coolant supply for pipe Ø 6 mm



Kühlmittelanschluss,
gerade
Connection for coolant
supply, straight screwed

A	B	Bestellnummer Part number
M8 x 1	Ø 6 mm	004.00.19
G1/8"	Ø 6 mm	004.00.14

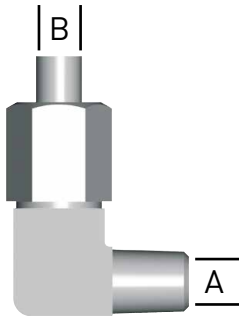

Kühlmittelanschluss,
winkelig fest
Connection for coolant
supply, angled and fix

A	B	Bestellnummer Part number
M8 x 1	Ø 6 mm	004.00.22
G1/8"	Ø 6 mm	004.00.33

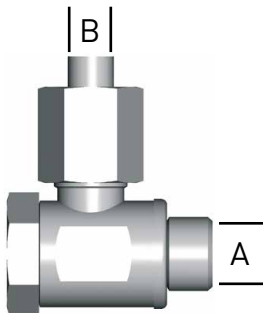

Schwenkverschraubung
Swivelling screw-fitting

A	B	Bestellnummer Part number
M8 x 1	Ø 6 mm	004.00.61
G1/8"	Ø 6 mm	004.00.16

Kühlmittelanschluss Schnellkupplung

Clip connection for coolant supply

Schnellkupplung
Quick connector

M10 x 1 - 004.00.49



Stecker
Plug

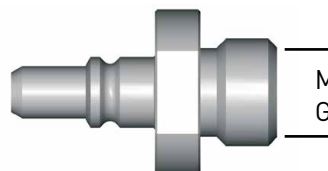

M8 x 1 - 004.00.56
G1/8" - 004.00.57

Stecker
Plug

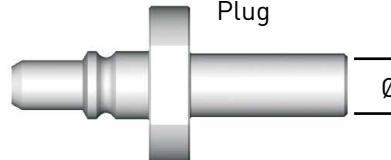

Ø 6 mm - 004.00.59



**Gewindedrehen
(außen und innen)**

**Threading
(external and internal)**

Wendeschnidplatte
Indexable insert
S224/NS224/264/S274
S274...E/S32T

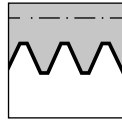

Seite/Page
573-582

Technische Hinweise
Technical Instructions

Seite/Page
583-584

Die passenden Klemmhalter finden Sie in den entsprechenden System-Kapiteln
For toolholder please see corresponding system chapters

Anwendungen

Application



Gewinde Teilprofil
Partial profile thread



Gewinde Vollprofil
Full profile thread

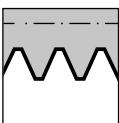

Gewinde außen
External thread



Metrisches ISO-Gewinde
Metric ISO thread

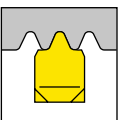

Whitworth-Rohrgewinde
Whitworth pipe thread

Keine Unterlegplatte erforderlich. Sämtliche HORN-Gewindeprofile sind mit einem **KEGELMANTEL-FREISCHLIFF** versehen.

No shims necessary. All HORN thread profiles are manufactured with full ground radial clearance.

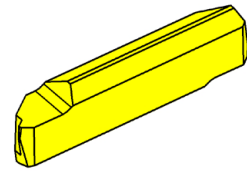
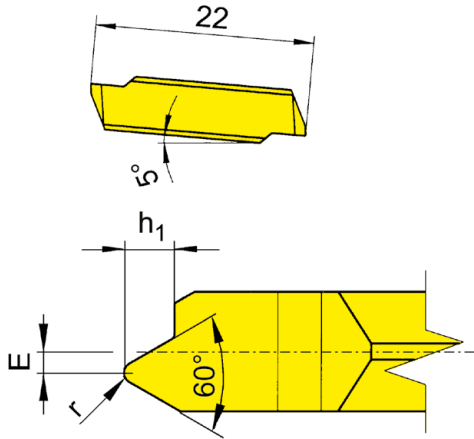

R = rechts wie gezeichnet
R = right hand version shown

L = links spiegelbildlich
L = left hand version

▲ ab Lager
on stock

HM-Sorten
Carbide grades
Δ 4 Wochen
4 weeks

Bestellnummer Part number	P	E	r	h ₁	HIS	EG55	TF45
RS224.0305.02	0,5	1	0,07	0,31	224038	▲	▲
RS224.0407.02	0,75	0,9	0,11	0,46	224038	▲	▲
RS224.0610.02	1	0,8	0,14	0,61	224038	▲	▲
RS224.0712.02	1,25	0,7	0,15	0,77	224038	▲	▲
RS224.0915.02	1,5	0,5	0,2	0,92	224038	▲	▲
RS224.1017.02	1,75	0,4	0,25	1,07	224038	▲	▲
RS224.1220.02	2	0,3	0,25	1,23	224038	▲	▲
LS224.0305.02	0,5	1	0,07	0,31	224038	Δ	▲
LS224.0407.02	0,75	0,9	0,11	0,46	224038	▲	▲
LS224.0610.02	1	0,8	0,14	0,61	224038	▲	▲
LS224.0712.02	1,25	0,7	0,15	0,77	224038	▲	▲
LS224.0915.02	1,5	0,5	0,2	0,92	224038	▲	▲
LS224.1017.02	1,75	0,4	0,25	1,07	224038	Δ	Δ
LS224.1220.02	2	0,3	0,25	1,23	224038	Δ	▲

Besonders geeignet für die hinter Bund Bearbeitung
Particularly suitable for threading behind a shoulder

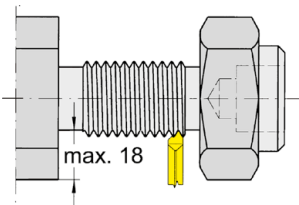

P	●	●
M	○	●
K	○	●
N	-	●
S	-	●
H	-	-

Wendeschneidplatte

Indexable insert

NS224



0

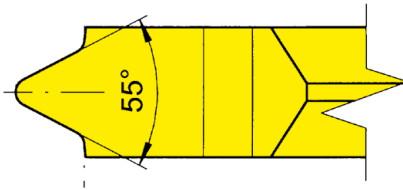
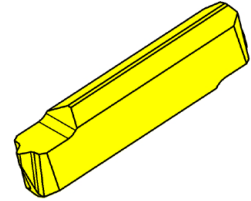
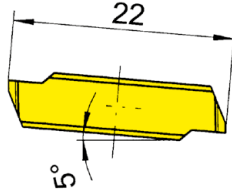

HM-Sorten
Carbide grades

▲ ab Lager
on stock

△ 4 Wochen
4 weeks

Bestellnummer Part number	TPI	HIS	HM-Sorten Carbide grades	
			EG55	TA45
NS224.5511.02	11	224038	▲	▲
NS224.5514.02	14	224038	▲	▲
NS224.5519.02	19	224038	▲	▲
NS224.5528.02	28	224038	▲	▲
			P	●
			M	○
			K	○
			N	-
			S	-
			H	-

Besonders geeignet für die hinter Bund Bearbeitung
Particularly suitable for threading behind a shoulder

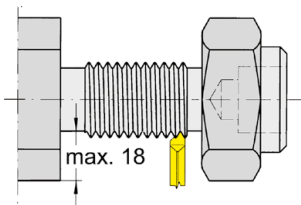

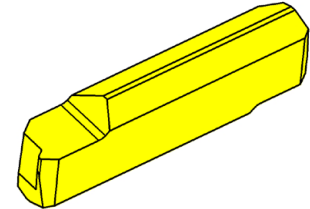
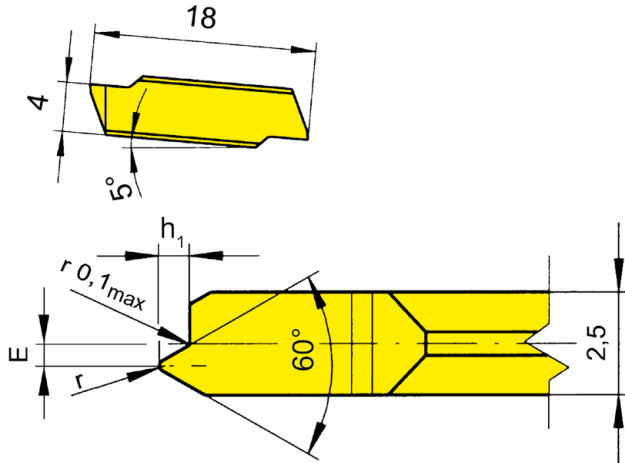

R = rechts wie gezeichnet
R = right hand version shown

L = links spiegelbildlich
L = left hand version

▲ ab Lager
on stock

HM-Sorten
Carbide grades
Δ 4 Wochen
4 weeks

Bestellnummer Part number	P	E	r	h ₁	HIS	TF45
R264.0305.02	0,5	0,9	0,07	0,31	26403	▲
R264.0306.02	0,6	0,9	0,09	0,37	26403	Δ
R264.0307.02	0,7	0,8	0,1	0,43	26403	▲
R264.0407.02	0,75	0,75	0,11	0,46	26403	▲
R264.0408.02	0,8	0,7	0,12	0,49	26403	▲
R264.0610.02	1	0,6	0,12	0,61	26403	▲
R264.0712.02	1,25	0,5	0,15	0,77	26403	▲
R264.0915.02	1,5	0,4	0,2	0,92	26403	▲
L264.0305.02	0,5	0,9	0,07	0,31	26403	Δ
L264.0306.02	0,6	0,9	0,09	0,37	26403	Δ
L264.0307.02	0,7	0,8	0,1	0,43	26403	Δ
L264.0407.02	0,75	0,75	0,11	0,46	26403	Δ
L264.0408.02	0,8	0,7	0,12	0,49	26403	▲
L264.0610.02	1	0,6	0,12	0,61	26403	▲
L264.0712.02	1,25	0,5	0,15	0,77	26403	Δ
L264.0915.02	1,5	0,4	0,2	0,92	26403	Δ

P	●
M	●
K	●
N	●
S	●
H	-

0

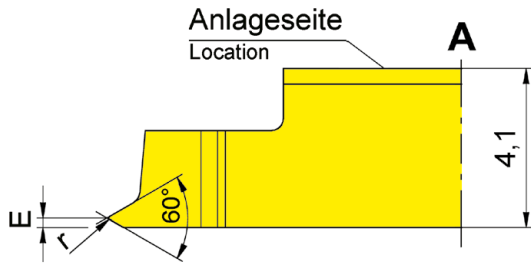
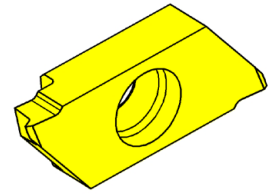
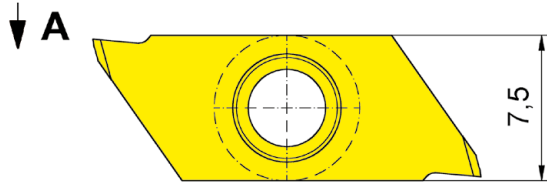

R = rechts wie gezeichnet
R = right hand version shown

▲ ab Lager
on stock

HM-Sorten
Carbide grades
Δ 4 Wochen
4 weeks

Bestellnummer Part number	P	E	r	HIS	IG35	TH35
RS274.0102.01	0,25	0,2	0,04	274040R	▲	▲
RS274.0203.01	0,35	0,25	0,05	274040R	▲	▲
RS274.0204.01	0,4	0,3	0,06	274040R	▲	▲
	P	-	●			
	M	●	●			
	K	-	●			
	N	-	●			
	S	●	●			
	H	-	-			

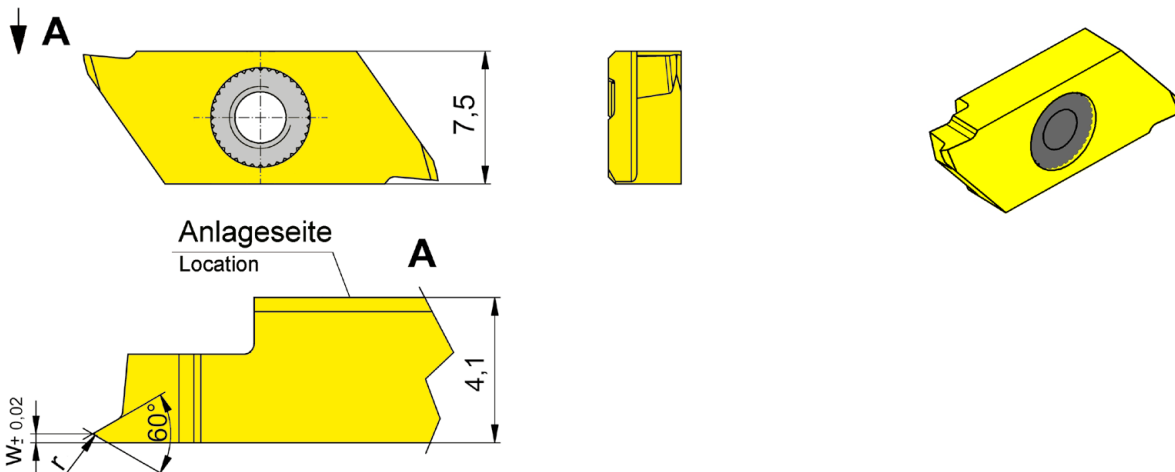

R = rechts wie gezeichnet
R = right hand version shown

▲ ab Lager
on stock

HM-Sorten
Carbide grades
Δ 4 Wochen
4 weeks

Bestellnummer Part number	P	E	r	HIS	HM-Sorten Carbide grades	
					IG35	TH35
RS274.0102.01.E	0,25	0,2	0,04	274140R	Δ	Δ
RS274.0203.01.E	0,35	0,25	0,05	274140R	Δ	Δ
RS274.0204.01.E	0,4	0,3	0,06	274140R	Δ	Δ
	P	-	●			
	M	●	●			
	K	-	●			
	N	-	●			
	S	●	●			
	H	-	-			

0

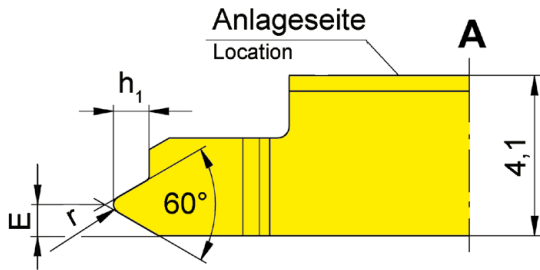
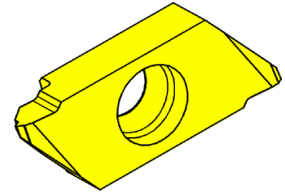
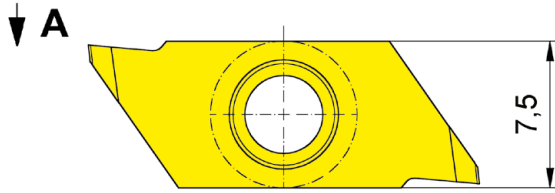

R = rechts wie gezeichnet
R = right hand version shown

L = links spiegelbildlich
L = left hand version

▲ ab Lager
on stock

HM-Sorten
Carbide grades
Δ 4 Wochen
4 weeks

Bestellnummer Part number	P	E	r	h ₁	HIS	IG35	TH35
RS274.0305.02	0,5	0,4	0,07	0,31	274040R	▲	▲
RS274.0306.02	0,6	0,45	0,09	0,37	274040R	Δ	▲
RS274.0307.02	0,7	0,5	0,1	0,43	274040R	▲	▲
RS274.0407.02	0,75	0,5	0,11	0,46	274040R	▲	▲
RS274.0408.02	0,8	0,55	0,12	0,49	274040R	▲	▲
RS274.0610.02	1	0,6	0,14	0,61	274040R	▲	▲
RS274.0712.02	1,25	0,7	0,15	0,77	274040R	▲	▲
RS274.0915.02	1,5	0,8	0,2	0,92	274040R	▲	▲
LS274.0305.02	0,5	0,4	0,07	0,31	274040L	Δ	▲
LS274.0306.02	0,6	0,45	0,09	0,37	274040L	Δ	Δ
LS274.0307.02	0,7	0,5	0,1	0,43	274040L	Δ	Δ
LS274.0407.02	0,75	0,5	0,11	0,46	274040L	Δ	Δ
LS274.0408.02	0,8	0,55	0,12	0,49	274040L	Δ	Δ
LS274.0610.02	1	0,6	0,14	0,61	274040L	Δ	▲
LS274.0712.02	1,25	0,7	0,15	0,77	274040L	▲	▲
LS274.0915.02	1,5	0,8	0,2	0,92	274040L	Δ	Δ
						P	- ●
						M	● ●
						K	- ●
						N	- ●
						S	● ●
						H	- -

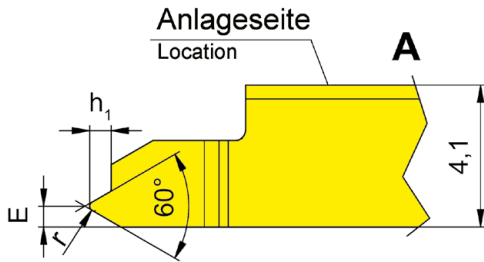
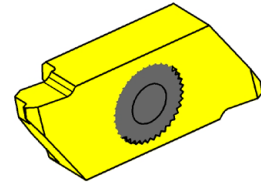
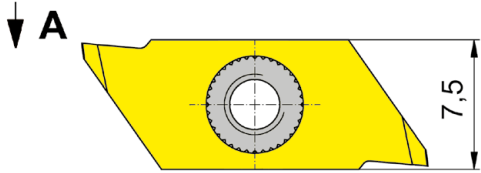

R = rechts wie gezeichnet
R = right hand version shown

L = links spiegelbildlich
L = left hand version

▲ ab Lager
on stock

HM-Sorten
Carbide grades
▲ 4 Wochen
4 weeks

Bestellnummer Part number	P	E	r	h ₁	HIS	IG35	TH35
RS274.0305.02.E	0,5	0,4	0,07	0,31	274140R	Δ	Δ
RS274.0306.02.E	0,6	0,45	0,09	0,37	274140R	Δ	Δ
RS274.0307.02.E	0,7	0,5	0,1	0,43	274140R	Δ	Δ
RS274.0407.02.E	0,75	0,5	0,11	0,46	274140R	Δ	Δ
RS274.0408.02.E	0,8	0,55	0,12	0,49	274140R	Δ	Δ
RS274.0610.02.E	1	0,6	0,14	0,61	274140R	Δ	Δ
RS274.0712.02.E	1,25	0,7	0,15	0,77	274140R	Δ	Δ
RS274.0915.02.E	1,5	0,8	0,2	0,92	274140R	Δ	Δ
LS274.0305.02.E	0,5	0,4	0,07	0,31	274140L	Δ	Δ
LS274.0306.02.E	0,6	0,45	0,09	0,37	274140L	Δ	Δ
LS274.0307.02.E	0,7	0,5	0,1	0,43	274140L	Δ	Δ
LS274.0407.02.E	0,75	0,5	0,11	0,46	274140L	Δ	Δ
LS274.0408.02.E	0,8	0,55	0,12	0,49	274140L	Δ	Δ
LS274.0610.02.E	1	0,6	0,14	0,61	274140L	Δ	Δ
LS274.0712.02.E	1,25	0,7	0,15	0,77	274140L	Δ	Δ
LS274.0915.02.E	1,5	0,8	0,2	0,92	274140L	Δ	Δ
P	-	●					
M	●	●					
K	-	●					
N	-	●					
S	●	●					
H	-	-					

0

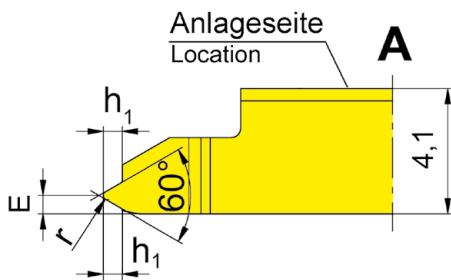
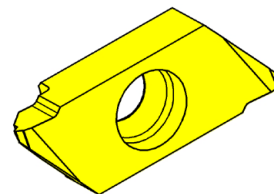
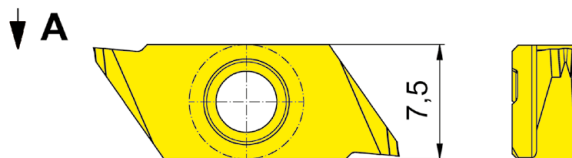

R = rechts wie gezeichnet
R = right hand version shown

L = links spiegelbildlich
L = left hand version

▲ ab Lager
on stock

HM-Sorten
Carbide grades
Δ 4 Wochen
4 weeks

Bestellnummer Part number	P	E	r	h ₁	HIS	IG35	TH35
RS274.0305.03	0,5	0,4	0,07	0,31	274040R	Δ	▲
RS274.0306.03	0,6	0,45	0,09	0,37	274040R	Δ	Δ
RS274.0307.03	0,7	0,5	0,1	0,43	274040R	Δ	▲
RS274.0407.03	0,75	0,5	0,11	0,46	274040R	Δ	Δ
RS274.0408.03	0,8	0,55	0,12	0,49	274040R	Δ	Δ
RS274.0610.03	1	0,6	0,14	0,61	274040R	▲	▲
RS274.0712.03	1,25	0,7	0,15	0,77	274040R	Δ	Δ
RS274.0915.03	1,5	0,8	0,2	0,92	274040R	Δ	▲
LS274.0305.03	0,5	0,4	0,07	0,31	274040L	Δ	▲
LS274.0306.03	0,6	0,45	0,09	0,37	274040L	Δ	
LS274.0307.03	0,7	0,5	0,1	0,43	274040L	Δ	Δ
LS274.0407.03	0,75	0,5	0,11	0,46	274040L	Δ	Δ
LS274.0408.03	0,8	0,55	0,12	0,49	274040L	Δ	Δ
LS274.0610.03	1	0,6	0,14	0,61	274040L	Δ	Δ
LS274.0712.03	1,25	0,7	0,15	0,77	274040L	Δ	Δ
LS274.0915.03	1,5	0,8	0,2	0,92	274040L	Δ	Δ

Bearbeitung beider Flanken
Machining of both flanks

P	-	●
M	●	●
K	-	●
N	-	●
S	●	●
H	-	-

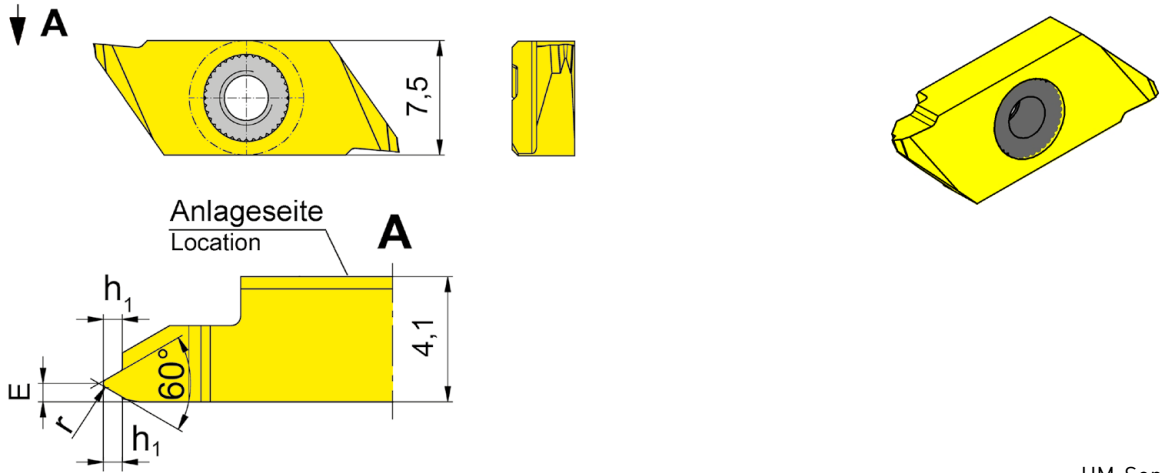

R = rechts wie gezeichnet
R = right hand version shown

L = links spiegelbildlich
L = left hand version

▲ ab Lager
on stock

HM-Sorten
Carbide grades
Δ 4 Wochen
4 weeks

Bestellnummer Part number	P	E	r	h ₁	HIS	IG35	TH35
RS274.0305.03.E	0,5	0,4	0,07	0,31	274140R	Δ	Δ
RS274.0306.03.E	0,6	0,45	0,09	0,37	274140R	Δ	Δ
RS274.0307.03.E	0,7	0,5	0,1	0,43	274140R	Δ	Δ
RS274.0407.03.E	0,75	0,5	0,11	0,46	274140R	Δ	Δ
RS274.0408.03.E	0,8	0,55	0,12	0,49	274140R	Δ	Δ
RS274.0610.03.E	1	0,6	0,14	0,61	274140R	Δ	Δ
RS274.0712.03.E	1,25	0,7	0,15	0,77	274140R	Δ	Δ
RS274.0915.03.E	1,5	0,8	0,2	0,92	274140R	Δ	Δ
LS274.0305.03.E	0,5	0,4	0,07	0,31	274140L	Δ	Δ
LS274.0306.03.E	0,6	0,45	0,09	0,37	274140L	Δ	Δ
LS274.0307.03.E	0,7	0,5	0,1	0,43	274140L	Δ	Δ
LS274.0407.03.E	0,75	0,5	0,11	0,46	274140L	Δ	Δ
LS274.0408.03.E	0,8	0,55	0,12	0,49	274140L	Δ	Δ
LS274.0610.03.E	1	0,6	0,14	0,61	274140L	Δ	Δ
LS274.0712.03.E	1,25	0,7	0,15	0,77	274140L	Δ	Δ
LS274.0915.03.E	1,5	0,8	0,2	0,92	274140L	Δ	Δ

Bearbeitung beider Flanken
Machining of both flanks

P	-	●
M	●	●
K	-	●
N	-	●
S	●	●
H	-	-

0

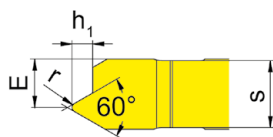
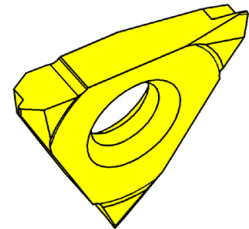
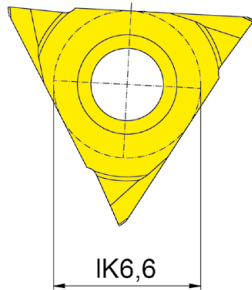

R = rechts wie gezeichnet
R = right hand version shown

L = links spiegelbildlich
L = left hand version

▲ ab Lager
on stock

HM-Sorten
Carbide grades
Δ 4 Wochen
4 weeks

Bestellnummer Part number	P	E	r	h ₁	s	HIS	EG55
RS32T.0305.02	0,5	1,6	0,07	0,32	2	32T02R	▲
RS32T.0306.02	0,6	1,5	0,09	0,38	2	32T02R	▲
RS32T.0307.02	0,7	1,5	0,1	0,44	2	32T02R	▲
RS32T.0407.02	0,75	1,5	0,11	0,47	2	32T02R	▲
RS32T.0408.02	0,8	1,4	0,12	0,5	2	32T02R	▲
RS32T.0610.02	1	1,4	0,14	0,62	2	32T02R	▲
RS32T.0712.02	1,25	1,4	0,18	0,78	2	32T02R	▲
RS32T.0915.02	1,5	1,3	0,22	0,93	2	32T02R	▲
LS32T.0305.02	0,5	1,6	0,07	0,32	2	32T02L	▲
LS32T.0306.02	0,6	1,5	0,09	0,38	2	32T02L	▲
LS32T.0307.02	0,7	1,5	0,1	0,44	2	32T02L	▲
LS32T.0407.02	0,75	1,5	0,11	0,47	2	32T02L	▲
LS32T.0408.02	0,8	1,4	0,12	0,5	2	32T02L	▲
LS32T.0610.02	1	1,4	0,14	0,62	2	32T02L	▲
LS32T.0712.02	1,25	1,4	0,18	0,78	2	32T02L	▲
LS32T.0915.02	1,5	1,3	0,22	0,93	2	32T02L	▲
	P	●					
	M	o					
	K	o					
	N	-					
	S	-					
	H	-					

Empfohlene Anzahl der Schnitte

Recommended number of passes

V _{max} m/min	Stahl (Nmm ² Festigkeit) Steel (N/mm ² Tensile strength)					rostfr. Stahl Stainless steel	Grauguss Grey cast iron	Al
	400-500	500-700	700-850	850-1150	> 1150			
	160	140	120	90	70	90	100	300

Steigung Pitch		Anzahl der Schnitte Number of passes							
mm	Gg/'' tpi	Stahl (Nmm ² Festigkeit) Steel (N/mm ² Tensile strength)					rostfr. Stahl Stainless steel	Grauguss Grey cast iron	Al
		400-500	500-700	700-850	850-1150	> 1150			
0,8	32	8	8	9	9	10	10	9	8
1,0	24	10	10	12	12	12	12	12	10
1,25	20-19	12	12	14	14	15	15	14	12
1,5	16	15	15	17	17	18	18	17	15
1,75	14	17	17	19	19	21	21	18	17
2,0	12-11	19	20	22	22	25	25	20	18
2,5	10	22	24	26	26	31	31	22	20
3,0-3,5	8	28	30	32	32	38	38	24	22

Die Anzahl der Durchgänge für das Gewindedrehen in o.g. Tabelle sind nur Richtwerte.

Folgendes ist zu beachten:

- Beim 1. Durchgang darf die Zustellung nicht zu groß sein, um Ausbrüche an der Schneide zu vermeiden.
- Leerschnitte (ohne Zustellung) sind in der Tabelle nicht berücksichtigt.

The recommended number of passes in the above table are approxiamte figures.

Please note:

- to avoid breakages at the cutting edge, the depth of cut at the first pass should not be to deep
- finishing passes (with zero depth of cut) are not considered in the table

Vorschubsrichtung Innengewindedrehen

Feed direction internal threading

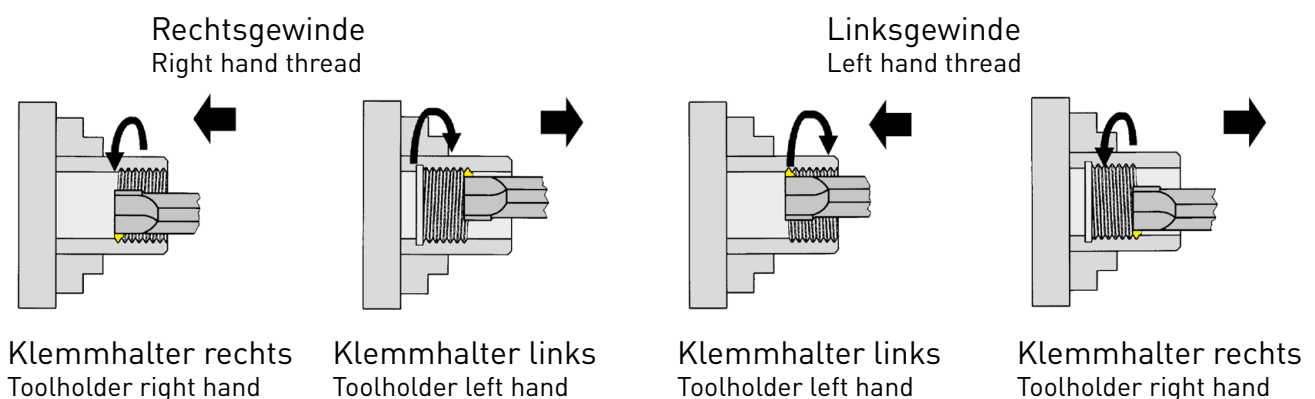

Zustellung

In-Feed

Radiale Zustellung

Die gebräuchlichste Methode Gewinde herzustellen. Beide Schneiden sind gleich-zeitig im Eingriff.

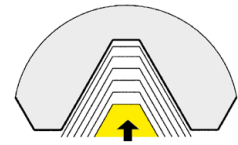

Radial In-Feed

Metal removed on both sides of the insert simultaneously. The most commonly used method for thread production.

Modifizierte Flankenzustellung

Weniger Verschleiß der Schlepplachse und eine bessere Oberflächen-güte der entsprechenden Gewindeflanke.



Modified flank in-feed

Less wear of the trailing edge and better surface finish on corresponding flank.

Wechselnde Flankenzustellung

Beide Schneidflanken werden gleichmäßig benutzt, ergibt höhere Standzeiten.



Alternating flank in-feed

Both edges are being fully utilised which means longer insert life.

Einseitige Flankenzustellung

Geringerer Schnittdruck und bessere Wärmeabfuhr.



Flank in-feed

More easily formed chip and better heat dissipation.

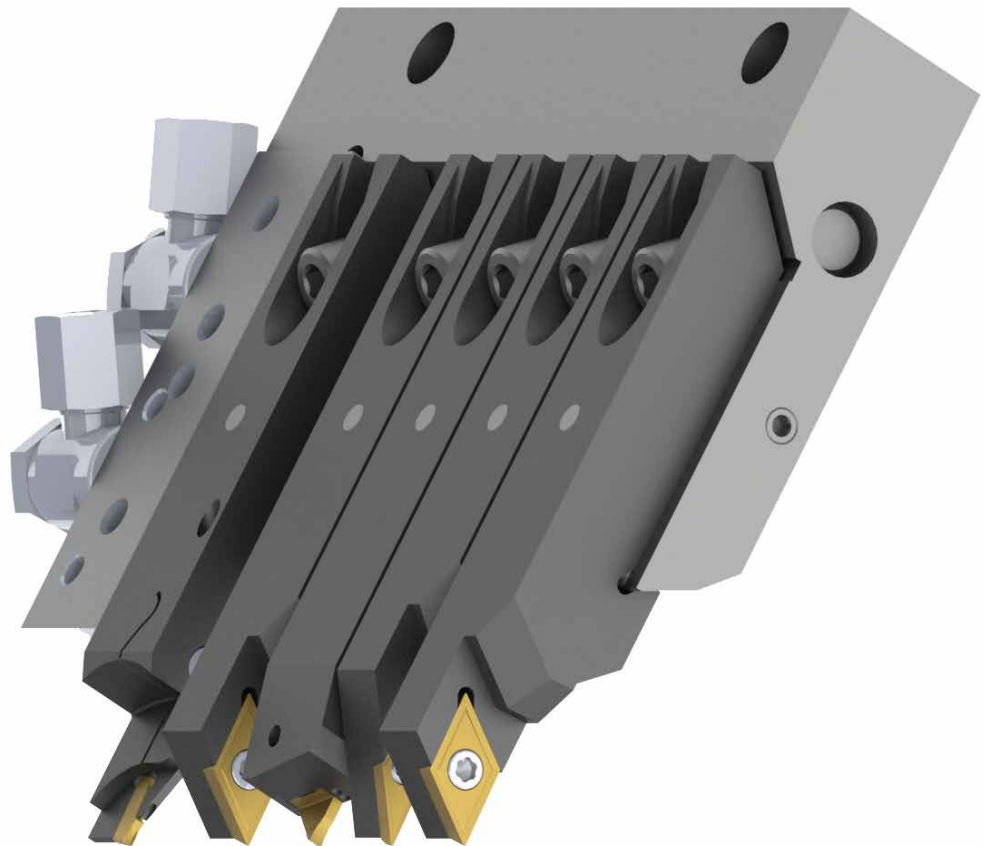

P

**Grundplatte und
Werkzeughalter**

**Base plate and
Toolholder**

GRAF[®]
WERKZEUGSYSTEME

P

Grundplatte
Basic plate
GPL

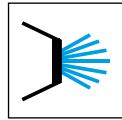

Seite/Page
587

Werkzeughalter
Toothholder
WZT

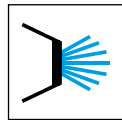

Seite/Page
588

Technische Hinweise
Technical Instructions

Seite/Page
595-590

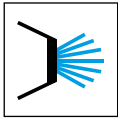

P

Bestellnummer Graf Part number Graf	Bestellnummer HORN Part number HORN	max. Werkzeuge max. toolholder	Werkzeugträger Typ Toolholder Type	Maschinentyp Type of machine
22-0200	GPL.M16.01	5	V01	CITIZEN M16
22-0290	GPL.L20.01	5	V02	CITIZEN L20
22-0400	GPL.L32.01.06	5	V03	CITIZEN L32
22-0250	GPL.SW12R11.01	5	V01	STAR SW12R11
22-0251	GPL.SW12R11.02	2	V01	STAR SW12R11
22-0275	GPL.SR20J11.01	6	V02	STAR SW12R11
22-0285	GPL.SR20R11.01	5	V02	STAR SR20R11
22-0286	GPL.SR20R11.02	2	V02	STAR SR20R11



P

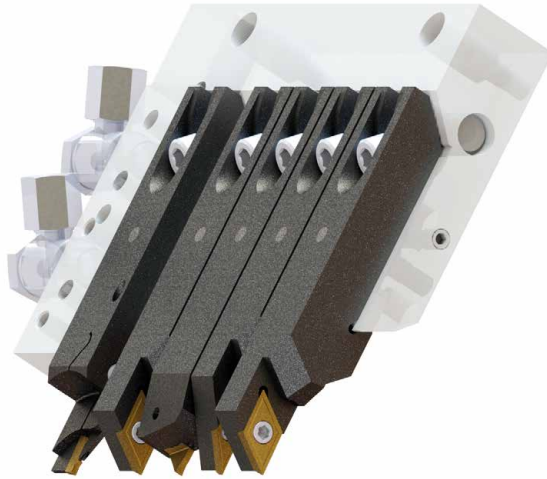

Bestellnummer Graf Part number Graf	Bestellnummer HORN Part number HORN	Ausführung Version	Schneidplatte Insert	Werkzeugträger Typ Toolholder Type
22-0202	WZT.R.V01.002.DC11	rechts/right hand	DC..11 T3..	V01
22-0208	WZT.R.V01.008.CC09	rechts/right hand	CC..09 T3..	V01
22-0206	WZT.R.V01.006.VC11	rechts/right hand	VC..11 03..	V01
22-0210	WZT.L.V01.009.VC11	links/left hand	VC..11 03..	V01
22-0215	WZTN.V01.006.VC11	neutral	VC..11 03..	V01
22-0203	WZT.R.V01.003.S100	rechts/right hand	HORN Typ S100	V01
22-0211	WZT.R.V01.010.S101	rechts/right hand	HORN Typ S101	V01
22-0212	WZT.L.V01.011.S101	links/left hand	HORN Typ S101	V01
22-0213	WZT.R.V01.012.S274	rechts/right hand	HORN Typ S274	V01
22-0214	WZT.V01.BD.01	neutral	Platzhalter/Placeholder V01	V01
22-0239	WZT.R.V02.005.DC11	rechts/right hand	DC..11 T3..	V02
22-0326	WZT.YL.V02.003.DC11	links/left hand	DC..11 T3..	V02
22-0333	WZT.R.V02.009.CC09	rechts/right hand	CC..09 T3..	V02
22-0339	WZT.R.V02.013.H105.A18	rechts/right hand	HORN Typ H105	V02
22-0330	WZTN.V02.006.VC11	neutral	VC..11 03..	V02
22-0327	WZT.R.V02.004.S101	rechts/right hand	HORN Typ S101	V02
22-0325	WZT.YL.V02.002.S274	links/left hand	HORN Typ S274	V02
22-0328	WZT.V02.BD.01	neutral	Platzhalter/Placeholder V02	V02

Werkzeugträger können für alle Wendeschneidplatten hergestellt werden.

Sonderwerkzeuge sind auf Anfrage möglich.

Toolholder can be produced for all inserts.

Special tools are available upon request.

Schnellwechselsystem Lineareinheit

Quick change system Linear unit



Beispiel STAR SW12

Example STAR SW12



P

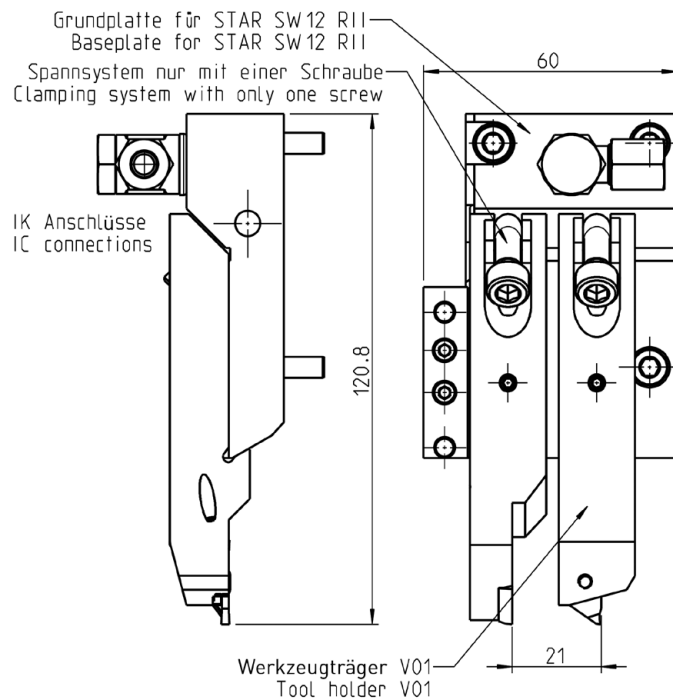
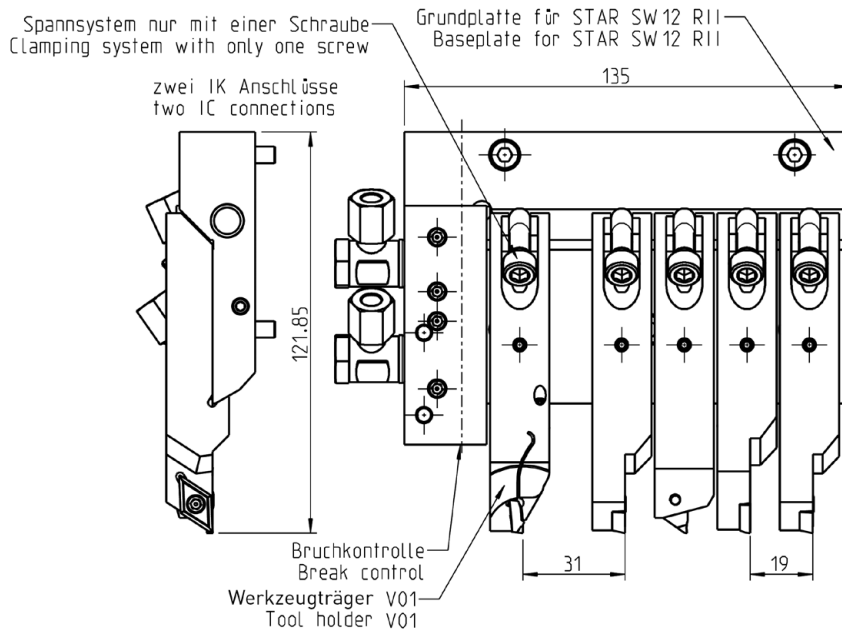

Werkzeugträger können für alle Wendeschneidplatten hergestellt werden.
Sonderwerkzeuge sind auf Anfrage möglich.
Toolholder can be produced for all inserts.
Special tools are available upon request.

Optimierte Kühltechnologie

Der Kühlmittelstrahl tritt direkt an der Schneidzone aus, der Span wird unterspült und optimal abgeführt. Der Verschleiß wird erheblich reduziert und somit die Standzeiten erhöht.

Individuelle Steuerung der Kühlmittelzufuhr sorgt für optimalen Kühlmiteleinsatz bei jedem einzelnen Werkzeugträger.

Minimierte Rüstzeiten

Das GRAF-System steht für ein einfaches Handling beim Werkzeugwechsel, somit werden die Nebenzeiten reduziert und die Produktivität erhöht.

Mit dem Einschraubsystem ist garantiert, dass der Werkzeugträger beim Werkzeugwechsel nicht herunterfällt.

Maximum an Präzisionstechnologie

Alle Werkzeugträger haben die gleiche Länge — keine zusätzliche Schnittstelle. Somit ist eine hohe Wechselgenauigkeit garantiert!

Für eine präzise Spannung der Werkzeugträger und maximale Stabilität sorgt die Schwalbenschwanz-Technologie. Die Innenkühlung erfolgt durch den Block und sorgt für eine platzsparende Lösung in der Maschine. Die kompletten Anschaffungskosten für Schläuche und Steckverbindungen entfallen.

Optimised cooling technology:

The coolant jet emerges directly at the cutting zone. The chip is flushed out and optimally removed.

Wear is considerably reduced and tool service life is increased.

Individual control of the coolant supply to each tool holder ensures optimal coolant use.

Minimised set-up times:

The GRAF system simplifies tool change, reducing non-productive times and increasing productivity.

The screw-in system guarantees that the toolholder does not fall when changing tools.

Maximum precision:

All toolholder have the same length, with no additional interface, so high precision tool change is guaranteed!

Dovetail technology ensures precise clamping of the tool carrier and maximum stability.

The coolant supply is internal through the block, ensuring a space-saving solution in the machine. The need to buy hoses and connectors is eliminated.

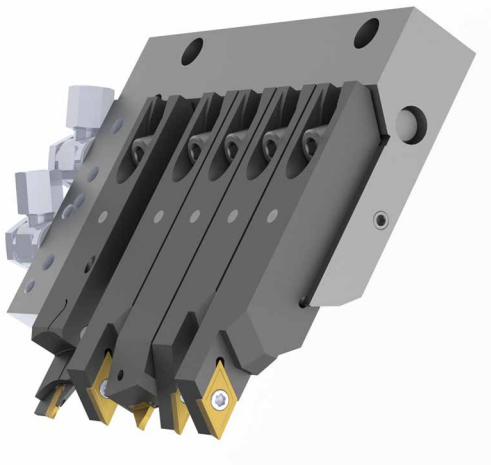

Weitere Informationen finden Sie im Graf-Katalog "HOCHLEISTUNGSWERKZEUGE".

Further information can be found in the Graf catalogue "HIGH PERFORMANCE TOOLS".

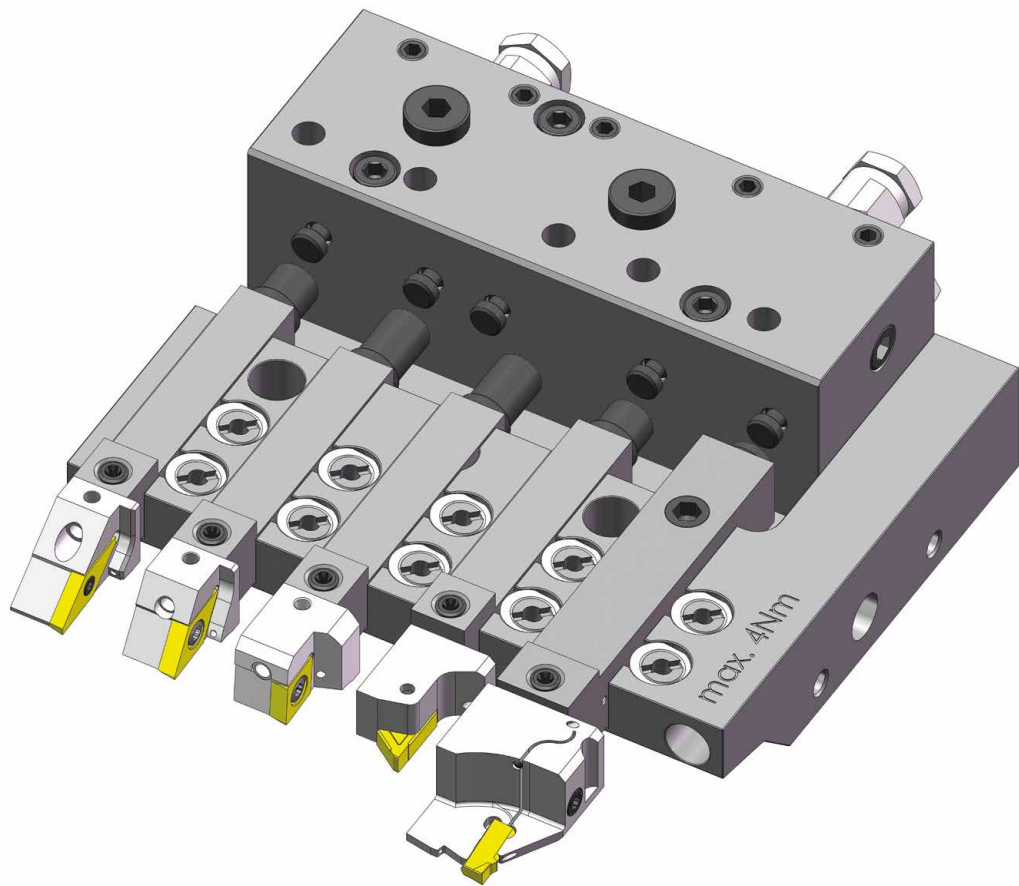

**Grundhalter für
Klemmhalter**

**Base holder
for toolholder**



Grundhalter
Basic toolholder
KH

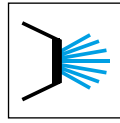

Seite/Page
593

Technische Hinweise
Technical Instructions

Seite/Page
594-597

Halter
Toolholder
WFMS

Seite/Page
598-610

Q

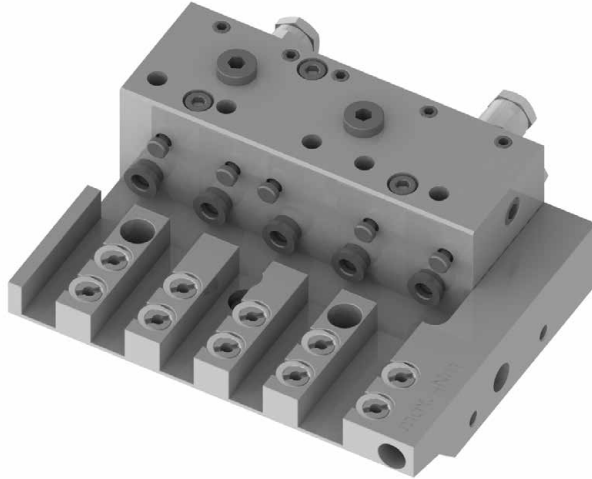

Bestellnummer Part number	Maschinentyp Machine type	Modellgruppe Modelgroup	Werkzeugplätze Tool places	Haltergröße Size of toolholder
KH.CI.AL20.1.5.1216.S	Citizen L20E-2M8/L20E-2M12/A20-3F7N	1	5	12x16
KH.CI.L32.1.6.1619.S	Citizen L32-1M8/L32-1M10/L32-1M12	1	6	16x16
KH.CI.M16.1.5.0010.S	Citizen M16-4M5/M16-4M8	1	5	10x10
KH.CI.M32.1.5.1620.S	Citizen M32-4M5/M32-4M8	3	5	16x16
KH.GS.SP20.1.6.0012.S	DMG SPRINT 20/8	1	6	12x12
KH.HA.XD2.1.6.0012.S	Hanwha XD20II/XD26II	1	6	12x12
KH.ST.SR20.1.2.0012.S	Star SR-20 RIV	1	2	12x12
KH.ST.SR20.1.5.0012.S	Star SR-20 RIV	1	5	12x12
KH.ST.SR20.2.6.0016.S	Star SR-20 JII	2	6	16x16
KH.ST.SR20.3.6.0012.S	Star SR-20 RI/SR-20 RII	4	6	12x12
KH.ST.SR20.4.6.0012.S	Star SR-20 RIII	3	6	12x12
KH.ST.SW12.1.2.0010.S	Star SW-12 RII	1	2	10x10
KH.ST.SW12.1.5.0010.S	Star SW-12 RII	1	5	10x10
KH.ST.SW20.1.2.0012.S	Star SW-20	1	42	12x12
KH.ST.SW20.1.4.0012.S	Star SW-20	1	3	12x12
KH.TS.B0126.1.3.0012.S	Tsugami B0126-III	1	3	12x12
KH.TS.B0326.1.2.0016.S	Tsugami B0326-III	1	2	16x16
KH.TS.B0326.1.5.0016.S	Tsugami B0326-III	1	5	16x16

Werkzeugträger können für alle Wendeschneidplatten hergestellt werden.
Sonderwerkzeuge sind auf Anfrage möglich.
Toolholder can be produced for all inserts.
Special tools are available upon request.



Funktionsprinzip am Beispiel Citizen L20

Functional principle using the example Citizen L20

Wirtschaftlich

Vorhandene Klemmhalter können herstellerunabhängig weiterhin eingesetzt werden. Auch Klemmhalter mit Innenkühlung sind uneingeschränkt einsetzbar.

Bedienerfreundlich

Die Lineareinheit ist 1:1 austauschbar mit der originalen Werkzeugplatte. Sicheres und schnelles Spannen durch Einhand-Spannsystem. Klemmende Keile werden automatisch gelöst.

Durchdacht

KSS-Menge ist für jede Werkzeugstation individuell einstellbar. Die Übergabe des Kühlschmierstoffes erfolgt über ein flexibles Kühlmittelrohr. Durch überwiegend glatte Flächen und einem schlauchfeien Design, wird das Bilden von Spänenestern deutlich reduziert.

Flexibel

Jede Station verfügt über einen Werkzeuganschlag, welcher von 0-15mm bzw. von 10-25mm stufenlos einstellbar ist. Der Werkzeugkamm verfügt über verschiedene Kühlmittelanschlussmöglichkeiten, welche je nach Gegebenheiten an der Maschine verwendet werden können. Die Innenkühlung kann über zwei Zuleitungen für die Werkzeuge 1-3 und 4-5 oder über eine einzelne Zuleitung für alle erfolgen.

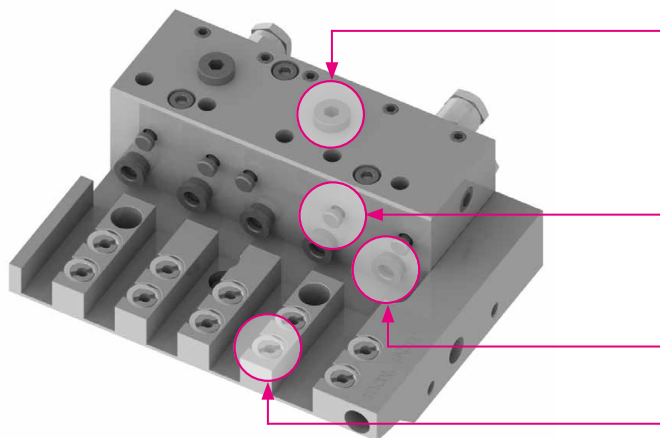

IK über 2 Zuleitungen für Werkzeug 1-3 / 4-5 oder über eine einzelne Zuleitung alle zusammen

KSS-Menge individuell für jedes Werkzeug einstellbar

Werkzeuganschlag 0-15 mm / 10-25 mm stufenlos einstellbar

Einhand-Spannsystem - Klemmende Keile werden automatisch gelöst

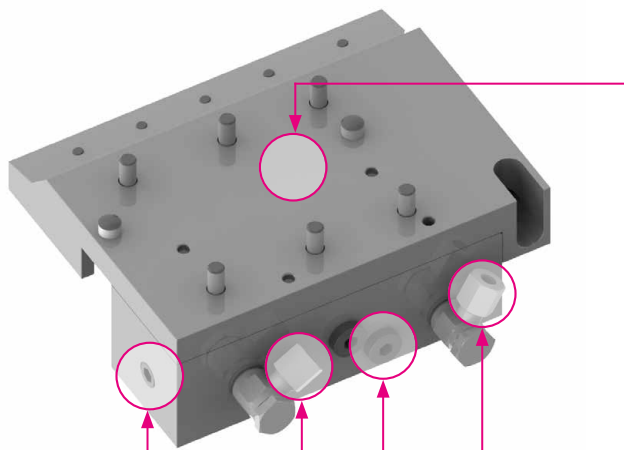

1:1 austauschbar mit der originalen Werkzeugplatte

Verschiedene KM-Anschlussmöglichkeiten je nach Gegebenheit der Maschine



Funktionsprinzip am Beispiel Citizen L20

Functional principle using the example Citizen L20

Economically

Already existing turning holders can still be used regardless of the manufacturer. Turning holders with IC can also be used with internal cooling without any restriction.

User-friendly

The linear unit is 1:1 interchangeable with the original tool plate. Safe and fast clamping with one-hand clamping system. Clamping wedges are automatically released.

Smart

Coolant quantity is individually adjustable for each tool station. The transfer of the cooling lubricant takes place via a flexible coolant pipe. Due to the mainly smooth surfaces and the hose free design, the formation of chip nests is significantly reduced.

Flexible

Each station has a tool stop, which is infinitely adjustable from 0-15 mm or from 10-25 mm. Linear unit has various coolant connection options, which can be used depending on the conditions on the machine. The internal cooling can be done via two supply lines for tools 1-3 and 4-5 or via a single supply line for all.

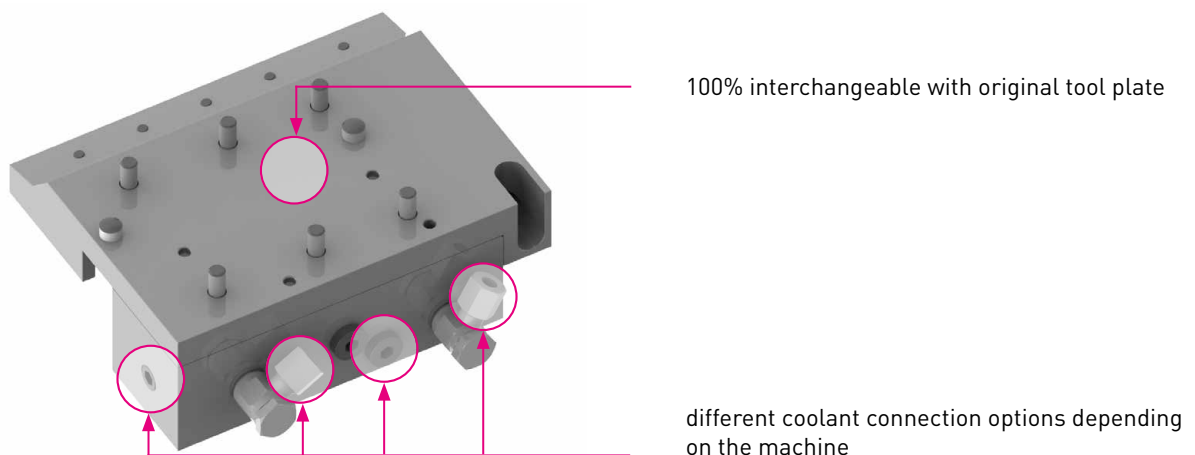
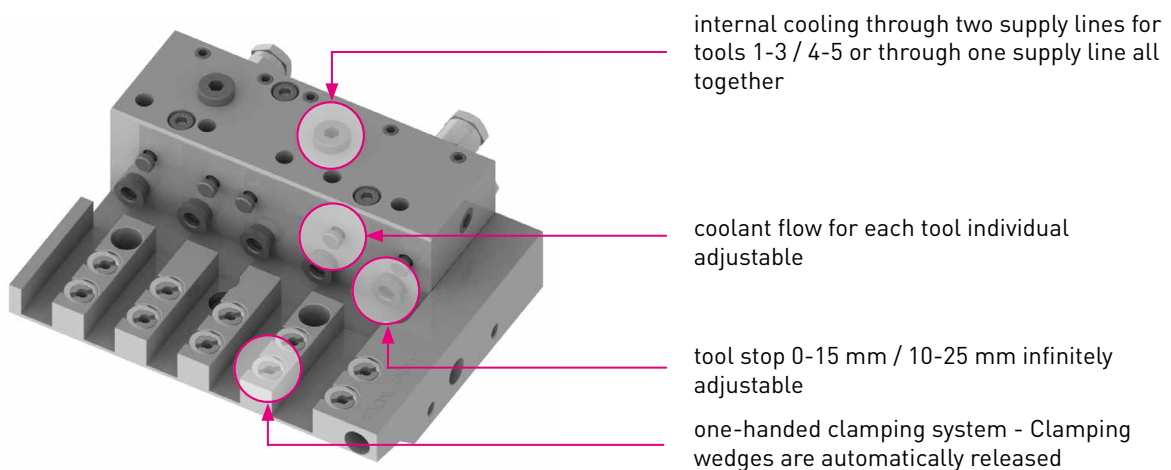



Einsparpotential durch WF-MICRO

Savings potential through WF-MICRO

Q

WF-Micro – das innovative modulare Adaptersystem für statische Werkzeuge auf allen gängigen Langdrehmaschinen und Mehrspindeldrehautomaten, das Ihnen eine bis dato unerreichbare Produktivität ermöglicht.

Der Wechsel der Wendeschneidplatten ist oft durch die Bauweise der Maschinen nur bedingt möglich. Meist müssen die kompletten Grundhalter ausgebaut werden. Dies ist sehr zeitaufwändig und führt zu hohen Stillstandszeiten.

Das gehört jetzt der Vergangenheit an.

Die modularen WF-Micro Halter sind in den Ausführungen 10x10, 12x12, 16x16 und 3/8"x3/8", 1/2"x1/2", 5/8"x5/8" lieferbar.

- Grundhalter mit integriertem Kühlmittelanschluss ermöglichen den Einsatz auf jeder möglichen Position in der Maschine.
- Die einfache Einhandbedienung erlaubt einen sicheren und einfachen Wechsel der Wendeschneidplattenadapter.
- Sämtliche Adapter können außerhalb der Maschine voreingestellt und vermessen werden.
- Der Werkzeugwechsel erfolgt innerhalb weniger Sekunden.
- Die Rüst- und Nebenzeiten werden auf ein Minimum reduziert und die Produktivität Ihrer Maschine auf ein Maximum gesteigert.
- Die Konzeption der Schnittstelle als Kurzkegel mit Plananlage und zylindrischer Abstützung garantiert eine exakte Lagepositionierung und Genauigkeit im einstelligen μ -Bereich.
- Die schwingungsdämpfende Eigenschaft der WF-Micro Schnittstelle ergibt deutlich bessere Bearbeitungsergebnisse und längere Standzeiten der Wendeschneidplatten.

Nutzen Sie die Vorteile von WF-Micro und steigern Sie ihre Produktivität.

WF-Micro - the innovative modular adapter system for static tools on all common sliding head lathes and multi-spindle automatic lathes, which enables you to achieve previously unattainable productivity.

Changing the indexable inserts is often only possible to a limited extent due to the design of the machines. In most cases, the complete basic holder must be removed. This is very time-consuming and leads to long downtimes.

That is now a thing of the past.

The modular WF-Micro holders are available in the versions 10x10, 12x12, 16x16 and 3/8"x3/8", 1/2"x1/2", 5/8"x5/8".

- Basic brackets with integrated coolant connection allow the tool to be used at any possible position in the machine.
- The simple one-hand operation allows for a safe and easy change of the insert adapter.
- All adapters can be preset and measured outside the machine.
- The tool change takes place within seconds.
- The set-up and off-times are reduced to a minimum and the productivity of your machine is increased to a maximum.
- The conception of the interface as a short cone with a planar system and cylindrical support guarantees an exact positioning and accuracy in the single-digit μ -range.
- The vibration-damping property of the WF-Micro interface results in significantly better processing results and longer service life of the insert.

Take advantage of WF-Micro and increase your productivity.

Gebrauch und Wartung

Handling and maintenance



Hinweis zur Befestigung

Zunächst einen Kegelgewindestift unter Verwendung eines Drehmoment-Schraubendrehers anziehen, dabei 1-2 mal lösen und wieder anziehen. Dadurch wird eine optimale Positionierung der Bauteile erreicht. Der 2. Kegelgewindestift wird nun ebenfalls(wie oben angeführt) angezogen.

Empfohlenes Anzugsdrehmoment beträgt beim WFM-System: 4 Nm.

Pflege und Wartung

Die Oberfläche der Planflächen, der Kegelbohrung und Kegelzapfen sind vor Gebrauch zu reinigen und mit einem Öl-Schmierfilm zu versehen. Um eine optimale Befestigung und Lösbarkeit der Kegelgewindestifte zu erreichen, wird empfohlen die Kegelgewindestifte mit z.B. Molykote 1000 oder einer ähnlichen Heiss-Schraubenpaste zu behandeln.

Advice for fixing

First tighten one threaded pin, in doing so 1 or 2 times unscrew and tighten again. Thereby you get an optimum positioning of the components. The second threaded taper pin you will tighten with the same method.

Recommended locking torque for the WFM System is 4 Nm.

Support and maintenance

The surface of the face, the cone drill and cone pin must be cleaning and lubricate with oil before using. To reach an optimum fixing and resolvability of the threaded taper pins, are recommended to use for example Molykote 1000 or something similar.

Funktionsprinzip

Function

Vorteile des WF-Micro Systems

- Einfache Bedienung (nur eine Klemmschraube)
- Garantierte Lagefixierung beim Fügen
- Höchste Präzision und Steifigkeit durch patentiertes Kegel-Plananlage-System mit zyl. Abstützung
- Ausserhalb der Maschine voreinstellbar

Advantages of the WF-Micro system

- simple handling (only one screw)
- guaranteed positioning
- highest precision and stiffness through patented taper and face system cylindrical stabilizer
- adjustment outside the machine

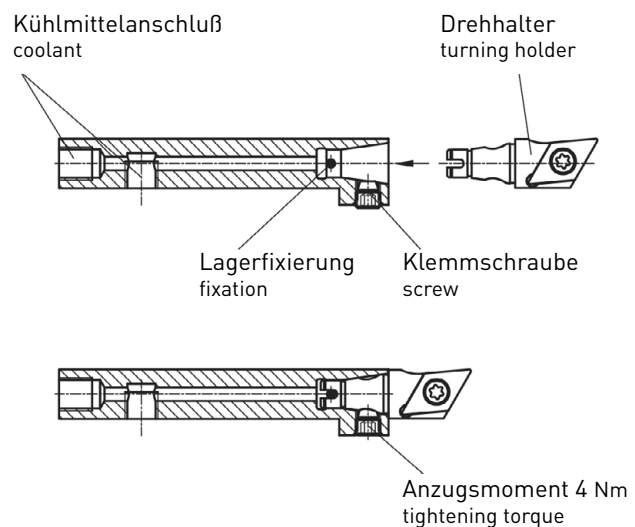



Q

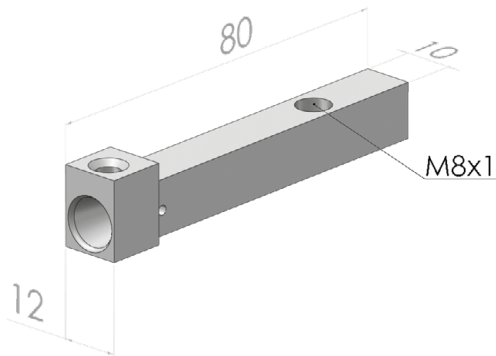

Statischer Halter 8x8VKT mit IKZ
 Static holder with internal cooling
Bestellnummer **WFMS.VKT.010.IK**
 Order no.

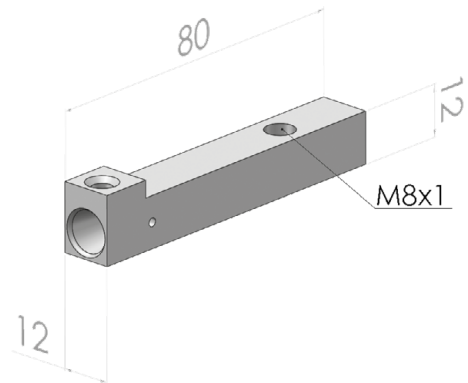

Statischer Halter 12x12VKT mit IKZ
 Static holder with internal cooling
Bestellnummer **WFMS.VKT.012.IK**
 Order no.

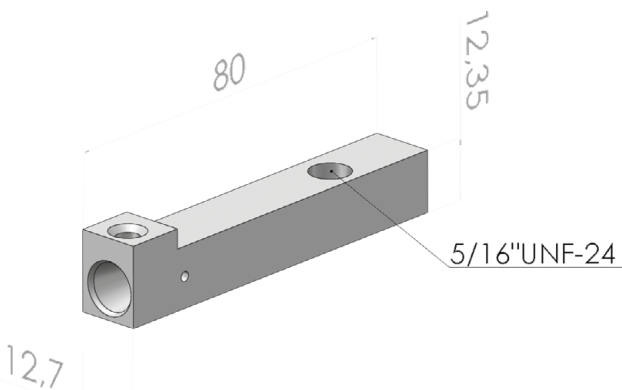

Statischer Halter 12,7x12,7VKT mit IKZ
 Static holder with internal cooling
Bestellnummer **WFMS.VKT.012,7.IK**
 Order no.

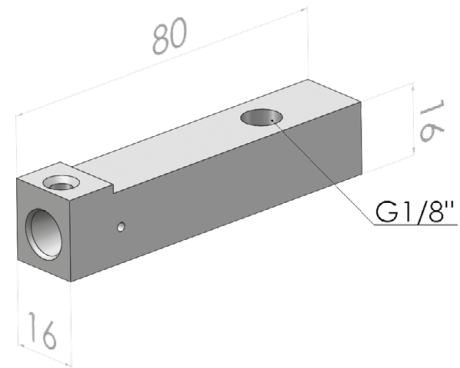

Statischer Halter 16x16VKT mit IKZ
 Static holder with internal cooling
Bestellnummer **WFMS.VKT.016.IK**
 Order no.

WFMS - modulare Drehhalter ISO C Typ

WFMS - modular turning holders ISO C type

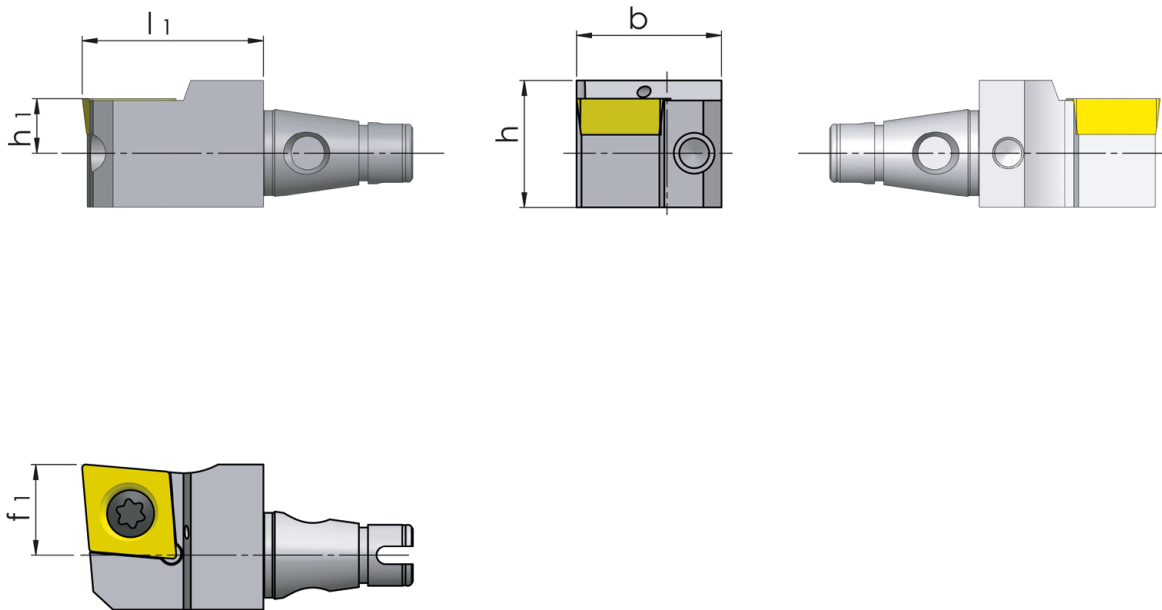

fits for holder	[mm]	[mm]	[mm]	[mm]	[mm]	Order no.
passend für Halter	h	b	l1	h1	f1	Bestellnummer
10x10, 12x12, 1/2"x1/2"	14	16	20	6	6	WF.M.12.SCLCL.09.IK
10x10, 12x12, 1/2"x1/2"	14	16	20	6	6	WF.M.12.SCLCR.09.IK
16x16	20	18	20	8	8	WF.M.16.SCLCL.09.IK
16x16	20	18	20	8	8	WF.M.16.SCLCR.09.IK

WFMS - modulare Drehhalter ISO D Typ

WFMS - modular turning holders ISO D type



Q

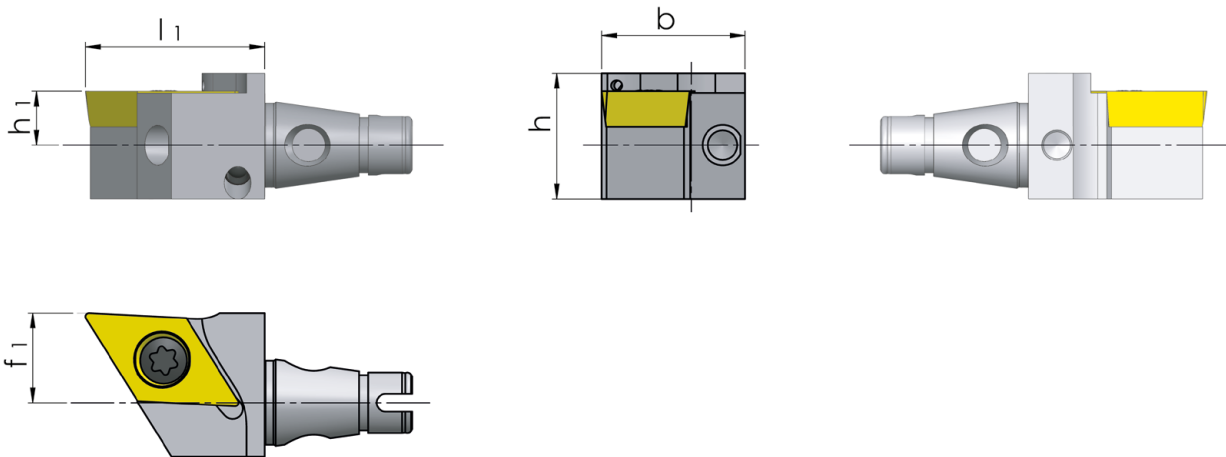

fits for holder	[mm]	[mm]	[mm]	[mm]	[mm]	Order no.
passend für Halter	h	b	l1	h1	f1	Bestellnummer
10x10, 12x12, 1/2"x1/2"	14	16	20	6	6	WF.M.12.SDJCL.11.IK
10x10, 12x12, 1/2"x1/2"	14	16	20	6	6	WF.M.12.SDJCR.11.IK
10x10, 12x12, 1/2"x1/2"	14	16	25	6	0	WF.M.12.SDNCN.11.IK
16x16	18	18	20	8	8	WF.M.16.SDJCL.11.IK
16x16	18	18	20	8	8	WF.M.16.SDJCR.11.IK

WFMS - modulare Drehhalter ISO V Typ

WFMS - modular turning holders ISO V type

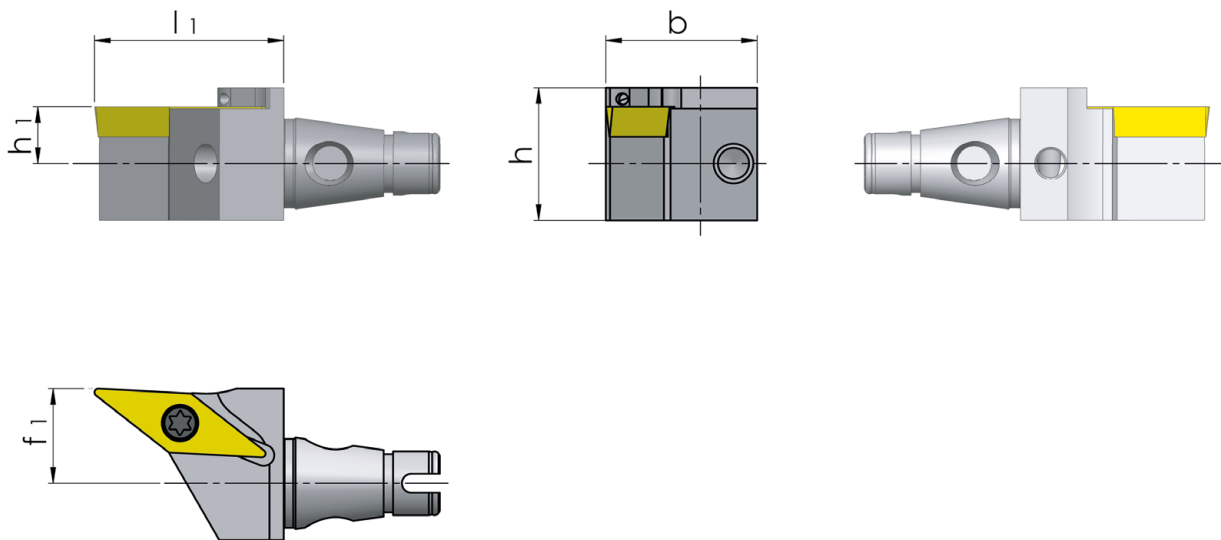

fits for holder	[mm]	[mm]	[mm]	[mm]	[mm]	Order no.
passend für Halter	h	b	l1	h1	f1	Bestellnummer
10x10, 12x12, 1/2"x1/2"	14	16	20	6	6	WF.M.12.SVJCL.11.IK
10x10, 12x12, 1/2"x1/2"	14	16	20	6	6	WF.M.12.SVJCR.11.IK
10x10, 12x12, 1/2"x1/2"	15	16	25	6	0	WF.M.12.SVVCN.11.IK
10x10, 12x12, 1/2"x1/2"	14	16	25	6	10	WF.M.12.SVJCL.13.IK
10x10, 12x12, 1/2"x1/2"	14	16	25	6	6	WF.M.12.SVJCR.13.IK
16x16	18	18	20	8	8	WF.M.16.SVJCL.11.IK
16x16	18	18	20	8	8	WF.M.16.SVJCR.11.IK

WFMS - modulare Drehhalter HORN H100

WFMS - modular turning holders HORN H100

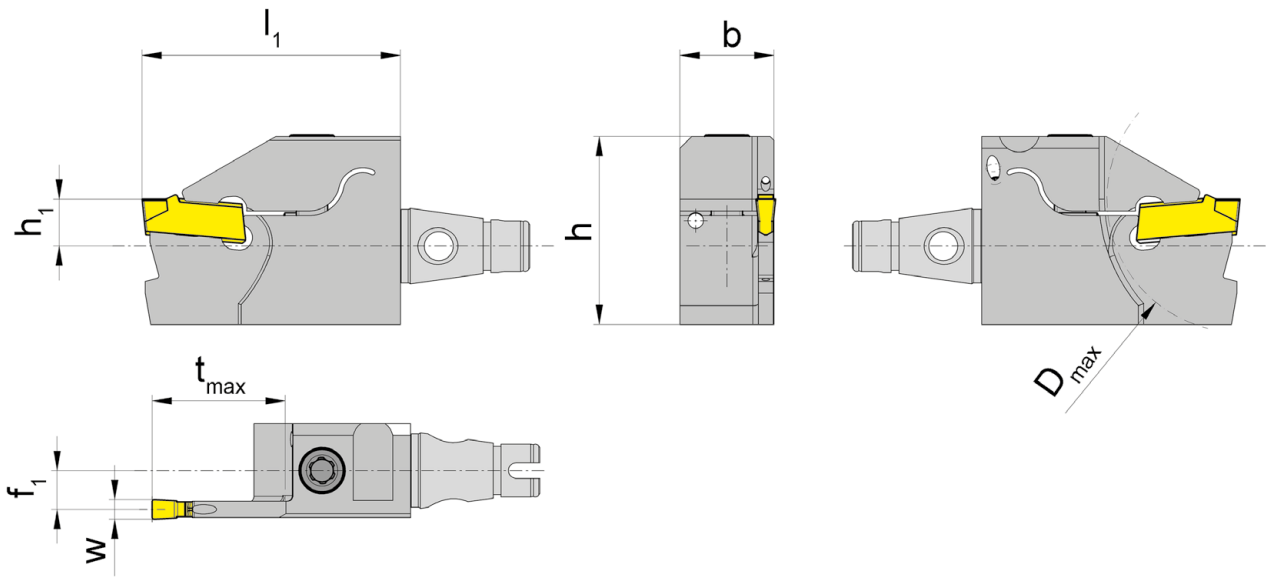

fits for holder	[mm]	[mm]	[mm]	[mm]	[mm]	[mm]	[mm]	[mm]	[mm]	Order no.
passend für Halter	h	b	l1	h1	f1	tmax	Dmax	w	Größe	Bestellnummer
10x10, 12x12, 1/2"x1/2"	24	12	33	6	5,2	17	34	2	01	WF.M.12.R100.4.41.IK
10x10, 12x12, 1/2"x1/2"	24	12	33	6	4,95	17	34	2,5	02	WF.M.12.R100.4.42.IK
10x10, 12x12, 1/2"x1/2"	24	12	33	6	4,75	17	34	3	03	WF.M.12.R100.4.43.IK
16x16	26	16	33	8	7,2	17	34	2	01	WF.M.16.R100.4.41.IK
16x16	26	16	33	8	6,95	17	34	2,5	02	WF.M.16.R100.4.42.IK
16x16	26	16	33	8	6,75	17	34	3	03	WF.M.16.R100.4.43.IK

Spare Parts

Ersatzteile

Screw	Clamp	TORX PLUS Wrench	For torque specification Nm	Toolholder
Spannschraube	Spannelement	TORX PLUS-Schlüssel	Das Anzugsmoment der Schrauben ist Nm.	Klemmhalter
4.20T15P		T15PL	4,3	WF.M.1...R100...IK

WFMS - modulare Drehhalter HORN H224

WFMS - modular turning holders HORN H224

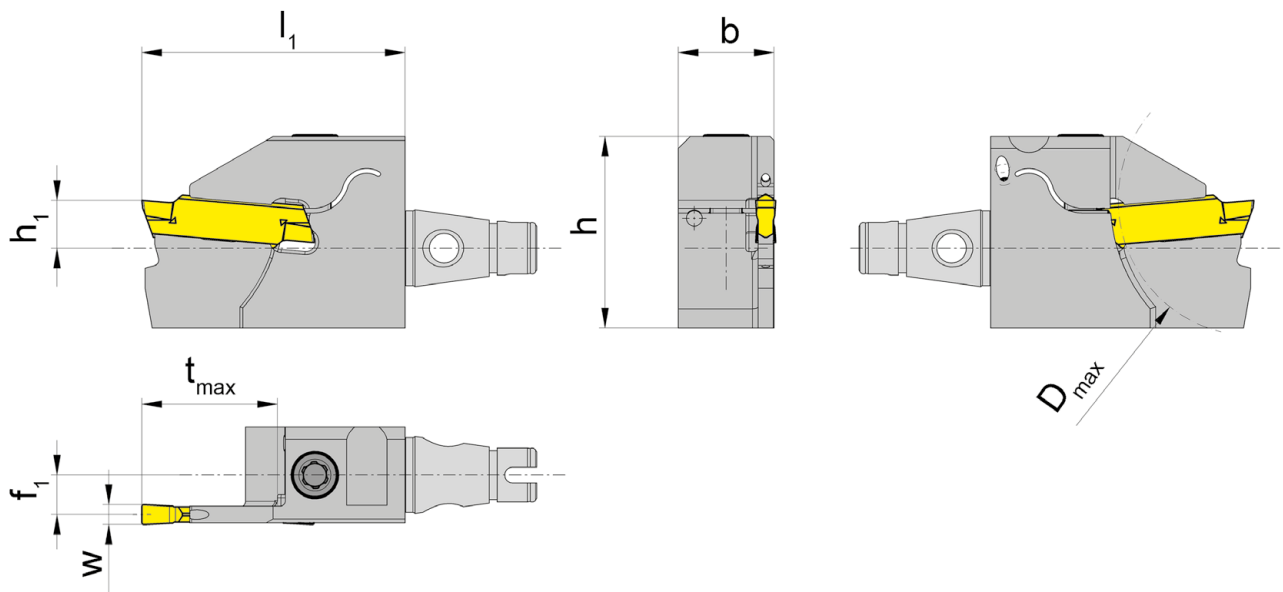

fits for holder	[mm]	[mm]	[mm]	[mm]	[mm]	[mm]	[mm]	[mm]		Order no.
passend für Halter	h	b	l1	h1	f1	tmax	Dmax	w	Größe	Bestellnummer
10x10, 12x12, 1/2"x1/2"	24	12	33	6	5,2	17	34	2	01	WF.M.12.R224.4.41.IK
10x10, 12x12, 1/2"x1/2"	24	12	33	6	4,95	17	34	2,5	02	WF.M.12.R224.4.42.IK
10x10, 12x12, 1/2"x1/2"	24	12	33	6	4,75	17	34	3	03	WF.M.12.R224.4.43.IK
16x16	26	16	33	8	7,2	17	34	2	01	WF.M.16.R224.4.41.IK
16x16	26	16	33	8	6,95	17	34	2,5	02	WF.M.16.R224.4.42.IK
16x16	26	16	33	8	6,75	17	34	3	03	WF.M.16.R224.4.43.IK

Spare Parts

Ersatzteile

Screw	Clamp	TORX PLUS Wrench	For torque specification Nm	Toolholder
Spannschraube	Spannelement	TORX PLUS-Schlüssel	Das Anzugsmoment der Schrauben ist Nm.	Klemmhalter
4.20T15P		T15PL	4,3	WF.M.1...R224...IK

WFMS - modulare Drehhalter HORN H264

WFMS - modular turning holders HORN H264

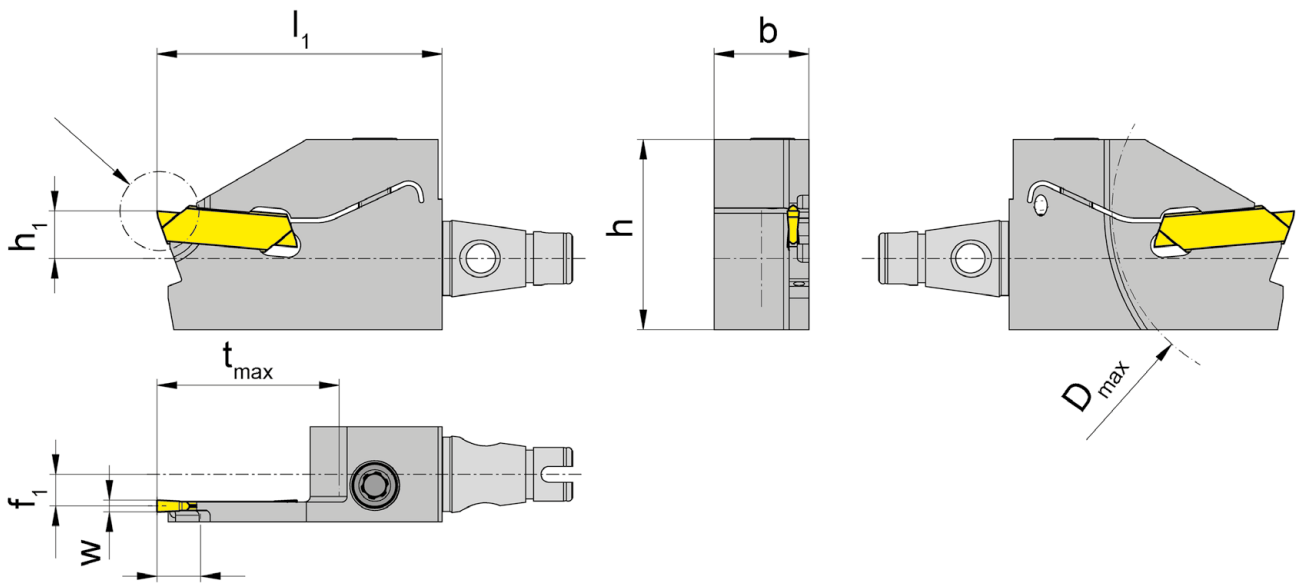

Q

fits for holder	[mm]	[mm]	[mm]	[mm]	[mm]	[mm]	[mm]	[mm]		Order no.
passend für Halter	h	b	l1	h1	f1	tmax	Dmax	w	Größe	Bestellnummer
10x10, 12x12, 1/2"x1/2"	24	12	36	6	4	5,5	10	1,5	01	WF.M.12.R264.1.51.IK
16x16	23	16	36	8	6	5,5	10	1,5	01	WF.M.16.R264.1.51.IK

Spare Parts

Ersatzteile

Screw	Clamp	TORX PLUS Wrench	For torque specification Nm	Toolholder
Spannschraube	Spannelement	TORX PLUS-Schlüssel	Das Anzugsmoment der Schrauben ist Nm.	Klemmhalter
4.20T15P		T15PL	4,3	WF.M.1...R264.1.51.IK

WFMS - modulare Drehhalter HORN H274

WFMS - modular turning holders HORN H274

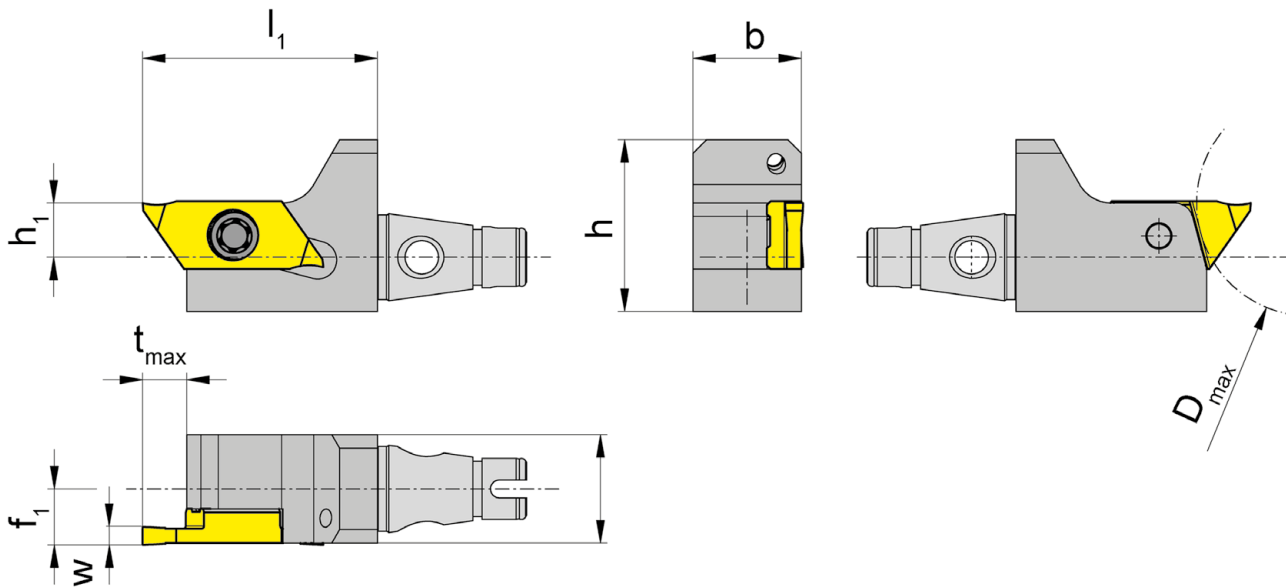

fits for holder	[mm]	[mm]	[mm]	[mm]	[mm]	[mm]	[mm]	[mm]		Order no.
passend für Halter	h	b	l1	h1	f1	tmax	Dmax	w	Größe	Bestellnummer
10x10, 12x12, 1/2"x1/2"	19	12	26	6	6,2	6	25	04	01	WF.M.12.R274.2.24.IK
16x16	23	16	26	8	8,2	6	25	04	02	WF.M.16.R274.2.24.IK

Spare Parts

Ersatzteile

Screw	Clamp	TORX PLUS Wrench	For torque specification Nm	Toolholder
Spannschraube	Spannelement	TORX PLUS-Schlüssel	Das Anzugsmoment der Schrauben ist Nm.	Klemmhalter
030.3509.T15P		T15PQ	3,0	WF.M.1...R274.2.24.IK



WFMS - modulare Drehhalter HORN H356

WFMS - modular turning holders HORN H356

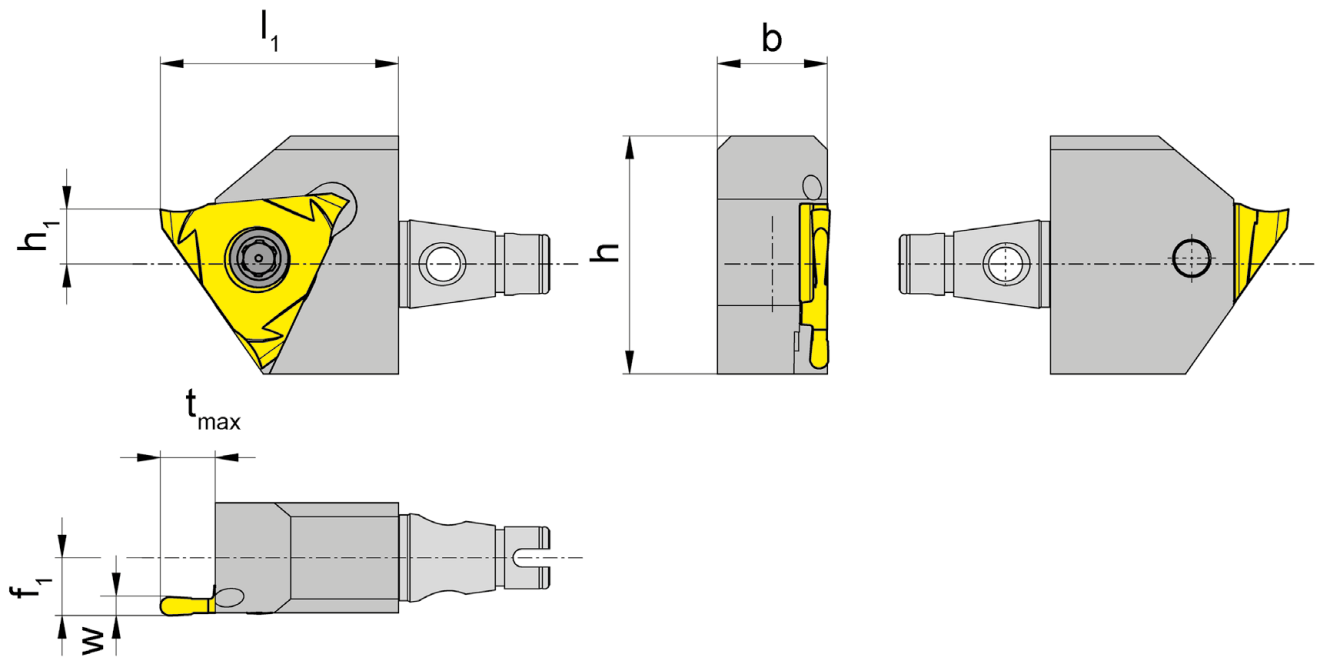

fits for holder	[mm]	[mm]	[mm]	[mm]	[mm]		Order no.
passend für Halter	h	b	l1	h1	f1	Größe	Bestellnummer
10x10, 12x12, 1/2"x1/2"	26	12	26	6	6,3	03	WF.M.12.R356.1.23.IK
16x16	26	16	26	8	8,3	03	WF.M.16.R356.1.23.IK

Spare Parts

Ersatzteile

Screw	Clamp	TORX PLUS Wrench	For torque specification Nm	Toolholder
Spannschraube	Spannelement	TORX PLUS-Schlüssel	Das Anzugsmoment der Schrauben ist Nm.	Klemmhalter
030.500P.0232		T20PQ	6,0 - 6,5	WF.M.12.R356.1.23.IK
5.12T20P		T20PQ	6,0 - 6,5	WF.M.16.R356.1.23.IK

WFMS - modulare Drehhalter HORN H360

WFMS - modular turning holders HORN H360

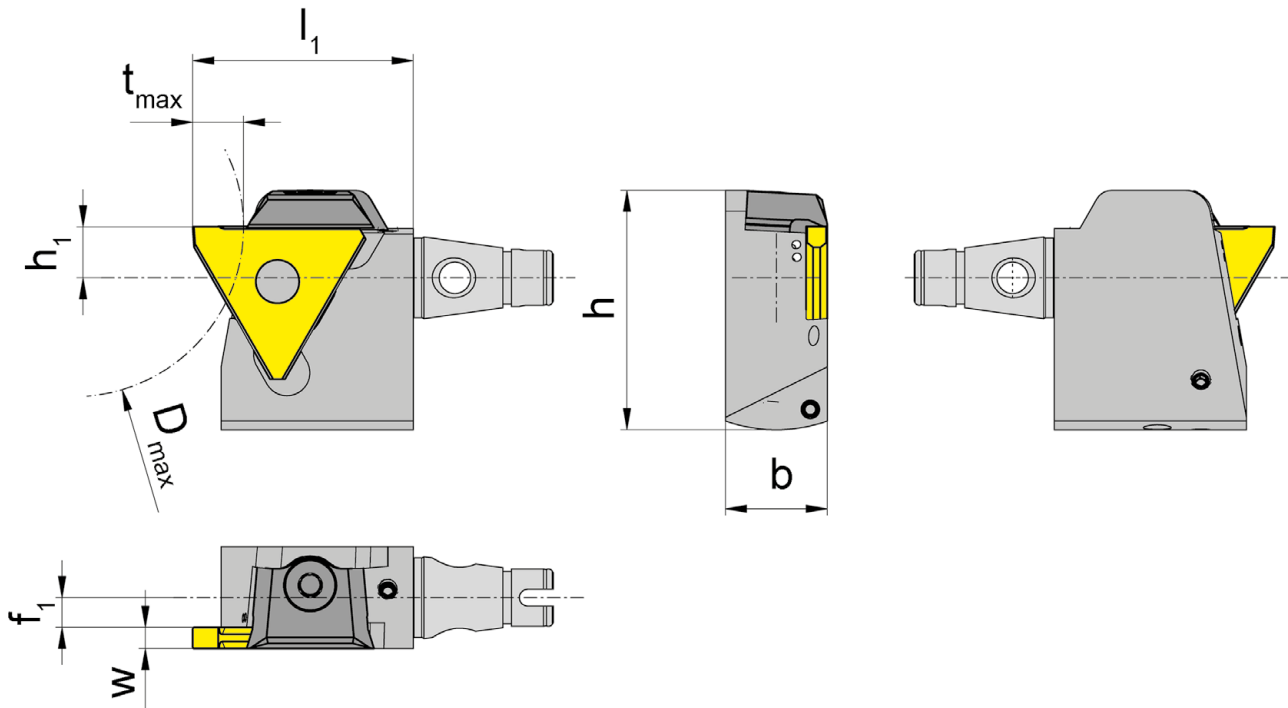

fits for holder	[mm]	[mm]	[mm]	[mm]	[mm]	[mm]	[mm]	[mm]		Order no.
passend für Halter	h	b	l1	h1	f1	tmax	Dmax	w	Größe	Bestellnummer
10x10, 12x12, 1/2"x1/2"	28,2	12	26	6	4,5	4	40	0,5 - 1,9	01	WF.M.12.R360.1.51.IK
10x10, 12x12, 1/2"x1/2"	28,2	12	26	6	3,5	6	40	1,9 - 2,9	02	WF.M.12.R360.2.52.IK
10x10, 12x12, 1/2"x1/2"	28,2	12	26	6	2,5	6	40	2,9 - 3,9	03	WF.M.12.R360.2.53.IK
16x16	30,2	16	26	8	6,5	4	40	0,5 - 1,9	01	WF.M.16.R360.1.51.IK
16x16	30,2	16	26	8	5,5	6	40	1,9 - 2,9	02	WF.M.16.R360.2.52.IK
16x16	30,2	16	26	8	4,5	6	40	2,9 - 3,9	03	WF.M.16.R360.2.53.IK

Spare Parts

Ersatzteile

Screw	Clamp	TORX PLUS Wrench	For torque specification Nm	Toolholder
Spannschraube	Spannelement	TORX PLUS-Schlüssel	Das Anzugsmoment der Schrauben ist Nm.	Klemmhalter
	12.3	T10PL	3,0	WF.M.1...R360...IK

WFMS - modulare Drehhalter HORN 106-11P

WFMS - modular turning holders HORN 106-11P

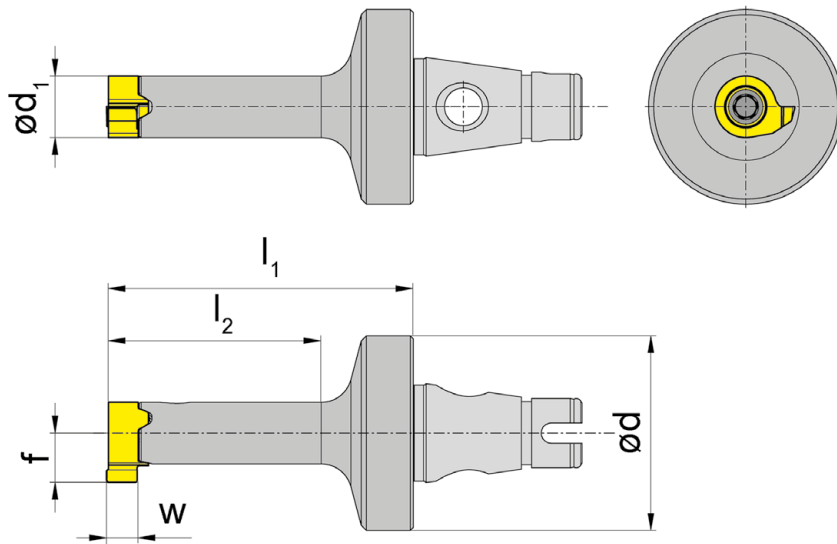

fits for holder	[mm]	[mm]	[mm]	[mm]	Order no.
passend für Halter	d	d1	l1	l2	Bestellnummer
Ø 19,05-28	19	4,4	17	8,5	WF.M.RB106.00.IK
Ø 19,05-28	19	5,2	19	10	WF.M.RB107.00.IK
Ø 19,05-28	19	6	21,5	12,5	WF.M.B108.00.IK
Ø 19,05-28	19	6	30	21	WF.M.B108.01.IK
Ø 19,05-28	19	6	21	12,5	WF.M.RB10P.00.IK
Ø 19,05-28	19	8	26	16,5	WF.M.B111.00.IK
Ø 19,05-28	19	8	38,5	29	WF.M.B111.01.IK
Ø 19,05-28	19	7	24	15	WF.M.RB11P.00.IK

Spare Parts

Ersatzteile

Screw	Clamp	TORX PLUS Wrench	For torque specification Nm	Toolholder
Spannschraube	Spannelement	TORX PLUS-Schlüssel	Das Anzugsmoment der Schrauben ist Nm.	Klemmhalter
1.8.4TEP		T6PL	0,9	WF.M.RB106.00.IK
2.2.5T7EP	010.0105.03	T7PL	1,1	WF.M.RB107.00.IK
2.6.5T8EP	010.0105.04	T8PL	1,2	WF.M.B108.00.IK / ..B10P../..
3.5.12T10EP	010.0105.05	T10PL	3	WF.M.B111.00.IK
3.10T9P		T9PL	1,8	WF.M.RB11P.00.IK

WFMS - modulare Drehhalter HORN 105-110

WFMS - modular turning holders HORN 105-110

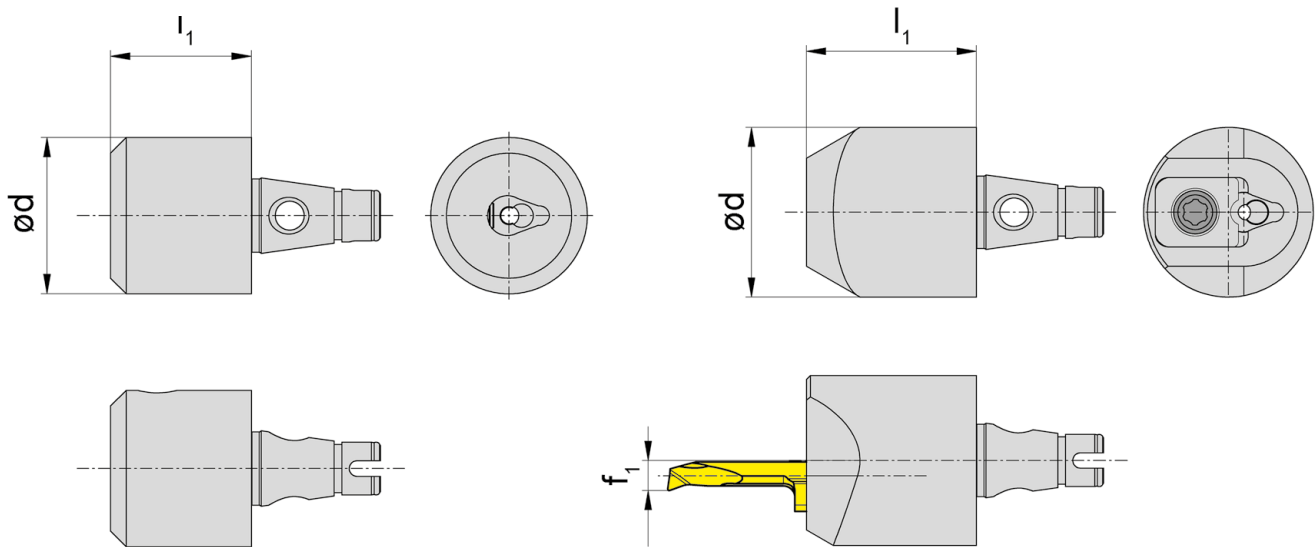

fits for holder	[mm]	[mm]	[mm]	[mm]	Order no.
passend für Halter	d	l1	f1	*b	Bestellnummer
Ø 19,05-28	20	18	-	-	WF.M.B105.IK
Ø 19,05-28	22	30	-	-	WF.M.B110.IK
Ø 19,05-28	22	22	3,3	5,9	WF.M.B105.S.03.IK
Ø 19,05-28	22	22	3,9	6,4	WF.M.B105.S.04.IK
Ø 19,05-28	21	22	5,3	7,0	WF.M.B105.S.05.IK

*b = Schneidplattenhöhe

*b = Height of insert

Spare Parts

Ersatzteile

Screw	Clamp	TORX PLUS Wrench	For torque specification Nm	Toolholder
Spannschraube	Spannelement	TORX PLUS-Schlüssel	Das Anzugsmoment der Schrauben ist Nm.	Klemmhalter
6.075T15P		T15PQ	5	WF.M.B105.IK / WF.M.B110.IK
	010.0105.03	T15PL	2	WF.M.B105.S.03.IK
	010.0105.04	T15PL	2	WF.M.B105.S.04.IK
	010.0105.05	T15PL	2	WF.M.B105.S.05.IK



Q

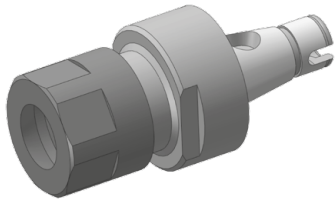

Drehhalter Typ ER11
Turning holder type ER11

Bestellnummer Part Number WFMS.E11.025.M

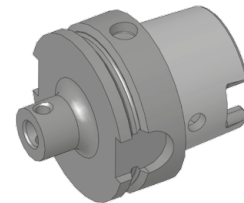

Drehhalter Grundhalter HSK63
Turning holder basic holder HSK63

Bestellnummer Part Number WFMS.020.H63

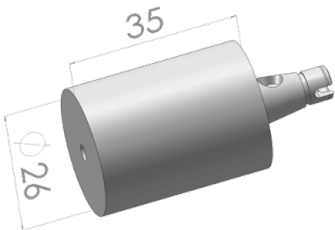

Drehhalter Rohling \varnothing 26
Turning holder blank \varnothing 26

Bestellnummer Part Number WFMS.R.D26x35

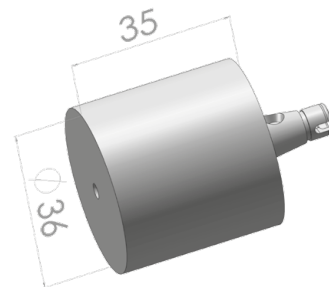

Drehhalter Rohling \varnothing 36
Turning holder blank \varnothing 36

Bestellnummer Part Number WFMS.R.D36x35

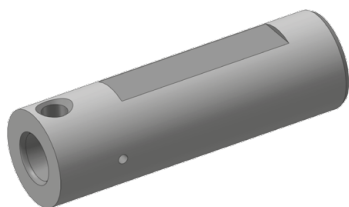

Drehhalter Rundschaft
Turning holder cylindrical

Bestellnummer Part Number WFMS.RS.20.065.IK

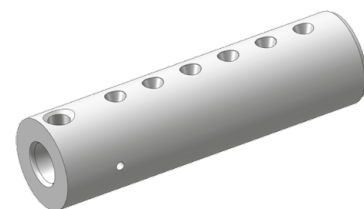

Drehhalter Rundschaft
Turning holder cylindrical

Bestellnummer Part Number WFMS.RS.22.080.IK

Weitere Informationen finden Sie im Katalog „MODULARE LANGDREHTECHNIK“.
Further informations can be found in the catalogue „MODULAR TECHNOLOGY FOR SWISS TYPE MACHINES“.



Q

Q

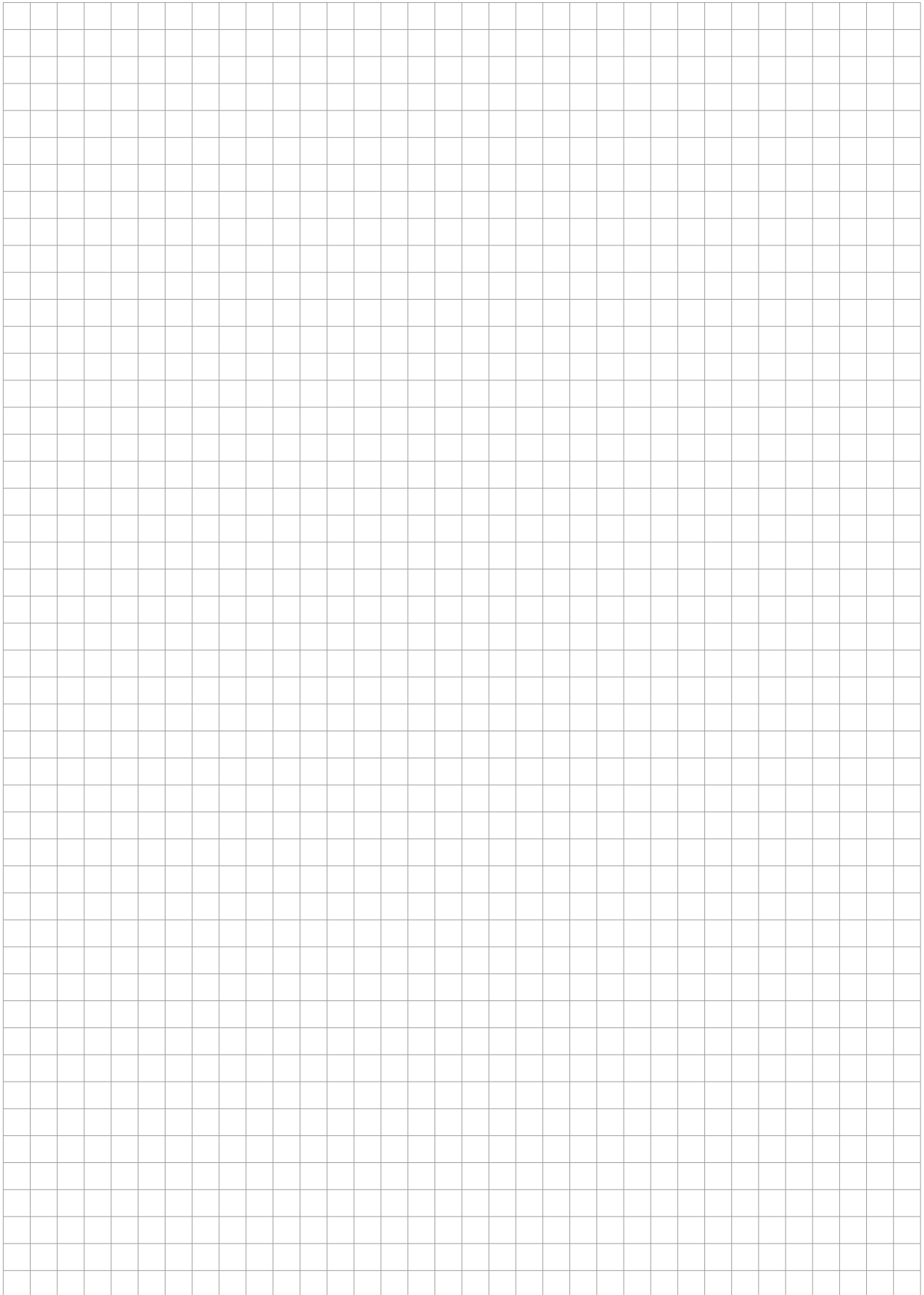



Inhalt/Summary	Seite/Page
Übersicht	614-615
Overview	
Monoblock	616-621
Monobloc	
Modular	622-626
Modular	
JET-Wirbeln	628-633
JET Whirling	
HORN Turbowirbeln	635-636
HORN Turbowhirling	
High-Speed-Wirbeln	637-638
High-Speed-Whirling	
Technische Hinweise	639-644
Technical Instructions	

Monoblock Systeme

Einteilige Gewindewirbelköpfe mit maximaler Präzision und Stabilität für alle gängigen Gewindewirbelapparate.

Modulare Gewindewirbelsysteme

Zweiteiliges System mit Grundkörper und Ringkassette für höchste Wechselgenauigkeit. Einfaches Handling bedeutet kürzeste Rüstzeiten.

JET-Wirbeln

Das einzige Werkzeug auf dem Markt mit Innenkühlung direkt auf die Schneide. Dies garantiert die Vermeidung von Spänestau und damit höchste Standzeiten und Oberflächengüten, bei sehr hohen Wechselgenauigkeiten.

HORN Turbowirbeln®

Optimierter Zerpanungsprozess durch Schnittaufteilung. Höhere Schnittdaten und die Vermeidung von Spänestau, die Standzeiten erhöhen sich signifikant.

High-Speed-Wirbeln

Die neue Technologie für kürzere Bearbeitungszeiten bietet hohe Produktivität durch parallele Dreh- und Wirbelbearbeitung. Das High-Speed-Wirbeln erfolgt mit unserem Maschinen- und Prozesstechnologiepartner Index / Traub.

Monobloc Systems

Monobloc thread whirling heads with maximum precision and stability for all common thread whirling units.

Modular Thread Whirling Systems

Two-part system with basic body and ring cassette for maximum change accuracy. Simple handling means shortest set-up times.

JET Whirling

The only tool on the market with internal cooling directly to the cutting edge. This guarantees the avoidance of chip accumulation and maximum tool life and surface qualities, with very high exchange accuracies.

HORN Turbowhirling®

Optimized cutting process by cutting division. Higher cutting data and the avoidance of chip accumulation, the downtime increases significantly.

High-Speed-Whirling

The new technology for shorter processing times offers high productivity by parallel turning and whirling. The high-speed whirling takes place with our machine and process technology partner.

System System	Einsatz Use	Vorteil Benefit	Schneid- platten Inserts
Monoblock Systeme Monobloc Systems	Universell, eingängige und mehrgängige Gewinde Universal, single- and multi-start threads	Einfache Handhabung, hohe Rundlaufgenauigkeit und Stabilität Easy to handle, high concentricity and stability	S271 S302 S301
Modulare Systeme Modular Systems	Universell, eingängige und mehrgängige Gewinde Universal, single- and multi-start threads	Einfache Handhabung, niedrige Wechselzeiten, hohe Rundlaufgenauigkeit Easy to handle, low change times, high concentricity	S271
JET-Wirbeln JET Whirling	Universell, Serienfertigung ein- und mehrgängiger Gewinde Universal, serial production single and multi-start threads	Deutlich höhere Schnittdaten durch optimierte Kühlung, hohe Standzeiten und höchste Oberflächengüten, kein Spänestau, Zeitersparnis Significantly higher cutting data through optimized cooling, long tool life and highest surface qualities, no chip accumulation, time saving	S271 S302
HORN Turbowirbeln® HORN Turbowhirling®	Hohe Spantiefen möglich, Serienfertigung ein- und mehrgängiger Gewinde High cutting depths possible, serial production single- and multi-start threads	Schnittaufteilung - dadurch höhere Schnittdaten und Standzeiten, kein Spänestau Divided cut thus higher cutting data and tool life, no chip accumulation	S271
High-Speed- Wirbeln High-Speed-Whirling	Serienfertigung ein- und mehrgängiger Gewinde Serial production of single- and multi-start thread	Hohe Produktivität durch parallele Dreh- und Wirbelbearbeitung, hohe Standzeiten und Oberflächengüten High productivity through parallel turning and whirling, long tool life and surface qualities	je nach Anforderung depending on requirements



Wirbelkopf
Whirling Head
LM271/LM302/M271/
M302

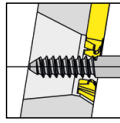

Seite/Page
618-621



www.horn-group.com/de/produkte/horn-tool-select

HORN Tool Select (HTS)

Gewindewirbeln

Finden Sie die richtigen Wirbelwerkzeuge für Ihre Maschine und Ihren Wirbelapparat.

System:

Maschine:

Wirbeleinheit:

HORN Tool Select (HTS)

HORN Thread whirling tool systems

Select the machine manufacturer and then select the model of your whirling unit to look up the appropriate HORN part numbers for the adapter and milling cutter.

System:

Maschine:

Whirling unit:

271 / 302

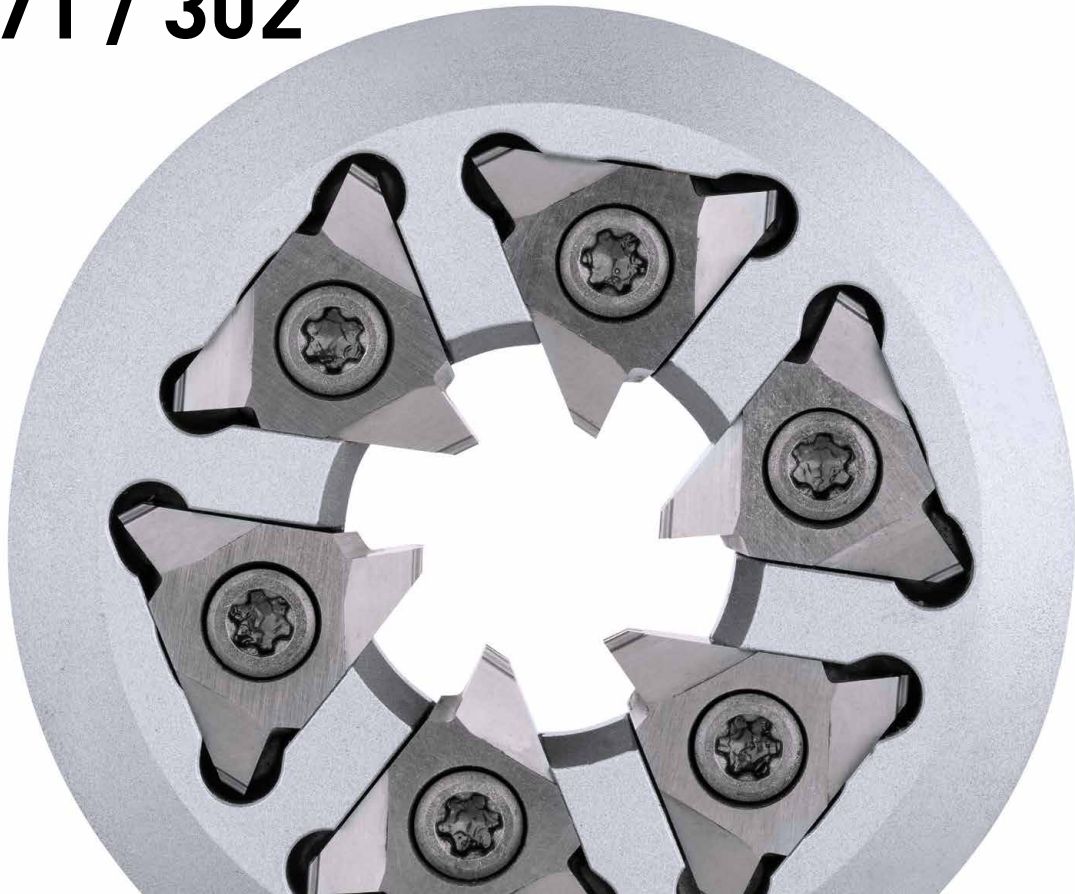

R

Monoblock System

Monobloc System

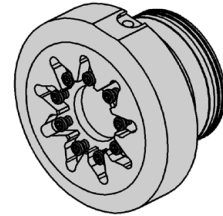
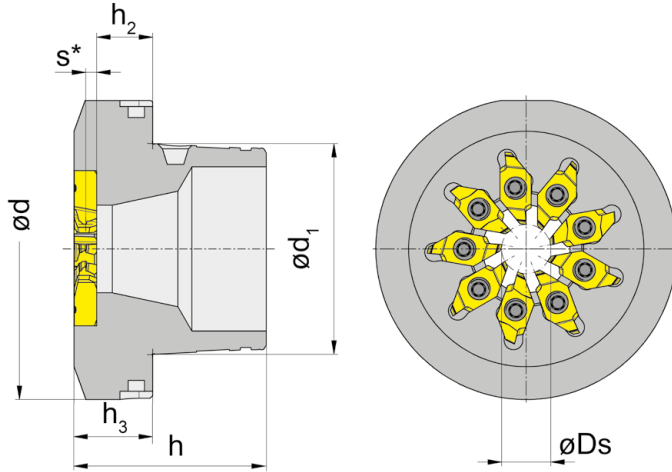
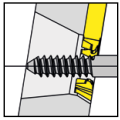

R

Bestellnummer Part number	Ds	d	d ₁	h	h ₃	h ₂	Z	Größe Size
LM271.06.WF01.14.4.9	6	55	38,5	30,15	9,4	5,25	9	04
LM271.09.WF01.14.4.9	9	55	38,5	30,15	9,4	5,25	9	04
LM271.12.WF01.14.4.9	12	55	38,5	30,15	9,4	5,25	9	04
LM271.06.WF01.15.4.9	6	55	38,5	35,15	14,4	10,25	9	04
LM271.09.WF01.15.4.9	9	55	38,5	35,15	14,4	10,25	9	04
LM271.12.WF01.15.4.9	12	55	38,5	35,15	14,4	10,25	9	04
LM271.06.WF01.18.4.9	6	55	38,5	39,15	18,4	14,25	9	04
LM271.09.WF01.18.4.9	9	55	38,5	39,15	18,4	14,25	9	04
LM271.12.WF01.18.4.9	12	55	38,5	39,15	18,4	14,25	9	04

*s ist abhängig von der Schneidplatte
*s depends on the insert

Einsatz für Wirbelapparat W&F
for W&F unit

Der Drehmomentschlüssel WFB.020.T15.PLUS zur Montage und der Exzentrerschlüssel AG.MHS.WFW.001 zur Demontage des Wirbelkopfes sind nicht im Lieferumfang enthalten. Bitte separat bestellen.
The torque wrench WFB.020.T15.PLUS for mounting and the eccentric wrench AG.MHS.WFW.001 for dismounting the whirling head are not included. Please order separately.

Ersatzteile
Spare Parts

Wirbelkopf Whirling Head	Spannschraube Clamping Screw	TORX PLUS®-Schlüssel TORX PLUS® Wrench
LM271...	030.2609.T8P	T8PL

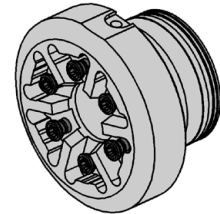
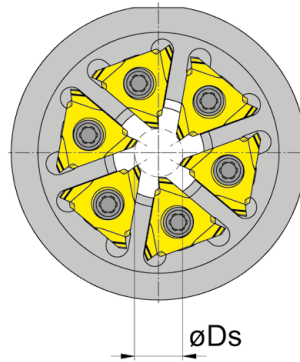
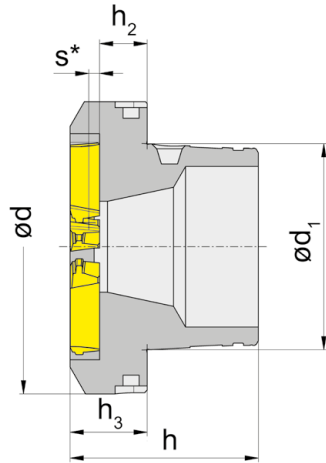
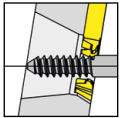

Bestellnummer Part number	Ds	d	d ₁	h	h ₂	h ₃	Z	Größe Size
LM302.06.WF01.10.5.6	6	55	38,5	31,5	5,25	10,75	6	05
LM302.06.WF01.15.5.6	6	55	38,5	35,15	8,9	14,4	6	05
LM302.06.WF01.18.5.6	6	55	38,5	39,15	12,9	18,4	6	05
LM302.09.WF01.10.5.6	9	55	38,5	31,5	5,25	10,75	6	05
LM302.09.WF01.15.5.6	9	55	38,5	35,15	8,9	14,4	6	05
LM302.09.WF01.18.5.6	9	55	38,5	39,15	12,9	18,4	6	05
LM302.12.WF01.10.5.6	12	55	38,5	31,5	5,25	10,75	6	05
LM302.12.WF01.15.5.6	12	55	38,5	35,15	8,9	14,4	6	05
LM302.12.WF01.18.5.6	12	55	38,5	39,15	12,9	18,4	6	05

*s ist abhängig von der Schneidplatte
*s depends on the insert

Einsatz für Wirbelapparat W&F
for W&F unit

Der Drehmomentschlüssel WFB.020.T15.PLUS zur Montage und der Exzentrerschlüssel AG.MHS.WFW.001 zur Demontage des Wirbelkopfes sind nicht im Lieferumfang enthalten. Bitte separat bestellen.
The torque wrench WFB.020.T15.PLUS for mounting and the eccentric wrench AG.MHS.WFW.001 for dismounting the whirling head are not included. Please order separately.

Ersatzteile

Spare Parts

Wirbelkopf Whirling Head	Spannschraube Clamping Screw	TORX PLUS®-Schlüssel TORX PLUS® Wrench
LM302...	030.0412.T15P	T15PQ



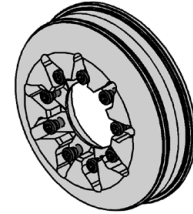
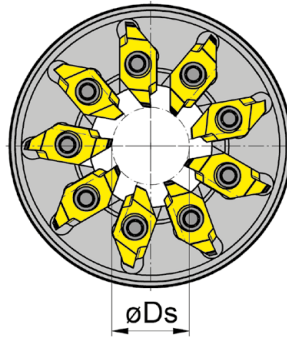
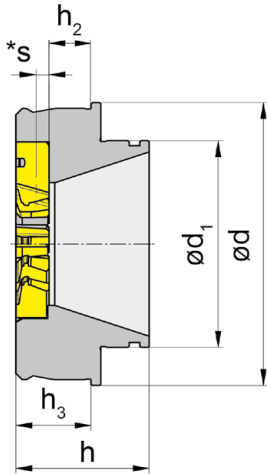
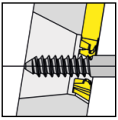

R

Bestellnummer Part number	Ds	h	h ₂	h ₃	d	Z	d ₁	Wirbelapparat Whirling unit
M271.W012.32.09	12	20,65	8,5	13,15	43,8	9	32	WTO TN762004
M271.W012.54.09	12	15,15	10,5	13,65	54	9	43,8	WTO TN762006
M271.W022.54.09	22	15,15	10,5	13,65	54	9	43,8	WTO TN762006

*s ist abhängig von der Schneidplatte
*s depends on the insert

Einsatz für Wirbelapparat WTO
for whirling unit WTO

Ersatzteile
Spare Parts

Wirbelkopf Whirling Head	Spannschraube Clamping Screw	TORX PLUS®-Schlüssel TORX PLUS® Wrench
M271...	030.2609.T8P	T8PL

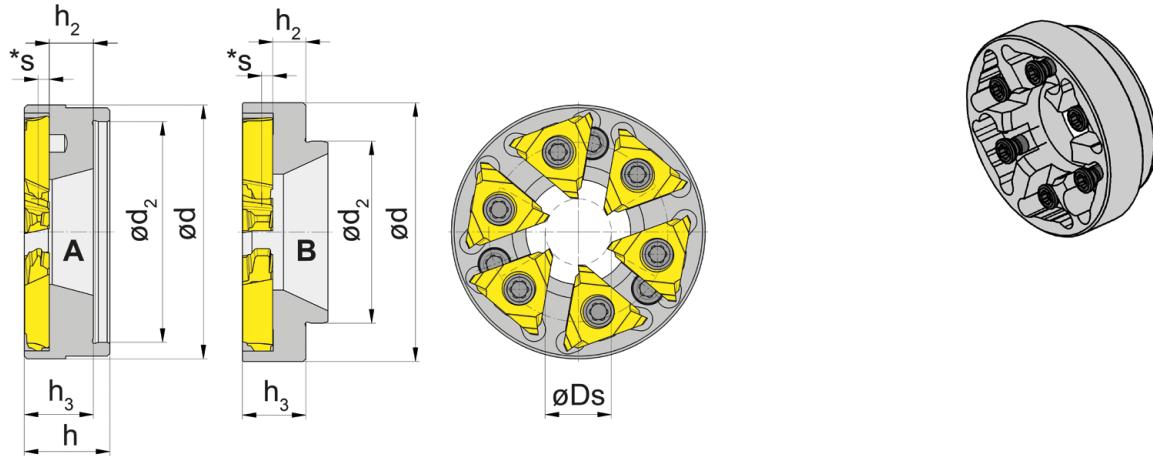
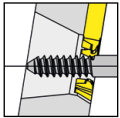

Bestellnummer Part number	Ds	h	h ₂	h ₃	d	Z	d ₂	Form
M302.A012.40.06	12	17,5	4,2	10,5	47	6	40	A
M302.C012.33.06	12	15,5	6	11,5	46,9	6	33	A
M302.C012.35.06	12	20	13	10,5	46	6	45	A
M302.C012.40.06	12	17	9	10,5	46	6	40	B
M302.C112.37.06	12	15	8	7	46	6	45	B
M302.C112.40.06	12	15,5	8	7,5	46	6	45	B
M302.T010.37.06	10	16,5	2,625	9,5	73,55	6	36,99	A
M302.W012.32.06	12	21,5	7	12,5	43,8	6	32	A
M302.W012.54.06	12	14	8,5	14	54	6	43,8	A

*s ist abhängig von der Schneidplatte
*s depends on the insert

Ersatzteile

Spare Parts

Wirbelkopf Whirling Head	Spannschraube Wirbelkopf Clamping Screw Whirling Head	Spannschraube Schneidplatte Clamping Screw Inserts	TORX PLUS®-Schlüssel TORX PLUS® Wrench
M302.A012.40.06	030.400P.0655	030.0412 T15P	T15PQ
M302.C012.33.06	-	030.400P.0761	T15PQ
M302.C012.35.06	030.400P.0655	030.0412 T15P	T15PQ
M302.C012.40.06	030.400P.0655	030.0412 T15P	T15PQ
M302.C112.37.06	3.14T9P	030.0408.T15P	T9PL/T15PQ
M302.C112.40.06	030.400P.0708	030.0408.T15P	T15PQ
M302.T010.37.06	030.400P.0655	030.0412 T15P	T15PQ
M302.T025.54.06	-	030.0408.T15P	T15PQ
M302.W012.32.06	-	030.0411 T15P	T15PQ
M302.W012.54.06	-	030.400P.0761	T15PQ

Grundaufnahme
Basic Holder
LA002

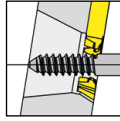

Seite/Page
624

Ringkassette
Ring cassette
LM271

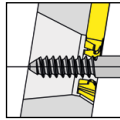

Seite/Page
625

Wirbelkopf
Whirling Head
M302

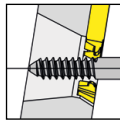

Seite/Page
626



www.horn-group.com/de/produkte/horn-tool-select

HORN Tool Select (HTS)

Gewindewirbeln

Finden Sie die richtigen Wirbelwerkzeuge für Ihre Maschine und Ihren Wirbelapparat.

System:

Maschine:

Wirbeleinheit:

HORN Tool Select (HTS)

HORN Thread whirling tool systems

Select the machine manufacturer and then select the model of your whirling unit to look up the appropriate HORN part numbers for the adapter and milling cutter.

System:

Maschine:

Whirling unit:

271 / 302



**Modulares
Gewindewirbeln**

**Modular thread
whirling system**

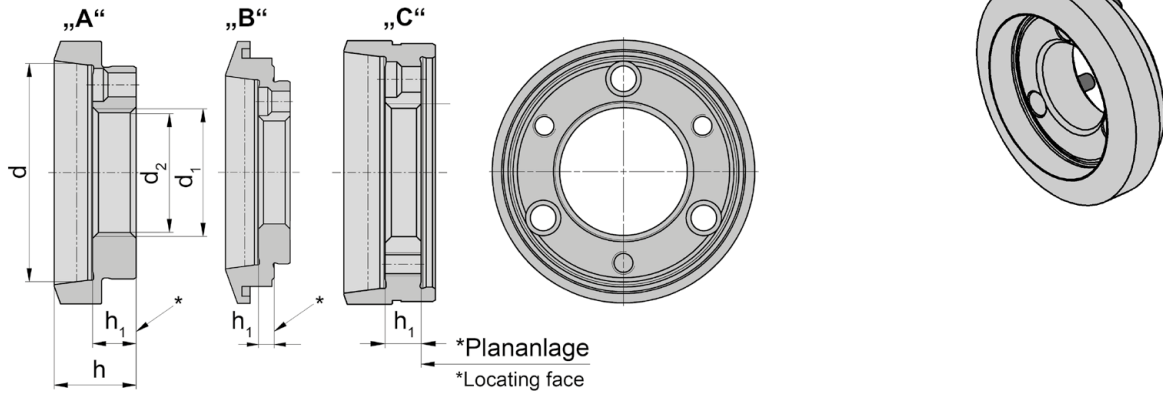
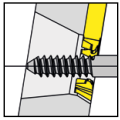

R

Bestellnummer Part number	d	d ₂	d ₁	h	h ₁	Ausführung Type
LA002.A040.4124.08	41	40	M24x1,5LH	15,4	8,2	A
LA002.A040.4124.13	41	40	M24x1,5LH	20,4	13,2	A
LA002.B033.4124.06	41	33	M24x1,5LH	16	6,3	C
LA002.B033.4124.11	41	33	M24x1,5LH	21	11,3	C
LA002.DP40.4124.03	41	40	M24x1,5LH	17,15	9,95	B
LA002.DP40.4124.08	41	40	M24x1,5LH	22,15	14,95	B
LA002.G042.4124.06	41	42,5	M24x1,5LH	13,15	5,95	B
LA002.G042.4124.11	41	42,5	M24x1,5LH	18,15	10,95	B
LA002.J037.4124.06	41	37	M24x1,5LH	16,5	6,3	C
LA002.J037.4124.11	41	37	M24x1,5LH	21,5	11,3	C
LA002.J040.4124.06	41	40	M24x1,5LH	16	6,3	C
LA002.J040.4124.11	41	40	M24x1,5LH	21	11,3	C
LA002.PC35.4124.10	41	35	M24x1,5LH	10,65	3,45	B
LA002.PC35.4124.15	41	35	M24x1,5LH	15,65	8,45	B
LA002.PC40.4124.06	41	40	M24x1,5LH	16,5	6,3	C
LA002.PC40.4124.11	41	40	M24x1,5LH	21,5	11,3	C

Ersatzteile

Spare Parts

Grundaufnahme Basic Holder	Spannschraube Clamping Screw	TORX PLUS®-Schlüssel TORX PLUS® Wrench
LA002.A040.../...J040...	4.14T15P	T15PQ
LA002.PC040.../...DP40...	4.12T15EP	T15PQ
LA002.J037.4124.06	3.14T9P	T9PL
LA002.J037.4124.11	4.14T15P	T9PL
LA002.PC35.4124.10	4.16T15P	T15PQ

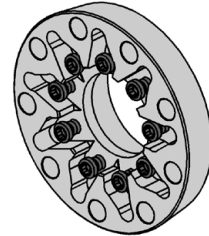
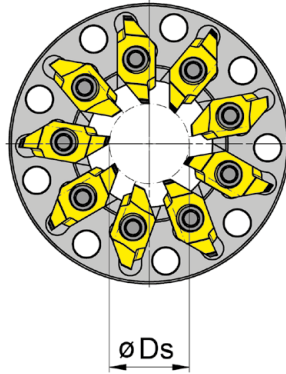
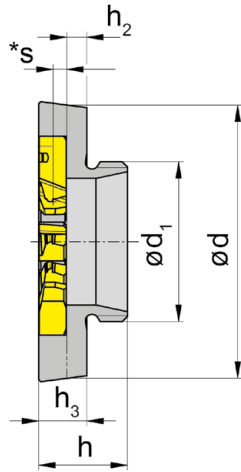
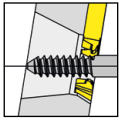

Bestellnummer Part number	Ds	d	d ₁	h	h ₃	h ₂	Z	Größe Size
LM271.06.4124.07.4.6	6	41	M24x1,5LH	13,3	7,2	3	6	04
LM271.06.4124.07.4.9	6	41	M24x1,5LH	13,3	7,2	3	9	04
LM271.09.4124.07.4.6	9	41	M24x1,5LH	13,3	7,2	3	6	04
LM271.09.4124.07.4.9	9	41	M24x1,5LH	13,3	7,2	3	9	04
LM271.12.4124.07.4.6	12	41	M24x1,5LH	13,3	7,2	3	6	04
LM271.12.4124.07.4.9	12	41	M24x1,5LH	13,3	7,2	3	6	04
LM271.12.4124.08.5.9	12	41	M24x1,5LH	14,3	8,2	3	9	05

*s ist abhängig von der Schneidplatte
*s depends on the insert

Der Schlüssel **020.3504.5410** gehört nicht zum Lieferumfang der Ringkassette. Bitte separat bestellen!
Wrench 020.3504.5410 is not combined with the ring cassette - separate order required!

LM271...6 = konventionelles Wirbeln
LM271...9 = HORN Turbowirbeln®
LM271...6 = conventional whirling
LM271...9 = HORN Turbowhirling®

Ersatzteile

Spare Parts

Ringkassette Ring cassette	Spannschraube Clamping Screw	TORX PLUS®-Schlüssel TORX PLUS® Wrench
LM271...	030.260P.1013	T8PL

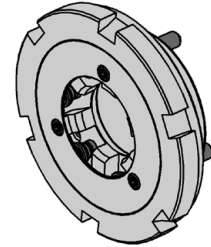
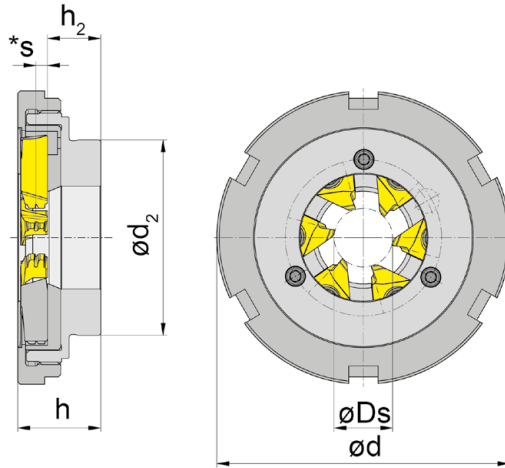
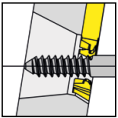

R

Bestellnummer Part number	Ds	h	h ₂	d	Z	d ₂
M302.AM12.40.06	12	20,7	14,4	52	6	40
M302.AM12.T.40.06	12	17	10,7	60	6	40
M302.DM11.0.40.06	11	20,5	8,5	60	6	40

*s ist abhängig von der Schneidplatte
*s depends on the insert

Ersatzteile

Spare Parts

Wirbelkopf Whirling Head	Spannschraube Clamping Screw	Spannschraube Clamping Screw	TORX PLUS®-Schlüssel TORX PLUS® Wrench	Grundaufnahme Basic Holder	Inbus-Schlüssel Allen Wrench
M302.AM12.40.06	030.400P.0708	030.0412.T15P	T15PQ	-	-
M302.AM12.T.40.06	-	-	T8PL	002.4640.1634	-
M302.DM11.0.40.06	-	-	T15PQ	002.4540.1620	SW2,0 DIN911

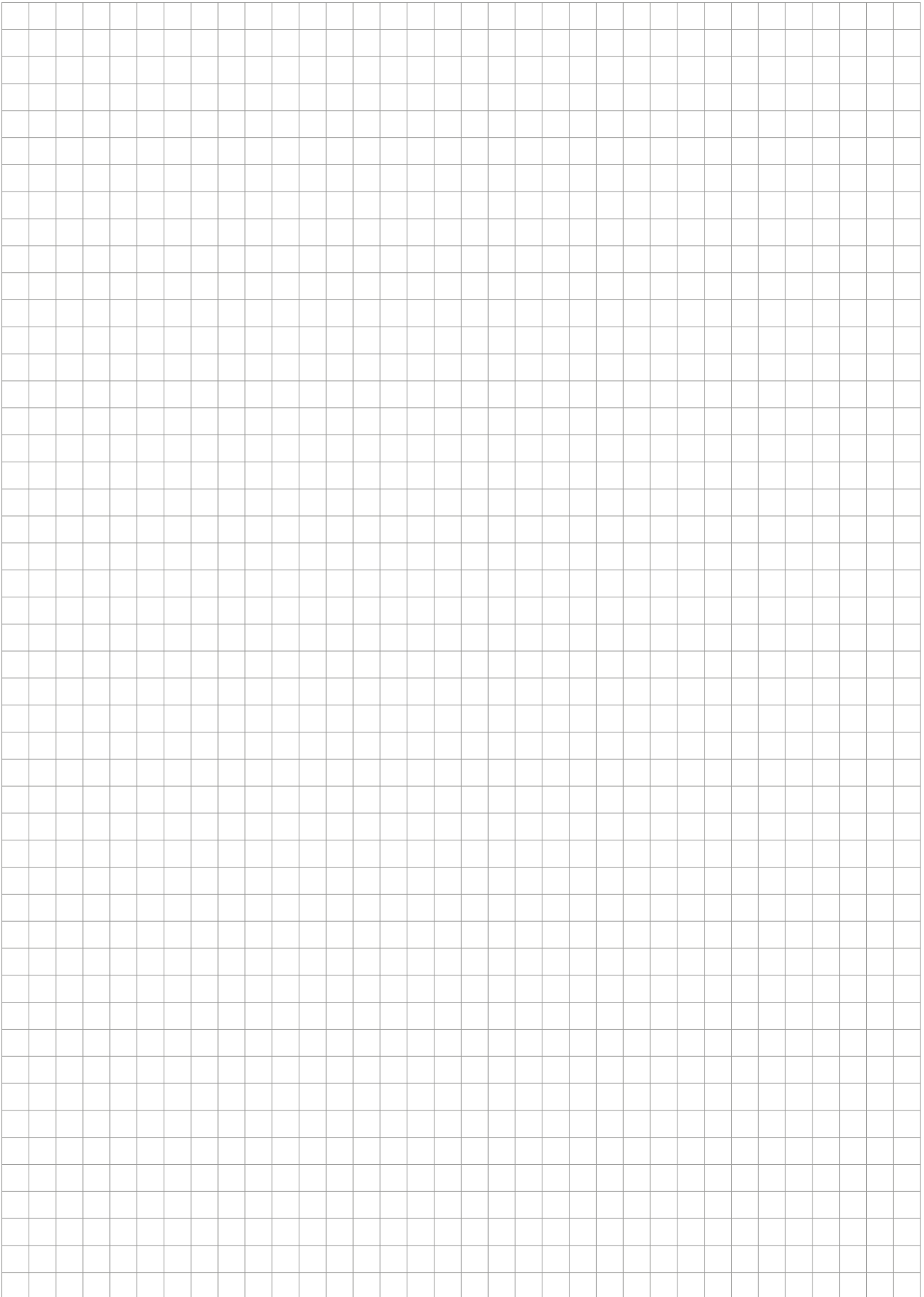

Wirbelkopf
Whirling Head
LM271/LM302

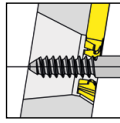

Seite/Page
630-632

Übersicht
Overview

Seite/Page
633



www.horn-group.com/de/produkte/horn-tool-select

HORN Tool Select (HTS)

Gewindewirbeln

Finden Sie die richtigen Wirbelwerkzeuge für Ihre Maschine und Ihren Wirbelapparat.

System:

Maschine:

Wirbeleinheit:

HORN Tool Select (HTS)

HORN Thread whirling tool systems

Select the machine manufacturer and then select the model of your whirling unit to look up the appropriate HORN part numbers for the adapter and milling cutter.

System:

Maschine:

Whirling unit:



JET-Wirbeln

- Einziges Wirbelwerkzeug mit innerer Kühlmittelzufuhr
- Hohe Standzeit und Oberflächengüten
- Hohe Wechselgenauigkeit beim Wechsel des Wirbelkopfes

JET Whirling

- The only whirling tool to feature an internal coolant supply
- Long tool life and excellent surface quality thanks to targeted cooling of the cutting zone
- Accurate indexability when changing the whirling head owing to the precise interface

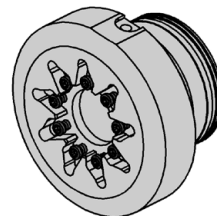
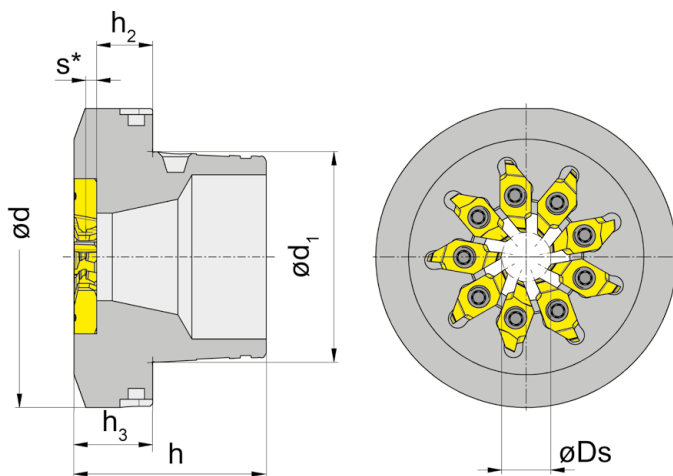
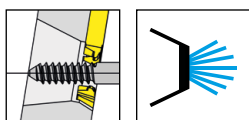

R

Bestellnummer Part number	Ds	d	d ₁	h	h ₂	h ₃	Z	Größe Size
LM271.09.WF01.14.4.9.IK	9	55	38,5	30,15	5,25	9,4	9	04
LM271.12.WF01.14.4.9.IK	12	55	38,5	30,15	5,25	9,4	9	04
LM271.06.WF01.15.4.9.IK	6	55	38,5	35,15	10,25	14,4	9	04
LM271.09.WF01.15.4.9.IK	9	55	38,5	35,15	10,25	14,4	9	04
LM271.12.WF01.15.4.9.IK	12	55	38,5	35,15	10,25	14,4	9	04
LM271.06.WF01.18.4.9.IK	6	55	38,5	39,15	14,25	18,4	9	04
LM271.09.WF01.18.4.9.IK	9	55	38,5	39,15	14,25	18,4	9	04
LM271.12.WF01.18.4.9.IK	12	55	38,5	39,15	14,25	18,4	9	04

*s ist abhängig von der Schneidplatte

*s depends on the insert

Einsatz nur für W&F JET-Wirbelapparat

Use only for W&F JET whirling unit

Der Drehmomentschlüssel WFB.020.T15.PLUS zur Montage und der Exzentrerschlüssel AG.MHS.WFW.001 zur Demontage des Wirbelkopfes sind nicht im Lieferumfang enthalten. Bitte separat bestellen.

The torque wrench WFB.020.T15.PLUS for mounting and the eccentric wrench AG.MHS.WFW.001 for dismounting the whirling head are not included. Please order separately.

Ersatzteile

Spare Parts

Wirbelkopf Whirling Head	Spannschraube Clamping Screw	TORX PLUS®-Schlüssel TORX PLUS® Wrench
LM271...	030.2609.T8P	T8PL

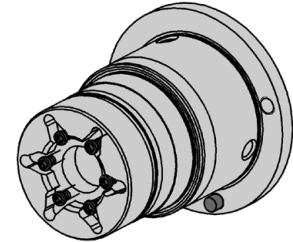
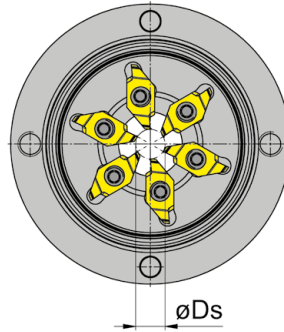
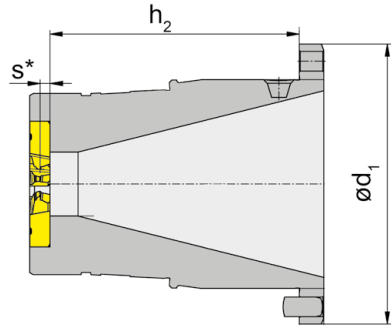
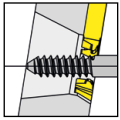

Bestellnummer Part number	D_s	h_2	d_1	Z	Größe Size
LM271.06.WF02.55.4.6	6	50,85	57	6	04

*s ist abhängig von der Schneidplatte
*s depends on the insert

Einsatz für Wirbelapparat W&F
for W&F unit

Der Drehmomentschlüssel WFB.020.T15.PLUS zur Montage und der Exzentrerschlüssel AG.MHS.WFW.001 zur Demontage des Wirbelkopfes sind nicht im Lieferumfang enthalten. Bitte separat bestellen.

The torque wrench WFB.020.T15.PLUS for mounting and the eccentric wrench AG.MHS.WFW.001 for dismounting the whirling head are not included. Please order separately.

Ersatzteile
Spare Parts

Wirbelkopf Whirling Head	Spannschraube Clamping Screw	TORX PLUS®-Schlüssel TORX PLUS® Wrench
LM271.06.WF02.55.4.6	030.2609.T8P	T8PL



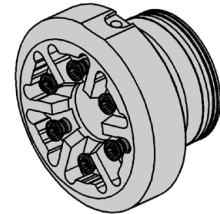
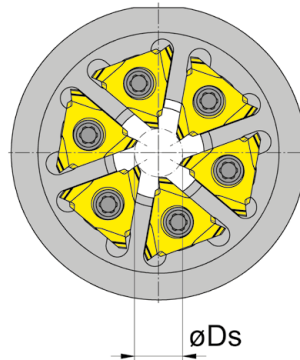
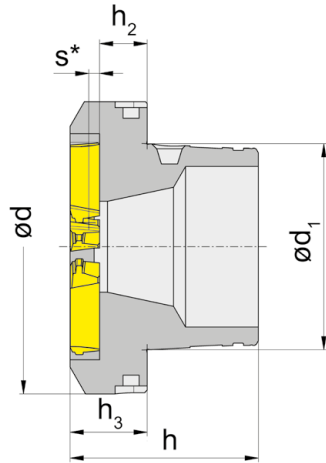
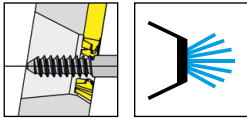

R

Bestellnummer Part number	Ds	d	d ₁	h	h ₂	h ₃	Z	Größe Size
LM302.09.WF01.10.5.6.IK	9	55	38,5	31,5	5,25	10,75	6	05
LM302.12.WF01.10.5.6.IK	12	55	38,5	31,5	5,25	10,75	6	05
LM302.06.WF01.15.5.6.IK	6	55	38,5	35,15	8,9	14,4	6	05
LM302.09.WF01.15.5.6.IK	9	55	38,5	35,15	8,9	14,4	6	05
LM302.12.WF01.15.5.6.IK	12	55	38,5	35,15	8,9	14,4	6	05
LM302.06.WF01.18.5.6.IK	6	55	38,5	39,15	12,9	18,4	6	05
LM302.09.WF01.18.5.6.IK	9	55	38,5	39,15	12,9	18,4	6	05
LM302.12.WF01.18.5.6.IK	12	55	38,5	39,15	12,9	18,4	6	05

*s ist abhängig von der Schneidplatte
*s depends on the insert

Einsatz nur für W&F JET-Wirbelapparat
Use only for W&F JET whirling unit

Der Drehmomentschlüssel WFB.020.T15.PLUS zur Montage und der Exzentrerschlüssel AG.MHS.WFW.001 zur Demontage des Wirbelkopfes sind nicht im Lieferumfang enthalten. Bitte separat bestellen.
The torque wrench WFB.020.T15.PLUS for mounting and the eccentric wrench AG.MHS.WFW.001 for dismounting the whirling head are not included. Please order separately.

Ersatzteile

Spare Parts

Wirbelkopf Whirling Head	Spannschraube Clamping Screw	TORX PLUS®-Schlüssel TORX PLUS® Wrench
LM302...	030.0412.T15P	T15PQ

Durch die hohe Rundlaufgenauigkeit der Schnittstelle und der gleichmäßigen Abnutzung der Schneidplatten, kann eine signifikante Standzeiterhöhung erreicht werden.

Wechseln des Einsatzes:	< 1 min
Rundlaufgenauigkeit:	< 3 μ
Wechselwiederholgenauigkeit:	< 2 μ
max. Drehzahl:	8.000 U/min
Innenkühlung:	80 bar
Verstellbereich:	+/- 20°

Verfügbar für alle gängigen Langdrehmaschinen.

Due to the high concentricity of the interface and the even wear of the inserts, a significant increase in tool life can be achieved.

Changing the insert:	< 1 min
Concentricity:	< 3 μ
Repeatability of changes:	< 2 μ
Rotation speed max:	8.000 U/min
Internal coolant:	80 bar
Adjustment range:	+/- 20°

Available for all common Swiss type machines.



Durch das Zusammenspiel von Kegel-Plananlage mit zylindrischem Bund, erreichen wir höchste Genauigkeit in der Schnittstelle und ebenso ein bedienerfreundliches Wechseln der Einsätze mit lediglich drei Schrauben.

Due to the interplay of conical face plant with cylindrical collar, we achieve the highest accuracy in the interface as well as user-friendly replacement of the inserts with only three screws.

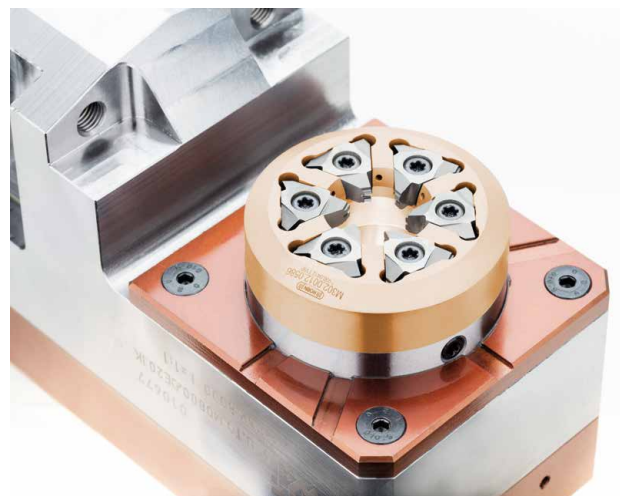

R

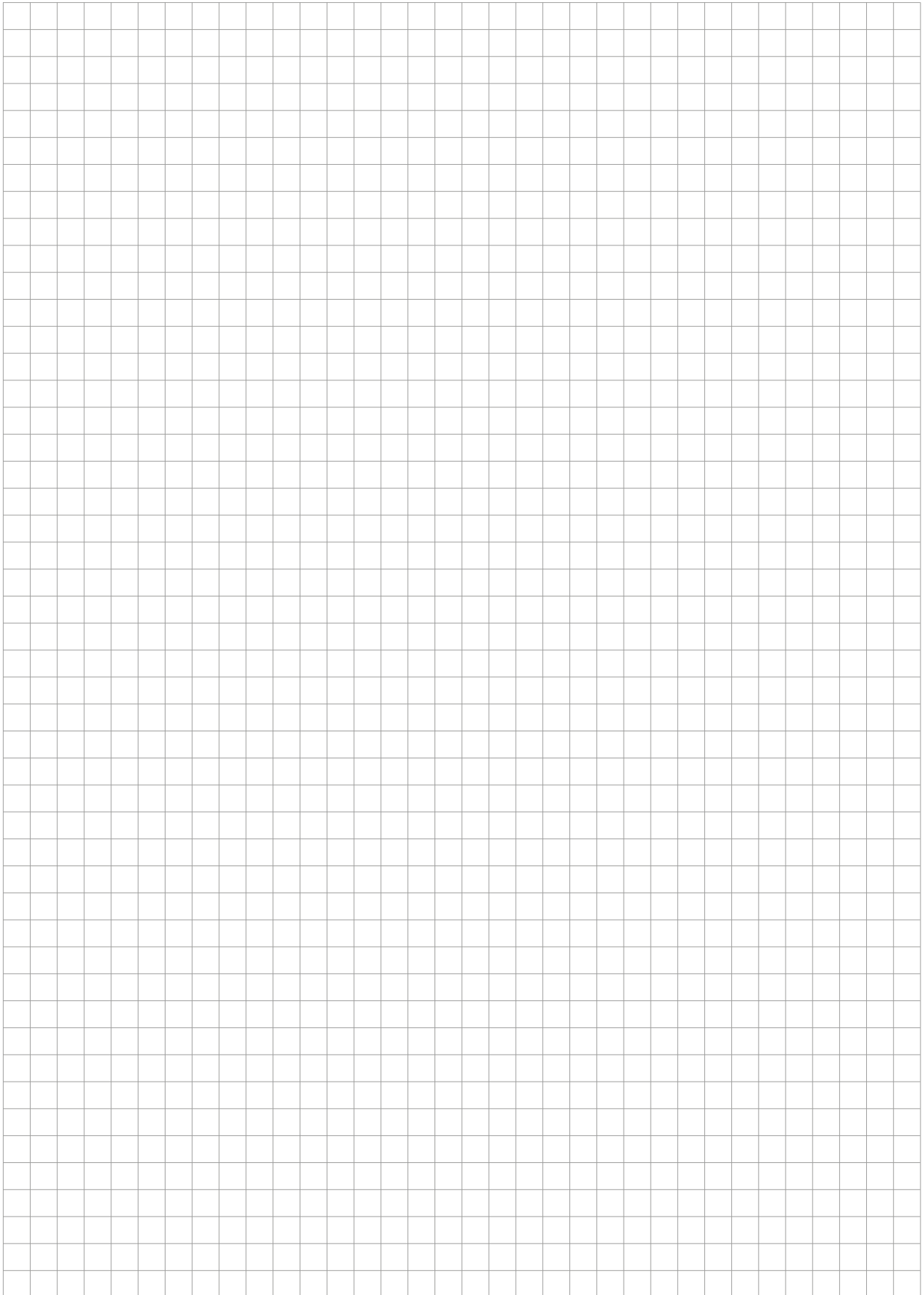



R

**HORN
Turbowirbeln®**

**Doppelt so schnell bei
erhöhter Standzeit!**

Vor- und Fertigwirbeln
in einem Prozess

**HORN
Turbo whirling®**

**Twice as fast with
higher tool life**

Pre- and finish whirling
in a single process

Der neu entwickelte Prozess des HORN Turbowirbelns optimiert die Zerspanung beim Gewindewirbeln und erhöht die Wirtschaftlichkeit. Speziell zur Bearbeitung von Gewinden mit größerem Aufmaß entwickelte HORN Schneidwerkzeuge für das Wirbeln mit neuer Schnittaufteilung. Einzelne Schneiden arbeiten dazu als Vorschneider und zerspanen das Werkstück bis zum definierten Außendurchmesser. Bei neunschneidigen Werkzeugen wird über Schnittaufteilung die Zerspanungsarbeit so aufgeteilt, dass jede Schneide gleichmäßig belastet wird und dadurch die einzelnen Schneiden signifikant höhere Standzeiten erzielen. Die Schlichtschneiden erzeugen im optimierten Arbeitsbereich die fertigen Gewindeflanken. Unabhängig vom Werkstückaußendurchmesser entsteht durch die Kombination unterschiedlicher Schneidenprofile so ein optimales Gewinde mit reproduzierbaren Standmengen.

Das HORN Turbowirbeln ist anwendbar bei ein- und mehrgängigen Gewinden und Profilen. Die präzisionsgeschliffenen zweischneidigen Wendeschneidplatten vom Typ S271 werden dabei individuell auf das jeweilige Gewindeprofil und den zu zerspanenden Werkstoff abgestimmt. Gespannt werden die Wendeschneidplatten in formschlüssigen, extrem stabilen Plattensitzen, entweder in den neuen modularen Wirbelköpfen mit optimiertem Handling beim Plattenwechsel, oder konventionell in den Monoblock-Werkzeugen.

The newly developed HORN Turbo Whirling process optimises machining during thread whirling and increases efficiency. HORN has developed cutting tools for whirling with a new cutting division specially for machining threads with a larger allowance. To this end, individual cutting edges work as pre-cutters and machine the workpiece to the defined external diameter. In the case of nine-cutter tools, the cutting division allows the machining work to be divided so that each cutting edge is subject to equal load, meaning that individual cutting edges can achieve significantly higher service lives. The finishing cutting edges produce the finished thread flanks within the optimised working range. Regardless of the external workpiece diameter, combining a range of cutting edge profiles creates an optimum thread with reproducible tool life.

HORN Turbo Whirling can be applied to single-start and multi-start threads and profiles. What's more, during this process, the S271 precision-ground double-edged indexable inserts are tailored to the respective thread profile and the material to be machined. The indexable inserts are clamped in positive-fit, extremely stable insert seats either in the new modular whirling heads with optimised handling during insert replacement or conventionally in the Mono block tools.



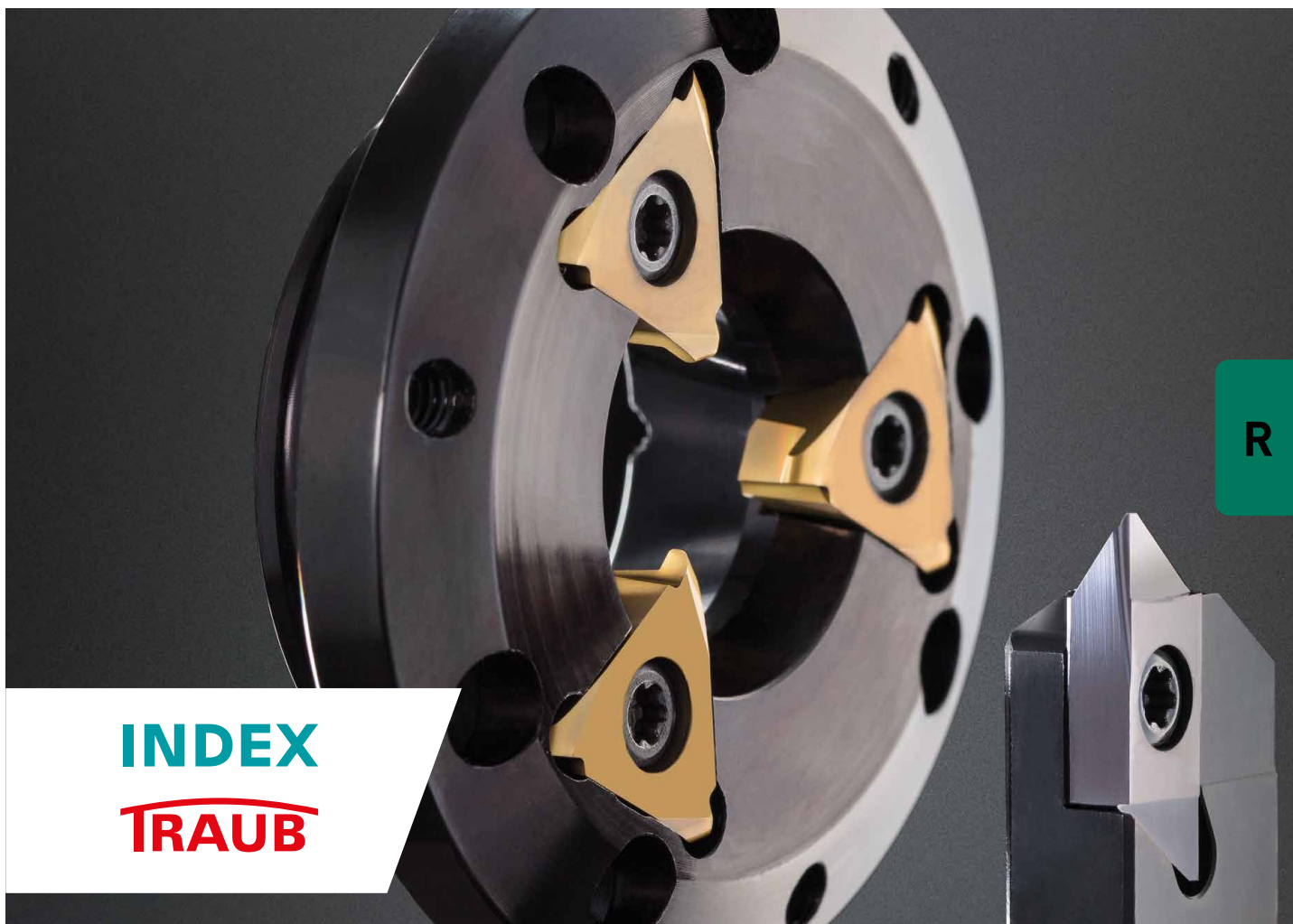

INDEX
TRAUB

High-Speed-Wirbeln

Neue Technologie für kürzere
Bearbeitungszeiten

High-Speed-Whirlinging

New technology for shorter
machining times

- Hohe Produktivität durch parallele Dreh- und Wirbelbearbeitung
- Hohe Standzeiten und Oberflächengüten
- Maschinen- und Prozess-technologiepartner Index / Traub
- High productivity through turning and whirling operations performed simultaneously
- Long tool life and excellent surface quality as a result of pre-turning the thread diameter
- Machine and process technology partners Index / Traub

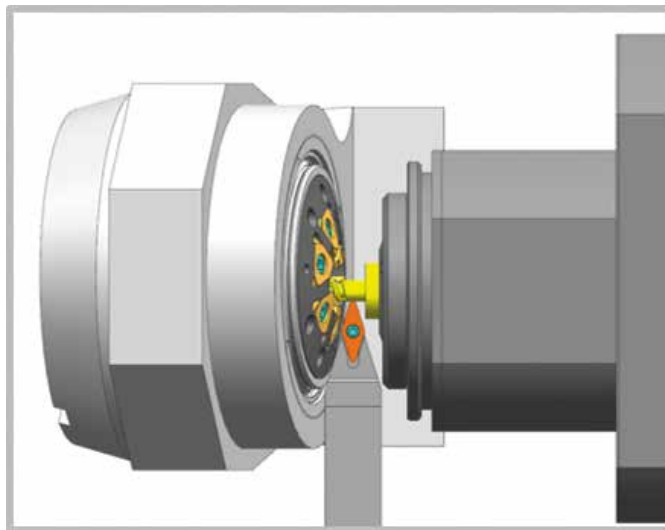

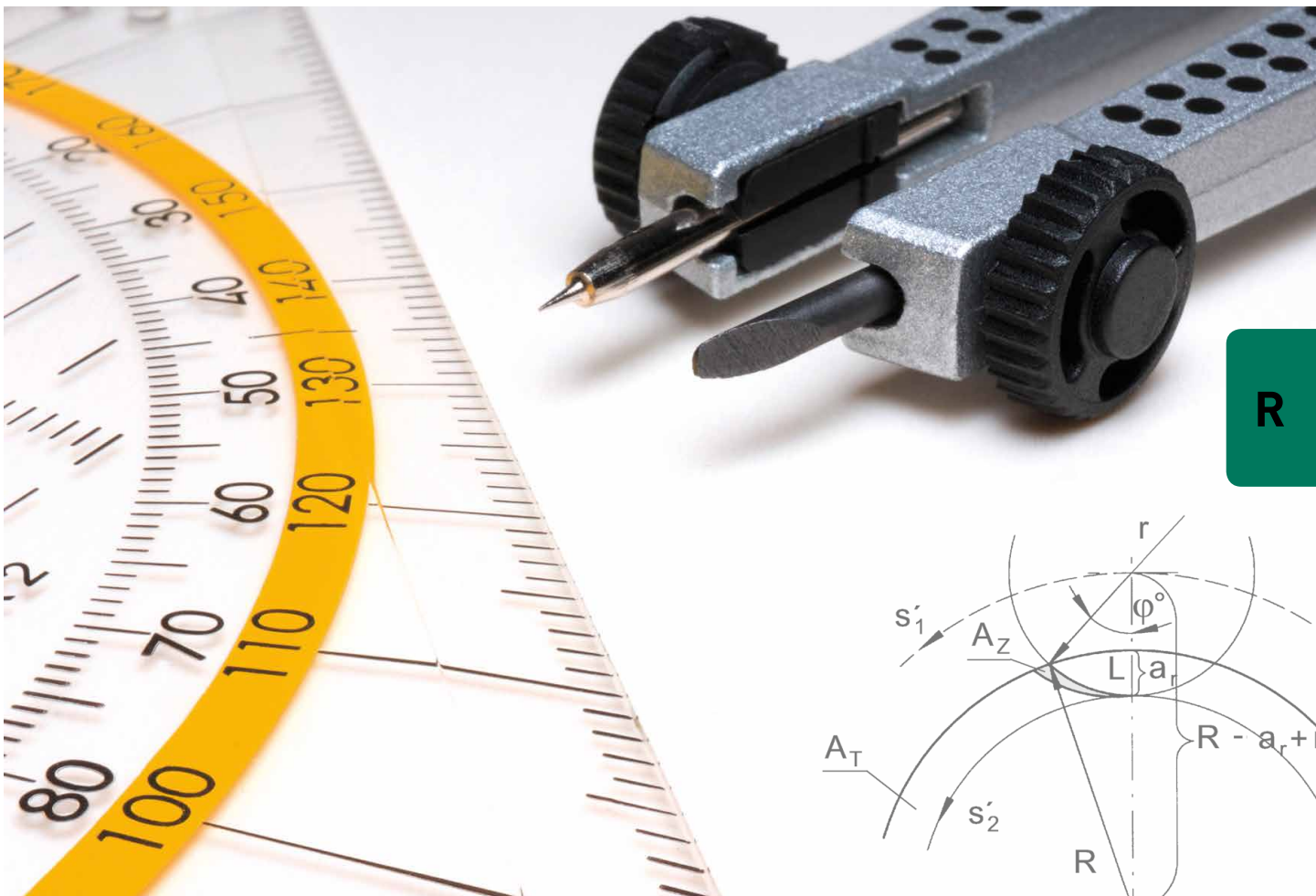

Inhalt/Summary

Seite/Page

Technische Informationen

640-643

Technical Informations

Technische Anfrage

644

Technical Enquiry

Eine Übersicht angetriebener Gewindewirbelwerkzeuge finden Sie hier:

An overview of driven thread whirling tools you can find here:

www.horn-group.com/fileadmin/main-website/Catalogues/Katalog-Horn-WF-Gewindewirbeln.pdf

1. Feinstgeschliffene Spanflächen zur Vermeidung von Aufbauschneiden
2. Schartenfreie Schneidkante für beste Oberflächengüten am Werkstück
3. Innenliegende Kleinstradien von 0,02 mm für „scharfe“ Gewinde
4. Auf den Werkstoff abgestimmte Schneidengeometrie für beste Performance
5. Ganzzahlige Einstellwinkel am Wirbelapparat vereinfachen das Einstellen des Schwenkwinkels am Wirbelapparat

1. Fine ground top rake to avoid built up edge
2. Notch-free cutting edge for best surface finish on the workpiece
3. Concave small radii of 0.02 mm for „sharp“ threads
4. Special cutting geometry adapted to the material for best performance
5. Integer adjustment angles simplify the adjustment of the swivel angle on the thread whirling unit

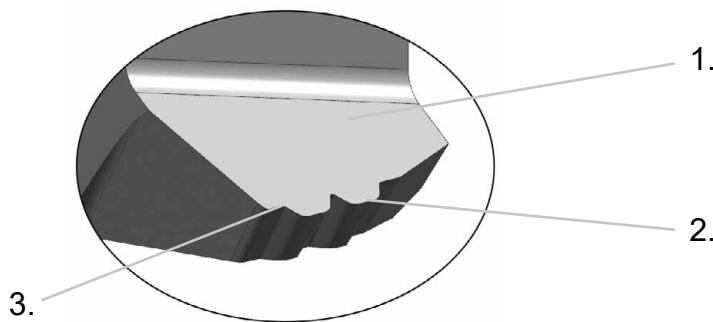

Typ / type S271 w < 6,1 mm	Typ / type S302 w < 7,5 mm Typ / type S301 w < 4,5 mm

Um beste Performance zu gewährleisten, werden die Schneidplatten individuell an die Kundenanforderung angepasst.

Die Greenline Produktionsphilosophie garantiert kürzeste Lieferzeiten.

To ensure the best performance, the inserts are individually tailored to the customer's requirements. The greenline production philosophy guarantees shortest delivery times.

Beschichtungsempfehlung / Coating Recommendation

Titan / Titanlegierungen / Titanium / Titanium alloys	SG3P
Rostfreie Stähle / Stainless steels	SG3P
Stahl, legiert und unlegiert / Steel, alloyed and unalloyed	RC25
Aluminium	DD25
Warmfeste Legierungen / Heat resistant alloys	SG3P

Schnittdaten können mit dem Schnittdatenrechner auf unserer Website unter <https://hct.phorn.de/de/Home.aspx> bestimmt werden.

Cutting data can be determined with the cutting data calculator on our website with <https://hct.phorn.de/de/Home.aspx>

Berechnung der Spitzenhöhenkorrektur der Werkzeugschneide

Calculation of the centre height correction of the cutting edge

Schwenkwinkel α / Swing angle α

Der Schwenkwinkel entspricht i.d.R. dem mittleren Steigungswinkel des Gewindes. Dieser berechnet sich wie folgt.

The swing angle usually cover the medium pitch angle of thread. According following calculation:

$$\tan \alpha = \frac{P}{\pi x d}$$

Um das Einstellen des Gewindewirbelapparates zu vereinfachen, werden Horn-Gewindewirbelplatten immer auf ganzzahligen Einstellwinkel konstruiert. Der einzustellende Schwenkwinkel ist der Wendeplattenzeichnung zu entnehmen!

To simplify the adjusting of the whirling unit, at HORN we design the insert to whole pitch angle number for setup in machine.

The swivel angle to be set can be found in the insert drawing!

z.B. / e.g.

mittlerer Steigungswinkel / medium pitch angle:	7.77°
Schwenkwinkel Wirbelkopf / swing angle whirling head:	7°
ausgelegt für Schneidkreis- \emptyset / designed for cutting- \emptyset :	6 mm

Spitzenhöhenkorrektur / Centre height correction

Oftmals liegt die Schneide nicht exakt auf der Schwenkachse (Maß Δh) des Gewindewirbelapparates. Wird dieser nun in Steigungsrichtung des Gewinde eingeschwenkt liegt die Schneide nicht mehr auf Spitzenhöhe. In solchen Fällen muss daher eine Spitzenhöhenkorrektur erfolgen. Wenn „ Δh “ = 0 ist, ist keine Korrektur nötig.

The cutting edge is often not exactly on the swivel axis (dimension Δh) of the thread whirling unit. If this is now swiveled in in the direction of the thread, the cutting edge is no longer at centre height. In such cases, a centre height correction must be made. If „ Δh “ = 0, no correction is necessary.

Nachstehend wird erläutert wie diese berechnet werden kann:

The following explains how this can be calculated:

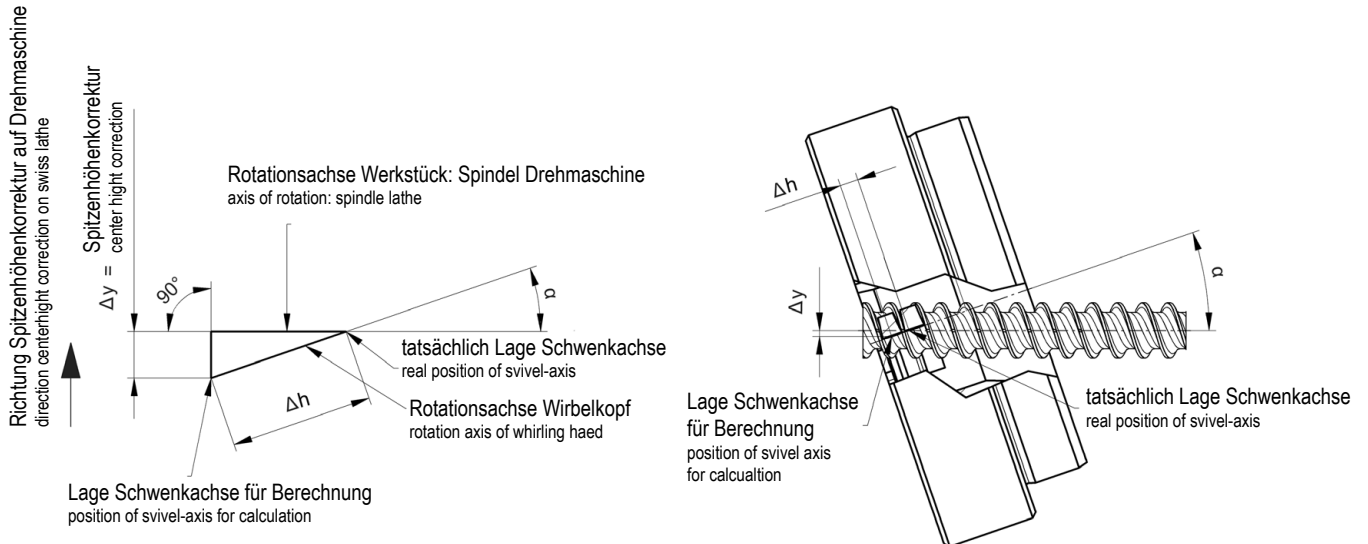

Berechnung des Korrekturwerts Δy

Calculation of the correction value Δy

$$\Delta y = \Delta h \times \sin \alpha$$

→ online <https://hct.phorn.de/>

- H** Abstand Schwenkachse Wirbelapparat zur Anlage Wirbelkopf (ist abhängig vom Gewindewirbelapparat)
Distance swivel-axis whirling unit / location face whirling head (is depending on the thread whirling unit whirling unit)
- h₂** Abstand Anlage Wirbelkopf zur Anlage Schneidplatte (diese Maß wird der Tabelle entnommen)
Distance locating face whirling head / locating face of the insert (this measure is taken from the table)
- ΔL** Abstand Schwenkmitte der Schneidplatte zur Schwenkachse des Wirbelapparats
Distance centre of form of the insert / swivel-axis of the whirling unit
- Δy** Korrekturwert Spitzenhöhe
Correction value centre height
- α** Schwenkwinkel Werkzeug
Swivel angle of the tool
- *s** Abstand Anlage Schneidplatte zum theoretischen Berechnungspunkt (diese Maß hängt von der entsprechenden Gewindewirbelplatte ab, kann der Zeichnung entnommen werden)
Distance locating face insert to the theoretical calculation point (this dimension depends on the corresponding insert which can be seen in the drawing)

Ermittlung des Δh anhand Beispiel von:

Calculation of Δh based on example on:

LM271.06.WF01.18.4.9.IK
+
MPU.LSW.101.MX815.L20

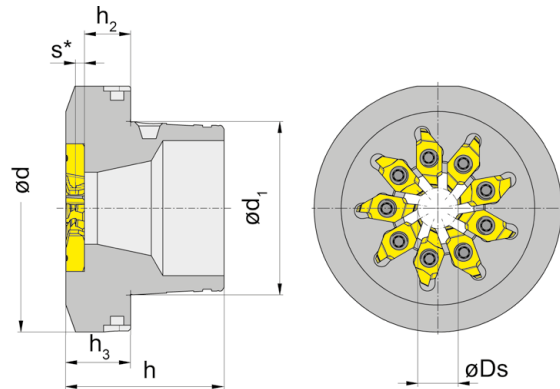

Bestellnummer Part number	Ds	d	d ₁	h	h ₂	h ₃	Z	Größe Size
LM271.06.WF01.14.4.9.IK	6	55	38,5	30,15	5,25	9,4	9	04
LM271.09.WF01.14.4.9.IK	9	55	38,5	30,15	5,25	9,4	9	04
LM271.12.WF01.14.4.9.IK	12	55	38,5	30,15	5,25	9,4	9	04
LM271.06.WF01.15.4.9.IK	6	55	38,5	35,15	10,25	14,4	9	04
LM271.09.WF01.15.4.9.IK	9	55	38,5	35,15	10,25	14,4	9	04
LM271.12.WF01.15.4.9.IK	12	55	38,5	35,15	10,25	14,4	9	04
LM271.06.WF01.18.4.9.IK	6	55	38,5	39,15	14,25	18,4	9	04
LM271.09.WF01.18.4.9.IK	9	55	38,5	39,15	14,25	18,4	9	04
LM271.12.WF01.18.4.9.IK	12	55	38,5	39,15	14,25	18,4	9	04

$$\Delta h = h_2 + s + (H)$$

$$\Delta h = 14,25 + 2 + (-7,25)$$



$$\Delta h = 9$$

Werkstoff / Material	Kundenzeichnung / Customer Drawing No.:
Schulzwerk nach ISO 6076	Teilenummer / Part No.:
ISO 6076	Skala / Scale: 1:1.25
ISO 6076	ISO 1445-10
ISO 6076	Qualität / quality:
ISO 6076	Zusammenbau
ISO 6076	Zeichnung / Drawing No.: 085.0302.1932
ISO 6076	Ers.f.:
ISO 6076	Ers.d.:

H = Abstand Anlagefläche Wirbelkopf zu Schwenkachse Wirbelheit/
distance location face whirling head / swivel axis whirling unit
Spitzenhöhenkorrektur: $\Delta h = (s+h_2-H) \times \sin(\text{Schwenkwinkel})$
centre height correction: $\Delta h = (s+h_2-H) \times \sin(\text{swivel angle})$

Bereitgestellte Zeichnungen in Papierform oder digitalem Format unterliegen nicht dem Änderungsdienst

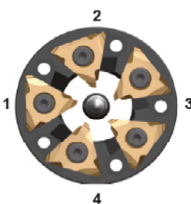

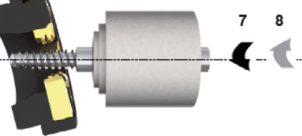
<p>Schnittposition Cutting location</p> 	<p>Drehrichtung Werkzeug Turning direction of whirling unit</p> 	<p>Drehrichtung Stange Turning direction of bar</p> 	<p>Schnittposition <i>position de la coupe</i> Cutting position</p> <p>1 / 2 / 3 / 4</p>										
			<p>Drehrichtung Werkzeug <i>direction de l'outil</i> Turning direction whirling tool</p> <p>5 / 6</p>										
			<p>Drehrichtung Stange <i>direction de la barre</i> turning direction of the bar</p> <p>7 / 8</p>										
<p>Maschinenhersteller: <i>Marque de la machine:</i> <i>Machine manufacturer:</i></p>													
<p>Maschinentyp: <i>Type de la machine:</i> <i>Type of machine:</i></p>													
<p>Angetriebenes Werkzeug <i>Typ/Bezeichnung</i> <i>Marque de l'appareil à tourbillonner</i> <i>Type of the driven tool:</i></p>													
<p>Y-Achse vorhanden <i>Axe y-disponible?</i> <i>Y-axis available?</i></p>	<table border="1" style="width:100%;"> <tr><td><i>Ja</i></td><td><i>Nein</i></td></tr> <tr><td><i>Oui</i></td><td><i>Non</i></td></tr> <tr><td><i>Yes</i></td><td><i>No</i></td></tr> </table>	<i>Ja</i>	<i>Nein</i>	<i>Oui</i>	<i>Non</i>	<i>Yes</i>	<i>No</i>	<p>Kühlung vorhanden <i>Lubrification disponible?</i> <i>Coolant available</i></p>	<table border="1" style="width:100%;"> <tr><td><i>Ja/Oui/Yes</i></td><td><i>Nein/Non/No</i></td></tr> <tr><td colspan="2"><i>Druck / pression / pressure</i></td></tr> </table>	<i>Ja/Oui/Yes</i>	<i>Nein/Non/No</i>	<i>Druck / pression / pressure</i>	
<i>Ja</i>	<i>Nein</i>												
<i>Oui</i>	<i>Non</i>												
<i>Yes</i>	<i>No</i>												
<i>Ja/Oui/Yes</i>	<i>Nein/Non/No</i>												
<i>Druck / pression / pressure</i>													
<p>Werkstoff <i>Matière:</i> <i>Material:</i> <input style="width:200px;" type="text"/></p>		<p>Ø <input style="width:50px;" type="text"/></p>											
<p>Gewindebezeichnung <i>Specification du filet:</i> <i>Thread specification:</i></p>													
<p>Vollprofil: <i>Profil complet:</i> <i>Full profile:</i></p> <table border="1" style="width:100%; text-align: center;"> <tr><td><i>Ja</i> <i>Oui</i> <i>yes</i></td><td><i>Nein</i> <i>non</i> <i>no</i></td></tr> </table>				<i>Ja</i> <i>Oui</i> <i>yes</i>	<i>Nein</i> <i>non</i> <i>no</i>								
<i>Ja</i> <i>Oui</i> <i>yes</i>	<i>Nein</i> <i>non</i> <i>no</i>												
<p>Konventionelles Wirbeln <i>HORN Tourbillonnage</i> <i>HORN Whirling</i></p> <table border="1" style="width:100%; text-align: center;"> <tr><td><i>Ja</i> <i>Oui</i> <i>yes</i></td><td><i>Nein</i> <i>non</i> <i>no</i></td></tr> </table>				<i>Ja</i> <i>Oui</i> <i>yes</i>	<i>Nein</i> <i>non</i> <i>no</i>								
<i>Ja</i> <i>Oui</i> <i>yes</i>	<i>Nein</i> <i>non</i> <i>no</i>												
<p>HORN Turbowirbeln® <i>HORN Turbo Tourbillonnage</i> <i>HORN Turbo Whirling®</i></p> <table border="1" style="width:100%; text-align: center;"> <tr><td><i>Ja</i> <i>Oui</i> <i>yes</i></td><td><i>Nein</i> <i>non</i> <i>no</i></td></tr> </table>				<i>Ja</i> <i>Oui</i> <i>yes</i>	<i>Nein</i> <i>non</i> <i>no</i>								
<i>Ja</i> <i>Oui</i> <i>yes</i>	<i>Nein</i> <i>non</i> <i>no</i>												
<p>Modulares System <i>Systeme Modulaire</i> <i>Modular System</i></p> <table border="1" style="width:100%; text-align: center;"> <tr><td><i>Ja</i> <i>Oui</i> <i>yes</i></td><td><i>Nein</i> <i>non</i> <i>no</i></td></tr> </table>				<i>Ja</i> <i>Oui</i> <i>yes</i>	<i>Nein</i> <i>non</i> <i>no</i>								
<i>Ja</i> <i>Oui</i> <i>yes</i>	<i>Nein</i> <i>non</i> <i>no</i>												
<p>JET-Wirbeln <i>JET Tourbillonnage</i> <i>JET Whirling</i></p> <table border="1" style="width:100%; text-align: center;"> <tr><td><i>Ja</i> <i>Oui</i> <i>yes</i></td><td><i>Nein</i> <i>non</i> <i>no</i></td></tr> </table>				<i>Ja</i> <i>Oui</i> <i>yes</i>	<i>Nein</i> <i>non</i> <i>no</i>								
<i>Ja</i> <i>Oui</i> <i>yes</i>	<i>Nein</i> <i>non</i> <i>no</i>												
<p>Standzeit aktuell <i>Durée de vie</i> <i>Tool life</i></p> <input style="width:100%;" type="text"/>													
<p>Aktuelles Werkzeug <i>Outil actuelle</i> <i>Current Tool</i></p> <input style="width:100%;" type="text"/>													
<p>Schnittdaten aktuell <i>Conditions de coupe actuelle</i> <i>Cutting speed actual</i></p>													
<p>Drehzahl Wirbelring <i>Vitesse tourbillonneur</i> <i>Rpm Cutter</i></p> <table border="1" style="width:100%; text-align: center;"> <tr><td><input style="width:50px;" type="text"/></td><td><i>1/min</i></td></tr> </table>				<input style="width:50px;" type="text"/>	<i>1/min</i>								
<input style="width:50px;" type="text"/>	<i>1/min</i>												
<p>Drehzahl Spindel <i>Vitesse broche</i> <i>Rpm Spindle</i></p> <table border="1" style="width:100%; text-align: center;"> <tr><td><input style="width:50px;" type="text"/></td><td><i>1/min</i></td></tr> </table>				<input style="width:50px;" type="text"/>	<i>1/min</i>								
<input style="width:50px;" type="text"/>	<i>1/min</i>												
<p>Programmierter C-Achsenvorschub in ° <i>Programmation axe C en°</i> <i>Feed C axe in °</i></p> <table border="1" style="width:100%; text-align: center;"> <tr><td><input style="width:50px;" type="text"/></td><td><i>°/min</i></td></tr> </table>				<input style="width:50px;" type="text"/>	<i>°/min</i>								
<input style="width:50px;" type="text"/>	<i>°/min</i>												
<p>Zielsetzung <i>Objectif</i> <i>Target</i></p>		<p>Skizze <i>Croquis</i> <i>Sketch</i></p>											

Datum _____ Name _____ Unterschrift _____

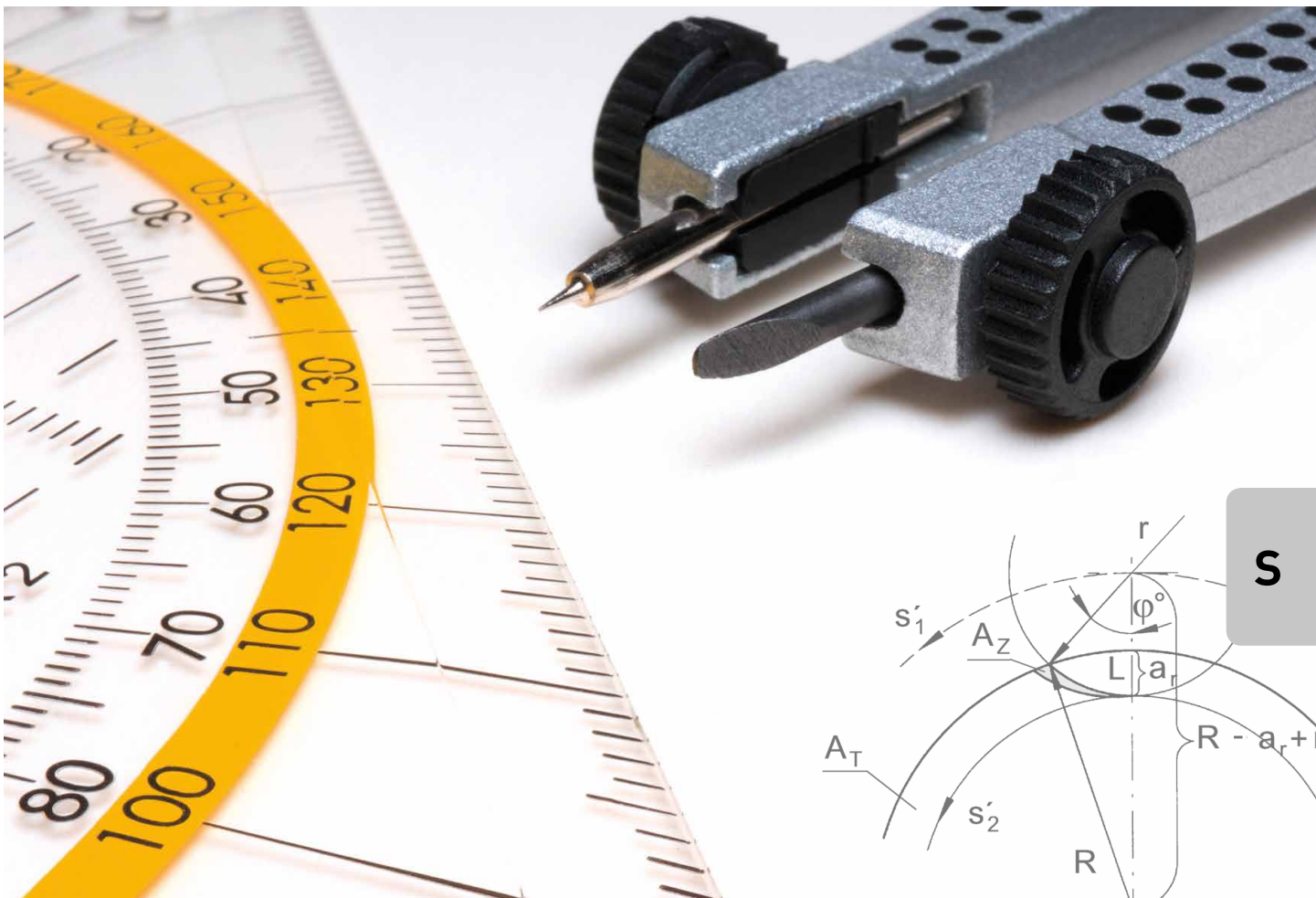

Inhalt/Summary

Seite/Page

Zubehör
Additional Equipment

646-650

**Eine Übersicht angetriebener Gewindewirbelwerkzeuge
finden Sie hier:**

An overview of driven thread whirling tools you can find here:

www.horn-group.com/de/service/technologieinformationen/Wirbelwerkzeuge



D 041 VL
0,4-1 Nm

Drehmoment-Schraubendreher mit Skala
- mit variabler Einstellmöglichkeit
- numerische Drehmoment-Anzeige in Fensterskala

Drehmoment stufenlos einstellbar mit Einstellwerkzeug Torque-Setter (enthalten).
Griff: Ergonomischer Mehrkomponentengriff, extrem handlich durch leichte und kompakte Bauweise. Klicksignal beim Erreichen des eingestellten Drehmomentwertes.

Normen: EN ISO 6798, BS EN 26789, ASME B107.14.M.

Genauigkeit: $\pm 6\%$, rückführbar auf nationale Normale



D 15 VL
1-5 Nm

Torque screw driver with scale
- variable torque setting
- adjusted torque is shown on display

The Torque can be adjusted with a special torque setter (included).

Handle: Ergonomical form gives perfect handling abilities. Audible signal when set torque is reached.

Standard: EN ISO 6798, BS EN 26789, ASME B 107.14.M.
Precision: $\pm 6\%$



D 28 VL
2-7 Nm

Einstellwerkzeug für Drehmoment-Schraubendreher

Griff: Celluloseacetat mit microfeiner Oberflächenstruktur

Klinge: Achtkantklinge, durchgehend gehärtet, verzinkt



ED 28 VL
für / for
D041VL / D15VL / D28VL

Device for setting the required torque

Handle: Celluloseacetat with micro structured surface

Blade: Octagonal (8 flats) blade, hardened galvanized



D515QL
5-14 Nm

Drehmoment-Schraubendreher mit Skala
- mit variabler Einstellmöglichkeit
- numerische Drehmoment-Anzeige in Fensterskala

Drehmoment stufenlos einstellbar mit Einstellwerkzeug Torque-Setter (enthalten).

Griff: Ergonomischer Mehrkomponentengriff, extrem handlich durch leichte und kompakte Bauweise. Klicksignal beim Erreichen des eingestellten Drehmomentwertes.

Normen: EN ISO 6798, BS EN 26789, ASME B107.14.M.

Genauigkeit: $\pm 6\%$, rückführbar auf nationale Normale

Torque screw driver with scale
- variable torque setting
- adjusted torque is shown on display

The Torque can be adjusted with a special torque setter (included).

Handle: Ergonomical form gives perfect handling abilities. Audible signal when set torque is reached.

Standard: EN ISO 6798, BS EN 26789, ASME B 107.14.M.

Precision: $\pm 6\%$



ED515QL
für / for
D515QL

Einstellwerkzeug für Drehmoment-Schraubendreher

Griff: Celluloseacetat mit microfeiner Oberflächenstruktur

Klinge: Achtkantklinge, durchgehend gehärtet, verzinkt

Device for setting the required torque.

Handle: Celluloseacetat with micro structured surface

Blade: Octogonal (8 flats) blade, hardened galvanized



DT6PK
DT7PK
DT8PK
DT9PK
DT10PK
DT15PK
DT20PK
DT25PK

für / for
D041VL / D15VL / D28VL



Plus

Wechselklinge für TORX PLUS® Schrauben

Klinge: Hochwertiger Chrom-Vanadium-Molybdän Stahl, durchgehend gehärtet, mattverchromt Wiha Chrom Top-Klingenspitze garantiert höchste Maßhaltigkeit. Farbcodierung dunkelgrün

Anwendung: Kontrolliertes Verschrauben bei vorgegebenem Drehmoment, in Kombination mit einem Wiha Drehmomentgriff.

Blade for TORX-Plus® screws

Blade: High quality Chrome-Vanadium steel, through hardened, chrome plated. Wiha Chrome Blade guarantees maximum precision. Colored code dark green

Utilization: Controlled screw setting with definite torque in combination with Wiha torque screw driver handle.

S



DT6K
DT8K
DT15K

für / for
D041VL / D15VL / D28VL



Wechselklinge für Torx Schrauben

Klinge: Hochwertiger Chrom-Vanadium-Molybdän Stahl, durchgehend gehärtet, mattverchromt Wiha Chrom Top-Klingenspitze garantiert höchste Maßhaltigkeit. Farbcodierung dunkelgrün

Anwendung: Kontrolliertes Verschrauben bei vorgegebenem Drehmoment, in Kombination mit einem Wiha Drehmomentgriff.

Blade for Torx screws

Blade: High quality Chrome-Vanadium steel, through hardened, chrome plated. Wiha Chrome Blade guarantees maximum precision. Colored code dark green

Utilization: Controlled screw setting with definite torque in combination with Wiha torque screw driver handle.



DT15PQ
DT20PQ
DT25PQ
DT27PQ
DT30PQ

für / for
D515QL



Plus

Wechselklinge für TORX PLUS® Schrauben

Klinge: Hochwertiger Chrom-Vanadium-Molybdän Stahl, durchgehend gehärtet, mattverchromt Wiha Chrom Top-Klingenspitze garantiert höchste Maßhaltigkeit. Farbcodierung dunkelgrün

Anwendung: Kontrolliertes Verschrauben bei vorgegebenem Drehmoment, in Kombination mit einem Wiha Drehmomentgriff.

Blade for TORX-Plus® screws

Blade: High quality Chrome-Vanadium steel, through hardened, chrome plated. Wiha Chrome Blade guarantees maximum precision. Colored code dark green

Utilization: Controlled screw setting with definite torque in combination with Wiha torque screw driver handle.



DSW15K
DSW20K
DSW25K
DSW30K
DSW40K

für / for
D041VL / D15VL / D28VL

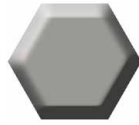

Wechselklinge für Innensechskant-Schrauben

Klinge: Hochwertiger Chrom-Vanadium-Molybdän Stahl, durchgehend gehärtet, mattverchromt. Wiha Chrom Top-Klingenspitze garantiert höchste Maßhaltigkeit. Farbcodierung rot

Anwendung: Kontrolliertes Verschrauben bei vorgegebenem Drehmoment, in Kombination mit einem Wiha Drehmomentgriff.

Blade for allen screws

Blade: High quality Chrome-Vanadium steel, through hardened, chrome plated. Wiha Chrome Blade guarantees maximum precision. Colored code red

Utilization: Controlled screw setting with definite torque in combination with Wiha torque screw driver handle



D14ZBK

für / for
D041VL / D15VL / D28VL

Universal-Bithalter für C6,3 und E6,3 (1/4") Bits

Klinge: Hochwertiger Chrom-Vanadium-Molybdän Stahl, durchgehend gehärtet, mattverchromt.

Hülse: Aus rostfreiem Stahl

Anwendung: Zum kontrollierten Verschrauben bei vorgegebenem Drehmoment, in Kombination mit einem Drehmomentgriff.

Universal Bitholder for C6,3 and E6,3 (1/4") Bits

Blade: High quality Chrome-Vanadium steel, through hardened, chrome plated.

Collar: Stainless steel

Utilization: For controlled screw setting with definite torque in combination with torque screw driver handle.



D14ZBQ

für / for
D515QL

Universal-Bithalter für C6,3 und E6,3 (1/4") Bits

Klinge: Hochwertiger Chrom-Vanadium-Molybdän Stahl, durchgehend gehärtet, mattverchromt.

Hülse: Aus rostfreiem Stahl

Anwendung: Zum kontrollierten Verschrauben bei vorgegebenem Drehmoment, in Kombination mit einem Drehmomentgriff.

Universal Bitholder for C6,3 and E6,3 (1/4") Bits

Blade: High quality Chrome-Vanadium steel, through hardened, chrome plated.

Collar: Stainless steel

Utilization: For controlled screw setting with definite torque in combination with torque screw driver handle.



14ZQK

Bithalter mit Quergriff für C6,3 und E6,3(1/4") Bits

Klinge: Hochwertiger Chrom-Vanadium-Molybdän Stahl, durchgehend gehärtet, mattverchromt

Hülse: Aus rostfreiem Stahl

Anwendung: Zum kontrollierten Öffnen

Universal Bitholder with T-handle for C6,3 and E6,3 (1/4") Bits

Blade: High quality Chrome-Vanadium steel, through hardened, chrome plated.

Collar: Stainless steel

Utilization: For controlled opening

S



- T6PW
- T7PW
- T8PW
- T9PW
- T10PW
- T15PW
- T20PW
- T25PW
- T30PW



Plus

Stiftschlüssel für TORX PLUS® Schrauben

Anwendung: Für alle TORX PLUS® Schraubaufgaben

Achtung: TORX PLUS®-Schlüssel passen NICHT in Torx-Schrauben

Wrench for TORX PLUS® Screws

Utilization: For all kind of using TORX PLUS® Screws

Attention: TORX PLUS®-Wrench does NOT fit for Torx-Screws



**FINDEN SIE JETZT IHRE
PASSENDE WERKZEUGLÖSUNG.**
FIND YOUR RIGHT
TOOLING SOLUTION NOW.

horn-group.com

DEUTSCHLAND, STAMMSITZ
GERMANY, HEADQUARTERS

—

Hartmetall-Werkzeugfabrik
Paul Horn GmbH
Horn-Straße 1
72072 Tübingen

Tel +49 7071 7004-0

Fax +49 7071 72893

info@de.horn-group.com

horn-group.com